

ISTANBUL TECHNICAL UNIVERSITY ★INSTITUTE OF SCIENCE AND TECHNOLOGY

**SELECTION OF PRECISE METHOD FOR SEEPAGE MEASUREMENTS
AND THE MOST SUITABLE MATERIAL FOR SEEPAGE CONTROL IN CANALS
(USING FUZZY LOGIC TECHNIQUE)**

**Ph.D Thesis by
MUHAMMAD RIAZ**

Department: Civil Engineering

Programme: Hydraulic Engineering and Water Resources

OCTOBER 2005

ACKNOWLEDGEMENTS

Praise to the **grace of Allah**, The Gracious, The Merciful. He bestowed man with intellectual power and understanding and gave him spiritual insight enabling him to discover his “Self” know his Creator through His wonders and conquer nature. Bow in obeiscene, I before my Lord, Who bestows me to fortitude and impetus to accomplish this task and elucidate a drop of already existing ocean of knowledge.

Next to all His Messenger **Hazrat Muhammad** (*Peace Be Upon Him*) Who is an eternal torch of guidance and knowledge for humanity.

It is indeed my honour and pleasure due to **Prof Dr. Zekai ŞEN**, Hydraulics Division Istanbul Technical University, Istanbul – Turkey, for providing me this opportunity to work with and all necessary guidance during this research study. His kind behavior coupled with friendly attitude towards science was a source of inspiration for me. The work presented in this manuscript was accomplished under his enthusiastic guidance, sympathetic attitude and intellectual supervision.

It seems impossible to pay thanks to my Kind and worthy co-supervisors Prof. Dr. Mehmet Ali TAŞDEMİR, Material Engineering Department, Istanbul Technical University, Prof. Dr. Ahmet DEMİR, Environmental Department, Yıldız Technical University, and also Prof Dr. Necati AĞIRALIOĞLU, head of Hydraulics Department whose kind behavior, keen interest and guidance, throughout the course of this study, helped me to do the task in time.

With profound gratitude and deep sense of devotion and obligation, I wish to especially recognize the help and encouragement of Dr. Mehmet Emin BİRPINAR, Associate Professor and Director, Environmental Department Istanbul region for his inspiring guidance and all that I learned from him during this research.

I highly appreciate the attention and contributions of Dr. Abdüsselam ALTUNKAYNAK and Mehmet ÖZGER, Research Assistants Istanbul Technical University whose brotherly attitude and selfless support pulled me through the

bumpy roads and also encourages me all the way during my research. Thanks for being a light.

I have no words of thanks for Institute of Science and Technology, Istanbul Technical University especially Director, Secretary and also the staff in student office for their kind guidance and also financing this research work.

I am thankful to Turkish Water Foundation for their continuous moral and financial support during my research study. I am also thankful to all staff working in water foundation Turkey for being so kind and friendly.

I wish to extend my thanks to my family especially my wife whose prayers, encouragement, moral and material support enabled me to reach over stairs of life smoothly and helped me to reach the destination.

Last but not the least, I am enormously grateful to all those who taught me even a single word of knowledge. I am greatly thankful to all Executives and field staff of FESS canal lining project especially Shahid Mehmood (Late) and Nasir Javad, Lab. Assistant Bahawalnagar Pakistan for their assistance during data collection and also Muhammad Saqib Shahzad, Ph.D student in İstanbul University for his assistance in compilation of this research work.

October 2005

Muhammad RIAZ

TABLE OF CONTENTS

ACKNOWLEDGEMENT	iii
ABBREVIATION	x
LIST OF TABLES	xi
LIST OF FIGURES	xiii
SYMBOLS	xvi
ABSTRACT	xvii
ÖZET	xix
1. INTRODUCTION	01
1.2 Project Area	03
1.3 Climate	06
1.4 Soils and Land Forks	06
1.5 Project Objectives	06
1.6 Objectives of Research	08
2. LITERATURE REVIEW AND BACKGROUND	09
2.1 Seepage Losses Studies	09
2.1.1 Seepage studies in Pakistan	09
2.1.2 Seepage studies outside Pakistan	12
3. METHODS OF SEEPAGE LOSS ESTIMATION IN IRRIGATION	
CANALS	16
3.1 Seepage Variables	18
3.2 Unit of Seepage Loss	20
3.3 Method of Seepage Loss Estimation	20
3.3.1 Analytical methods	20
3.3.2 Empirical methods	21
3.3.3 Physical methods	24
3.3.3.1 Ponding method	24
3.3.3.2 Inflow Outflow method	26
3.3.3.3 Seepage meters	27

3.3.3.4	Ground water evaluation analysis	28
3.3.3.5	In-place measurement of permeability	28
3.3.3.6	Laboratory permeability tests	30
3.3.3.7	Electronic logging	30
3.4	Overall Evaluation of the Seepage Methods	30
4.	SEEPAGE CONTROL MATERIALS	32
4.1	Geotextile	32
4.1.1	Geotextile Function.....	32
4.1.2	Installation	33
4.1.3	Growth rate of geotextile application	33
4.2	Geomembranes	34
4.2.1	History of geomembranes	34
4.2.2	Manufacture	36
4.2.3	Geomembrane application	37
4.3	FESS Canal Lining Project	39
4.4	Geomembrane Properties	42
4.5	Geomembrane Testing	43
4.6	Methodology	44
4.6.1	Physical properties	45
4.6.2	Mechanical properties	45
4.6.3	Laboratory tests on geomembranes	45
4.7	Source of materials	46
4.8	Laboratory test on Geotextile	49
4.9	Sample and Test Specimen Labeling System	50
4.10	Physical Test on Geosynthetics	51
4.10.1	Thickness test	51
4.10.2	Stiffness test	53
4.11	Mechanical Tests	55
4.11.1	Slow puncture tests	55
4.11.2	Graves tear test	60
4.11.3	Tensile strength test	61
4.11.4	Seams of geomembrane	62

5. CONSTRUCTION ASPECTS OF CANAL LINING	66
5.1 Design Consideration	66
5.1.1 Canal lining criteria	67
5.1.2 Design option for lining	67
5.1.3 Type of concrete	68
5.1.4 Joint sealants	68
5.1.5 Types of joint sealants	69
5.2 Geomembranes for linings.....	69
5.2.1 Seams and joints	70
5.3 Locations and Details of Experimental Linings	70
5.3.1 Design specification for experimental reaches	71
5.4 Fields Experiments on Canal Lining	72
5.4.1 Constructional aspects	72
5.4.2 Nature of the canals lined	72
5.4.3 Basic canal lining types.....	72
5.5 Results of Experiments.....	83
5.5.1 Aspects and criteria	83
5.5.2 Summary of experimental results	84
5.6 Relative Costs of Lining Types	84
5.6.1 Standard canal sizes	84
5.6.2 Relative cost for discharge up to 2.83 m ³ /sec (100 cfs)	85
5.6.3 Relative cost for discharge over 2.83 m ³ /sec (100 cfs)	87
5.6.4 Costs per unit area	88
5.6.5 Overall cost comparisons	89
5.7 Conclusions and Discussions	90
6. SEEPAGE INVESTIGATION AND DATA ANALYSIS	92
6.1 Plan of Seepage measurements	92
6.2 Pre Lining Seepage Measurements	92
6.3 Post Lining Seepage Measurements	93
6.4 Premised for estimation of Post Lining Seepage Losses	95
6.5 Comparison of seepage for Different Types of Lining under Experimental Component	95

6.5.1 Lining with hard cover Premised for estimation of Post Lining Seepage Losses	96
6.5.2 Lining with soil cover	99
6.6 Comparison of Seepage Using Different Measurement Techniques	100
6.6.1 Pre-lining seepage estimates from Ponding test	100
6.6.2 Pre-lining seepage estimates from Inflow Outflow test	100
6.6.3 Statistical analysis of seepage determination	102
6.6.4 Interpretive evaluation of seepage investigation	103
6.6.5 Hypothetical explanation of observed differences	105
6.6.6 Conclusive statement on seepage losses in the project area	106
6.7 Impact of Seepage Investigation on Future Projects.....	107
6.8 Seepage Data Analysis.....	108
6.8.1 Classical regression technique	108
6.8.2 Regression model assumptions	111
6.8.3 Fuzzy Logic technique applied for seepage analysis	111
7. SEEPAGE CONTROL MATERIALS	134
7.1 Results of testing of Geomembranes	134
7.2 Data Analysis Techniques	135
7.2.1 Classical regression technique	135
7.2.2 New analysis technique using grouping of data	147
7.2.3 Regression assumptions	152
7.2.4 Fuzzy Logic technique	156
8 CONCLUSIONS AND RECOMMENDATIONS	168
8.1 Seepage Investigations	168
8.1.1 Comparison of seepage methods	168
8.1.2 Construction aspects	168
8.1.3 Analysis Techniques	169
8.1.4 Recommendations regarding Seepage Evaluation	170
8.2 Geosynthetics	170
8.2.1 Laboratory Results	171
8.2.2 Basic Test for Analysis of Geomembrane	172
8.2.3 Analysis Technique	172

8.2.4 Recommendations.....	173
9. REFERENCES	174
APPENDIX.....	A-1 to A-36
CURRICULUM VITAE	A-37

ABBREVIATIONS

ASTM	:American Standard of Testing Materials
ARD	:Agriculture Rural Development
ASAE	:American Society of Agricultural Engineers
CCA	:Cultivated Command Area
CBC	:China Beijing Corporation
CSPE	:Chlorosulfonated Polyethylene
Disty	:Distributory
div	:canal diversion
EA	:Elastomeric alloy
EPDM	:Ethylene propylene dieter polymer
FESS	:Fordwah Eastern Sadiqia South
FML	:Flexible Membrane Liners
PP	:Flexible polypropylene
FPA	:Flexible Polyethylene Alloy
GCL	:Geosynthetics Clay Liners
IRI	:Irrigation Research Institute
LAQ-S_p	:Length Area Discharge and Seepage by results ponding method
LAQ-S_i	:Length Area Discharge and Seepage by results inflow outflow : method
LDPE	:Low Density Polyethylene
LLDPE	:Linear Low Density Polyethylene
HDPE	:High Density Polyethylene
MAF	:Million Acre Feet
MATLAB	:A Software of Math Laboratory
MDs	:Membership Degree
MFs	:Membership Functions
MHM	:Million Hetare Feet
NDP	:National Drainage Programme
NESPAK	:National Engineering Services Of Pakistan
NWFP	:North West Frontier Province
PVC	:Poly Venyle Chloride
SAR	:Staff Appraisal Report
SCARP	:Salinity Control and Reclamations Project
SURFER	:A Computer Software for Triple Diagrams
USBR	:United States Bureou Of Reclamation
USD	:United States Dollar
WAPDA	:Water and Power Development Authority

LIST OF TABLES

Table 2.1	Seepage values with respect to material type (Worstell, 1976)	13
Table 2.2	Seepage values with respect to material type (Deacon, 1984)	14
Table 2.3	Canal losses measurements for Periyer Vaigai Project Mudari, South India	14
Table 2.4	Seepage rate with to respect to nature of the channel (Singh, 1987)	15
Table 2.5	Typical seepage rate from unlined canals for different soil textures (Shahid, 1988)	15
Table 3.1	Values of constant C_s for different soil types	23
Table 4.1	Commonly used polymers and their approximate formulations	36
Table 4.2	Geomembranes in current use (Koerner, 1994)	42
Table 4.3	Tests performed on geomembrane (ASTM, 1995)	46
Table 4.4	Geomembrane materials tested	47
Table 4.5	Tests performed on geotextile (ASTM, 1995)	50
Table 4.6	Geotextile materials tested	50
Table 4.7	Different test perimeters using tension-compression machine	62
Table A.1	Specification and location of particular type of experimental lining	A-1
Table 5.1	Parabolic channels under experimental lining	71
Table 5.2	Seven basic types of experimental lining	75
Table 5.3	Variants of the experimental lining types	81
Table A.2	Summary of technical conclusions on lining types	A-3
Table A.3	Standard canal sized for cost comparison	A-5
Table A.4	Summary of relative costs of some lining types for canals carrying up to 2.83 m ³ /sec (100 cfs)	A-5
Table 5.4	Summary of relative cost of some lining types for canals carrying discharge over 8.49 m ³ /sec (300 cfs)	88
Table A.5	Summary of technical and cost comparison of lining types	A-7
Table A.6	Total water seepage for pre and post canal lining through ponding tests under production	A-8
Table 6.1	Pre and post-lining seepage rate of geomembrane with hard and soil cover under experiment component	96
Table A.7	Seepage comparison between different measuring techniques	A-9
Table 6.2	Ground water level and soil characteristics in the FESS project area	101
Table A.8	Statistical analysis of seepage using ponding and inflow-outflow measuring techniques	A-10
Table A.9	Prediction of additional water availability based on ponding and in-outflow tests	A.10
Table 6.3	List of logical propositions for prediciton of seepage from canal	119
Table 6.4	Logical rules for LAQ-Sp fuzzy model	124
Table A.10	Input and output data for the Fuzzy Model LAQ-Sp	A-11
Table 6.5	Logical rules for Fuzzy model LAQ-Si	129

Table A.11	Fuzzy results for Model LWAQ-Si	A-12
Table A.12	Summary of test results of geomembranes	A-13
Table A.13	Statistical parameters of geosynthetics testing variables	A-15
Table 7.1	Key to graph numbers for graphs comparing geomembrane test methods	136
Table A.14	Results Summary of geosynthetics materials by new grouping technique	A-16
Table 7.2	Logical rules for fuzzy model TRS-NFGH	161
Table 7.3	Fuzzy results showing observed input data, fuzzy triggered rules and observed and predicted output data for model TRS-NFGH	165
Table 8.1	Classification of materials with respect to stiffness	172

LIST OF FIGURES

Figure 1.1	Schematic diagrams of Indus basin, Irrigation network of Pakistan	04
Figure 1.2	FESS canal lining project area	05
Figure 3.1	Geometry and symbols for seepage conditions A, B and C	17
Figure 4.1	Digimatic Indication for measuring the thickness of geosynthetics	52
Figure 4.2	Apparatus for stiffness test on geomembrane	54
Figure 4.3	Universal Testing Machine (UTM) set for slow puncture tests	56
Figure 4.4	Hydrostatic puncture test for geomembrane	58
Figure 4.5	Dies used for cutting the sample for certain tests	60
Figure 4.6	Tensile compression machine for tensile and seam tests.	61
Figure 4.7	Pressurized dual seam technique (air pressure test)	64
Figure 5.1	Typical shapes of unlined canals in project area	73
Figure 5.2	Geomembrane on the bed and banks and protected by geotextile	74
Figure 5.3	Geomembrane on the bed only under soil cover with no geotextile	74
Figure 5.4	Geomembrane under mattress filled by concrete	76
Figure 5.5	Construction sequence for in-situ concrete over geomembrane	76
Figure 5.6	In-situ concrete over geomembrane	76
Figure 5.7	Precast concrete over geomembrane	77
Figure 5.8	Bricks in mortar over geomembrane	77
Figure 5.9	Vertical precast walls with insitu concrete in the bed both over geomembrane	77
Figure 5.10	Parabolic precast concrete units over geomembrane	78
Figure 5.11	Excavation of natural canals to give trapezoid shape.	78
Figure 5.12	Trimming of trapezoidal section to proper shape	79
Figure 5.13	Placing of geomembrane before lining	79
Figure 5.14	Placing of hard cover (in-situ concrete)	79
Figure 5.15	Finished form of lined concrete	80
Figure 5.16	Anchoring of geomembrane on the banks before placing of precast units	80
Figure 5.17	Placing of precast units in the canal section	80
Figure 6.1	Characteristics of the channels under production component	94
Figure 6.2	Pre and post-lining seepage from production component of the canals	94
Figure 6.3	Seepage from canals using geomembrane under hard covers	99
Figure 6.4	Seepage from canals using geomembrane under soil cover	99
Figure 6.5	Seepage measurement by different techniques	101
Figure 6.6	Water table level in FESS project Area	102
Figure 6.7	Graphical representation of Standard Deviation (mm/day)	104
Figure 6.8	Graphical representation of Co-efficient of Variation (%)	104

Figure 6.9	Series histograms of seepage variables	108
Figure 6.10	Scatter diagrams between different variables	109
Figure 6.11	Schamatic Diagram of Fuzzy Components (Şen, 2004)	113
Figure 6.12	'Low' fuzzy member and triggers	114
Figure 6.13	The fuzzy 'high' membership function	115
Figure 6.14	Two overlapping fuzzy sets and firing	115
Figure 6.15	Fuzzy input data	116
Figure 6.16	Fuzzy result from the two rules	120
Figure 6.17	Defuzzification of max-min composition	121
Figure 6.18	Weighted fuzzy defuzzification calculations	123
Figure 6.19	Membership functions for LAQ-Sp input variables	126
Figure 6.20	Membership function for model LAQ-Sp output variables	126
Figure 6.21	Graph between observed and predicted values a) Trial #1, b) Trial #2 and c) Trial # 3)	128
Figure 6.22	Fuzzy membership fuctions for model LAQ-Si input variables	131
Figure 6.23	Fuzzy membership fuctions for model LAQ-Si output variables	131
Figure 6.24	Observed and Predicted Seepage (In-Outflow) for Model LAQ-Si for a) Trail 1, b) Trial 2 and c) Trial 3	132
Figure 7.1	Behaviour of different materials under tensile strength test (Direct testing machine output)	137
Figure 7.2	Behaviour of different materials under tapered probe slow puncture test (Direct testing machine output)	140
Figure 7.3	Behaviour of different materials under 8 mm probe slow puncture test (Direct testing machine output)	140
Figure 7.4	Behaviour of different materials under pyramid over water (Direct testing machine output)	142
Figure 7.5	Behaviour of different materials under pyramid over aluminium(Direct testing machine output)	144
Figure 7.6	Graph between thickness and stiffness/fexibility	149
Figure 7.7	Non-linearity	153
Figure 7.8	Logarithmic transformations	154
Figure 7.9	Non-normality of the residual terms	154
Figure 7.10	Variable variance	155
Figure 7.11	Rainfall elevation relationship	155
Figure 7.12	Relationship between the increments	156
Figure 7.13	Series histrograms of different geomembrane testing variables	158
Figure A.42	Triple diagrams between different variables with the slow puncture test (B) as dependent variable	A-35
Figure 7.14	Input Fuzzy MFs for Fuzzy Model TRS-NFGH	162
Figure 7.15	Output fuzzy MFs for Fuzzy Model TRS-NFGH	164
Figure 7.16	Graph between observed and predicted values	166
Figure A.1	Graph between thickness and stiffness/fexibility	A-19
Figure A.2	Graph between thickness and tapered probe	A-19
Figure A.3	Graph between thickness and 8 mm probe	A-19
Figure A.4	Graph between thickness and pyramid over water	A-20
Figure A.5	Graph between thickness and pyramid over aluminium	A-20
Figure A.6	Graph between thickness and critical cone height	A-20
Figure A.7	Graph between thickness and tensile strength	A-21
Figure A.8	Graph between thickness and tear strength	A-21
Figure A.9	Graph between relative stiffness (RS) and Tapered Probe (A)	A-22

Figure A.10	Graph between relative stiffness (RS) and Tapered Probe (B)	A-22
Figure A.11	Graph between relative stiffness (RS) and Tapered Probe (B)	A-23
Figure A.12	Graph between relative stiffness (RS) and Tapered Probe (B)	A-23
Figure A.13	Graph between relative stiffness (RS) and Tapered Probe (B)	A-24
Figure A.14	Graph between relative stiffness (RS) and Tapered Probe (B)	A-24
Figure A.15	Graph between relative stiffness (RS) and Tapered Probe (B)	A-25
Figure A.16	Graph between Tapered Probe and 8 mm Probe	A-26
Figure A.17	Graph between tapered probe and pyramid over water	A-26
Figure A.18	Graph Between tapered probe and pyramid over aluminium	A-26
Figure A.19	Graph between tapered probe and critical cone height	A-27
Figure A.20	Graph between tapered probe and tensile strength	A-27
Figure A.21	Graph between tapered probe and graves tear tests	A-27
Figure A.22	Graph between 8 mm probe and pyramid over water	A-28
Figure A.23	Graph between 8 mm probe and pyramid over aluminium	A-28
Figure A.24	Graph between 8 mm probe and critical cone height	A-28
Figure A.25	Graph between 8 mm probe and tensile strength	A-29
Figure A.26	Graph between 8 mm probe and tear strength	A-29
Figure A.27	Graph between pyramid over water and pyramid over aluminium	A-29
Figure A.28	Graph between pyramid over water and critical cone height	A-30
Figure A.29	Graph between pyramid over water and tensile strength	A-30
Figure A.30	Graph between pyramid over water and tear strength	A-30
Figure A.31	Graph between pyramid over aluminium and critical cone height	A-31
Figure A.32	Graph between pyramid over aluminium and tensile strength	A-31
Figure A.33	Graph between pyramid over aluminium and tear strength	A-31
Figure A.34	Graph between critical cone height and tensile strength	A-32
Figure A.35	Graph between critical cone height and tear strength	A-32
Figure A.36	Graph between tensile strength and tear strength	A-32
Figure A.37	Graph between tensile strength and seam shear strength	A-33
Figure A.38	Graph between tensile strength and seam peeling strength	A-33
Figure A.39	Graph between 8 mm probe and seam shear strength	A-33
Figure A.40	Graph between 8 mm probe and seam peeling strength	A-34
Figure A.41	Graph between seam shear strength and seam peeling strength	A-34

SYMBOLS

°C	:Degree centigrade
%	:Percentage
A	:Area of canal
A)	:Slow puncture test (8 mm probe)
B	:Slow puncture test (Tapered probe)
B/D	:Bed depth ration
C	:Pyramid puncture test (Over water)
cms	:Cubic meter per second
cusec	:Cubic feet per second
D	:Pyramid puncture test (Over Aluminum)
D_p	:Depth of bed from permeable /impermeable layer
D_w	:Depth of water
D_b	:Depth of bed of canal
F	:Tensile Strength Test
F-d	:Force displacement
ft	:feet
G	:Seam Shear Strength Test
H	:Seamed Peeling Strength Test
H_w	:Head of water
ha	:Hectare
I-O	:Inflow outflow
K	:Flexibility / Stiffness
L	:Length of canal
N	:Critical Cone Height
N	:Manning`s Coefficient
Q	:Discharge of canal
RS	:Relative Stiffness
Rsi	:Relative Error between predicted and observed values in Inflow outflow method
Rsp	:Relative Error between predicted and observed values in ponding method
S_i	:Seepage measurement by inflow outflow method
Si(ob)	:Observed Seepage by Inflow outflow method
Si(pr)	:Predicted Seepage by Inflow outflow method
S_p	:Seepage measurement by ponding method
Sp(ob)	:Observed Seepage by Ponding method
Sp(pr)	:Predicted Seepage by Ponding method
T	:Thickness
Wa	:Top width of canal
W/T	:Water Table

**SELECTION OF PRECISE METHOD FOR SEEPAGE MEASUREMENTS
AND THE MOST SUITABLE MATERIAL FOR SEEPAGE CONTROL IN CANALS
(USING FUZZY LOGIC TECHNIQUE)**

ABSTRACT

Seepage and operational losses from the distribution systems are causing problems for the designers, managers of irrigation districts and for water users. The designer must provide sufficient capacity in the canals to supplement for these losses, and the managers must divert extra water into parts of the system to assure ample flow to the lower reaches/tails of all laterals. The water users must be provided with ample storage to offset seepage losses. The managers also have to deal with complex legal and technical problems that arise if seepage losses cause high water table in fields adjacent to the canal.

So far, conventional materials like cement concrete, bricks and tiles have been used for lining of canals to minimize the seepage losses. Now plastic film is one of the many materials developed for use as flexible membrane for lining canals, catchment area and reservoirs. Asphalt, because of its waterproofing properties, and low cost has also been prominent among materials investigated for water harvesting and seepage control. Now a days, a variety of different plastic materials are available in the form of PVC, LDPE, LLDPE, FPA and HDPE from unreinforced to reinforced ones. These different materials have been used for experimental investigation in order to view their physical, mechanical and biological properties. Some insitu experiments have also been conducted on these geomembranes under different field conditions in order to analyse the seepage control effectiveness. A technical and cost comparison has been made in order to select the most suitable material for seepage control.

The evolved strategies would be utilized in deciding the precise seepage measurement method and accurate usage of effective material for its control. The research study is conducted in such a manner that it can be easily adopted for any site with similar problems. This research study addressed the multidimensional problem

of Indus Basin, and can be utilized to any basin where there is problem of water logging and salinity.

**SIZMA ÖLÇÜMLERİ VE EN UYGUN KANAL KAPLAMA MALZEMESİ
İÇİN HASSAS YÖNTEM SEÇİMİ
(BULANIK MANTIK TEKNİĞİNDEN YARALANARAK)**

ÖZET

Dağıtım sistemlerindeki sızma ve kayıplar; tasarımcılar, bölge sulama yöneticileri ve su kullanıcıları için problemlere neden olur. Tasarımcı, kanallardaki bu kayıpları en alt seviyeye çekerek yeterli kapasiteyi sağlamalıdır. Yöneticiler, sisteme yandan gelen veya aşağı kısımda bulunan kanalları da göz önünde bulundurarak gereğinden fazla su göndermemelidir. Ayrıca sızma kayıpları gibi hukuki ve teknik problemler de göz önünde bulundurulmalıdır. Bu kayıpların sebepleri, sayısal modellerde farklı akifer alt sınır koşulları incelenmiştir. Bu çalışma, akıntılı ve akıntısız kanallardaki ölçüm için farklı bir metodun geliştirilmesine yardımcı olmuştur. En son test tekniklerinden bazıları tartışılmıştır. Bu farklı testlerin karşılaştırılması için bulanık mantık yöntemi kullanılmış ve sızıntının gelişimi için en uygun ve kesin test seçilmiştir.

Çimento, kiremit gibi klasik malzemeler kanallardaki sızıntı kayıplarını en alt seviyede tutmak için kullanılır. Kanal kaplamaları, havzalar ve biriktirme havzaları için esnek membran olarak geliştirilmiş malzemelerden birisi de plastik filmlerdir. Su geçirmemesi ve maliyetin düşük olması nedeniyle asfalt, sızma kontrolü için kullanılan önemli bir malzemedir. Bugünlerde PVC, LDPE, LLDPE, FPA ve HDPE gibi bir çok farklı türde plastik malzemeler kullanılmaktadır. Bu tür malzemeler, fiziksel, mekanik ve biyolojik özelliklerini belirlemek amacıyla çeşitli deneyler ile test edilmektedir. Sızma kontrolü için geomembranlar üzerinde değişik koşullar altında sızma deneyleri yapılmıştır. Sızma kontrolü için en uygun malzemenin seçilmesi için diğer türlerle karşılaştırmaları yapılmıştır.

Sızma kontrolü için, malzemenin uygun kullanımı ve uygun sızma ölçüm yöntemleri hakkındaki karar, bu deneylere bakılarak verilmiştir. Bu araştırma

benzer problemler için kolayca uygulanabilir. Çalışmada İndus havzasındaki çok boyutlu problem incelenmiş ve bu çalışma tuzluluk problemlerine sahip havzalarda rahatlıkla uygulanabilecektir.

1. INTRODUCTION

Seepage and operational losses from the distribution systems are causing problems for the designers, managers of irrigation districts and for water users. The designer must provide sufficient capacity in the canals to supplement for these losses, and the managers must divert extra water into parts of the system to assure ample flow to the lower reaches/tails of all laterals. In other words, the water users must be provided with ample storage to offset seepage losses. The managers also have to deal with complex legal and technical problems that arise if seepage losses cause high water table in fields adjacent to the canal (Worstell, 1976).

Colossal water losses take place from several thousands kilometer length of unlined irrigation channels traversing alluvial plains of the Indus basin irrigation system. These losses constitute a substantial percentage of total utilizable water and lead to waterlogging and salinization of adjacent areas causing gross environmental degradation. It has been estimated that out of total surface withdrawals of 13 MHM (Million hectare meter) (106 MAF (Million acre feet)) carried in country's irrigation network, transit losses in the alluvial canals and distributaries are 2.5 MHM (21 MAF) whereas 2.0 MHM (16 MAF) water is lost through watercourses and farm ditches. The groundwater is saline in the Indus basin; seepage from irrigation channels becomes a net loss and aggravates the drainage need of the area.

Seepage control is primal function perceived from most canal lining. Although structural safety, increased conveyance capacities, erosion protection or reduced maintenance may in special cases substitute need to line the irrigation canals yet lining has been considered as effective measure for mitigation the waterlogging and salinity problem besides conservation of surface water. Seepage from channels is a dynamic process that is complicated by a variety of factors including non-uniformity of soil, water quality, sedimentation, erosion, soil permeability, fluctuating water tables and water levels in the canals and also periodic filling and drying up of the canals.

The reason for these losses is investigated by performing numerical model solutions for a series of example with different conditions at the lower boundary of the aquifer (Wachyan and Ruston, 1980). These do not give the real losses as the methods do not take care of evaporation and conveyance losses. However, field tests will give the true picture of the losses if these are measured to a certain precision and to the prevalent field conditions. A reliable estimation of seepage loss quantities from canals becomes crucially important while evaluating performance of an irrigation channel and drainage scheme. Various methods have been cited in literature to study seepage from irrigation channels (Weller and McAter, 1993).

The research in this thesis will help in evaluating the different methods for seepage measurements from canals under flowing and non-flowing conditions. Some other latest test techniques will also be discussed and will be compared with different tests using some traditional and fuzzy logic techniques, and the most suitable and precise test will be selected for seepage evaluation.

Many conventional materials like cement concrete, bricks and tiles have been used for lining of canals to minimize the seepage losses. Now plastic film is one of the many materials developed for use as flexible membrane for lining canals catchments area and reservoirs. Asphalt, because of its waterproofing properties, and low cost has also been prominent among materials investigated for water harvesting and seepage control (Renold et al, 1976). Now a days, a variety of different plastic materials are available in the form of PVC, LDPE, LLDPE, FPA and HDPE from un-reinforced to reinforced ones. These different materials need experimental investigation in order to view their physical, mechanical and biological properties. Some in situ experiments must also be done on these geomembranes under different field conditions in order to analyze the seepage control effectiveness. A comparison will be done in order to select the most suitable material for seepage control.

The Fordwah Eastern Sadiqia South (FESS) project area was reclaimed during 1930`s when surface irrigation water was first delivered to Bahawalnagar area (A city in the Southern Eastern part of Pakistan). Initially the groundwater tables were well below the ground level, however, seepage from unlined irrigation channels, inefficient use of irrigation water and deficient drainage gradually resulted in excessive groundwater table causing water logging and salinization. According to the base line survey carried in 1989, water distribution to distributaries and minors was

inequitable. Flows in the watercourses were also inequitable drawing with some less discharge than the design discharge while others draw considerably in excess of design discharge. The World Bank funded FESS project is a part of an overall integrated programme within national water sector and include installation of canal lining as one of the envisaged water conservation measures (World Bank, 1992).

The lining in the project involved, (1) The production lining, namely lining of channels with design discharge up to 2.83 cms (100cfs), (2) The experimental lining namely to conduct research on several lining systems for their efficiency as to seepage control, improvement in lining performance and structural durability. The research involves performance and evaluation of various new and conventional canal lining materials and types. Seepage investigations on these test lining channels are aimed to provide guidelines for future research work.

The evolved strategies will be utilized in deciding the precise seepage measurement method and accurate usage of effective material for its control. The research study will be conducted in such a manner that it can be easily adopted for any site with similar problems. This research study will address to the multidimensional problem of Indus Basin, and may be utilized to any basin where there is problem of water logging and salinity.

1.2 Project Area

Fordwah Eastern Sadiqia South (FESS) Irrigation and Drainage project, located in the South Eastern part of the Punjab province of Pakistan, is a part of an overall integrated programme within national water sector where installation of canal lining is envisaged as a major water conservation measure (Figure 1.1). The project, covering gross area of about 121,000 ha and canal command area (CCA) of about 105,000 ha is largely underlain with saline groundwater. Water tables in the area were at 20 m depth below the ground surface before advent of Irrigation system over the area in the early thirties. Irrigation inflows to the project area are controlled by Sulemanki headworks, completed in 1933, on the Satluj River. Water is diverted from the left bank of the Sulemanki headworks to the Eastern Sadiqia canal that runs for a distance of 74 km before reaching into Hakra and Malik Branch canals these are the upper end of the FESS Project. The irrigation induced recharge coupled with inadequate drainage facilities is considered to have continuously added to water table

buildup resulting in wide scale water logging and salinization in the area. Detailed descriptions of the FESS Project area are presented in Figure 1.2.

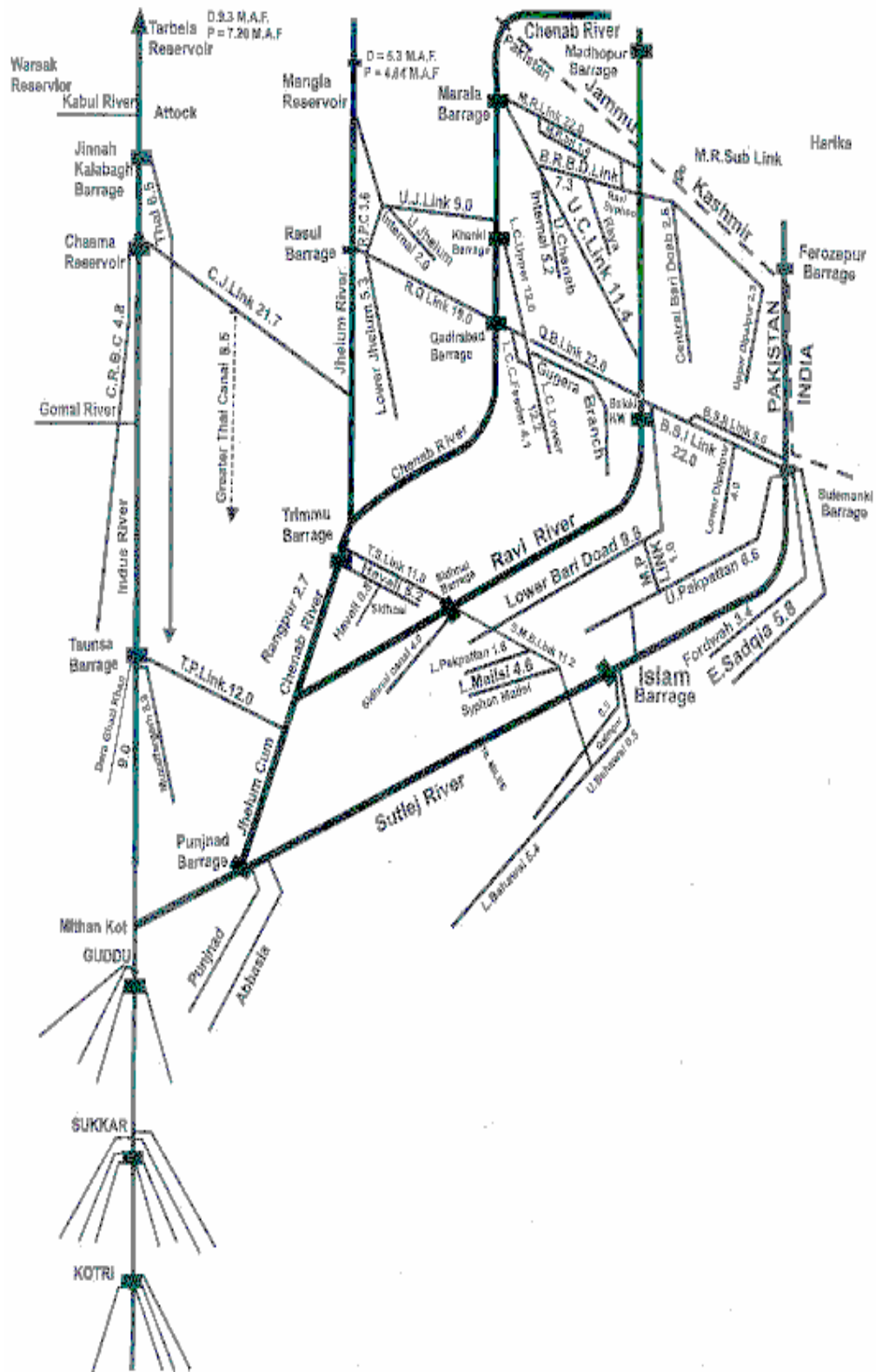

Figure 1.1 Schematic diagrams of Indus Basin, irrigation network of Pakistan

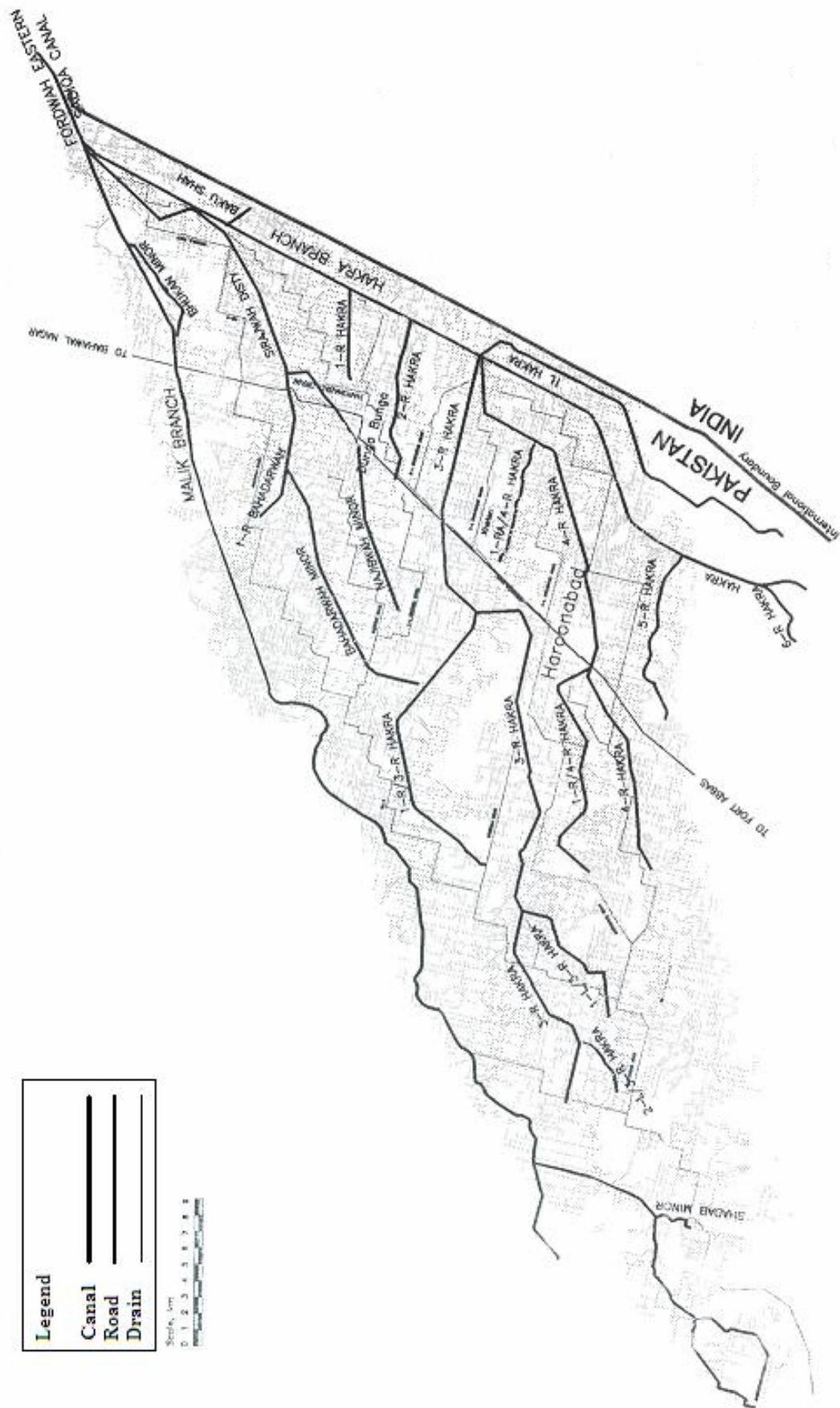

Figure 1.2 FESS (Fordwah Eastern Sadiqia South) canal lining project area

The appraisal report issued for the project by World Bank perceives that proposed lining works under this project will control excessive seepage resulting in severe waterlogging and salinity in the area besides removing severe water supply constraints by increasing delivery efficiency and equity of water distribution

1.3 Climate

The climate of the area is typical of the low-lying interior of the Indo-Pak Sub-continent and is characterized by large seasonal fluctuations in temperature and rainfall. The hottest month is June when average maximum temperature over a period of fifteen years has been recorded as 46 °C . The temperature frequently exceeds 49 °C. January is the coldest month, when the mean maximum and minimum temperature being 24 °C and 0 °C respectively. The area experiences an arid climate in the dry season (59 mm/yr) except during the June - September monsoon season (134 mm/yr). The weighted average depth of precipitation over the area on annual basis amounts to 193 mm (Hassan et al., 1995)

1.4 Soils and Land Forks

The project area was claimed from the Cholistan desert in the 1930s when surface irrigation water was first delivered to that part of Punjab. The topsoil is generally medium textured and is underlain by several hundred metres of sand and silts. The topography is largely flat with no natural drainage. Outcropping sand dunes occupy about 6 percent of the area. Almost 70 percent of the area is made up of terrace remnants. The most important pedological feature of these soils is the occurrence of compact and calcareous silty/clayey non-continuous layers at varying depths, which restrict the downward flow of water and act as barriers to vertical drainage.

1.5 Project Objective

The Fordwah Eastern Sadiqia (South), Irrigation and Drainage project was planed in 1992 within the overall objective of the water sector to develop land and water resources so as to increase agricultural production and to achieve self sufficiency in food and fiber production. In the project area the optimum agricultural development is hindered by water logging and salinity and the overall objective of the project is to ameliorate the problem by the provision of canal lining, interceptor drains, on-farm

water management and surface drainage facilities together with field trials for sub-surface drainage. Information provided in the NESPAK (1991) feasibility reports was used during the preparation of the Staff Appraisal Report (SAR) by the World Bank to estimate that as a result of increased capacity and improved control project implementation could result is an additional 11,230 hectare-m (91,000 acre-ft) of water to be available at the root zone within the project area. The volume of seepage water which may be saved by the canal lining component has yet to be evaluated, the results of ponding tests carried out during the closure periods, and inflow-outflow tests provide some initial indication of the expected benefits of seepage control with canal lining.

With the increased availability of water, cropping intensity in the area is expected to increase from the estimated present 133 % to approximately 159 %, with further benefits also from increased yields.

The overall project is designed to remove severe water supply constraints by improving the delivery efficiency of canals and watercourses and at the same time reducing seepage to the groundwater. It is intended that improved control through lining of distributaries and minors resulting in more equitable distribution of water would bring efficient water use within watercourse commands. The objectives of the project are to:

- 1 Raise agricultural production, employment and income,
- 2 Reduce the recharge to the groundwater table, thereby reducing the need for expensive sub-surface drainage and environmentally harmful effects related with such drainage;
- 3 Increase equity of water distribution among users,
- 4 Increasing water supply to reduce the gap between crop water demand and irrigation supply, improving water management, and draining excess storm water,
- 5 Slowing down land deterioration due to water logging and salinity through reduction of seepage losses from irrigation channels and improvement of on-farm water management, and
- 6 Improving availability of agricultural inputs and services.

The last five objectives can only be completed through research work and were completed in research phase of the project.

1.6 Objective of Research

- a) To collect and analyse the seepage losses data from various agencies engaged in irrigation, water resources and water conservation studies,
- b) To compare and evaluate the various seepage model's equations being used for estimation of seepage losses,
- c) To recommend the most precise procedure for measurements and estimation of seepage losses,
- d) To investigate relevant tests that show performance of seepage control materials (Geomembrane materials) in canal lining,
- e) To conduct tests that will assist in the drawing up of better material specifications,
- f) To compare different kinds of seepage control materials (Geomembrane materials) potentially suitable for canal lining using different techniques with different covering materials using variable cover depth,
- g) To investigate the canal section that is not equally good with respect to its hydraulic efficiency, but also suitable for economic construction, and finally, and
- h) To perform hydraulic monitoring and evaluation of irrigation channels for FESS project (Fordwah Eastern Sadiqia South Irrigation and Drainage Project) after insitu application of different seepage control materials.

2. LITERATURE REVIEW AND BACKGROUND

Brief survey of the past work done on the seepage and the related work reference will be helpful in developing the present work. Following are the reports related to seepage estimation completed within and outside of Pakistan using different techniques.

The loss of irrigation water in channels, distributaries, minors and watercourses in Pakistan is a continuous problem. The lining of canals is said to be the only solution to control seepage losses and consequently to increase conveyance efficiency. Many gigantic canal lining projects have been launched in the country to improve the delivery system efficiency. However, the huge investments on lining must be justified by the volume of the water saved. For this purpose, a lot of engineers, scientists and technologists have done research work on seepage losses from lined / unlined irrigation system.

2.1 Seepage Losses Studies

Many seepage studies have been performed in Pakistan and elsewhere. However, an analysis of seepage studies in Pakistan shows that the researchers have often used different methodologies to estimate the seepage losses in Indus basin. It is difficult to compare the results of these studies because each time the objectives of the studies were different. The main objective in these studies were to assess the actual performance of the canal system, effectiveness of the lining or to identify the canal reaches prone the excessive seepage.

2.1.1 Seepage analysis in Pakistan

- i) Chrales (1963) reported that seepage losses from unlined canals in Pakistan, are normally assumed as 0.23 m per day or 8 cfs/msf (cusec per million square feet) of the wetted area (0.7 cubic feet per square feet per day). The analysis of the data indicated that the seepage losses in some of the canals

- ii) may be as high as 0.92 m/day (35 cfs/msf) or 4 times as high as the normal rate.
- iii) Patten et al. (1963) analysed that the data of the seepage losses of 70 representative canal reaches in order to develop a general formula for estimating seepage on the basis of discharge. The losses were measured for different soil types and under water table conditions in the Punjab, Pakistan. Three types of equations were developed for three plains of the Punjab, Pakistan. (Rechna, Chaj and Thal doabs). The inflow-outflow method was used for seepage loss measurement. The analysis indicated that an approximate relationship exists between seepage loss rate and channel discharge in the irrigation system of the Punjab. It should, however, be noted that the nature of such relationship is inherently approximate owing to variable correlations between hydraulic gradient or wetted area and discharge and a single precise relationship between discharge and gradient. For example, it could hardly be expected to exist in two areas different regional water table depths. Also, according to Patten et al. (1963) empirical relationship between seepage loss per canal mile and discharge for Rechna and Chaj doabs as derived under the prevailing hydrological conditions showed,

$$S = 0.03 Q^{0.71} \quad (2.1)$$

where S=Seepage loss per canal mile (cfs /mile), and Q=Canal discharge (cfs).

- iv) Ahmed (1974) reviewed a large number of measurements of canals losses in the Indus Basin. He quoted seepage results ranging from 0.06 to 1.25 m/day (0.19 to 4.1 ft/day). According to him seepage losses are dependent upon the hydraulic conductivity of the aquifer, but not on the water table position within the aquifer.
- v) Ahmed (1982) from studies on canal seepage in Lower Indus Project found that average seepage loss was about 0.12 m/day.
- vi) O`Mara (1986) suggested that the actual canal losses are about four times the value adopted during initial planning of the water control projects in the Indus Basin.

- vii) Goldsmith and Makin (1989) stated that conveyence losses in the 15 km tail reach of the lined Mudki distributary as 0.30 m/day. Measurements reported by Pual and Dhillon (1989) gave loss rates for the four months old Sunam sub-branch lining had a low seepage rate of 0.058 m/day, whilest, the six years old Mukstar distributary was loosing 0.50 m/day.
- viii) Chohan (1989) provided estimates of the average losses up to the turnout point (outlet) from irrigation canals in Pakistan as 20 to 25 % of inflow at the head of the main canal.
- ix) For the Fourth Drainage Project (USBR, 1989) estimated losses are based on the size of the canal and the wetted perimeter. They obtained the seepage losses to be around 9 % of the total discharge of the canals.
- x) The Technical Assistant Team of Agricultural and Rural Development (ARD), USAID monitored the four lined canal system in Punjab, under the Command Water Management project (Haider et al., 1989). Seepage losses were measured using the Inflow-Outflow method for the selected reaches of Shahkot distributary, Pakpattan canal system distributaries and 6/R Hakra system. Average seepage rates for Naiz Beg Distributary, Shahkot distributary, Pakpattan canal system and 6/R Hakra systems were found to be 0.21, 0.026, 0.14 and 0.16 m/day.
- xi) Bhutta (1990) measured seepage losses for Lagar distributary (unlined), which off takes from Upper Gugera Branch of Lower Chenab Canal System (LCC) using the inflow-outflow method. Lagar distributary was running at its design discharge of 1 cumec (38 cusec). Total loss observed was 12 % of the canal discharge of 1 cumec (38 cusec). The conversion of this value based on wetted area amounts to 0.15 m/day.
- xii) National Engineering Services of Pakistan (NESPAK, 1991) used as USBR formula, for determining the seepage loss for canals with discharge greater than 2.8 m³/sec. The following relationships were used,

$$q_1 = K_1(B + 2d)/3.5 \quad (2.2)$$

and

$$q_2 = q_1(B - 2d)/(B + 2d) \quad (2.3)$$

where q_1 = seepage (ft³/ft²-day) when the water table is below the canal bottom (free drainage condition), K_1 = Hydraulic conductivity adjacent to the

canal section (ft/day), D = depth of water in the canal at the normal operating level (ft), B = width of the water surface in canal at normal operating level (ft), 3.5 = A factor used for adjusting the hydraulic conductivity test values to seepage losses from the ponding tests, and q_2 = Terminal seepage rate after water table mound rises above the bottom of the canal (ft/ft-day).

- xiii) Johns and Remco (1990) studied the performance of Fordwah Branch Canal (unlined) for the period October 1990 to March 1991. They prepared a water balance of the canal over a period of ten daily basis and calculated the efficiency of the canal. The inflow-outflow method was used for seepage measurements, which gave an average seepage loss of 0.575 m/day.
- xiv) Zaighum et al. (1992) measured seepage loss in the Lower Gugera Branch Canal using the inflow outflow method. The field measurements were taken during 1991-92 and the results indicated a seepage loss rate of 0.3 m/day.
- xv) Bhutta et al. (1992) measured seepage losses in Lower Gugera Branch Canal using inflow-outflow method. The field measurements were taken between 1991 and 1992 and the results indicated a seepage loss rate of 0.3 m/day (0.984 ft/day).
- xvi) Cheheena and Piracha (1993) measured seepage losses of the Chabba distributary (unlined) of Northern Branch of Lower Jehlum Canal by inflow outflow method. The seepage loss rate was estimated as 0.09 cms (3.4 cfs) where 20 % at the design inflow of 0.48 cms (17 cfs). This amounts to 0.3m/day.

2.1.2 Seepage study outside Pakistan

- i) Kennedy (1895) was the first to report, quantitatively, the seepage losses in irrigation system in the subcontinent. He stated that 47 % of the total water supplied is lost before it reaches the farms. Kennedy estimated seepage losses from main canals to be at the order of 0.26 m/day.
- ii) USBR (1954), quoted by Kraatz (1977) reported that 37 % of all water diverted on 46 of its projects was lost in conveyance. Twenty three percent was attributed to seepage and 14 % to operational waste. The seepage loss measurements were conducted on lined canals at three locations viz: Farewell Main canal, Franklin canal and Upper Meeker canal Nebraska, USA, (OCCS,

1986). Ponding tests were conducted to measure the seepage loss before and after the lining of the canals. Seepage rates before lining were 0.17, 0.30, and 0.34 m/day (0.56, 1.01 and 1.13 ft/day) respectively for these canals. After lining, the seepage rates were 0.08, 0.14 and 0.17 m/day (0.27, 0.45 and 0.56 ft/day) for the same canals.

- iii) Ahuja and Mehndiratta (1967) reported 18 to 50 % of water losses in irrigation canals in India, whilst SARAN et al. (1967) stated losses of around 47 % in irrigation canals in India, 33 to 60 % in USA and 25 to 60 % Mexico.
- iv) Worstell (1976) reviewed the losses from canals in Idaho, USA and suggested the typical losses depending upon the nature of the soil as,

Table 2.1 Seepage values with respect to material type

Material type	Seepage rate (mm/day)
Medium clay loam	150 to 450
Pervious soils	450 to 600
Gravels	750 to 1000

He also presented important information on seepage losses from lined canals, which have weathered and aged for several years as 0.7 m/day on average.

- v) Pontin et al. (1979) measured the direct losses using seepage meters in Ismailia canal, Egypt. He suggested that the seepage losses using seepage meters ranged from 0.6 to 2.4 m/day, whilst, results from flow gauging indicated losses in the range of 0.15 to 1.52 m/day.
- vi) Murthy (1980) reported the seepage losses from lined irrigation channels in Indian Punjab as 6 % of the total discharge. Conversely, the losses reported for unlined canals were 40% of the total discharge.
- vii) Rajan (1980) summarised seepage losses in lined and unlined canals in India. He stated that seepage loss for unlined ranges from 0.15 to 0.57 m/day. He further reported that seepage loss for lined canals varies from 0.021 to 0.078 m/day.
- viii) Purushottam (1980) reviewed seepage loss in various canal systems of India and suggested that seepage may vary from 0.077 to 1.83 m/day depending upon the type of soil.

- ix) Holmes et al. (1981) reported field studies of losses from canals in the Kadulla Irrigation scheme, Srilanka. From Ponding method tests in an unlined canal for an aquifer of relatively low permeability, losses were found to be 0.13 m/day. When a section of lined canal was tested in a similar way, the losses were equivalent to 0.07 m/day.
- x) Deacon (1984) reviewed the existence data on canal seepage losses and suggested the mean seepage rates as shown in Table 2.2.

Table 2.2 Seepage values with respect to material type

Material type	Seepage rate (mm/day)
Average for unlined canals	230
Concrete lining	40
Single tile lining (brick)	50
Double tile lining (brick)	30
Soil cement lining	50

- xi) Wachyan and Rushton (1987) suggested in Table 2.3 the canal losses based on detailed measurements as given for the Periyer Vaigai Project Maduri, South India.

Table 2.3 Canal losses measurements for Periyer Vaigai Project Mudari, South India.

Type of Canal	Seepage rates (unlined) (mm/day)	Seepage rates (lined) (mm/day)
Main canal	370	110
Large distributaries	180	80
Medium distributaries	90	60
Small distributaries	60	45

- xii) Singh (1987) reported seepage losses on the basis of measurements using Ponding method in India in Lined and unlined channels as,

Table 2.4 Seepage rate with to respect to nature of the channel.

Channel type	Seepage of wetted area (mm/day)
Unlined channels	300
Lined channels	30

- xiii) Shahid (1988) reported the typical seepage rates from unlined canals depending upon the soil texture in Table 2.5

Table 2.5 Typical seepage rate from unlined canals for different soil textures

Material	Seepage rate (mm/day)
Clay loam	250 – 750
Sandy loam	1000 - 1500
Loose sandy soils	1500 – 2000
Gravelly soils	3000 – 6000

3. METHODS OF SEEPAGE LOSS ESTIMATIONS IN IRRIGATION CANALS

This chapter discusses the factors affecting the seepage losses. Conceptual and methodological details related to the various techniques for estimations and measurements of seepage losses are presented. At the end an evaluation of the current practices of measurements of the seepage losses has been done.

Seepage is defined as the loss of water through the wetted area of the bed and their banks of a canal. It occurs, in general, as the head difference between the water level in the canal and the watertable in the adjacent lands. Analytical solutions for the steady state seepage from the open channels have been developed by a number of researchers, the pioneers being Kozeny (1931), Vedernikov (1934), Dachler (1936), and Bouwer (1965,1969). Bouwer`s approach covers a wide range of soil conditions, depths and geometry of the channels, water table position than the earlier studies and is evaluated as the most important by the succeeding investigators of the seepage theory. His basic seepage models, depending upon the three commonly occurring natural conditions are presented in Figure 3.1 and described as

- Condition A: The soil in which the channels is embedded is uniform and underlain by more permeable (considered infinitely permeable) material. The water table slopes away from the water surface in the canal and becomes horizontal at greater distances,
- Condition B: The soil in which the channel is embedded is uniform and underlain by less permeable (considered impermeable) material, and
- Condition C: Seepage to a free draining permeable layer in the subsoil represents a special case of the condition, “A” which is obtained by allowing the water table to be at or below the top of the permeable material.

Another case for the seepage occurrence exists when the canal is lined by a natural or artificial slowly permeable layer which controls the seepage, the under lying subsoil is unsaturated with vertical flow at essentially unit gradient in this case.

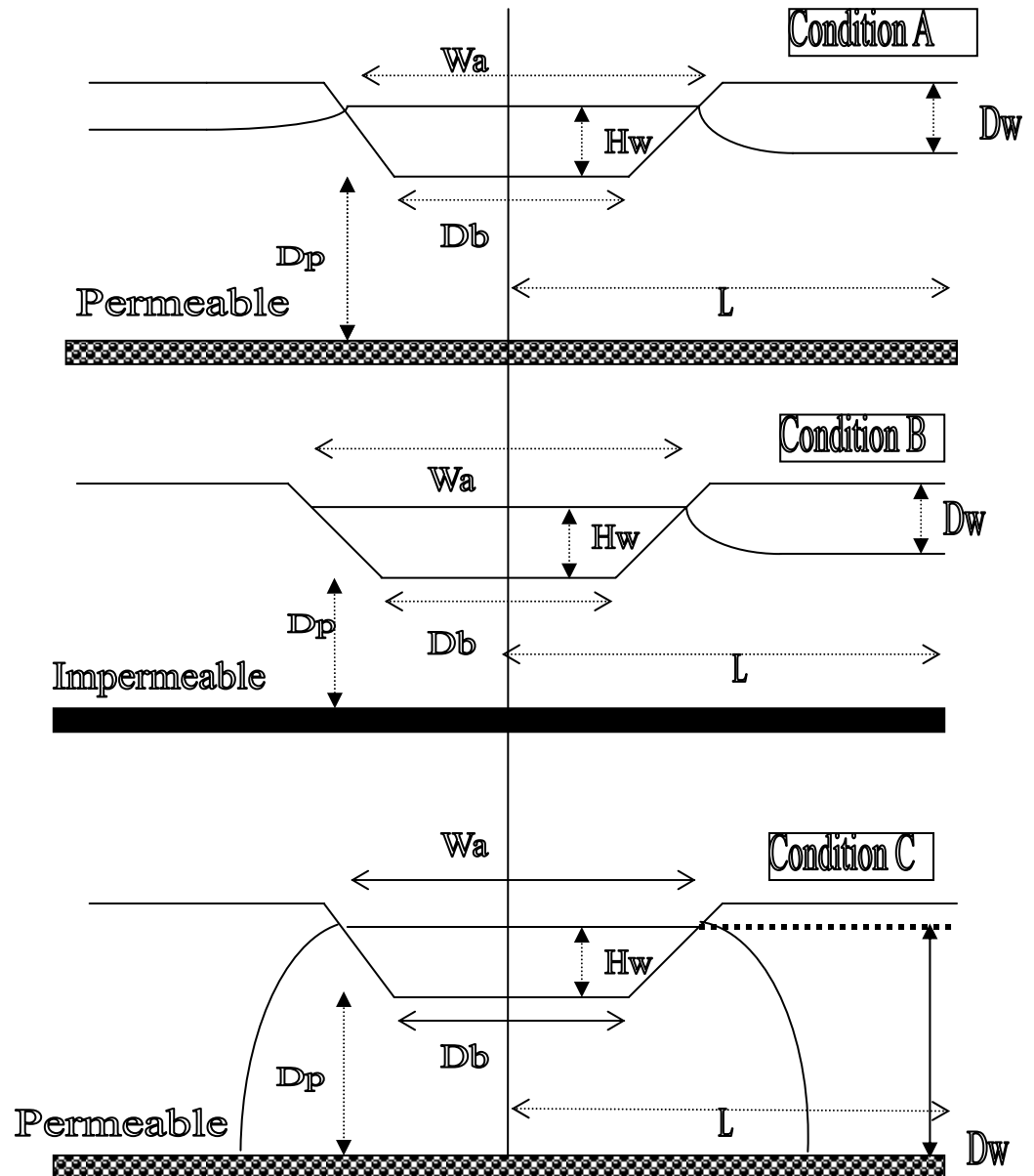

Figure 3.1 Geometry and symbols for seepage conditions A, B and C (after Bouwer 1965, 1969)

The geometry and symbols for the canals under these three conditions are shown in the figure 3.1 in which D_w is the head, affecting the seepage low. The conditions A and B are equal to the vertical distance between the free water surface and the horizontal water table. For condition C, the effective D_w value is equal to $H_w + D_p$.

Seepage is also termed as either absorption or the percolation depending on the position of the water table in the seepage domain. In the case of a deep ground watertable (Condition A) position does not affect seepage and so the water loss process is known as absorption. In the case of high water table conditions, the seepage rate is affected by the position of the water table and is termed as percolation (condition C).

3.1 Seepage Variables

Factors affecting the seepage loss are the same that govern any saturated flow through a porous media (Patten et al., 1963). There are many variables that may have an influence on the loss of the irrigation water from canals. These factors act simultaneously. Therefore, it is difficult to segregate the effect of an individual parameter. The principal variables are as follows,

- Characteristics of the soil at the water interface and below the canals bed,
- Chemistry of the water and the soil,
- The amount of the sediments carried and deposited by the water,
- Length of the time water has been in the canal, both seasonally and total life,
- Water depth,
- Velocity of the flow,
- Temperature of the water and soil,
- Soil capillary tension,
- Position of the water table and water table gradient (cut or fill position), and
- Barometric pressure.

On the other hand, characteristics of the soil include the following factors,

- Partical size,
- Porosity,
- Permeability,
- Chemistry,
- Stratigraphy and, and
- Biological factors.

Finally, the hydraulic gradient depends on,

- The permeability distribution,
- The elevation of the canal water surface above the regional water table, and
- The location of the discharge or the storage zones toward which the water flows.

The seepage rate will be less in fine textured soils, as compared to the coarse textured soils. The canal subsoil that is not saturated with groundwater soil will produce a large rate of seepage. A rise in watertable usually decreases the seepage loss and the extent of the loss will depend on the rate at which groundwater finds its way to drainage channels. The water table may rise above the canal bed and produce a gain (i.e. negative seepage) instead of a loss. The canal located along a side hill or on a ridge or along an upper boundary, with no irrigated lands or wet lands will subject to heavy loss. Conversely, a canal located on lower land will frequently receive drainage or waste water from a higher canal or from irrigated lands above, which may be more than seepage losses and could show a considerable gain.

The temperatures of the water and soil have also same effect on the rate of the seepage loss. An increase in temperature decreases the viscosity of the water, which will increase the rate of the percolation. Kennedy (1895) stated that in the Punjab (Part of India), the rate of seepage of the six warm months from April to September was 39.38 cm (15.5 inches) depth of the water per day or 50 % greater than for the six cool months from October to March, when it was about 26.67 cm (10.5 inches) in depth. One likely explanation for this is that in the high temperature months, the high rate of evapotranspiration lowers the watertable sufficiently to increase the hydraulic gradient of flow from canal to the surrounding lands. The viscosity of water may also affect the seepage losses. The age of a canal can have a significant effect on the seepage losses. A canal will usually become more impervious with age due to the amount of the fine silt carried by the water and the natural process of the sealing of the soil pores.

The depth of water in the channel is usually assumed to be a factor affecting seepage losses. It is sometimes assumed that the seepage loss varies directly with the depth or the square root of the depth of water (Shahid, 1988), However, it should be emphasized that seepage loss may not dependent on the depth of the water alone.

This also depends upon depth of the soil through which seepage water percolates, the direction of the flow of the ground water and its hydraulics gradient. The seepage water travels through a large depth of soil and the depth of water in the canal can have a little influence on the loss. On the other hand, where water percolates through only a short distance into some underlying coarse strata that drains freely, the loss will depend largely on the depth of water. He found that within a small range of water depth in a canal, depth made little difference to the seepage loss.

3.2 Units of Seepage Loss

The seepage loss in canal can be expressed in three different ways as,

- The volume of water lost per unit length of the canal,
- The percentage of the total canal flow lost per unit length of the canal, and
- The average volume of water lost per unit wetted area per day.

The percentage of the flow lost per mile shows general efficiency of the canal in regard to seepage. In general, total seepage losses in conveyance on large irrigation projects, where only small percentages of the canal lengths are lined and vary from 15 to 45 percent of the total diversions (Shahid, 1988)

Most commonly used unit for seepage loss is the “average volume of water lost per unit wetted area per day”.

3.3 Methods of Seepage Loss Estimations

Due to many parameters involved and their variability, studies of the seepage and the seepage measurement have been few and the results are somewhat inconclusive. No entirely satisfactory method for measuring seepage has yet been developed. At best, the methods are more indicators of the magnitude of the seepage rather than precise quantitative measures. These methods can be divided into three main groups:

- Analytical methods,
- Empirical methods, and
- Physical methods.

3.3.1 Analytical methods

The analytical methods for estimation of absorption seepage assume a drainage layer to be present at some distance below the canal bed; and seepage flow is attracted by the layer. The water flows under a unit hydraulic gradient. When no drainage layer is present, an impermeable layer is considered to be present at an infinite depth and the watertable is assumed to be present at such a depth that seepage flow is not obstructed by groundwater mound developed under the canal. In addition, it is assumed that the seepage flow occurs under unit hydraulic gradient before it meets the groundwater mound. In all cases, seepage is considered to be symmetrical about the canal center.

Vendernikov (1934) described a direct method for estimating seepage from trapezoidal and rectangular channels. He derived his results by using the method for inversion and velocity hydrograph. Kozney, Pawlowsky and Vedernikov (referred to in Harr, 1962) all individually at the same time solved the problem of seepage from canals with a curvilinear perimeter using Zhukovsky's function. Morel-Seytoux (1964) showed by the inverse hydrograph techniques, Schwartz Cristoffel transformation and Green Neumann function, that seepage flow rate to identify low water table in a pervious strata, underlain at relatively greater depth by a more pervious one, is dependent upon shape of the channel.

Bouwer (1965) discussed the relationship of the seepage from canals with geometry of the channel, the aquifer permeability and the position of the water table. Brush and Street (1967) presented the study of seepage from an infinite array of parallel trapezoidal channels to an underlying drainage layer by transforming the flow region and boundary conditions therein from the physical plan i.e. (x, y) coordinates. The solution plan was obtained by inverse formulation. The numerical part of the solution was obtained by finite difference method.

3.3.2 Empirical methods

Many researchers over the time have developed some empirical relationship based on the field data collected. These can be explained as follows.

- i Water and Soils Investigation Division (WASID 1963) analysed the results of seepage loss measurements for the canal of Rechna, Chaj and Thal Doabs.

Their studies aimed to relate canal losses with discharge but only 70 out of 300 measurements were considered worthy of future analysis. The bulk of the data was discarded due to inaccuracies in discharge measurements. Their conclusions were that an approximate relationship between discharge and seepage was in the form of a power function as

$$S = CQ^n \quad (3.1)$$

where S = Seepage loss per unit canal mile (cfs), C = Co-efficient of discharge

Q = Canal discharge (cfs), and n = Exponent of discharge

He analyzed the results separately for each Doab. The values of C and n were derived as 0.06 and 0.68, respectively for canals in the Thal Doab, and 0.03 and 0.70 for canal of chaj and Rechna Doabs.

- ii Kraatz (1977) summarized empirical relationships for estimating seepage losses as follows,

Davis and Wilson formula for seepage from lined canals is given as.

$$q_a = \frac{0.45C_1PLH^{\frac{1}{3}}}{(4 \times 10^6 + 3650\sqrt{V})} \quad (3.2)$$

where q_a = seepage losses (m^3/day per length of canal), L = length of canal (m)

P = wetted perimeter (m), H = water depth in canal (m), V = velocity of flow (m/sec), and C_1 = A constant depending on the lining material and have the values as,

$$a = \begin{cases} 1 & \text{for concrete (10 cm)} \\ 4 & \text{for mass clay (15 cm)} \\ 5 & \text{for light asphalt} \\ 8 & \text{for clay (7.6 cm) and} \\ 10 & \text{for asphalt or cement mortar} \end{cases}$$

- iii Moritz formula is given by Kraatz (FAO 1977) as,

$$q = 0.2C_s \left(\frac{Q}{V} \right)^{0.5} \quad (3.3)$$

where q = seepage losses (cfs per mile of canal), Q = canal discharge (cfs), V = velocity of flow , C_s = a constant value depending on soil type, and values of C for different soil types are given in the Table 3.1

Table 3.1 Values of constant “ C_s ” for different soil types.

Soil Types	Value of C_s
Cemented gravel and hard pan with sandy loam	0.34
Sandy and clayey loam	0.41
Sandy loam	0.66
Volcanic ash	0.68
Sand with volcanic ash or clay	1.20
Sandy soil with rock	1.68
Sandy and gravelly soil	2.20

- iv Molesworth and Yennidumia’s empirical formula as used by Egyptian Irrigation Department quoted by Kraatz (FAO 1977) is,

$$q = C'L'P\sqrt{R} \quad (3.4)$$

where q = Total loss (m^3/sec length of canal), L' = length of canal (km), P = wetted perimeter (m), R = hydraulic mean depth (m), and C' = a coefficient depending on nature and temperature of soil ($C' = 0.0015$ for clay and $C' = 0.003$ for sand)

- v The International Commission on Irrigation and Drainage (ICID 1967) reported the following formula for estimating the seepage losses from canals in India.

$$q' = C''AH \quad (3.5)$$

Where q' =Total loss (cfs), A =wetted area perimeter (msf), H = water depth in canal (ft), and C'' = a constant depending upon nature of surrounding material. Observations made on some of the important canals in Indian Punjab showed that C'' ranges from 1.1 to 1.8

For all empirical formulae, the seepage is dependent upon canal geometry and its discharge. The watertable in this case is taken to be efficiently deep, and therefore,

has no effect on seepage rate. These formulae are limited to deep water table conditions only, and hence cannot be applied to many situations where watertable is high.

3.3.3 Physical methods

3.3.3.1 Ponding method

In this method, a selected canal reach is physically isolated by constructing temporary watertight dikes at the head and tail ends of the reach. The reach of canal is selected so as to have the minimum variation in the cross sectional area of the canal. The canal is ponded with water and the drop in water surface with time is measured at different points along the length. The seepage rate is then computed according to the following formula,

$$q_{av} = W(d_1 - d_2)L / pL'' \quad (3.6)$$

Where q_{av} = average seepage m/day over distance L'' , W = average width of water surface of the ponded reach (m), d_1-d_2 = change in depth of water in the canal in 24 hours (m), P = average wetted perimeter (m), and L =length of selected reach (m).

A modification to the above procedure is to add water to the pond to maintain a constant surface stage. The accurately measured volume of added water is considered to be equal to the total average loss rate in the elapsed time. This is the most accurate method of seepage determination and is especially suitable when seepage loss rate is very small. Since the complete test takes a considerable time, evaporation and rainfall must be measured and taken into consideration in calculating seepage losses. The disadvantage of the method is that it cannot be performed when the canal is running. The canal seepage rate measured by ponding method may be slightly lower than when the canal is running because it may be influenced by the canal currents near the bottom due to settling of the suspended silt particles.

The method may be used to measure seepage rate in the lined and unlined distributary canals and can give good results. As this method is comparative accurate, the difference between lined and unlined canals can be easily compared measured by this method. The best time to conduct test is during the closure period

of the canals. It can be either annual canal closure or closure due to rotational program as is practiced in some of the canals.

The ponding method provides an accurate means of measuring seepage and is especially suitable when losses are small. The results from this method are generally used as the standard of comparison for other methods of seepage measurement. Its main advantages and disadvantages can be described as,

3.3.3.1.1 Advantages of ponding method

- a) The test procedures are simple and accuracy of the data observations can generally be quite good,
- b) It can be used during construction stage in completed short lengths of channel to check on the degree of compaction and potential seepage, which may lead to improved work quality, and
- c) Applicable to both lined and unlined canals.

3.3.3.1.2 Disadvantages of ponding method

- a) It cannot be used while canals are operating,
- b) It does not reflect the velocities and sediments loads of operating conditions,
- c) Cost and time of construction bulkheads or ends dikes become limiting with large canals,
- d) Pond may have to be filled several times before seepage rate becomes stabilized, and
- e) It is not possible to locate variation in seepage rates within the pool.

3.3.3.2 Inflow – Outflow method

In this method, all the discharges entering and leaving a canal reach are measured, together with rainfall and evaporation. The difference between the inflows and outflows and the storage is the total loss, including canal seepage, canal fill and evaporation losses.

With this method, it is difficult to relate the losses in one system to those in others. A high level of occurrence is required for the discharge measurements. This method has merit on canals with high losses, and where losses from the long canals reaches are to be measured, so that the seepage loss is a significant percentage of the total flow. WAPDA (1965) suggested the length of the test reach as,

$$L'' = 16 EQ_b / (S_1 P) \quad (3.7)$$

Where L'' = Length of test reach (canal miles), E = Probable percent error in discharge measurements, Q_b = Discharge at the head of the test reach, S_1 = Anticipated seepage rate (cfs in msf), and P = Wetted perimeter of the canal (ft).

This method can be used preferably in the long blind reaches of canal. The methods of discharge measurements should be accurate, otherwise the results will be wrong. Singular structures with free conditions upstream and downstream of the reach are suggested. If there is any off take in the reach, the discharge should be measured correctly. The accuracy of the current metering is normally assumed to be plus or minus 5 to 10 %. All diversions and leaks within the test reach should be carefully measured. Any inflow into the canal from surrounding areas must be taken into account. The leaks that cannot be eliminated are best measured volumetrically with calibrated device. The errors due to personal observations and instruments should be compensated by changing the instruments and also the observer between the head and tail discharge measuring sites.

During the symposium on “Operational and Maintenance of Canal System”, held in India in May 1980, the following conclusions were made on the relative advantages and disadvantages of the various measuring techniques. Important pre-requisites of using inflow-outflow methods were suggested as,

- Attaining and maintaining a steady state of flow throughout the duration of observations,
- Selection of the optimum length of a reach so that the anticipated losses from the reach are of higher order compared to the accuracy of the measuring devices and methodology (which may be taken as plus or minus 5 % for observations with current meters), and,
- Accurate measurement of all outflows and escapades in the reach.

Normally, the current meters are used for measuring the flow in the channels. However, for water courses or small channels also, portable measuring devices like Parshall flumes, standing wave flumes, and V-notches can be used.

Hotes (1985) suggested that this method can be considered as fundamental for the most direct, and potentially correct method if it is conducted properly. This method can have the following advantages and disadvantages.

3.3.3.2.1 Advantages of inflow – outflow method.

- Reflects actual operating (dynamics) conditions,
- Observations can be made without serious interruption of irrigation schedules,
- Equally suitable for all sizes of channels, large or small. However, as the number of branches or turnouts increase, the number of measurements and problems of stabilizing flows also increase, and
- Applicable to both lined and unlined canals.

3.3.3.2.2 Disadvantages of inflow-outflow Method

- Highly trained staff is required to make accurate measurements. Usually this would include technicians skilled in current meter measurements, especially on larger canals,
- It is difficult to maintain channels in a steady state for several days, to make reliable measurements,
- To bring seepage losses within a measurable range, the test reaches have to be fairly long, which may prevent accurate measurement over short stretches of special interest,
- Unless off take gates are closed and made watertight during measurement period, simultaneously measurements of discharges of those off take channels would have to be made. This may involve the deployment of a large number of observation parties,
- If existing structures are to be used for ascertaining discharges, they must be calibrated,
- It is difficult to relate the loss in one system to those in others, and
- Areas of high or low seepage within that reach are not identified.

3.3.3.3 Seepage meters

A seepage meter measures the total amount of water flowing into underlying ground. The seepage through the bed and the side of the canal needs to be measured. A

metallic bell is inserted well into the canal bed /side. The change in water level over the bell column is then measured. The drop in water level is related to the seepage rate. The location should be representative of the canal section being measured, but many measurements at different locations are needed.

The method cannot be used for velocities greater than 0.6 m/sec. The seepage meter is a delicate instrument and usually produces inaccurate results. It is difficult to install on the sloping canal banks and unavoidable fluctuations of the water surface level in the flowing canals can introduce large errors.

WAPDA (1965) performed several preliminary tests on minor canals and watercourses in the Lower Indus Region. The results obtained were reported to be disappointing mainly due to numerous inherent sources of error in the method.

3.3.3.3.1 Merits

- The meters are useful for speedy observations of seepage losses at specific locations, and
- Reaches with excessive seepage rates can be identified

3.3.3.3.2 Demerits

- It is difficult to install the meters in water depths more than 0.9 m (3 feet),
- The method cannot be used in gravel or rocky soils,
- It is difficult to install the meters on steep sloping canal sides,
- If water velocities are more than 0.6 m/sec (2 ft/sec), then use of meter is very limited, and
- The meters have to be left in place for hours or days before meaningful seepage rates can be determined.

3.3.3.4 Ground water elevation analysis

The analysis of the groundwater elevations in relation to the canal level indicates the places of seepage losses and gives a rough indication of the quantity of the losses (Bouwer, 1963). Transects of piezometers installed at right angles to the direction of canal and extending out beyond the canal to record the natural level of the surrounding ground water, can give information on seepage gradient, magnitude and direction of the seepage flow. The useful information on establishing an observation network for ground water survey has been given by De Ridder (1980).

3.3.3.5 In-place measurement of permeability

This method gives an indication of the permeability of the material and, therefore, of the seepage potential. The results of soil surveys and extensive determination of the in-place permeability of the adjacent soils along the canal are used to calculate an estimated seepage.

The US Bureau of Reclamation experience has been that simple equations based on seepage theory (Bouwer, 1965); (Glover, 1974) and others can reproduce measured canal seepage rates within 15 percent (Christopher, 1981) provided that all necessary field data have been obtained. This approach should be used only if the soil is, under, and adjacent to the test section is thoroughly described, tests for hydraulic conductivity (permeability), and the water table level in relation to the canal is monitored.

3.3.3.5.1 Advantages of in-place Measurement of Permeability

- Reflects actual operating (dynamic) conditions,
- Provided seepage estimates, which need not be corrected for evaporation,
- Observations can be made without interruption of irrigation schedules,
- Suitable for all sizes of the canals,
- For all but very small canals, may require less resources (personnel and money), and
- Data obtained provide complete understanding for the seepage process for any situation.

3.3.3.5.2 Disadvantages of in-place measurement of permeability

- Requires well trained crews and competent in performing in-situ hydraulics conductivity test of soils, soil survey crews and experienced supervising personnel competent in groundwater hydrology,
- In locations, where two or more canals exits, it may be difficult or impossible to estimate the seepage contribution of each,
- Difficulty to quantify seepage for relatively short sections of canals,
- Theory not applicable to lined canals, although basic ground water studies can provide values of seepage from such canals, it is usually for only longer periods of time, and

- Evaporation losses must be added to estimate seepage losses to give total transmission losses.

3.3.3.6 Laboratory permeability tests

Information similar to the above can be obtained from collecting undisturbed soil samples along the course of the canal and then undertaking permeability measurements in the laboratory.

3.3.3.7 Electronic logging

This method can be used for estimating or locating that area in which seepage losses are heavy. These measurements can be made during canal operations without interfering with deliveries of water and at any season of the year (USBR, 1954)

3.4 Overall Evaluation of the Seepage Methods

Hotes (1985) reported that tests using both the ponding and the inflow-outflow methods have shown considerable variations, although not as much as do seepage meters. However, they suggested that these variations should be considered normal as evidenced from US Agricultural Research Services studies cited previously.

Critics of the inflow-outflow method sometimes argue that current meter measurements used both to calibrate gates and other control sections as well as for flow measurements are not accurate enough. Carter (1970) has demonstrated that current meters can measure flows with an error of 2 to 3 percent or less when a skilled crew is engaged for measurements. Earlier, Kolupaila (1964) presented an excellent illustration of how high error percentages may result, even when gauging is done by highly experienced persons.

Robinson (1981) argued that the inflow-outflow method may give reasonably good data for overall seepage losses but specific area with high losses is usually not located. He further maintained that if seepage losses are great, this method can be successfully used but generally will not pinpoint short sections with high losses. Careful and accurate measurement of all inflow and outflows are necessary including evaporation. However, under normal condition current meter measurements usually have a range of error of plus or minus 5 %. This variability may result in a sizeable

error in the inflow-outflow measurements. If seepage is very large percentage of the canal flow, the significance of this measurement error may not be high.

The ponding method is considered as the most accurate means of the measuring seepage losses Robinson (1981), Hotes (1985) and others and it is especially suitable for small canals. If ponding section is long localized areas of high seepage rates will not be apparent. The ponding method can be used to study seepage loss in specific short reaches. Further, the method is only suitable for determining the seepage losses in channels carrying a discharge less than $19.8 \text{ m}^3/\text{sec}$ (700 cusec) because of the difficulty regarding time, cost and practicability of constructing watertight end dikes and replenishment of water in the pool to maintain in constant head. For greater accuracy of the results, double end dikes should be used. The seepage meter method affords speedy observation of seepage losses at specific locations and can be helpful for identifying reaches with excessive seepage loss rates, but it cannot be used for reliable assessment of the seepage losses for a large system

Seepage studies by the US Agricultural Research Services quoted by Hotes (1985), demonstrated that seepage meters give highly variable results. Results showed that forty-fold range occurred, with average seepage rates about 10 times that obtained from the ponding tests. United States Bureau of Reclamation Experience and Christopher (1981) also confirm that seepage meters are seldom reliable for quantifying losses. The seepage meter results, if extrapolated over the entire cross-section of the canal can indicate considerable higher seepage rates than those obtained by using other methods. Therefore, the seepage meter results must be viewed with some skepticism. Hotes (1985) pointed out that seepage meters are the least reliable method, although they can be useful in establishing qualitative comparison and in identifying canal sections with excess seepage for unlined channels.

4. SEEPAGE CONTROL MATERIALS

Geosynthetics is the collective term applied to thin, flexible, sheets of material incorporated in or about soil to enhance its engineering performance. Applications of geosynthetics fall mainly within the discipline of civil engineering and the design of these applications, due to the use of geosynthetics with soils, is closely associated with geotechnical engineering. The professional groups most strongly influenced are geotechnical engineering, transportation engineering and environmental engineering. All soil, rock and ground water related activities fall within the general scope of these applications.

The use of geosynthetic materials in geotechnical structures is still relatively new. Geo of course, refers to the earth. The realization that the materials are almost exclusively derived from human made products gives the second part of the name, i.e. synthetics. The American Society for Testing and Materials (ASTM) has defined geosynthetic as “planar product manufactured from polymeric material used with soil, rock, earth, or other geotechnical engineering related material as an integral part of a man-made project, structure, or system”. The geosynthetic materials, therefore, perform five major function separation, reinforcement, filtration, drainage and liquid barrier.

In terms of classification of geosynthetics the major division is between geotextiles and geomembranes, each serving different purposes.

4.1 Geotextiles

Geotextiles are defined by the American Society for Testing and Materials (ASTM, 1991) as “any permeable textile material used with foundation, soil, rock, earth, or any other geotechnical engineering related material as an integral part of a man-made project, structure, or system”.

4.1.1 Geotextile functions

The relatively thin geomembrane can be damaged easily, both during installation of the sealing system as well as after completion of the construction if no adequate mechanical protection is provided. By using a suitable geotextile in combination with the membrane, the danger of damage to the sealing system can be reduced substantially. In FESS (Fordwah Eastern Sadiqia South) Canal Lining Project geotextile is being used for two purposes as,

- To protect the geomembrane against mechanical damage or puncture during installation, and after completion of construction, and
- To provide friction so as to prevent the slippage of direct applied concrete on the sides of canals.

4.1.2 Installation

The geotextile layer is comprised of pieces as large as practicable, preferably with the long dimension of each piece lying along the canal. Junctions between the adjacent pieces would be plain overlaps of not less than 6 inches (152 mm) used extensively as filters which retain soil while allowing water (or other fluids) to seep through (Purdy, 1983). The major functions of geotextiles include separation, filtration, drainage and reinforcement (Giroud, 1985). The geotextile acts as a separator when placed between dissimilar materials and protects the geomembrane when placed over it. Geotextile may also provide reinforcement by adding tensile strength to earth materials and improving stability (Schmidt, 1985). They may also function as drains by providing a conduit or flow channel for transportation of water or other fluids within the plane of the fabric (Christopher, 1982).

4.1.3 Growth Rate of Geotextile Applications

Growth of geotextile uses in the United States, Canada, and Europe has been extraordinary. Holliday (1982) found less than 4 million sq. m (5 million-sq. yard) in use in the U.S in 1971, increasing to 8 million sq. m (10 million sq. yard) in 1981. The Industrial Fabrics Association International (IFAI) reported an increase in geotextile use from 220 million sq. m (264 million sq. yard) in 1987 to 298 million

sq. m (357 million sq. yard) in 1991, with a projection for 275 million sq. m (382 million sq. yard) in 1992. The IFAI's projection for the year 2000 in North America is 516 million sq. m (617 million sq. yard) of geotextile material (Koerner, 1994).

4.2 Geomembranes

Geomembranes are the other largest group of the geosynthetics after geotextiles, Geomembranes are defined by the American Society for Testing and Materials (ASTM, 1988) as “very low permeability synthetic membrane liners or barriers used with any geotechnical engineering related materials so as to control fluid migration in a human-made project, structure or system”.

4.2.1 History of the Geomembranes

The early development of geomembranes is quite separate from geotextiles materials. The basic polymers, which are used in some modern day geomembranes, came into production in the thirties starting with PVC in 1933. In 1938, natural rubber with Sulphur, resulting in synthetic rubber was introduced which is a thermoset polymer. The rubber industry was greatly stimulated by the cutoff of natural rubber supplies during World War II. Today the production of various synthetic rubber materials is a major industry. The original geomembrane was a rubber product and was used as a potable water pond liner (Ingold, 1994).

Many other combinations and variants of rubber material are possible e.g., nitrile, ethylene-propylene-dienterpolymer (EPDM), etc. However, almost all of the geomembrane materials fall into the category of polymers classified as thermoplastic materials. These are materials that by definition become soft and pliable when heated and are readily seamed by heat, extrusion or chemical means without any substantial change in inherent properties. When cooled they revert back to their original properties (Koerner, 1994).

PVC appears to be one of the first polymeric materials used for lining. Staff (1984) reported PVC sheet being used for lining swimming pools in the late 1930's. Water storage and transportation related trials were practiced by the Bavarian Highway Department using low density polyethylene seepage barriers in the late 1930's (Bell and Yorder, 1957). Pioneering work was carried out by Utah State University using

PVC liners for water storage ponds and butyl rubber for canal linings (Lauritzen and Peterson, 1953).

A research-oriented approach towards the lining of water canals was undertaken by the U.S. Bureau of Reclamation in the 1953. The research was performed by Lauritzen (1953) who worked close with the manufacturer and resin suppliers. Polyvinyl chloride (PVC) canal liner installation was made in Canada, Russia, and Taiwan and also in Europe throughout the 1960s and 1970s. In 1960, a PVC geomembrane was used on the upstream face of the Terzaghi dam to compensate for cracking anticipated to occur in underlying clay blanket (Lacriox, 1984).

In Germany, there was pre-war application of low density Polyethylene (LDPE) Geomembranes for subgrade protection and high density Polyethylene first came into commercial production around 1955. Much like North America, early application of geomembranes did not start to develop until the early 1960s. At this time bitumen reinforced with woven Polyamide fabric was developed in Holland for canal lining whilst PVC was used for lining of tunnels, dams and raw water storage facilities (Bell and Yoder, 1957).

Polyethylene (PE) is formed by the polymerization of compounds containing an unsaturated bond between the two carbon atoms. The late 1960's witnessed an explosion in the number of polymers on the market and this situation was magnified by the flow of polymer technologies between Europe and North America. More economic methods of polymerization, established in the USA, were adopted in Europe while polyethylene polymer and production technology, especially for medium and high density polyethylene, flowed from Europe. Later, alloying techniques, particularly for high density polyethylene, were developed in South Africa (Ingold, 1994).

An other early geomembrane, chlorosulfonated polyethylene (CSPE), resulting from the reaction of chlorine and sulfonyl chloride on polyethylene, was introduced for reservoir and land fill liners in the early 1970s, and this geomembrane type was used in USA and Europe and created a major impact. Today, geomembranes are manufactured and distributed the world over, making all type of products readily available. The term geomembranes is not widely used in the USA but instead of geomembranes are referred to as pond liners, or just liners, or in the case of hazardous waste containment, flexible membrane liners (FML). Guidelines for

flexible membrane linings have been issued by the American Society of Agricultural Engineers (ASAE).

4.2.2 Manufacture

Manufacturing of the geomembrane begins with the production of the raw materials, which include the polymer resin itself, various additives such as antioxidants, plasticisers, fillers, carbon black, and lubricants (as a processing aid). Table 4.1 gives the varying amounts of different materials used to make commercial geosynthetics materials. These raw materials are then processed into geomembrane sheets of various width and thickness.

Table 4.1 Commonly used polymers and their approximate formulations.

Polymer Type	Resin	Filler	Carbon Black	Additives	Plasticizer
Polyethylene	97	0	2-3	0.5-1.0	0
Polypropylene	96	0	2-3	1-2	0
Polyvinyl chloride	80	10	5-10	2-3	30-35
Polyester	97	0	2-3	0.5-1.0	0
Chlorosulphonated polyethylene	45	20-25	20-25	5-7	0

All polyethylene (HDPE, VLDPE, etc.) geomembranes are manufactured by the extrusion method. In this method, the polymer resin, carbon black, and an additive package (antioxidant and lubricant) are pneumatically loaded into the feed hopper of an extruder. The extruder contains a continuous flight screw, and the formulation passes successively through a feed section, and heating section, where it finally emerges as a filtered, mixed, and molten form into a die.

Two variations of extrusion processing are used to make geomembranes. One is a flat die (called cast sheeting) which forces the polymer formulation between two horizontal die lips, resulting in a sheet of closely controlled thickness from 0.75 to 3.0 mm (30 to 120 mils). The width varies from 1.8 to 4.6 m and when two parallel extruders are used the widths can be increased to 9.1 m (30 feet). The second

variation is a circular die (called blown film) which forces the polymer formulation between two concentric die lips oriented vertically, producing a seamless tube which is later cut and laid flat as a sheet whose width is approximately equal to the circumference of the die (Koerner, 1990).

By creating a roughened surface on smooth HDPE or VLDPE sheet, a high friction surface can be created. This process is called texturing and material is called textured geomembrane; by using either co-extrusion or impingement and lamination methods smooth HDPE and VLDPE geomembrane can be textured.

All PVC, CSPE, and reinforced geomembrane are manufactured by a callendering method. In this method, the polymer resin, carbon black, filler, plasticizer and additive package are mixed in a batch (Banbury type) or continuous mixer. During mixing heat is added, which initiates a reaction between the components. The material exits to a roll mill, where it is further blended and masticated. Now in the form of a continuous mass, it is passed through a set of counter rotating rollers (called a calendar) to form the final sheet, geomembrane produce by callendering are available in widths up to 4.4 m (8 ft).

Geomembrane can also be made by a manufacturing method called spread coating. In this method, the modern polymer is spread in a relatively thin coating over a tightly woven fabric, or even a non-woven fabric. Generally the open pore spaces of the fabric are insufficient to allow for penetration to the opposite side so if coating on both sides is required, the material must be turned over and the process repeated.

4.2.3 Geomembrane Application

In 1980, Forbay Reservoir (USA) was lined with chlorinated polyethylene geomembrane. The U.S. Bureau of Reclamation (USBR) lined the reservoir with a continuous polymeric geomembrane due to excessive seepage (Morrison, 1990).

Rawlings (1994) also described the use of the geomembrane as reservoir water proofing in Muna Reservoir Project (Saudi Arabia). The Muna Reservoir Project was planned to provide an adequate supply of drinking water for the pilgrims during Haj season. For water proof lining an impermeable geomembrane was used.

As wide range of uses of geomembrane has arisen, all of which relate to the material's primary function of being impervious. However, nothing is strictly impermeable in an absolute sense. The permeability of the geomembrane is 10^{-11} to

10^{-13} cm/s. In this regard, we speak of geomembrane as being relatively impermeable (Korner, 1994). He described the uses of the geomembrane in environmental, geotechnical, hydraulic and transportation activities as,

- Liners for potable water,
- Liners for reservoir water,
- Liners for waste liquid,
- Liners for water conveyance canals,
- Liners for waste conveyance canals, and
- Liners for solid waste land fills

Montez and Moroni (1990) worked on the used of geotextiles and geomembranes in irrigation channels. Irrigation systems generally demand the construction of channels and reservoirs. According to local soils and project conditions there will in turn require watertight linings. Among the various types of lining available, geosynthetics that is, geomembranes in association with geotextiles, provide technically valid options, are low in cost, and permit rapid installation.

A waste disposal area in Germany was designed in 1979. Due to the difficult topography of the slope surfaces, geomembrane was used on the slope surfaces as a sealing element (Asmus, 1979). Waste containment is now the main use of geomembranes in Europe and North America.

Morrison (1990) proposed the use of geosynthetics for the under water lining of operating canals. The Bureau of Reclamation has some continuously operated irrigation canals that leak, resulting in the loss of a valuable natural resource. Many of the canals cannot be dewatered for lining due to water delivery commitments. The Bureau of Reclamation conducted a research program to study methods and materials for the underwater placement of a geosynthetic flexible membrane lining system utilizing a concrete protective cover. USBR recorded little success in this experiment hoping that development of this technology would permit the lining of earthen canals without draining them.

An Irrigation Project started near Kirkuk, Iraq consists of a 120 km long main canal. The canal transports water of the river Tigris through desert areas. On the way to the city the canal water supplied newly constructed agricultural areas, by means of numerous smaller secondary canals. The main canal passes through regions where the soil large areas, consist of gypsum formations. Erosion of such gypsum formation called dolines has led to the destruction of the whole canal. Such destruction caused

an interruption of the water supply. The decision for the use of an artificial water proofing material (geomembrane) on this project was made for the lining purposes (Koop, 1991). In Pakistan China Beijing Corporation is the pioneer of installing geomembrane under the Fordwah Eastern Sadiqia South (FESS) Canal Lining Project (1997-2004) from whom I have collected data for research purpose.

4.3 FESS Canal Lining Project

Canals are lined for one or more of a number of purposes such as to,

- Reduce seepage losses,
- Reduce maintenance requirements,
- Stabilize the channel and reduce erosion, and
- Improve visual appearance

However, in FESS Irrigation and drainage project, the main purpose of using geomembrane is to reduce the seepage losses, though a reduced maintenance requirement is expected to be a by product. The FESS canal lining component comprises the lining of existing canals within the Fordwah command area. About 130 km of canals with flows up to about 2.8 m³/s (100 cfs) are being lined in the so-called production component, to a relatively high-quality and expensive design comprising as waterproofing element an imported geomembrane, a 0.75 mm thick very low density polyethylene (VLDPE), and as protection to that element an overlying layer of in-situ concrete about 76 mm (3 inch) thick, with the traditional trapezoidal canal shape. A 200 or 350 gm/m² geotextile is placed between the geomembrane and the concrete, partly to protect the geomembrane from damage during installation and partly to prevent sliding of the wet concrete on the 1 in 1.5 side slopes. To reduce the cost, the geosynthetics (geomembrane and geotextile) is extended only to the top of the side slopes and is not anchored as described in contract document (Snell, 1996).

Alongside the production component there are two experimental components being conducted under the same construction contracts. The first comprises fourteen alternative designs being tested on 24 km of canals with flow of less than 2.83 cms (100 cfs) and top width up to 5.79 m (19 ft). The second comprises 10 experiments on innovative ways of using geomembranes to line large existing canals, for instance in the range 2.83 to 14 cms (100 to 500 cfs), though tested on 6.5 km of a 307 cfs

(8.7 cms) canals which is typically 50 ft (15 m) wide. The first fourteen experiments use as geomembrane a thinner and cheaper alternative to the 0.75 mm very low density polyethylene (VLDPE), namely a 0.5 mm flexible polypropylene alloy (FPA).

Normally there is only one water tightness barrier, either concrete with good sealed joints or a geomembrane protected against mechanical damage by concrete, brick or soil. In two experiments, however both types of barrier are provided, and in one of the ten experiments in the large canal the geomembrane has no mechanical protection. It is generally thought that, in canals of this type a geomembrane needs to be protected against damage by animals (especially water buffalo which wallow in canals of all sizes), by maintenance operations, by people removing sand for construction purposes during annual closures, and possibly against theft (Snell, 1996). Following types of experimental lining are exercised in this project. For detailed pictorial view the reader is referred to Chapter 5.

- a) In-situ concrete linings,
- b) Bricks over geomembrane,
- c) Plain precast slabs over geomembrane,
- d) Parabolic precast channels,
- e) Vertical precast walls with in situ concrete beds,
- f) Geomembrane under soil cover,
- g) Reinforced geomembrane, and
- h) Concrete filled mattress.

a) In-situ concrete linings

These comprise of production lining and some of the fourteen experiments, which as well as using the thinner geomembrane, test the effect of omitting the geosynthetics and thus of returning to the conventional in-situ concrete lining that relies on the concrete, with sealed joints, for water tightness. There is no difficulty in applying this lining type up to 2.83 m³/sec (100 cfs), and indeed it could equally well be applied to much larger canals.

b) Bricks over Geomembrane

A small experiment has been included which involves covering a geomembrane, without any protective geotextile, by a single layer of ordinary baked clay bricks, laid on edge in sand-cement mortar.

c) Plain precast slabs over Geomembrane

In this experiment the geomembrane (with or without a protecting geotextile) is covered by plain unreinforced precast concrete slabs about 50 mm (2 inch) thick in small trapezoidal canals with a bed width of 0.90 m (3 ft), side slopes of 1:1, and water depths less than 0.60 m (2 ft).

d) Parabolic precast channels

For the smaller canals, up to about 0.28 cms (10 cfs) parabolic channels have been incorporated in the experiments. They are similar in some respects to the smaller channels being used in North west frontier province (NWFP) at Swabi salinity control and reclamations project (SCARP), but the canal slopes in that location are 5 to 10 times greater than those of FESS area so the small canals can take up to 5.66 cms (20 cfs) there. The units are laid at on a flat earth surface and soil is then placed and compacted around them so that they are supported on compacted backfill. The shape of the precast is parabolic having a thickness 76 mm (3 inch) and concrete is unreinforced and the unit are lifted and placed with the help of a crane.

e) Vertical precast walls with in-situ concrete beds

This family of designs is aimed at achieving quick installation, potentially during closures and thus without diversion channels using free standing retaining wall shaped precast concrete side walls, so as to avoid the need for accurate trimming of earthen sides which slows down construction of all the trapezoidal designs, both precast and in-situ.

f) Geomembrane under soil cover

The purpose of this experiment is to test the idea that, in mature regime alluvial canal, most of the seepage is through the sandy beds rather than the largely cohesive sides. A geomembrane is inserted in the bed only and covered by the soil. The lining system is tested in the 8.70 cms (307 cfs) canal.

g) Reinforced Geomembrane

The larger canal experiments use the 0.75 mm VLDPE geomembrane as the production component, but an experiment is being conducted with a reinforced FPA

geomembrane, a geomembrane that is flexible but not extensible. This is used on the bed only with 30 cm (1 ft) soil cover.

h) Concrete filled mattress

The last experiment is used fairly widely for bank protection in navigation canals, harbours, and rivers but not much in irrigation canals. A mattress is first laid on the canal bed and sides which consists of two layers of fine-mesh woven geotextile joined by threads about 50 to 76 mm (2 to 3 inch) long. Once it is in place, fine aggregate concrete is pumped into the space between the layers. The mattress can be filled either in the dry or under water, and both methods are being tried in the experimental lining.

4.4 Geomembrane properties

The vast majority of geomembranes are thin sheets of flexible thermoplastic polymeric materials. These sheets are manufactured and prefabricated in a factory and transported to the job site, where placement and field seaming are performed to complete the job. This category includes materials listed in Table 4.2, which are principal materials currently in use.

Table 4.2 Geomembranes in current use (Koerner, 1994).

<p><u>Most widely used</u></p> <ul style="list-style-type: none"> • Polyvinyl chloride (PVC) • High density polyethylene (HDPE) • Very low density polyethylene (VLDPE) • Chlorosulfonated polyethylene (CSPE)
<p><u>Less used</u></p> <ul style="list-style-type: none"> • Ethylene inter-polymer alloy-reinforced (CSPE-R) • Linear low density polyethylene (LLDPE) • Chlorinated polyethylene-reinforced (CSPE-R)
<p><u>Relatively new</u></p> <ul style="list-style-type: none"> • Flexible polypropylene (PP) • Elastomeric alloy (EA)

Geomembranes are engineering materials and like any other engineering material their properties are varied precisely according to the material used in their manufacturing and the physical form of the finished product. When geomembranes are used in a specific application, it is for the designer to determine what properties are required.

The properties of the geomembranes fall into categories shown in the following list,

- Physical properties,
- Mechanical properties, and
- Endurance properties.

Each of these properties contributes to the specific function for which a geomembrane is used. The physical properties are those that are important for proper identification of the material such as thickness of the material. The mechanical properties are those that relate to strength of the material. For example tensile strength, puncture resistance test, etc. Endurance properties are important over the life of the geomembranes. Included are resistance to ultraviolet light (which degrades the fabric) and temperature stability when geomembranes are exposed to sunlight. Resistance to chemical and biological degradation is also important when a geomembrane is to be buried in soil for a long period of time. This research study involves only in the testing of physical and mechanical properties.

Geomembranes are subjected to various stresses originated by the environment in the form of physical, chemical and biological parameters. The biological stresses result from the action of micro-organisms living in contact or near the geomembranes. These organisms may be plants or animals. Steiniger (1968) performed tests related resistance to animals. Resistance to root (plants) is also important when geomembranes are buried into soil. A Swiss standard (SIA 280, 1975) was described as a procedure for testing the root resistance of materials. Irshad (1991) found the damaging effect of weeds on geomembrane lining using a special apparatus that was developed to perform these tests.

4.5 Geomembrane Testing

As beauty is in the eye of the beholder so the perceived properties of geomembranes are a function of the test method and conditions under which the properties were measured. There are two broad classes of test methods,

- Index tests, and

➤ Performance tests

Index tests are generally small scale (i.e. small specimen size) tests that are used by manufacturers to gauge the quality of goods produced during the manufacturing process. They are typically based on methods that are fast, inexpensive and easy to perform. Index tests, however, are not generally useful in predicting the ability of a geosynthetic to withstand the installation stresses and in service condition for example tensile and tear strength, puncture resistance etc. Index tests are also used as reference tests (Frobel, 1981).

Performance tests, on the other hand, attempt to simulate in the laboratory the conditions and stress that a geosynthetic will experience in actual field applications. These tests are generally slower, expensive and sometimes difficult to perform. They are, however, necessary to accurately predict field performance and it is recognized that performance test results can and are being used in the design process (Rigo, 1991).

Several noted researchers including Rigo (1977), Frobel (1981), Fayoux (1984) and Laine (1989) have demonstrated the various testing devices developed to simulate an in-service quantitative puncture performance test of geomembrane or geomembrane/geotextile combinations. Irshad (1989) also described the effects of animal trespassing on geomembranes and an artificial animal hoof for testing geomembranes under controlled conditions was designed and manufactured.

4.6 Methodology

The geosynthetics research work was carried out by author and two Engineers M. Shahid and J. Nasir, Research Associates under the supervision of M.J Snell, Geosynthetics expert and canal lining advisor for FESS project, at Engineer's Geosynthetics Laboratory established under FESS Project Bahawalnagar. Following properties of various geomembrane materials that are specified for the canal lining were tested,

- Physical properties, and
- Mechanical properties.

4.6.1 Physical properties

By definition geomembranes are thin, impermeable and flexible sheet materials, which are substantially two-dimensional. There are two basic physical tests that govern the dimension of the geomembranes,

- Thickness test, and
- Stiffness (Flexibility) test.

4.6.2 Mechanical properties

The mechanical properties of the geomembrane materials were evaluated by applying loads to the geomembranes and measuring the response. The mechanical properties were tested by the following tests.

- Tensile strength test,
- Tear resistance test,
- Slow puncture test,
- Rapid puncture test, and
- Seams test.

4.6.3 Laboratory tests on Geomembranes

The major part of the programme involves geomembranes, which in this context are essentially impermeable flexible membranes of synthetic material whose purpose is to prevent loss of water from a lined canal. Testing concentrates on the physical properties of geomembranes relevant to their performance for this purpose, and covers neither their chemical nature nor their resistance to heat or radiation. There are several different standard tests for some geomembrane properties, especially puncture resistance; this testing programme's objective (a) requires the use of different tests so as to establish correlations or other relationships between them wherever possible. The tests used are listed in Table 4.3, which shows the normal number of samples for each test, for some tests, additional samples of selected materials are also tested to check on variability of results.

Table 4.3 Tests Performed on Geomembranes (ASTM, 1995)

Test ref.	Type	Standard	No of samples of each material
Tests using tension-compression machine (recording force-displacement curve in each case)			
A	Slow puncture: tapered probe	FTMS 101C 2065.1	3
B	Slow puncture: 8mm cylinder	ASTM D 4833	3
C	Slow puncture: pyramid over water	ASTM D 5494 Method A	3
D	Slow puncture: pyramid over aluminum	ASTM D 5494 Method B	3
E	Slow puncture: CBR method	BS 6906:4 & DIN 54307	3
F	Dumbbell tensile test (two sample directions)	ASTM D 638 & D 882	3 in each direction.
G	Strip tensile test (25 mm strip) on plain sample	ASTM D 882	3 in each direction
H	Strip tensile test (25 mm strip), joint in shear	ASTM D 882	3
<i>Continued Table 4.3 Tests Performed on Geomembranes (ASTM, 1995)</i>			
I	Strip tensile test (25 mm strip), joint in peeling	ASTM D 882	3
J	Graves tear test	ASTM D 1104 or D 624-C	3
Other dry tests			
K	Stiffness test (report overhang length 2c, not flexural rigidity G)	ASTM D 1388	3 in four times each
L	Rapid puncture: drop cone test, over air	BS 6906:6 or EN 918	3
M	Rapid puncture: drop cone test, over water	NT Build 243	3
X	Thickness	ASTM D 751 or similar	10
Hydrostatic test			
N	Hydrostatic cone puncture test	ASTM D 5514	up to 5

4.7 Source of Materials

Table 4.4 lists the geomembrane materials (and a few geomembrane-geotextile composites) which were each subjected to all the above tests, except in some cases where not enough sample material was available. Materials 133 and 211 are the

geomembranes used in the canal lining for the production lining and the main experimental lining types, respectively. Materials 191 and 516 were ordered and used in other experiments. Other materials were derived from the following sources,

- Ordered through the lining contract and delivered by CBC (China Beijing Corporation, the Contractor for the lining contracts),
- Various polyethylenes and polypropylene alloys kindly donated by UK (who also provided material 211 to CBC),
- Some polyethylene samples kindly provided by Poly-Flex Inc. of USA (who also provided materials 133 and 191 to CBC),
- Two polyethylenes with the trade name Carbofol, kindly donated by Naue Fasertechnik of Germany,
- Various samples provided by bidders for the lining contracts in about 1996, some of which are of unknown origin and nature,
- Two samples kindly donated by the Irrigation Research Institute in Lahore (IRI), and
- Several samples from various sources in Xinjiang Province, China, provided through Mr. Plusquellec of the World Bank in connection with the Tarim II Project in China.

Table 4.4 Geomembrane Materials Tested

Mat Ref. No.	Description	Thickness (mm) (approx)	Sample Source	Remarks (sample reference)
Polyethylenes				
111	HDPE	0.5	SGS	ME 693-2-6521 HUBRON
112	HDPE	1.0	CBC	agru PE-HD 1.0MM G/G 1997
113	HDPE	1.5	SGS	Borealis ME6953 Polyplast M/B
114	HDPE	0.75	SGS	Borealis ME6953 Golliods M/B
121	LDPE	0.75	SGS	2002 LID SAMPLE
123	LDPE		IRI	
131	VLDPE	1.0	SGS	ENICHEM: CLEARFLEX +2612
132	VLDPE	1.0	SGS	DOW

133	VLDPE	0.75	CBC	Production component
134	VLDPE "PolyFlex"		Ch.-A.- Hussain J.V.	
135	Polyflex "Dura-Flex"	0.3	Polyfelt 1/98	
136	Polyflex "Dura-Flex"	0.45	Polyfelt 1/98	
137	Polyflex "Dura-Flex"	0.9	Polyfelt 1/98	
161	Carbofol	0.95	Naue Fasertechnik	
171	Carbofol	0.95	Naue Fasertechnik	
181	"HDPE/LLDPE/ LDPE	0.5	Urumchi mid-1998	unknown mixture
182	"HDPE/LLDPE/ LDPE	0.8	Urumchi mid- 1998	ditto, small sample
191 (ex 431)	two-side-textured PE		PolyFlex via CBC	used in canals
Polypropylene Alloys				
<i>Continued Table 4.4 Geomembrane materials tested</i>				
211	GSE/SGS FPA	0.5	CBC	experimental linings
212	GSE/SGS FPA	0.5	SGS	SAMPLE ORDER 23
213	GSE/SGS FPA	0.75	SGS	PolyProp CA 721 T CABOT
214	GSE/SGS FPA	1.0	SGS	PolyProp CA 721 T CABOT
Other unreinforced thermoplastics				
310	unknown, black, "GSE"		Ch.-A.- Hussain J.V.	LVL 020N000 B05030 375
311	ditto, probably "Ultraflex"		unknown (Ultraflex)	LVL 020N000 B05030 476
312	ditto, probably "Ultraflex"		unknown (Ultraflex)	LVL 020N000 , B05030 479
313	unknown, black		Ch.-A.- Hussain J.V.	
331	unknown, clear		unknown	small sample
332	unknown, clear		China Chengdu	
341	PVC film		from CBC	light blue
Unreinforced rubbers and similar materials				
421	EPDM one side black, other silver	1.8	from CBC	DURABIT BAUPLAST

441	Unknown, rubber-like	1	from CBC late 1/98	probably from Austria
Reinforced geomembranes:				
511	Mizu sheet		Irrigation Research Inst	
513	unknown		unknown	black, small sample
514	unknown		China Chengdu	red-white-blue
515	unknown		China Chengdu	colourless
516	Reinforced polypropylene		offcuts from 3R-Hakra experiment G	
Composite materials (geomembrane and geotextile bonded together)				
610	unknown		China Chengdu	"600 g/m ² "
611	unknown		China Chengdu	"600 g/m ² "
612	unknown		China Chengdu	"600 g/m ² "
613	unknown		China Chengdu	"700 g/m ² "

There are many standards already adopted in the plastics, rubber, roofing, and water canal divisions of ASTM and also by the National Sanitation Foundation (NSF). Under the present report, the ASTM (American Standard for Testing Materials) Standards are followed for the laboratory testing of the various geomembrane materials.

4.8 Laboratory Tests on Geotextiles

Geotextiles are permeable textiles whose purposes in this context are to protect a geomembrane from damage during installation and service in a canal lining, and also sometimes to prevent wet concrete slipping when placed on sloping canal banks. The tests performed on geotextiles are listed in Table 4.5, and the materials examined in Table 4.6.

Table 4.5 Tests performed on geotextiles (ASTM, 1995)

Test ref.	Type	Standard	No of samples of each material
Tests using tension-compression machine: (recording force-displacement curve in each case)			
A	Slow puncture: tapered probe	FTMS 101C 2065.1	3
B	Slow puncture: 8mm cylinder	ASTM D 4833	3
E	Slow puncture: CBR method	BS 6906:4 & DIN 54307	3
P	Grab test	ASTM D 4632	3
Other dry tests:			
L	Rapid puncture: drop cone test, over air	BS 6906:6 or EN 918	3
M	Rapid puncture: drop cone test, over water	NT Build 243	3
X	Unit mass	ASTM D 5621 or 3776	5

Table 4.6 Geotextile materials tested

Material ref. No.	Description	Sample Source	Remarks
T-11	Light polypropylene	from CBC	ATC 5501 STD
T-12	Light polyester	from CBC	ANR 5950 STD
T-13	Light thermal-bonded	from CBC	ANR 5501 STD
Table 4.6 Geotextile materials tested			
T-21	Heavy polypropylene	from CBC	DCT 600 STD
T-22	Heavy polyester	from CBC	not yet delivered
T-23	Heavy thermal-bonded	from CBC	STD 600
T-31	Light staple-fibre	Naue Fasertechnik	Secutex 151 GRK2
T-32	Medium staple-fibre	Naue Fasertechnik	Secutex 201 GRK3
T-33	Heavy staple-fibre	Naue Fasertechnik	Secutex 301 GRK4
T-41	Thick grey geotextile	Austria Jan.1998, unknown type	

4.9 Sample and Test Specimen Labeling System

Both the materials samples and test pieces (specimens) were marked with a silver marker (to avoid confusion, and since many samples were similar in appearance) for the proper identification. Each sample was labeled with its material reference number

e.g. 131, where the first digit represent the class, here polyethylene, the second digit represent the sub-class, here VLDPEs and the third digit is an arbitrary number within that class, here indicating the one provided by the SGS laboratory. Each test specimen was labeled with its material number, test reference, and piece number e.g. 131/F/2 means material 131, test F (i.e. Dumbbell tensile test), piece 2 (out of three pieces). Same procedure was adopted for geotextiles.

4.10 Physical Tests on Geosynthetics

4.10.1 Thickness test

Thickness is one of the basic physical properties used to control the quality of many geosynthetics materials. Thickness can be defined as “the distance between one planar surface and its opposite parallel and planar surface of the materials measured under a specified pressure and time”. There are different standard for measuring thickness of geomembranes and textiles. The procedure is the same but difference is only in pressure applied during measuring thickness.

The thickness of geomembrane and geotextile material is determined by observing the perpendicular distance that a moveable plane is displaced from parallel surface by geomembrane material while under a specified pressure, i.e. for geomembrane the pressure is 20 kpa (2 psi) for 5 seconds and for geotextile the pressure is 2 Kpa (0.2 psi) for 5 second.

The determination of thickness of geomembrane and textile were performed by a straightforward measurement. The test used an enlarged -area micro meter under a specified pressure resulting in the desired value. ASTM D 5199 was the test method for measuring thickness of geomembranes and ASTM 751 for textile.

4.10.1.1 Apparatus

Two types of the apparatus can be used to measure thickness, these are,

- a) Thickness gauge, and
- b) Thickness testing instrument.

a) Thickness Gauge

The gauge used for the measurement of thickness is of the dead weight type equipped with a dial graduated to read directly to 0.025 mm (0.001 inch). Usually

this type of thickness gauge is used in field and they are normally hand operated instruments.

b) Thickness Testing Instrument

The thickness measuring instrument have a base (anvil) and a free moving presser foot plate whose planner faces are parallel to each other. The gauge with a 6.35 mm (0.250 inch) diameter presser foot was used for laboratory measurements of the geomembranes. The instrument was capable of measuring a maximum thick of at least 10 mm to an accuracy of at least 0.002 mm (See Figure 4.1).

4.10.1.2 Sampling

For laboratory testing, a full width sample of sufficient length along the selvage or edge of the roll is used. For sampling purpose, specimen should be nearer taken than 152 mm (6 inches) from the edge excluding the inner and outer wraps of the roll or any material containing folds, crushed areas or other distortions not representative of sampled lot. Specimen should be extended beyond the edge of the presser foot by 10 mm (0.39 inch) in all directions i.e. at least a circle of 75 mm diameter.



Figure 4.1 Digimatic Indication for measuring the thickness of geosynthetics

4.10.1.2 Sampling

For laboratory testing, a full width sample of sufficient length along the selvage or edge of the roll is used. For sampling purpose, specimen should be nearer taken than

152 mm (6 inches) from the edge excluding the inner and outer wraps of the roll or any material containing folds, crushed areas or other distortions not representative of sampled lot. Specimen should be extended beyond the edge of the presser foot by 10 mm (0.39 inch) in all directions i.e. at least a circle of 75 mm diameter.

4.10.1.3 Procedure

The procedure followed for thickness measurement suggests adjusting the instrument at zero scale, lift the plunger, center the test specimen on the base under the pressure foot and bring the pressure foot into contact with the material. The pressure is gradually increased to specified pressure. After the full force has been applied by plunger for 5 seconds against the specimen, the dial reading is observed and thereafter the specimen is removed from the test device. The method is repeated for each of remaining specimens and the average of the ten measurements is taken as the average thickness.

4.10.2 Stiffness Test

This test is only performed for geomembrane. Stiffness of geomembranes was measured by following the Cantilever Test Method (ASTM D 1388).

Definitions regarding to stiffness test

- a) **Stiffness:** Resistance to bending.
- b) **Flexural rigidity:** Generally, resistance to bending. Resistance to bending or flexural rigidity is called flex stiffness.
- c) **Bending Length / Overhang length:** A bending length is a measure of the interaction between geomembrane and fabric weight. Bending of fabric under its own weight is the fabric stiffness. It reflects the stiffness of the fabric when bent in one plane under the force of gravity. Half of this length is called overhang length of the material.

4.10.2.1 Summary of the Method

A strip of geomembrane is slid in a direction parallel to its long direction, so that its end projects from the edge of a horizontal surface. The length of specimen is depressed under its own weight to the point where the line joining the tip to the edge

of the platform makes an angle of 41.5° with the horizontal. This method is also known as the single cantilever test. (See Figure 4.2)

4.10.2.2 Apparatus

The apparatus used for stiffness test having following parts,

a) **Horizontal Platform**

It has a horizontal platform with a minimum area of 38 x 300 mm (1.5 by 12 inch) and having a smooth low friction, flat surface such as polished metal or plastic. A leveling bubble shall be incorporated in the platform.

b) **Indicator**

Indicator inclined at an angle of 41.5° below the plane of the platform surface.

c) **Weight**

Weight consists of a metal bar having dimension 25 x 300x3 mm.

d) **Scale and Pointer**

Scale and Pointer are used to measure length of the overhang.



Figure 4.2 Apparatus for stiffness test on geomembrane.

4.10.2.3 Selection and Preparation of Specimens

Test specimens for this test were 25 x 300 mm in size. Four specimens were cut with the long direction parallel to the warp while another four were cut with the long

direction parallel to the filling. Selvages, end pieces and creased or folded places were avoided.

4.10.2.4 Procedure

Place the specimen on the platform with the weight on it so that the leading edge coincides. Holding weight in a horizontal plane, slide the specimen and weighted slowly and steadily until the leading edges projected beyond the edge of the platform. With the eye in a position so that the two inclined lines of the tester coincided, stopped sliding the specimen when its tips falls to the level of these lines. Read the length of overhang from the scale to the nearest 1 mm. Take four readings from each specimen with each side up, first at one end then the other. Determine the weight per unit area of the geomembrane.

4.11 Mechanical Properties

4.11.1 Slow Puncture Resistance Test

Following tests were carried out as a slow puncture tests,

- Slow puncture test: (tapered Probe) FTMS 101C 2065.1
- Slow puncture test: (8 mm cylinder) ASTM D 4833
- Slow puncture test: (Pyramid over water) ASTM D 5494 Method A
- Slow puncture test: (Pyramid over Aluminum) ASTM D 5494 Method B

These tests were treated as index tests and all of these tests varied with shape and size of probe, test speed and clamping methods.

4.11.1.1 Tapered Probe Puncture Test

This test is performed on both geomembrane and textile. This is the federal test method standard titled “Puncture resistance and elongation test” having a 3.2 mm (1/8 inch) radius probe. (FTMS 101 C 2065.1). For this test procedure, a tapered rod probe is pushed through a specimen clamped between two plates with a 25 mm diameter hole. The 12.8 mm diameter, 127 mm long tapered rod is pushed through the specimen at a speed of 500 mm per minute until it punches through it. The taper is 50 mm long with a 3.2 mm radius at the end as seen. The maximum puncture resistance and elongation is recorded. (See Figure 4.3)



Figure 4.3 Universal Testing Machine (UTM) set for slow puncture tests

4.11.1.2 8 mm Cylinder (Probe) Puncture Test

This test is performed for both geomembrane and textile. This standard is entitled “Standard test method for index puncture resistance of geotextiles, geomembrane and related products”, (ASTM D 4833). For this test, a specimen is clamped over an empty mold or ring of 45 mm (1.75 inch) diameter. The assembly is placed in a tensile- compression testing machine fitted with a 8 mm (5/16 inch) diameter probe having a flat surface and 45° chamfered edges as shown in Plate V. The rod is pressed into the specimen until it ruptures the specimen. The recommended test speed is 300 mm /min. The maximum force recorded is the value of the puncture resistance of the specimen. (See Figure 4.3)

4.11.1.3 Pyramid Puncture Test

This test is used to determine the pyramid puncture resistance of plane geomembranes and the geomembranes protected by non-woven geotextiles, (ASTM D 5494). A test specimen is clamped without inducing tension between circular plates of a ring clamp attachment secured in a tensile- compression machine. A force is exerted against the center of the unsupported portion of the test specimen by a solid steel pyramid attached to a load indicator until rupture of the specimen occurs. The maximum load and the elongation record are the value of the puncture resistance

of the specimen. The most important things that distinguish this test from above tests are as follows, (See Figure 4.3)

a) Underlying Test Media

Either water or an aluminum plate can be used as the underlying medium for this test method. If water is used as underlying medium then it is called Method A and if aluminum plate as underlying medium is used then it is called method “B”. The water or aluminum serves as electrical conductor.

b) Loading Piston

The loading piston is a cylinder with a diameter of 25 mm with a polished and hardened pyramid formed apex. This is a four sided pyramid with an apex angle of 90 rounded off with a radius of 0.5 mm. The edges of the pyramid are rounded off with a radius of 0.1 mm.

c) Electrical equipment for the determination of the puncture load

An electrical circuit is employed between the loading piston and the underlying medium (water or aluminum plate) such that puncture resistance load at failure can be determined.

4.11.1.3.1 Procedure

Select the load range of the tensile-compression testing machine such as that the rupture occurred between 10 and 90 % of the full scale load. Employ the electrical circuit between the loading piston and underlying medium “water”, where simulated a non-rigid underlying medium and aluminum simulates a hard and rigid medium. Centered and secured the specimen between the rings with clamps. Use with water as underlying medium. The loading piston pressed into the specimen until the recommended load rate 50 mm/min (2 inch/min) was achieved. The puncture resistance load was registered by the Electric Equipment.

4.11.1.4 Large Scale Hydrostatic Puncture Test

This test method was intended to simulate the puncture behaviour of geomembranes and composite material under a hydrostatic pressure. It was used as a performance test where in actual in service conditions are closely represented using truncated

cones of standard size and shape. ASTM D 5514 was used as standard to follow the test method.

Hydrostatic pressure is used to compress the specimen over a representative sub-grade. This type of test was originally developed by the U.S. Bureau of Reclamation (Frobel, 1981). The sub-grade can consist of natural stone or standardized shapes to simulate different conditions as done by Rigo (1977). Tests using standard shapes utilize some form of pyramid, Frobel (1981), or truncated cones (Koerner 1994). In FESS project, the truncated cones are used for this test, (Figure 4.4)

4.11.1.4.1 Summary of the test

A test specimen of approximately 0.60 m (24 inch) diameter is placed on truncated cones within a high pressure test vessel. Upon adequate sealing of the specimen and closing of the upper portion of the assembly, a hydrostatic pressure is applied to a targeted value or until the specimen fails. The puncture limit is readily noticed by means of a pressure gage drop coincident with failure of the geomembrane. Puncture strength improvement using geotextile as protection layers can also be evaluated with this test method.



Figure 4.4 Hydrostatic puncture test for geomembrane

4.11.1.4.2 Geomembranes involved in test program

Selected numbers of geomembranes (materials available in sufficient quantity) were tested on this apparatus. These included specially 1.0 mm high density polyethylene (HDPE); 1.8 mm Ethylene propylene diene polymer (EPDM), 0.80 mm polyvinyl chloride (PVC), 0.50 mm Flexible Polypropylene Alloy (FPA), 0.75 mm very low density polyethylene (VLDPE), 1.0 mm textured geomembrane and some others as shown in summary sheet.

4.11.1.4.3 Testing device

The test apparatus used for this series of experiments is shown schematically in Plates 4.4. It consists of a pressure vessel generally rated up to 690 Kpa (100 lb/inch²) which can accept a geomembrane test specimen of approximately 0.6 m (24 inch) diameter. Suitable pressure pumps, valves, regulators and gauges are necessary. Lower assembly contains the soil, or truncated cones. Soil sub-grade usually consists of site specific soil, which is used for evaluating the puncture behaviour of a specimen. Truncated cones are used to simulate an angular sub grade. The height of the cone in the vessel can be varied to simulate aggregates of different size.

4.11.1.4.4 Procedure

The test specimen was placed on a flange, which encircles the top of the lower half of the vessel, so that it just touched the cones. The top part of the vessel was then placed on the sample and secured to the lower half by bolts that locked the specimen in place. The top portion of the apparatus has a water intake valve, an air bleed valve, and a pressure gauge. The cones were placed on a supported steel plate form in a triangular pattern with 250 mm distance between the cones. Water was introduced into the top of the vessel, displacing the air until the top half filled with water (approx. 5 inch in depth). The hydrostatic pressure was then increased until the specimen failed or the limit of the system 110 psi (690 kpa) was reached. The rate of pressure rise was 6.9 Kpa/ min. Failure was indicated by a sudden drop in pressure and moisture sensors were also embedded at the tip of the cones to detect puncture failure. Well graded sand is then placed around the cones in the bottom cylinder leaving the required cone height protruding above the sand. The assembly is then placed in the pressure vessel such that the tops of the cones are at the same level as the top of the flange of the pressure vessel.

4.11.2 Graves Tear Test

This test is only performed for geomembranes. This test method covered the determination of the tear resistance of geomembranes at very low rate of loading 50 mm/min. The test is designed to measure the force to initiate tearing. The specimen geometry of this test method produced a stress concentration in a small area of the specimen. The maximum force, usually found near the outset of tearing, was recorded as the tear resistance in Newton's. The test standard ASTM D 1004 or D 624- Die C was followed to perform this test. As described early the specimen shape is very important in this test method. Figure 4.5 shows dia C and other dies used for cutting the geomembrane for making the sample ready for tests.

4.11.2.1 Speed of the Testing

The test is performed on the tensile compression machine. A jaw separation of 25.4 mm (1 inch) is used. The rate of travel of the power activated grip was applied 50 mm (2 inch) /min and remain uniform at all time.



Figure 4.5 Dies used for cutting the sample for certain tests

4.11.2.2 Procedure

Measure the thickness of the specimen at several points. Place the specimen in the grips of the testing machine so that the long axis of the enlarged ends of the specimen was in line with the points of attachment of the grips to the machine. Applied the load at 51 mm /min rate of grip separation and after complete rupture of the specimen, the maximum tearing load in Newton's was recorded as a result.

4.11.3 Tensile Strength Test

This test is only performed for geomembranes. Following two tests methods were conducted for the testing of tensile strength of various geomembrane materials.

- a) Dumbbell tensile test ASTM D 638
- b) Strip tensile test ASTM D 882

4.11.3.1 Test procedure

Place the specimen between the grips. The initial gauge length (Jaw Separation) should be 25 mm. One jaw is fixed and the other is moved at a constant speed of 50 mm/min. The test is performed on the Tension-Compression Machine as shown in Figure 4.6. The load range is selected such that specimen failure occurred within its range. The results are noted in terms of force in Newton and extension is measured in mm. Because of the mechanical sensitivity of the geomembranes to the ambient atmosphere, all the tests are carried out in controlled environment.



Figure 4.6 Tensile compression machine for tensile and seam tests.

4.11.3.2 Strip Tensile Test

This is the same test as described above. The only difference is the specimen shape. This test contains the “Strip” specimen shape. The specimen is rectangular measuring a height of 120 mm between the clamping jaws and having a constant width 25 mm strip. For the strip tensile test the procedure is the same as described in Dumbbell tensile test. This test can be performed on the simple tensile testing machine as shown in Figure 4.3 or on Tension Compression machine following the

test standard ASTM D 882 as shown in Figure 4.6. The test parameters required by Tension Compression Machine are given in Table 4.7.

Table 4.7 Different test perimeters using tension-compression machine.

Sr. No	Test	Standard	Sample Shape	Velocity (mm/min)	Jaws separation (mm)
1	Tensile strength test	ASTM D 638	Dumbbell	50	25
2	Tensile strength test	ASTM D 882	25 mm Strip	50	25
3	Shear test	ASTM D 882	25 mm Strip	50	25
4	Peel test	ASTM D 882	25 mm Strip	50	25
5	Tear resistance test	ASTM D1004	Die-C	50	25
6	Puncture test (tapered probe)	FTMS 101C-2065.1	100 mm dia	500	*
<i>Continued Table 4.7 Different test perimeters using tension-compression machine.</i>					
7	Puncture test (8 mm cylinder probe)	ASTMD 4833	230 mm dia	300	*
8	Puncture Test (pyramid over water)	ASTMD 5494 (Method A)	Pointed	50	*
9	Puncture Test (over Aluminum)	ASTMD 5494 (Method B)	Pointed	1	*

* Test required no initial gauge length or jaw separation

4.11.4 Seams of Geomembrane

Jointing of the two geomembranes materials by overlapping is called seam. In FESS canal lining project three methods were used to joint geomembranes together. These methods are;

- Double wedge welding,
- Extrusion welding, and
- Hot air welding

a) Double wedge welding

The main joint welds are carried out in one procedure by means of an automatic welding machine, which heats the overlapped welding surfaces to the desired temperature and then applied contact pressure to form seams. As the name suggests two welds are made with an open channel between them. This allows air pressure testing of the weld to take place. Average temperature is approximately 350 to 375 C° but differs according to the material formulation.

b) Extrusion welding

The procedure for extrusion welds, which are used for detail and remedial work is that the welding area is pre-heated and compatible welding wire is extruded over the over lapped material. The necessary contact pressure comes from the weight of the hand welding unit itself.

c) Hot air welding

Heated air from an electrical element is blown between the two sheets to be bonded together in order to melt an interface strip from each sheet using an air blower. The average temperature of the heated air is 375 C°. pressure is applied by hand operated rollers.

4.11.4.1 Testing of the weld joints (Seams)

Seams or joints are tested by two types of the test methods as,

- Non-destructive tests, and
- Destructive tests

4.11.4.1.1 Non destructive seam tests

A non-destructive seam test is defined as a test performed in a plant or in a field on a continuous seam without neither destroying nor altering the seam itself. The purpose of the non-destructive tests is to check the continuity of seams. It does not provide information on seam strength. Two methods for testing of the non-destructive seams were used in FESS project.

a) Pressurized dual seam technique (air pressure test)

This test method establishes an air pressure in the channel of a double weld seam. The seam is sealed at two locations and a needle, connected to a pressure gauge and

air supply, is inserted into the channel between the weld areas. A 200 kpa pressure is applied and a pressure is monitored for a certain time. For a satisfactory weld, the air pressure should not change by more than 10% of its initial value over 5 minutes. If pressure drop by 10% locate the faulty area, repair the leak and retest. (See Figure 4.7)



Figure 4.7 Pressurized dual seam technique (air pressure test)

b) Vacuum chamber technique

This test is performed by applying a vacuum to a soaped section of a seam. The vacuum is applied through a chamber equipped with a vacuum gauge, a clear glass view panel in the top and a soft rubber gasket attached to the bottom, a vacuum set between 122 and 244 mm of mercury is applied inside the chamber by use of vacuum pump. Any unbounded area the width of a weld can be detected by observing the formation of bubbles in the chamber. All areas where soap bubbles appear are marked and repaired again. This method tests only a small area at a time, but is very useful for testing patches.

4.11.4.1.2 Destructive Seam Tests

Destructive seam tests are performed at random selected locations. The purpose of these tests is to check that welds or seams are fully integrated with each other or not. Destructive testing involves two techniques, which are

- a) Shear testing, and
- b) Peel testing

a) Shear test on joint

Shear strength testing is performed by applying a force across the seam in a direction parallel to the plane of the bond, subjecting the bond interface to a shearing force. In other words shear testing applied a tensile stress from the top sheet through the weld and into the bottom sheet as shown in Figure 4.7. The shear test is standardized by ASTM D 882 for field seams. (ASTM, 1995)

The specimen are strip having a width of 25 mm (0.98 inches), the initial jaw separation for all types of geomembranes is fixed to 50 mm (1.97 inches) and the jaw separation rate is 50 mm/min. The test results are related to the width of the specimen and not to the cross section.

b) Peel test on joint

To complement the tensile resistance of a seam, a peel test is used to evaluate the adhesion strength between the welded geomembranes. In other words, peel the top sheet back against the overlapped edge of the bottom sheet in order to observe how separation occurs. The peel test indicates whether or not the sheets are continuously and homogeneously connected through the seam.

In destructive tensile testing to ASTM D 882, samples cut of (25 mm strips) are across a seam at right angles and tested on the tensile testing machine. The procedure is the same as above except that the sample is clamped so as to place the seam in peel instead of in shear. The test results are related to the width of the specimen and not to the cross section.

5. CONSTRUCTION ASPECTS OF CANAL LININGS

Canal lining can be carried out with different materials/types, specifications and construction methods. However, a little work on suitability of different lining materials/types and construction methodologies for conditions in Pakistan has been carried out. In order to provide definite recommendation about the use of different materials/types for canal lining with respect to the parameters like effectiveness towards seepage control, life expectancy, construction techniques and economic viability etc, it was considered important to experiment with various lining innovations under FESS canal lining programme. This chapter is especially addressed to the design and construction aspects of the lining works which have been done in the FESS project.

5.1 Design Considerations

Most of the channels selected for lining have discharge less than 2.85 m³/sec (100 cusecs). Seepage reduction was expected to be achieved through lining of the channels with geomembrane placed on a compacted sub-grade and protected by insitu concrete/pre-stress concrete blocks with or without water tight joints.

Analysis of discharges in the existing canal system suggested that the discharge measurement data were more reliable and consistent as compared to the discharges calculated by the adopted formula (Mott Macdonald; 1995). Therefore, it was proposed that for the design of the new lined channels, the existing measured head regulated discharges may be adopted. For the purpose of hydraulic design, the Manning's "n" value of 0.015 was used in the design of lining channels considering the long term effects of water and sediments on the lining. Minimum velocity and slope requirements were established keeping in the view of Lacey's sediment regime. To ensure the optimum velocity at a given discharge and slope and to provide

sufficient head at the tail of the canals, the breadth and depth (B/D) ratio was maintained between 3 to 4 for the channels with discharge greater than 1.42 cms (50 cfs). But for smaller channels with discharge less than 1.42 m³/sec (50 cfs), the B/D ratio was gradually reduced to 1.5.

The design of channels included an additional 20% capacity within lined section to accommodate storage of water accumulating due to sudden closure of outlets and rainfall etc. Lined free board of 125 mm (6 inch) was provided for all channel sections with less than 600 mm (2 ft) depth of flow. For more than 600 mm (2 ft) depth, a line free board of 300 mm (1 ft) was provided. Further, unlined freeboard of 300 mm (1 ft) was provided in all lined channels. Side slope of 1.5 horizontal to 1.0 vertical was maintained in general for insitu concrete lining. However, for small channels having bed width of 1 ft the side slope of 1:1 was maintained. Side slope of 1:1 for all bed widths for the channels with precast panel sections was adopted.

5.1.1 Canal lining criteria

Primary objective of the lining under the project was to reduce seepage losses thereby reducing the subsurface drainage and to increase the equality of water distribution. In addition to the production lining, an experimental lining was also done to test the limits of bold and innovative designs in search for cheaper and quicker ways of achieving seepage reduction and also better design to be adopted for future projects. Relatively short lengths of reaches were lined with different combinations of lining materials. Appropriate monitoring arrangements are made to find out seepage losses before and after the lining in place. It is expected that after a few years some of the lining may fail or seepage losses may increase.

5.1.2 Design options for lining

Canal lining includes not just a barrier with high degree of water tightness, but a composite system comprising most or all of the following elements as,

- a) Sub-grade i.e. soil or other material or structure behind the lining,

- b) Protective layer to prevent puncturing of the impermeable layer from the sub-grade side,
- c) Impermeable layer or liner, and
- d) One or two protective layers to prevent puncturing of impermeable layer from the water table.

The reason for the two protective layers is that, if the main one is concrete, an intermediate protective layer such as geotextile may be needed to protect the impermeable layer during the placing of the concrete. If the concrete is placed in-situ, such a layer may also perform the function of preventing the wet concrete from slipping down the sloping sides of a canal.

5.1.3 Type of concrete

The main types of concrete used as an impermeable layer or as a protective layer in canal lining are in situ concrete or precast concrete. Both kinds can be plain cement concrete or ordinary reinforced concrete using steel mesh or bar. Most of the canal lining used unreinforced concrete. Usually some joints are constructed as expansion joints to allow for subsequent expansion of the concrete while lining. The joints are constructed with compressible filler 10 to 20 mm thick between adjacent panels. Construction joints are either not treated at all or treated with a layer of bitumen or other joint material painted on edges of the first set of panels before the second set is poured.

5.1.4 Joint sealants

Joint sealants are usually used to fill the construction as well as expansion joints for either type of in-situ or precast concrete lining. The purpose is to make the joint water tight to accommodate relevant movements between the sides of the joint without damage or leakage and to prevent the joint from becoming filled with incompressible or rigid material which would render the concrete layer incapable of surviving thermal expansion.

5.1.5 Types of joints sealants

Following types of joints sealants are used for sealing joints in canals.

- a) Bitumen with sand or sawdust,
- b) Hot poured rubber bitumen compound,
- c) Bituminous putty, or
- d) Elastomeric compound.

Type “a” is not usually recommended. The other types are good for most purposes. The joint sealant used for the project`s lining works were hot poured rubber/bitumen compound for horizontal joints and a bituminous putty for sloping, vertical and soffit joints unless otherwise shown.

5.2 Geomembranes for lining

A sheet of flexible material known as geomembrane, typically 0.2 to 3 mm thick is used for canal lining. There are many materials and alloys of various types used for geomembrane. Mostly these materials are polymers formed by the chemical combination of monomers. These materials can be further distinguished as elastomers (rubbers) and thermoplastic materials. Another useful distinction can be made within the thermoplastic materials. i.e. polyolefins like varieties of polypropylenes and polyethylenes and non-polyolefins like PVC (Polyvinyl chloride). Polyolefin contain carbons and hydrogen only and are chemically inert so that seams can be made by heat (welding methods) only. Non-polyolefins are chemically reactive to extent that solvents can be used for seaming. Elastomers can also be joined by solvents/adhesives. Properties of various geomembranes differ widely between types according to their chemical composition, (Koerner, 1990). The properties of geomembrane can be measured by standard tests (Rollin and Rigo 1991). Only those geomembranes are used for lining that withstand the puncturing, tearing aging and ultraviolet radiation. These properties are tested in Engineer`s Geosynthetics Laboratory.

5.2.1 Seams and joints

All seams or joint joining formerly separate pieces of geomembrane shall be classified as either factory seams or field seams. They are classified as,

- A factory seam is a joint or seam made in an enclosed space such as a factory, with a controlled environment to protect the materials and equipment from excessive dust, wind, moisture or radiation (windows, doors and other wall or roof opening shall not exceed 5 percent of floor area), and
- Any other seam is field seam.

The geomembrane shall be made into large pieces under factory condition, using factory seams unless the piece has no seam. These pieces whether rolled or folded, shall be brought to site with sufficient protection during transport and storage to avoid damage to the geomembrane, and spread in the canal before being joined to each other or to rigid structures. Field seams shall only be used approximately at right angle (90 degree) to the center line, never longitudinally, except for short local seams near structures.

5.3 Locations and details of experimental lining

The locations of the experimental linings are shown in Table A.1 which gives the locations of the particular experimental canal reaches constructed 1996-2001 under the contracts alongside the much larger quantity of production lining.

- a) The experimental reaches for design discharge Q up to $2.83 \text{ m}^3/\text{sec}$ (100 cfs), comprising all hard surface lining except Type I , arranged in order of location,
- b) The same reaches are arranged by lining type for convenient reference and using bold type for the basic lining types, and
- c) The experimental reaches on 3R-Hakra, which carry discharge more than $2.83 \text{ m}^3/\text{sec}$ (100 cfs) about $11.3 \text{ m}^3/\text{sec}$ (400 cfs), comprising lining type B and its variants C, D, G and H, as well as type A and I.

The details shown in the Table A.1, especially reduced distances, are as precise as was possible in January 1999. At the end of the contracts small changes is made to

the nominal chainage of some experimental reaches, and perhaps some other details, but these changes will not be of any practical significance for this research.

5.3.1 Design specification for experimental reaches

Following are the design specifications for experimental reaches,

- The experimental reaches were designed for Manning’s values of 0.015 for concrete surfaces with relatively widely spaced joints (Type 5 and Type 2), 0.017 for types using precast slabs (Type 9 and variants), and 0.016 for the “parabolic” channels of Type 4,
- The three sizes of the parabolic channel were designed as given. The depth of the channels also includes freeboard (at least 0.5 ft) (Table 5.2). These were arranged to suit the set of reaches intended to be lined with parabolic sections at the time the design was done (January 1997), with each size spanning a 1.5 to 1.6 fold range of conveyances. These three sizes were part of a possible wider set with a channel top width of over 1.52 m (5 ft) would be difficult to handle, and
- To avoid many different sizes of precasting moulds, the Type-2 reaches were confined to those that could be conveniently covered by two depths. The smaller with a water depth of 68 cm (2.25 ft) and a free board of 15 cm (0.5 ft), and the larger one with 90 cm (3 ft) and 30 cm (1.0 ft) making a total channel depth of 120 cm (4 ft) for all the trapezoidal lining types (Types 5b, 5c, 9, 6 and their variants) the freeboard was designed as 15 cm (0.5ft) for water depths of less than 60 cm (2 ft) and otherwise 30 cm (1 ft). This being the agreement reached at the design stage for the production lining.

Table 5.1 Parabolic channels under experimental lining

Channel size	Top width	Depth	Typical Q
	(m)	(m)	(cms)
Small	1.02	0.68	1.0-1.5
Medium	1.16	0.77	1.5-2.1
Large	1.35	0.90	2.0-3.0

5.4 Field Experiments on Canal Lining

5.4.1 Constructional aspects

The experiments were aimed at finding more cost effective ways of lining existing canals in the future, primarily to reduce water loss by seepage, under typical Punjab conditions and with special emphasis on methods that could be used without diversion channels. The experimental linings are intended to explore ways of lining canals more effectively or more cheaply in the future than is possible now. This experimental plan was designed in 1995-96 (Mott Macdonald, 1995).

5.4.2 Nature of the canals lined

The existing canals of the FESS area are alluvial canals typical of irrigation schemes in the flatter parts of Punjab. The range of sizes tested here extended from small canals about 1.83 m (6 ft) wide and carrying 0.11 m³/sec (4 cfs) to larger ones about 18.28 m (60 ft) wide and carrying discharge about 11.32 m³/sec (400 cfs). Their longitudinal slopes vary generally from 1 in 10,000 to 1 in 2,000, the larger canals usually having the flatter slopes. Mostly the experiments were done in canal reaches carrying discharge less than 2.83 m³/sec (100 cfs), but some were done in one particular canal reaches carrying discharge about 11.32 m³/sec (400 cfs). (Figure 5.1).

5.4.3 Basic Canal Lining Types

Under experimental component, the different lining types are used using different combination of geomembrane and geotextile with hard and soil cover. Its objective was to search for more cost effective ways of canal lining in existing canals in future. One way to make lining more cost-effective is to make it cheaper without undue loss of effectiveness and one of the main costs, both in direct financial terms and in terms of disruption to other activities, is the use of diversion channels.

All the experimental lining types in canals carrying less than 2.83 m³/sec 100 cfs were carried out using a relatively thin but good quality geomembrane namely a

Flexible Polypropylene alloy (FPA) manufactured by the blown film technique in a thickness of 0.5 mm and a roll width of about 19 feet and welded where necessary by the double wedge method or by extrusion welding. This was in contrast to production lining component and the experiment in large canal, where mostly used a very low density Polyethylene (VLDPE), 0.75 mm thick and made in slightly wider rolls

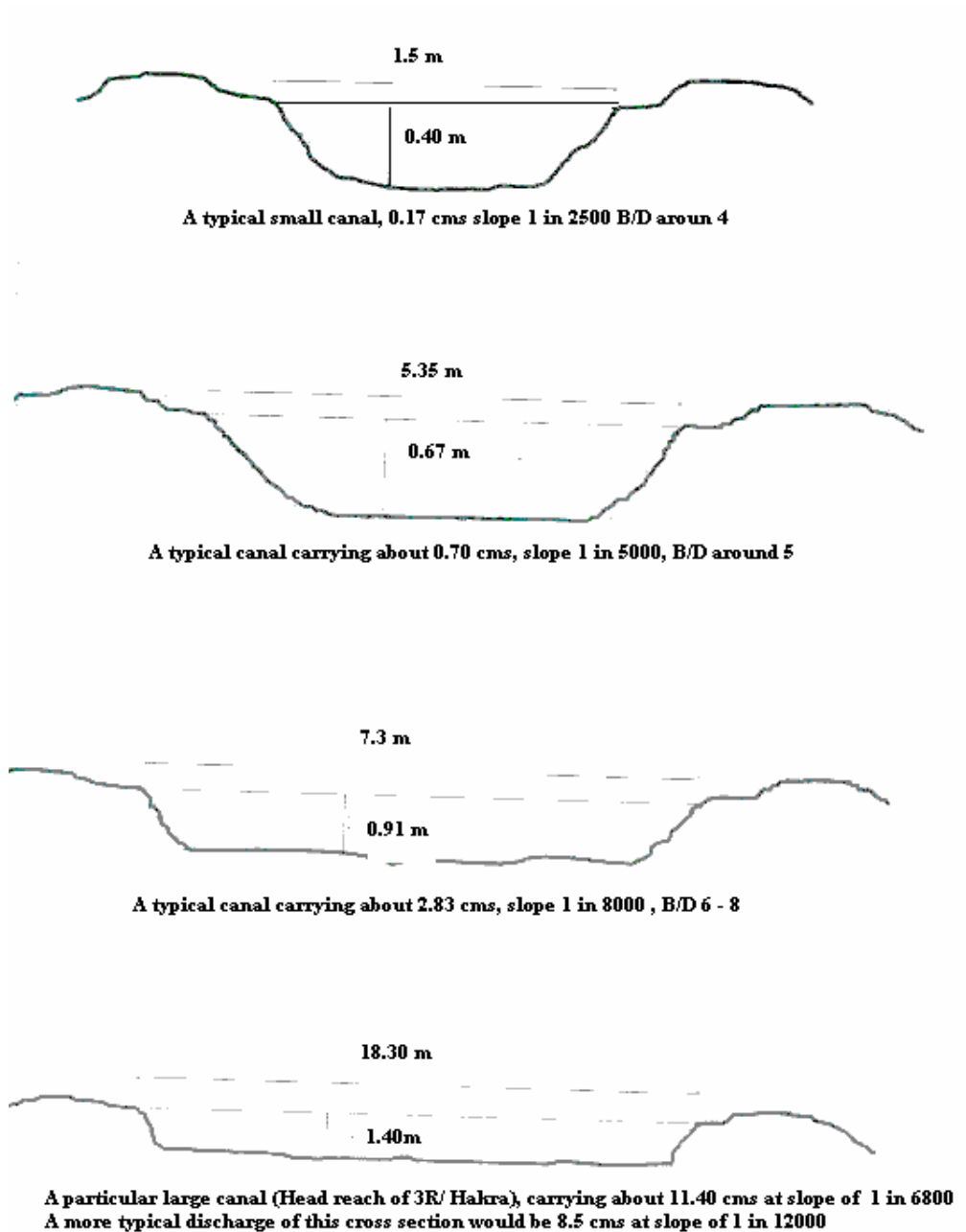

Figure 5.1 Typical shapes of unlined canals in project area

5.4.3.1 Geomembrane under Soil Cover

This group of lining types can be used in practice only for canals deep enough to prevent contact between buffalo hooves and the canal bed when the canal is full, i.e., deeper than 1.22 m (4 ft) and even then only with special precautions near the banks where wallowing buffaloes will always have access. On the bed geomembrane needs to be covered with soil (normally the fine sand which collects on canal beds anyway) cover to sufficient nominal or design depth to protect it in the long term from occasional traffic and buffaloes during annual closures, from people who extract sand for construction purposes during closures and from future changes in the bed level due to hydraulic and sediment transport condition. Experiment includes design sand cover depth of 0.30, 0.45 and 0.61m (1, 1.5 and 2 ft). There are two basic types in this group.

Type A: Geomembrane on the bed and in the bank, where geomembrane in the bank is protected by geotextile and several feet thickness of compacted cohesive soil. (Figure 5.2)

Type B: Geomembrane on the bed only, under sand cover no geotextile (Figure 5.3)

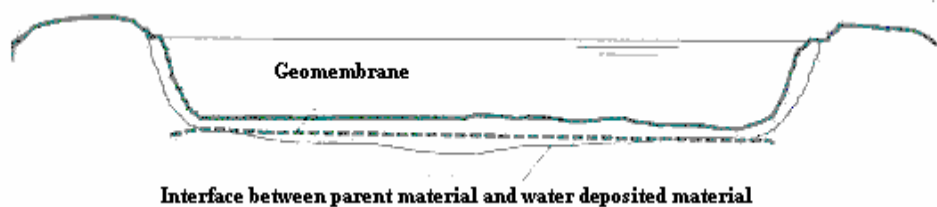

Figure 5.2 Geomembrane on the bed and banks and protected by geotextile



Figure 5.3 Geomembrane on the bed only under soil cover with no geotextile

5.4.3.2 Geomembrane under Hard Cover

The smaller canals are so shallow 0.4 to 1.22 m (roughly 1.3 to 4 ft) water depth) that it is not realistic to expect a soil cover to survive as effective protection to a geomembrane layer, primary because of wallowing buffaloes. Therefore, a hard cover is needed if a geomembrane is to be used, and in this group the experiments consisted of trails of various sorts of hard cover, plus a few lining types with no geomembrane and the water tightness is provided by making well sealed joints in the hard cover. In canals carrying discharge less than 2.83 m³/sec (100 cfs), most of the experiments involved a geomembrane as the watertight element with concrete cover to protect it from damage, but some variants have no geomembrane and one has bricks lining instead of concrete. In some variants the geotextile is provided between geomembrane and concrete, to protect the geomembrane during construction and or to prevent wet concrete sliding on slopes. Seven basic lining types were tested, five of them involving precast concrete (Some concrete joints have no sealants). The details are provided as follows, (Table 5.2, Figure 5.4 to 5.17)

Table 5.2 Seven basic types of experimental lining

Sr. No.	Lining Types	Description
1	Type I	Concrete filled fabric mattress over geomembrane, no geotextile Tested in 11.33 cms (400 cfs) canal, Figure 5.4.
2	Type 5b	Trapezoidal section, 75 mm (3 inches) in-situ concrete with sealed joints, no geomembrane or geotextile, Figure 5.5.
3	Type 5c	Trapezoidal section, 75 mm (3 inches) in-situ concrete over geomembrane (Like the production lining, Figure 5.6)
4	Type 9	Trapezoidal section, 50 mm (2 inches) precast concrete over geomembrane (Figure 5.7)
5	Type 6	Trapezoidal section, 115 mm (4-1/2 inches) mortared brick layer over geomembrane, no geotextile (Figure 5.8)
6	Type 2b	50 mm (2 inches) insitu concrete on bed, vertical precast units at sides, both over geomembrane (Figure 5.9)
7	Type 4g	Parabolic precast concrete units over geomembrane (Figure 5.10)

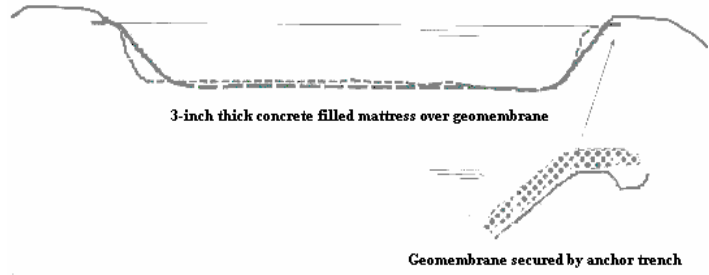

Figure 5.4 Geomembrane under mattress filled by concrete

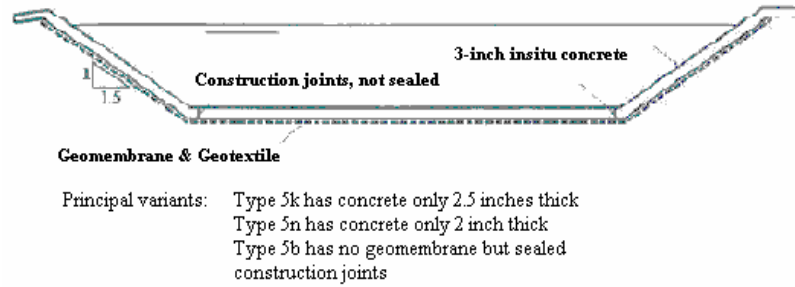

Figure 5.5 In-situ concrete over geomembrane

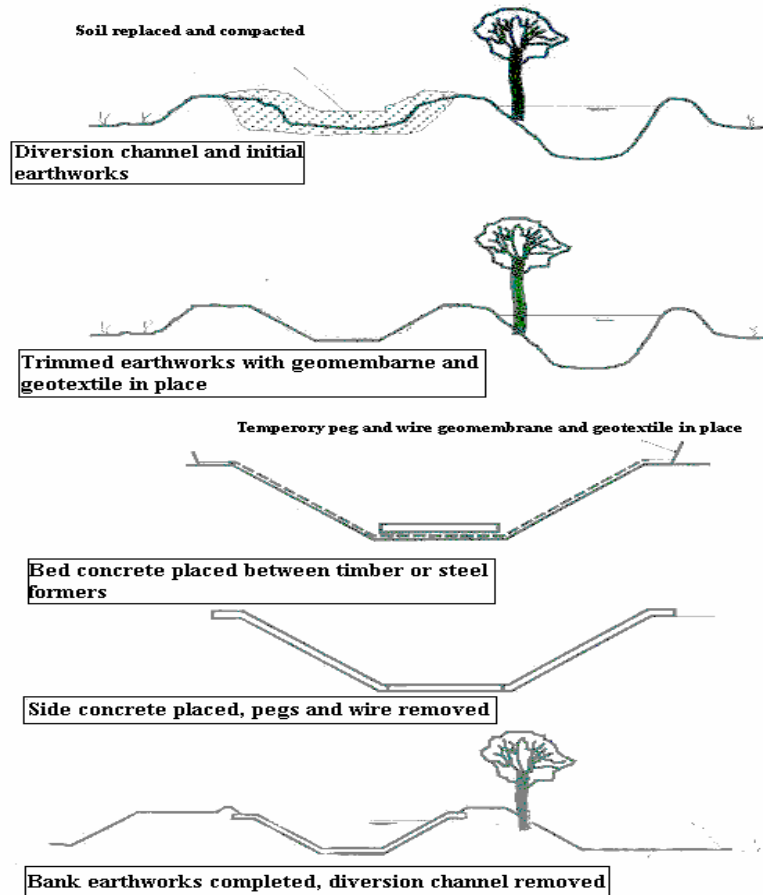

Figure 5.6 Construction sequence for in-situ concrete over geomembrane

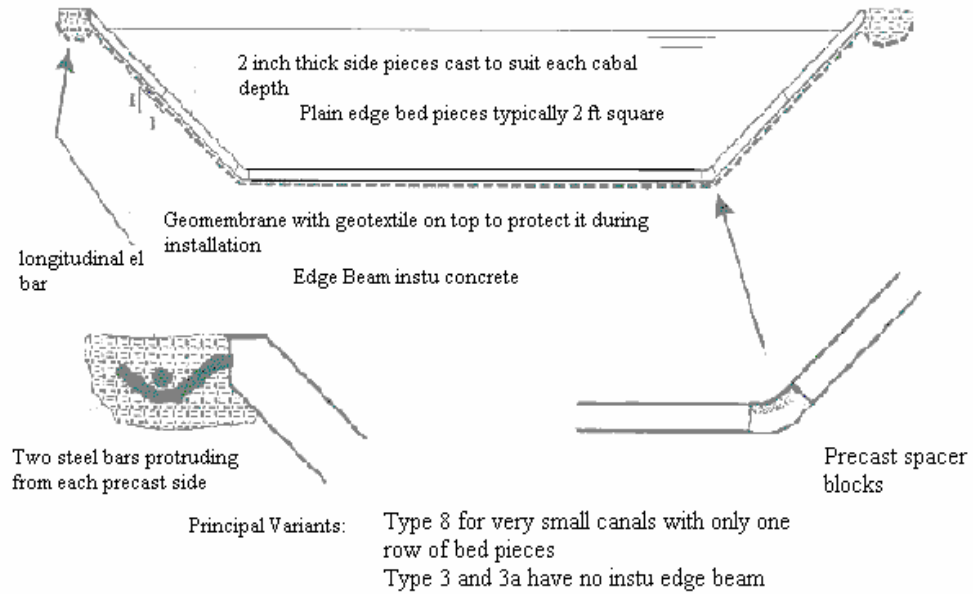

Figure 5.7 Precast concrete over geomembrane

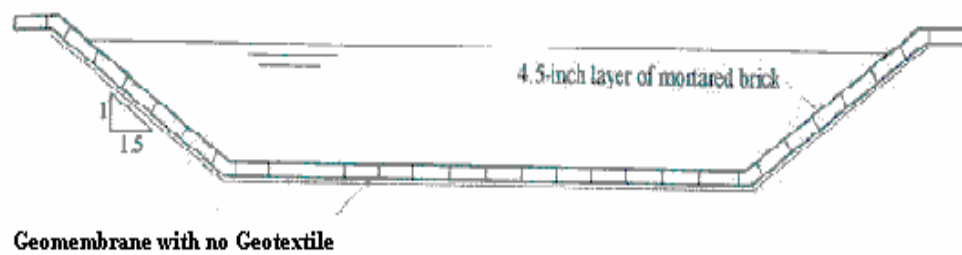

Figure 5.8 Bricks in mortar over geomembrane

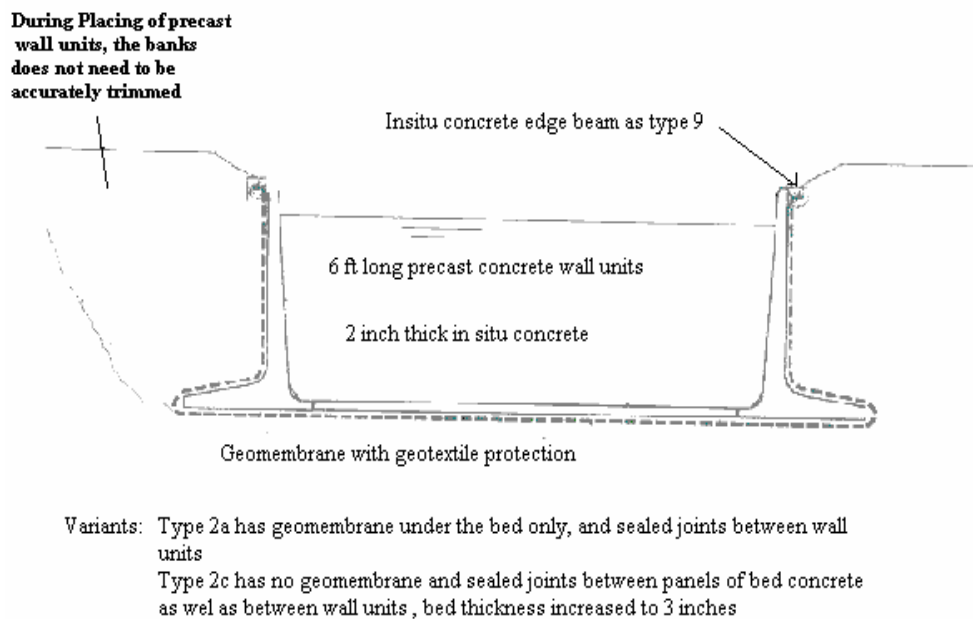
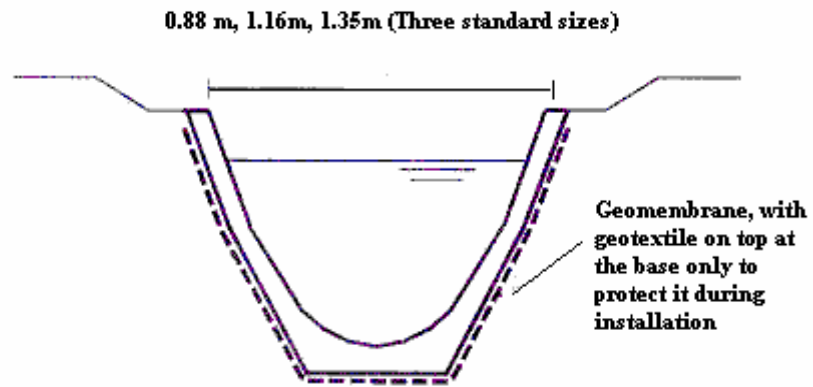

Figure 5.9 Vertical precast walls with insitu concrete in the bed both over geomembrane



Variants: Types 4sg, 4mg and 4lg are the three sizes with geomembrane, they have plain butt joints between pieces with are 60 cm to 120 cm long;

Types 4s, 4m and 4l have no geomembrane, the joints between the pieces being spigot-and socket joints with sealant, thus:



Figure 5.10 Parabolic precast concrete units over geomembrane



Figure 5.11 Excavation of natural canals to give trapezoid shape.



Figure 5.12 Trimming of trapezoidal section to proper shape.



Figure 5.13 Placing of geomembrane before lining.



Figure 5.14 Placing of hard cover (in-situ concrete)



Figure 5.15 Finished form of lined concrete.



Figure 5.16 Anchoring of geomembrane on the banks before placing of precast units



Figure 5.17 Placing of precast units in the canal section

5.4.3.3 Variants of the Experimental Lining Types in FESS Project

Following are the variants extracted from the above seven types of lining has been tried in FESS project under experimental programme. Onward pre-lining and post-lining seepage tests have also been performed on these lining. The seepage results have been discussed in the coming chapters. Table 5.3 shows the details of the variants used in the experimental component.

Table 5.3 Variants of the experimental lining types

Type	Description
	<i>A:-Lining type with hard cover</i>
1a	Tongued and grooved slabs with geomembrane, geotextile and joint sealant
1b	Tongued and grooved slabs with geomembrane geotextile and no joint sealant
1c	Tongued and grooved slabs with geomembrane, joint sealant and no textile
2a	T-shaped precast walls with in-situ concrete on bed overlain geomembrane on bed with sealed joints, with geotextile precast walls, 50.4 mm (2 inch) in-situ bed without bed joints walls and bed only.
2at	T-shaped precast walls with in-situ concrete on bed overlain geomembrane on bed with sealed joints, with geotextile precast walls, 50.4mm (2 inch) in-situ bed without bed joints walls and bed.
2ax	T-shaped precast walls with in-situ concrete on bed overlain geomembrane on bed with sealed joints, with no geotextile precast walls, 50.4mm (2 inch) in-situ bed without joints walls only.
2b	T-shaped precast walls with 50.4mm (2 inch) in-situ concrete on bed without joints sealed with geomembrane and geotextile.
2c	T-shaped precast walls with 50.4mm (2 inch) in-situ concrete on bed with joints walls and bed without geomembrane and geotextile
3a	Precast, 50 mm (2 inch) plain slabs, mortar joints $Q < 0.28 \text{ m}^3/\text{sec}$ ($Q < 10 \text{ cfs}$) without joints sealed with geomembrane and no textile.
3b	Precast, 50 mm (2 inch) plain slabs, mortar joints $Q < 0.28 \text{ m}^3/\text{sec}$ ($Q < 10 \text{ cfs}$) without joints sealed with geomembrane and textile.
4s	Parabolic, with joints sealed not geomembrane and geotextile
4L	Parabolic, with joints sealed not geomembrane and textile on a large canal
4lg	Parabolic, without joints sealed, with geomembrane and geotextile on a large canal
5a	76.2mm (3 inch) in-situ concrete with joints sealed, with geomembrane and geotextile original modification of production lining.
5b	76 mm (3 inch) in-situ concrete with joints sealed, with no geomembrane and geotextile original modification of production lining.

<i>Continued Table 5.3 Variants of the experimental lining types</i>	
5c	76 mm (3 inch) insitu concrete without joints sealed, with geomembrane and geotextile original modification of production lining.
5k	63.5 mm (2.5 inch) insitu concrete without joints sealed and with normal geomembrane and geotextile.
5n	50 mm (2 inch) insitu concrete without joints sealed and with normal geomembrane and geotextile.
5cd	76 mm (3 inch) insitu concrete without joints sealed and with textured geomembrane and no geotextile.
5kd	63.5 mm (2.5 inch) insitu concrete without joints sealed and with textured geomembrane and no geotextile.
5nt	50 mm (2 inch) insitu concrete without joints sealed and with textured geomembrane and no geotextile.
6	Bricks in mortar without joints sealed geomembrane and no geotextile
7	Tongued and grooved precast slabs of 914 mm (3 ft) bed in one piece without joints sealed and with geomembrane and geotextile.
8	Tongued and grooved precast, 50.4 mm (2 inch), slabs of 914 mm (3 ft) bed in one piece in smaller canals without joints sealed and with geomembrane and geotextile but with in-situ edge beam.
9	Tongued and grooved precast, 50 mm (2 inch), slabs of 914 mm (3 ft) bed in one piece with in-situ edge beam in larger canals without joints sealed and with geomembrane and geotextile.
Op3	Mattress filled with concrete minimum thickness 76 mm (3 inch) concrete cover, without joint sealed and with geomembrane and geotextile.
<i>B:-Lining types with soil cover</i>	
Op1	457 mm (1`-6”)thick soil cover with geomembrane on bed only no geotextile and joint sealant
Op2	609 mm (2 ft)thick soil cover with geomembrane on bed only no geotextile and joint sealant

5.4.3.4 Comments on the Experimental Programme

The seven basic lining types and their variants bring the number of combinations tested to twenty nine. Table 5.3 lists all of them and summaries their key characteristics. Some types included in the list of basic types were only developed towards the end of the programme, in the light of experience with other types which are now treated as variants. For the sake of clarity the above description follows as logical rather than a historical order. For instance, Types 1b and 3 were included from start, and after more than a year Type 9 was developed to exploit the best

features of both the earlier ones. The experimental reaches range from 14.63 m (48 ft) to several hundred meters in length, and total length sum to 32 km.

The experimental lining programme deliberately included some innovative and untried lining methods, and it was expected at the planning stage that some of them would fail. In the event some types proved unsuccessfully or impractical, at least under local physical conditions, and some others were not successful under the prevailing contractual arrangements and scale although they might still have potential in other contractual circumstances; for instance, in a large enough project to use modern precasting methods. Some methods proved successful and could be recommended for future projects wherever they would be appropriate to the circumstances

5.5 Results of Experiments

5.5.1 Aspects and Criteria

There are four main aspects under which lining types are judged as,

- Ease of construction,
- Water tightness (likelihood of achieving good water tightness at the time of construction),
- Durability (likelihood of maintaining initial degree of water tightness in the long term), and
- Relative cost.

The basic lining types tested and their variants are discussed in respect of the above criteria. The assessment also uses the pre and post lining seepage measurements where they are available. In many cases, this is based on subjective and on observations supported by discussion with contractors and consultant's staff and others. The comparison is primary in terms of conditions in the FESS area, but some remarks on likely performance under other conditions are also included in this paper.

5.5.2 Summary of Experimental Results

The conclusions are based on observation of the lining trials conducted on FESS lining project, but are extended by some reference to experience elsewhere and by

some informed speculation about what would happen if particular lining types were used on a larger scale or with other contractual arrangements. (Table A.2)

5.6 Relative Costs of Lining Types

5.6.1 Standard Canal Sizes

Two systematic cost comparisons have been made for the more promising lining types, one for canal discharge up to 2.83 m³/sec (100 cfs), and a separate one for larger canals lined without diversion channels. Four general ranges were chosen for comparison, with typical discharges of 0.25, 0.85, 2.8 and 9.4 m³/sec (9, 30, 100 and 333 cfs). Table A.3 gives the key parameters defining the four standard sizes.

These standard shapes have not been systematically optimized for each lining type, so it is probable that some types could be made slightly more cost effective for some canal sizes by fine-tuning the width/depth ratio, but they are reasonable shapes for the purposes of the cost comparison. In the case of Type 2 the standard wall heights used in the actual lining project were used, because cost information is available for those sizes and because they fit the 0.85 m³/sec (30 cfs) and 2.83 m³/sec (100 cfs) cases quite well: Type 2 is not applied to the smallest size because it would probably have no advantages for such small canals. The criteria for canal side slopes and Manning's n are the same as used in the actual project: Trapezoidal canals have 1 in 1.5 side slopes except for the precast slabs (Type-9 has 1:1), the near vertical was of Type-2, most of the Types in the 333 cfs case, and Type-5 when shallower than 0.60 m (2 ft). Minimum lining freeboard (not shown in the table) was also assumed as in the lining project: 15 cm (0.5 ft) for water table less than 60 cm (2 ft) and for Type-2 up to 70 cm (2.3 ft) otherwise 30 cm (1.0 ft) except for the special treatment of Type-A (whose geomembrane edges, deep in the banks, only have to extend 15 cm (0.5 ft) above nominal water level). It is also to mention here that these are the lining freeboard; the earthen banks provide additional freeboard in all cases.

5.6.2 Relative Costs for Discharges up to 2.83 cms (100 cfs)

This group of canal sizes represents canals shallow enough for any geomembrane on the bed to need a hard covering to protect it from mechanical damage, such as the hooves of buffaloes. The lining types covered in the cost comparisons for discharges up to 2.83 m³/sec (100 cfs) are as follows and detailed in Table A.4;

- Type 6: Mortared brickwork over geomembrane, with a diversion channel,
- Type 5c: Geomembrane and geotextile under in-situ concrete, with a diversion channel,
- Type 5b: Insitu concrete with sealed joints, no geomembrane, with a diversion channel,
- Type 5n: Like Type-5c but with 50 mm (2 inches) instead of 76 mm (3 inches) thickness of insitu concrete,
- Type 9: 50 mm (2 inch) plain precast slabs over geomembrane and geotextile, with a diversion channels,
- Type 9: The same as above but without diversion channel,
- Type 9: With a diversion channel but without any geotextile protecting the geomembrane,
- Type 2b: Geomembrane and geotextile under vertical precast walls and insitu bed, with diversion channel,
- Type 2b: The same as above but without diversion channel,
- Type 2at: Vertical precast walls with sealed joints, geomembrane under insitu concrete on bed only, with a diversion channel; vertical precast walls with sealed joints, geomembrane and geotextile under in situ concrete on bed only, with a diversion channel, and
- Type 2c: Vertical precast walls and insitu concrete bed, all with sealed joints, no geomembrane, with diversion channel.

The comparison used carefully considered units costs, based on the 1995 contracts for the actual lining projects but updated to 1999-2000 prices and quite extensively modified where those contracts had inappropriate rates against particular items. The results remain approximate, since the real relative prices of different sorts of

construction, like concrete, earthwork, and geosynthetics, depend on the local conditions (for instance; distance to aggregate sources) and a contractor policy at the time of tendering. The cost assumes some adjustments to the specifications in the light of the experience of the last four years on the production and experimental lining. In particular cases the rates for diversion channels have been estimated as in contracts have unrealistically low rates.

The comparison indicates that the brick covering costs almost the same as the in-situ concrete, at the rates assumed here [including a rate of 0.12 cents (Rupees 5.4) brick at 1999 prices, including mortar and placing]; about 47 % of the cost is in the brickwork.

For the geomembrane lining under insitu concrete, Type-5c, against which the others are compared, the dominant cost elements are the concrete (37%) and the geosynthetics (34%): The diversion is estimated to cost only around 15% of the total. The conventional concrete lining without geomembrane, Type-5b, is only 6 to 20% cheaper than Type-5c, which must be considered its lesser weight tightness and longevity. The figures for Type-5n show that Type- 5c could be made about 10 % cheaper by reducing the thickness of the concrete layer.

The simple precast slab option, represented by Type-9, is estimated to be slightly more expensive than Type-5c if diversion is used for both, but if precast lining can be installed quickly enough without a diversion it becomes cheaper for the medium and larger sized. Omitting the geotextile from Type-9 would save about 8% more. The concrete costs more than geosynthetics in all these lining types.

The lining types using near vertical precast wall units and insitu bed concrete, Type-2b and its variants, cost much more than the other types, largely because of the reinforcing steel in the wall units which is estimated to cost about USD 52.48 (Rupees 2624) per meter in the medium size canal and USD 65.60 (Rupees 3280) per meter in the large one, thus representing 30 to 40 % of the total cost of these lining types (this estimate uses a unit rate of about USD 0.90 (Rupees 45) per kg for steel, in place, which is derived from the lining contracts: in any future large scale use of this type, design refinements might reduce the steel cost)

5.6.3 Relative Costs for Discharge over 2.83 m³/sec (100 cfs)

This separate comparison refers to canals considered deep enough for a geomembrane to survive in the bed without a hard cover: this means roughly a water depth of about 1.4 m (4.5 ft) or more. This comparison is based on the experiments in the 3R-Hakra canal, with its nominal discharge of about 8.49 m³/sec (300 cfs) and its usual real one of about 11.32 m³/sec (400cfs) so as to fit in with the comparison of the smaller canals and the sequence of sizes at discharge ratios 10:3, The lining types under this category are considered as,

- Type-B, the partial lining option with geomembrane in the bed only, under 0.60 m (2 ft) of sand,
- Type-A the bed and sides option with soil cover throughout (although this was not successful in the field trails, it is included in the comparison to help decide if it is worth pursuing further),
- Type-M, the option of using unmortared brick to protect geomembrane on the banks (one of the types discussed but not tested in the field),
- Type-I, the use of concrete filled mattress to protect geomembrane, which was successful in the field but very expensive, and
- Type N, using concrete filled mattress on the banks only, which has been suggested as a way of combining the best features of Types-B and I.

The last two of these involve the specialized fabric mattress suitable for filling with pumped concrete. In the field trials this was done with an imported fabric to a high specification, and once the contractor's teams had mastered the unfamiliar techniques, it worked well. If either of these types were to be used on a large scale in Pakistan or a similar country, it would be worth while to investigate the possibility of relaxing the specification to some extent and or fabricating the mattress locally. This cost comparison considers the possibility in a crude way by means of a sensitivity test where the cost of concrete filled mattress is arbitrarily reduced to 44% of the cost of the imported version as paid in the trails. These are referred to as Type Ia and Na. Of the lining types which hold premise of almost complete water tightness, the hypothetical use of the local fabric for a concrete- filled mattress on the banks only, Type-Na, as well as being the quickest to implement, is the cheapest and is used as a basis for the relative costs in the last line of the Table 5.4. Type-A has almost the

same cost per meter of the canal, but it is difficult to construct, especially when the banks are narrow, and have problems with the stability of the banks.

Still with the local fabric for a mattress, Type-Ia is nearly 40 % more costly than Type-N and is therefore, not attractive. Type-I and N, with imported fabric mattress at the rates applied to the trails on canal 3 R-Hakra are even more expensive. The bed only lining of type-B costs a third of the local fabric type-Na, the cheapest of the full lining types, but it cannot prevent more than 60% of the seepage loss.

Table 5.4 Summary of relative cost of some lining types for canals carrying discharge over 8.49 m³/sec (300 cfs).

<i>Comparison for 9.83 m³/sec (333 cfs) Canal size, without diversion</i>						
Type-B	Type-A	Type-M	Type-I	Type-N	Type-Ia	Type-Na
			Imported Fabric		Local Fabric	
<i>Costs in Rupees per meter of Canal at January 1999 Prices</i>						
2,939	9,187	6727	22,750	14,546	12,218	8,875
<i>Costs in USD per meter of Canal at January 1999 Prices</i>						
58.77	184	138.5	455	291	244.36	177.51
<i>Costs per unit Canal lengths relative to Type Na (which uses local fabric)</i>						
33 %	104 %	78 %	256 %	164 %	138 %	100 %

5.6.4 Costs per Unit Area

The above comparisons between lining types have been done in terms of costs per unit length of certain standard canal sizes, because that it is the only way to make a fair comparison between lining types that have inherently different shapes and hence different lining areas for the same performance. For interest, the typical costs per unit area, relative to the channel surface up to the top of the lining freeboard on each bank but not including any bars, as follows,

- For the 0.26 m³/sec (9 cfs) size, about USD 18 per square meter for Type-5c, and within 12% of that for other types,
- For the 0.85 m³/sec (30 cfs), for the trapezoidal types USD 37 to 41 for Types 2b and only slightly less for its less watertight variants, and
- For the 2.83 m³/sec (100 cfs) size without diversions, USD 11 per square meter for Type Na, but USD 18 for the equivalent (Type N) with imported

fabric; only USD 5 per square meter for the bed only lining of Type B (relative to the bed area).

5.6.5 Overall Cost Comparisons

It must be emphasized that these cost comparisons are very approximate. True relative costs for any future project will depend on its location and scale and on local conditions. This analysis used some unit costs from actual lining contracts, but replaced them with specially developed estimates where the contract rates were seriously unrealistic. The results are considered generally realistic for project conditions.

With these assumptions and unit cost estimates, it appears that for small canals the use of geomembrane is probably justified, since a simple insitu trapezoidal design with a geomembrane (Type 5c) costs only 5 to 25% more than a traditional concrete lining with sealed joints, and is significantly more watertight and durable. In any future lining projects, the relative cost of geomembrane may be less than assumed here, due to technological advances, well informed specifying, and the possible use of locally manufactured or locally extruded geomembrane: this would increase the relative advantage of geomembrane lining types over others.

For larger canals, where geomembrane can be used in the bed without a hard cover, the lining types that protect a geomembrane with hard cover on the banks and sand on the bed are the most promising. The one using unmortared brick on the banks, Type-M, would be relatively cost-effective in the limited conditions that make it feasible, and otherwise Type-N, with concrete filled mattress on the banks, is worth considering, especially if high cost of imported mattress fabric can be avoided. If banks are wide enough and ways can be found to avoid instability in bank fill, then Type-A, with geomembrane under the soil cover only, may be cost effective, possibly cheaper than Type-N. The bed only option, represented by Type-B, is probably the cheapest per unit of seepage water saved, and may be attractive for cases where it is acceptable to prevent only half the seepage.

5.7 Conclusions and Discussions

Table A.5 brings together the conclusions of the technical and cost comparisons between lining types. No single lining type can be recommended for all conditions. Comparison with the conventional insitu concrete lining method (Type 5b) indicates that the use of geomembranes is probably justified. When the need for sealed joints in the conventional lining is taken into account, and their poor long term durability, the simple insitu type with geomembrane (Type-5c, similar to the production lining) is only slightly more costly and considerably better for water tightness and durability. For small canals, this in-situ type with geomembrane is, therefore, favoured. For any lining project of sufficient size to justify modern precasting equipment, the use of plain precast slabs in place of in-situ concrete, as a protection to a geomembrane, is worth considering (Type-9), especially where it can be installed quick enough to make diversion channels unnecessary. The vertical sided hybrid design (Type-2) is too expensive to be attractive, except in special circumstance of restricted width.

For canals deep enough to enable a geomembrane to be buried under sand the bed, without danger of damage by animals, it is worth considering the use of sand cover in the bed and a hard cover on the banks only. The best kind of hard cover is probably a concrete filled mattress (Type-N), preferably using locally manufactured fabric to reduce costs, if the project's scale is big enough. Under special circumstance unmortared brick may be feasible instead (Type-M), which would reduce cost but be difficult and slow to install. On overall basis, taking into account of all criteria in the test table, the three most favourable lining types are as follows,

- Geomembrane under insitu concrete (Type-5c)
- Geomembrane under precast concrete, trapezoidal (Type-9)
- Geomembrane under sand on the bed and mattress on bank (Type-N)

There are some further methods for discussion for canal lining, which for reasons of timing and resource constraints have not been covered in this paper. One development of potential advantage is the use of geosynthetics clay liners (GCLs). A GCL typically comprises of two geotextile layers with a layer of bentonite clay between them. The resulting lining material is laid in a canal with bentonite in unhydrated state, and when it hydrates on contact with canal water it forms a layer of very low permeability. The significant advantage relative to geomembrane is that the

water proof layer is to a considerable extent self sealing after accidental or other damage. Cost and technical feasibility would depend on very markedly on whether a supply of suitable bentonite could be found reasonably near a particular canal lining project. Techniques for rapid installation would need to be developed for a situation like this project, with only one month's closure per year. Another possibility worth considering is the use of synthetic geocells or geogrids to stabilize either soil or concrete used as a protector cover over a geomembrane in a canal lining system. It is recommended that the designer of any future canal lining project should consider these modern products in addition to the more conventional ones covered in this thesis.

6. SEEPAGE INVESTIGATION AND DATA ANALYSIS

6.1 Plan of Seepage Measurements

Seepage rates vary from site to site depending upon varying depth to water tables, relative water level elevations in the channels and different degrees of cut and fill, the soil grain size, its distribution in the bed and on the banks of the test reaches of the channels, in addition to variation in other physical conditions along the lengths of the selected test reaches of the channels. A number of measurements have been made, of the rate at which water is lost from project's canals before lining. During the annual periods of the year, January 1998 and continued through the canal closure periods up to 2000, in overall fifty pre-lining ponding tests and a series of fourteen pre-lining in-outflow tests, each consisting of several replications, have been carried out on selected channels in the project area. The pre-lining channels ponding tests within the project area contained twenty five ponding tests on small channels, mostly with the design flows up to 2.83 m³/sec (100 cusecs) except on 3-R Khattan distributary where maximum flow in the channel ranged up to about 8.49 m³/sec (300 cusecs). The planned seepage experiments was further extended to include two ponding tests on the Malik Branch during the canal closure period December, 1997 - January, 1998 in pursuit of the recommendations based on the review study from the World Bank advisors and the other experts indicating need to acquire relative assessment of water losses leaking through smaller and bigger channels. These tests involved seepage measurements on two isolated segments of this big canal which conveys flow ranging between 32.5 to 42.4 cms (1150 and 1500 cusecs).

6.2 Pre-lining Seepage Measurements

Pre-lining seepage measurements by ponding test method were started in the FESS area on the selected channels during the closure period in January, 1998. Twenty five ponding tests were carried out on unlined canal reaches with water surface widths varying roughly from 1.52 m to 30.48 m (5 to 100 feet) in FESS and besides that 4

ponding tests performed outside FESS. For each ponding test a length of canal, usually 304.8m (1000 ft), was closed off with the two earthen banks, seepage through the banks being minimised by compaction and the use of light geomembranes. The results are indicated in the tabular form in Table A.6 and analysis in graphical forms Figure 6.1 and 6.2. The ponding tests on these channels, (where either canal water or pumped groundwater was used for filling) indicated quite low seepage rates ranging from 37 mm/day (1.41 cfs/million sq. feet) to 79 mm/day (3.00 cfs/msf). Depth to groundwater level in the vicinity of the pond was much greater i.e. 3.048 m (over 10ft) as compared to other channels where it ranged only from 0.6m to 1.52m (2 ft to 5 ft). In overall, seepage loss results from the pre-lining ponding tests in the FESS project area indicated average distributary seepage rates 57 mm/day (2.15 cfs/msf) for the test in production part of project.

On the other hand, the seepage rate on the experimental channels in different sections under different lining techniques ranges from 25 mm/day (0.96 cfs/msf) to 68 mm/day (2.6 cfs/msf) that are discussed in the coming section.

6.3 Post-Lining Seepage Measurements

The seepage measurements on the channels that have been lined under this project, post-lining seepage measurements are planned. Overall twenty-five ponding tests will be conducted. The post-lining seepage investigations in the project area are aimed at establishing relative performance assessment of various lining types implemented in the project. The programme of post-lining seepage investigations has been started on some canals in January 1999 and these tests were completed over the canal closure period of 2000-04. The post lining seepage evaluations presented here are based on seepage loss measurements obtained through twenty five ponding tests covering diverse lining types on the newly lined channels 1R/3R Qaziwala (17 tests), 3R-Hakra (3 tests), 1R/ Bahadarwah (1 test), Najibwah (1test), Shadab (1test) and 2L/3R (2 tests). (Table A.6) and (Figures 6.1 and 6.2)

Although the comparisons between the prelining and post lining seepage investigation conditions use the same kind of test (ponding), the loss rates are very small, sometimes of the same order as the evaporation adjustments. Some of the lining types examined involve geomembrane underlying a non-water proof layer of precast concrete elements with significant gaps between them, and in such cases, it is

very difficult to seal the ends of the test ponds. In some of the later tests, accuracy was improved by constructing counter ponds to balance the hydrostatic head across the bunds. In post lining ponding test either pumped ground water or canal water was used for filling or refilling. The result indicated quite low seepage rate ranging from 30 mm/day (1.13 cfs/msf) to 0.53 mm/day (02 cfs/msf). Expressed in the more generalized quantitative loss terms, bulk channel seepage losses based on the discharges at distributary heads of test channels lie in the range of about 3 to 5 percent and the post lining is .01 to .5% of the available inflows and are given in Table A.6.

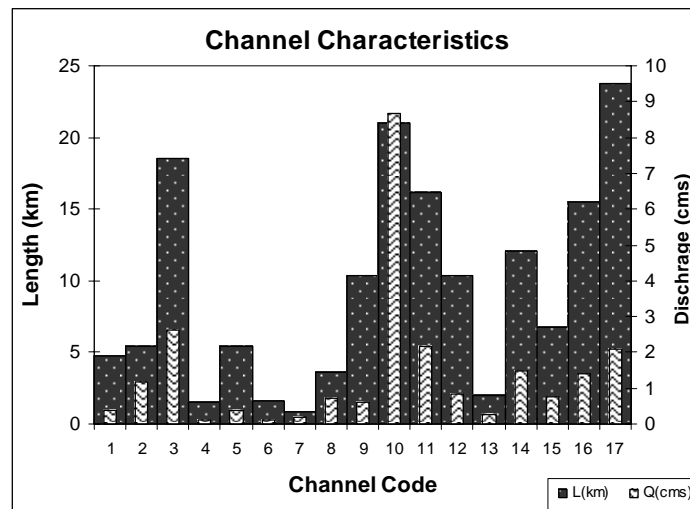

Figure 6.1 characteristics of the channels under production component

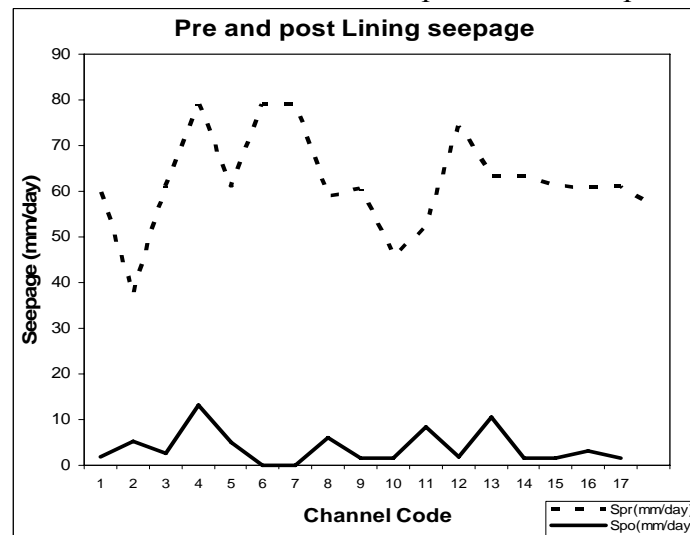

Figure 6.2 Pre and post-lining seepage from production component of the canals.

6.4 Premise for Estimation of Post Lining Seepage Losses

Ponding tests on geomembrane lined sections with precast or insitu concrete, brick or soil protective covers are observed to be confronted with the problem of encountering the false seepage. This may happen as the placements of pond dikes on such back sealed linings is posed with the difficulty in achieving a perfect sealing with the underlying water proofing geomembrane when compared with the front sealed linings where the surface provides the desired water proofing dikes for such ponded reaches rest on external surface, therefore leaving a potential leakage path underneath the linings protective layer. According to Snell (1996), such false seepage, if interpreted as real seepage over the pond's wetted area, could amount to anything from 1.22 to 80 mm/day (05 to 3 cfs/msf). Since FESS linings are aimed at drastic seepage reductions (possibly total elimination) of prelining seepage rates, the ponding tests on back-sealed linings may remain inconclusive. Tests on front-sealed linings, especially the trapezoidal in-situ lining without geomembrane Type-5b (See Figure 5.6 in chapter 5) and the parabolic channels Type-4 (See Figure 5.10 in chapter 5) rank high in more accurate estimation of seepage losses since they are not prone to such problems.

A successful remedy to the problem of encountering false seepage in back sealed linings was found by Snell (1999). He proposed the erection of counter ponds adjoining to both sides of test pond. Filling of these ponds up to the water level in the test pond adequately provided for elimination of false seepage occurrence through pond dikes. The resulting seepage estimations therefore, can be reliable assumed as the actual seepage losses.

6.5 Comparison of Seepage For different Types of Lining under Experimental Component.

Seepage loss estimation from pre and post-lining ponding tests on the diverse test lining types over hard and soil covers in channels 1R/3R Qaziwala, 3R/ Hakra, 1R/Bahadarwala, Najibwah, Shadab and 2L/3R along with pertinent seepage reduction levels are presented. It can be seen from Table 6.1 that the experimental lining types succeeded in reducing the loss rate to as near zero as could be measured. The significance of these results is discussed in the coming section under

experimental lining types. With considerable variation in condition from one place to another, and with only one reach tested for each lining type, the values are only indications of the success of the various types in achieving the water tightness. Different graphs have been made to correlate the channels characteristics with the seepage, see Figures 6.3 and 6.4. Under experimental lining, there are two main category of lining. Each one is discussed here separately as follows.

6.5.1 Lining with Hard Cover

The following are the brief summary

- a) Types 1b and 1c of precast interlocking slabs over geomembrane with and without geotextile, showed considerable residual seepage. The sharp precast slab edges had punctured the underlying geomembrane in these types as reported by the team who had installed these tests by lifting a few protective slabs for secure placement of pond dikes,

Table 6.1 Pre and post-lining seepage rate of geomembrane with hard and soil cover under experiment component

Test No	Channel	Lining Type	Canal geometry			Seepage rate (mm/day)		Reduction %
			Q(cms)	BW(m)	D(m)	Pre	Post	
1	1R/3R	2a	2.6	4.5	1.2	39.62	29.57	25.38
2	1R/3R	2c	2.6	4.5	1.2	39.62	13.11	66.92
3	1R/3R	2b	2.6	4.6	1.2	39.62	12.50	68.46
4	1R/3R	9	2.6	3.3	1.3	39.62	3.05	92.31
5	1R/3R	5n	2.6	2.9	1.3	39.62	0.30	99.23
6	1R/3R	5cd	2.6	2.4	1.2	67.06	0.61	99.09
7	1R/3R	1b	2.6	2.8	1.2	67.06	26.82	60.00
8	1R/3R	5b	1.7	2.4	1.1	67.06	18.29	72.73
9	1R/3R	5c	1.7	2.4	1.1	54.86	1.37	97.50
10	1R/3R	6	1.1	2.1	0.8	60.05	1.62	97.31
11	1R/3R	2b	0.9	2.5	0.8	36.58	25.30	30.83
12	1R/3R	2c	0.9	2.5	0.8	36.58	3.35	90.83
13	1R/3R	2a	0.9	2.5	0.8	41.45	36.58	88.24
14	1R/3R	1c	0.9	1.8	0.8	35.97	18.59	48.31
15	1R/3R	3b	0.3	0.9	0.6	39.62	5.79	85.38
16	1R/3R	3a	0.3	0.9	0.6	39.62	7.62	80.77
17	1R/3R	7	0.3	0.9	0.6	39.62	8.84	77.69
18	1R/(Bah)	4	0.1	0.9	0.3	69.19	10.97	84.14
19	3R/Hakra	Op1	8.7	11.9	1.3	30.48	15.54	49.00
20	-	Op3	8.7	11.9	1.3	24.38	2.44	90.00
21	-	Op2	7.8	10.7	1.3	36.58	7.92	78.33

Continued Table 6.1 Pre and post-lining seepage rate of geomembrane with hard and soil cover under experiment component

22	Najibwah	5a	1.2	4.3	0.8	36.58	1.22	96.67
23	Shadab	8	0.1	0.9	0.3	60.96	0.91	98.50
24	2L/3R)	4lg	0.3	1.5	0.4	60.96	16.46	73.00
25	2L/3R	4l	0.3	1.5	0.4	60.96	17.37	71.50

- b) A high degree of seepage reduction (91%) was observed for type 2c (T shaped precast slabs with joint sealants and without geomembrane and geotextile). Type 2b (T shape precast slabs with geomembrane and geotextile without joint sealant) exhibited a poor seepage control efficiency. Test on another variant 2a (T-shape precast sides with joint sealant on wall and geomembrane on bed) remained inconclusive as the Post lining seepage losses on this section showed a rise in water loss quantities compared to the prelining seepage. Probing the cause for the discrepancy through digging out soil under the canal berm on external sides revealed the poor lining installation with the joint sealant missing between a numbers of lining profiles. Seepage tests were repeated at higher discharge of above types during the canal closure 2003. The reduction in seepage of type 2a (25%), 2b (68%) and 2c (67%) were observed,
- c) Tests on Types 3a and 3b i.e. geomembrane with precast 50 mm (2 inch) plain slab concrete covers with and without the intermediate geotextile protection showed fairly high seepage control as 81% and 86%, respectively,
- d) Type 4lg the parabolic geomembrane partially geotextile without joint sealant showed fair success of seepage reduction of 74%,
- e) A moderate degree of seepage reduction 72% was observed in type 4l that represents parabolic sealed joints without geomembrane and geotextile,
- f) Type 4 , the parabolic precast channel with sealed joints but no geomembrane showed fair success with a residual seepage of the order of 5.2 mm/day (0.2 cfs/msf) in place of prelining seepage rate of 68.48 mm/day (2.6 cfs/msf) . This seepage control was achieved after the removal of mortar from the wet surface of the joint and place joint sealant in contact with both precast units at each joint,
- g) Type 5a i.e. geomembrane with geotextile underlying 76 mm (3 inch) in-situ concrete with joint sealant showed a higher degree seepage control of 97%,

- h) A moderate degree of seepage reduction, 73% was observed in the Type 5b that represents the conventional insitu concrete linings without geomembrane,
- i) The geomembrane under in-situ concrete, Type 5c showed as near to zero seepage as can be measured. As this type replicates the production lining with a thinner geomembrane, it is the most probable that the production lining would generally provide a high degree of seepage control,
- j) A higher degree of seepage reduction 99% is observed in the Type 5cd that represents the textured geomembrane without geotextile overlain by 76 mm (3 inch) insitu concrete without joint sealant
- k) A higher degree of seepage reduction 99% is also observed in the Type 5n that represents the geomembrane overlain by 50 mm (2 inch) in-situ concrete with geomembrane and geotextile without joint sealant,
- l) This Type-6 has 97% reduction in seepage losses. The post lining seepage is negligible.
- m) A moderate degree of seepage reduction 76% observed in Type 7 that represents tongued and grooved precast slab, 76mm (3 inch) bed in one piece, over geomembrane protected with geotextile layer,
- n) A higher degree of seepage reduction 98% was observed in the Type 8 which is 50 mm (2 in) precast small channels without geomembrane, geotextile and joint sealant,
- o) Test on Type 9: Geomembrane overlain by 50 mm (2 in) precast slabs edge beam, mortar joined with and without geotextile showed high seepage control of the order of 3.16 mm/day (0.12 cfs/msf) in a place that showed 39.5 mm/day (1.5 cfs/msf) before lining. This represents a fair degree of success of 50 mm (2 in) precast slabs with loss reduction up to 92%, and
- p) Option 3 on 3R-Hakra i.e. geomembrane under concrete filled mattress showed high degree 90% of seepage control.

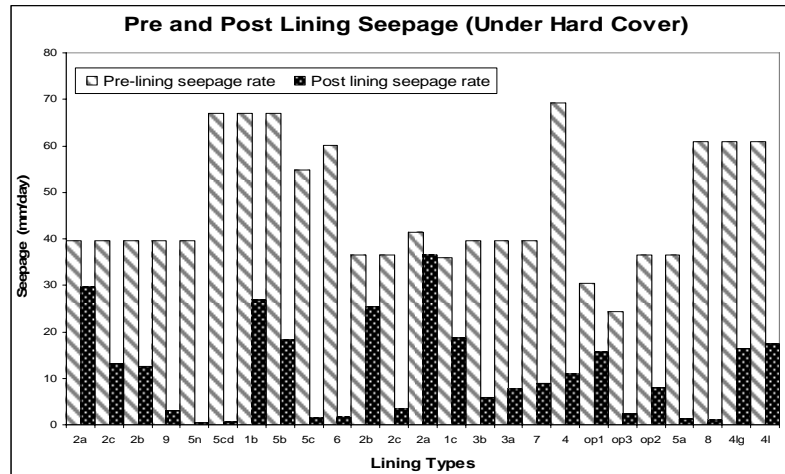

Figure 6.3 Seepage from canals using geomembrane under hard covers

6.5.2 Lining with Soil Cover

Seepage loss estimates from post lining ponding test on the lining types with soil cover experimental in the channel 3R distributary. The seepage reduction levels are given in Table 6.1, Figure 6.4.

- a) Option-1 on 3R-Hakra, only bed lined with geomembrane with 450 mm (1.5 ft) nominal soil cover showed an approximately seepage rate of 15.5 mm/day (0.051 ft/day). This represents a fair degree (49%) of success for lining of bed only, and
- b) Option-2 on 3R-Hakra i.e. geomembrane lining on both bed and sides with 450 mm (1.5 ft) of soil cover showed a moderate seepage control exceeding 78%.

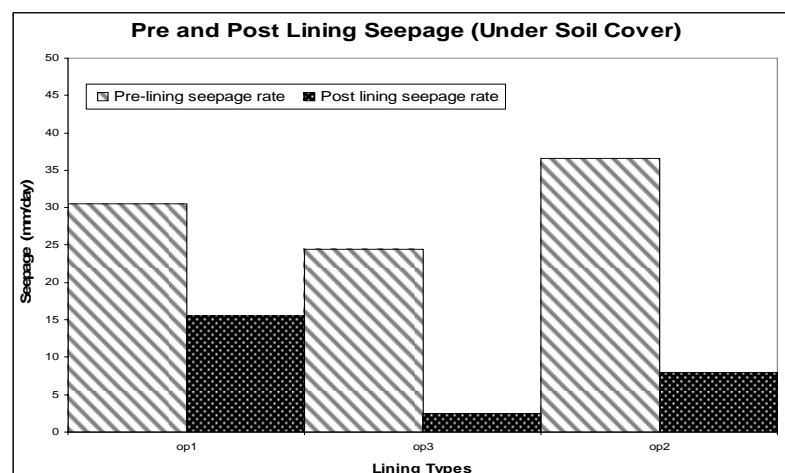

Figure 6.4 Seepage from canals using geomembrane under soil cover

6.6 Comparison of Seepage using different Measurement Techniques

6.6.1 Pre-Lining Seepage Estimates from the Ponding Tests

The initial seepage investigation in the FESS area comprised of five ponding tests on four selected channels i.e. Najibwah, 1-R/3R Qaziwala, 1L/3R and 4-R distributaries during the canal closure in January, 1998. The five ponding tests on these channels, where either canal water or pumped groundwater was used for filling, indicated quite low seepage rates ranging from 33.5 mm/day (0.11 ft/day) to 48.76 mm/day (0.16 ft/day) except on one channel (1L/3R) where seepage rate of 112.76 mm/day (0.37 ft/day) was observed. Depth to groundwater level in the vicinity of the pond was much greater over 3.05 m (10 ft) as compared to other channels where it ranged only from .61 m to 1.52 m (2 ft to 5 ft). The surprising low seepage results from these tests reported by IWASRI (International water and salinity research institute) in the World Bank seminar. (Bodla, et al., 1998) led to series of discussion that are being discussed in the coming section.

These deliberations pointed out need to extend the ponding tests into the subsequent canal closure periods besides undertaking studies to compare these with inflow-outflow tests to establish the propounded generality of these results. In overall, the seepage loss results from the ponding tests in the FESS project area indicates average distributary seepage rates from 36.5 mm/day (0.12 ft/day) to 67 mm/day (0.22 ft/day) for the test channels Najibwah, 1R/3R Qaziwala, 4R Haroonabad, 3R Khatan and 1R Bahadarwah. An exception to this range of seepage loss rates was found in the slightly higher mean seepage rate of 85 mm/day (0.28 ft/day) for the channel 1L/3R. Ponding tests in the small channel suggest a mean seepage rate of 61 mm/day (0.2 ft/day) of the FESS project area. Expressed in the more generalized quantitative loss terms, bulk channel seepage losses based on the discharge at the distributary heads for the various test channels lie in the range of about 3 to 5 % of the available inflows.

6.6.2 Pre-lining Seepage estimates from inflow –outflow tests

The inflow-outflow seepage tests in the project area comprised fourteen extensive series with seven to eight replications for each test following undertaking of the initial ponding experimentation. The pre-lining inflow-outflow measurements show

average seepage rate ranging from 97 mm/day (0.32 ft/day) to 204 mm/day (0.67ft/day) for the test channels 1R/3R, 1L/3R, Najibwah, 4R Haroonabad and 3R Khatan distributaries. An average seepage rate of 165 mm/day (0.54 ft/day) for the project channels to be lined is estimated through inflow–outflow method. These quantities when accounted in percentage loss estimates, suggest seepage losses varying between 5 to 10% of respective inflow heads for various unlined channels in the project area. A summary of in-outflow and ponding test results is given in the Table A.7 and analysis shown graphically in Figure 6.5

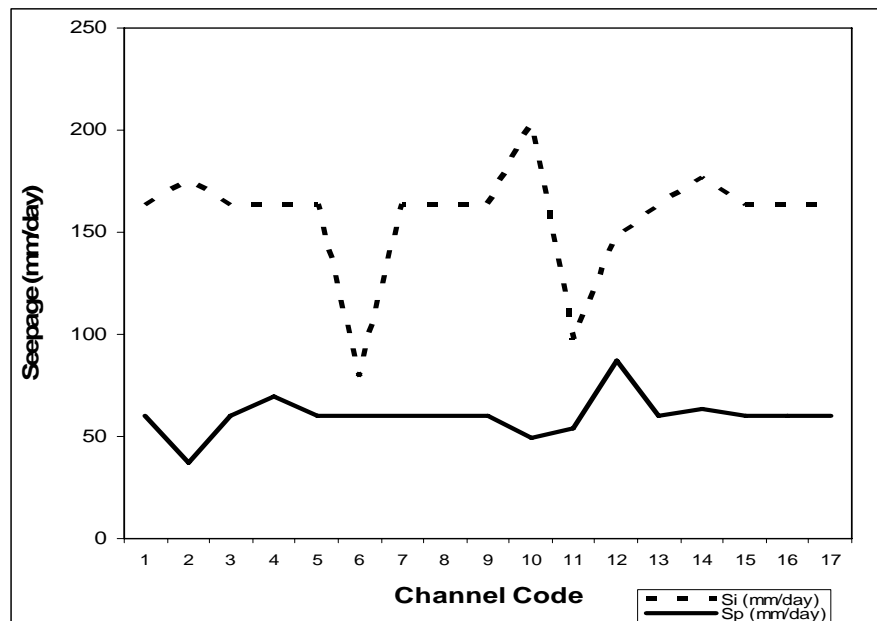

Figure 6.5 Seepage measurement by different techniques

Groundwater table measured in the locality and soil characteristics are also presented in Table 6.2 and Figure 6.6. From this table, it is clear that most of the soil is between silty sand and loam in the project area.

Table 6.2 Ground water level and soil characteristics in the FESS project Area

Channel No.	Channels	Lining Types	Soil type R/B-B- L/B	Av. W/T (m)
1	Girdariwala Minor	PL	SL - S	0.914
2	Najibwah Minor	PL	SiL - SL	1.524
3	Bahadarwah Minor	PL	SiL	1.524
4	1R/Bahadarwah Minor	EL (1c)	SiL	1.829

Continued Table 6.2 Ground water level and soil characteristics in the FESS project Area				
5	Bhukan Disty	PL	SL - S	1.219
6	Shadab Minor	EL (1c)	SL	2.134
7	Bhaku Shah disty	EL	SL	1.524
8	1R Hakra disty	PL	SiL - SL	1.829
9	2R Hakra disty	PL	SiL - SL	1.524
10	3R Khattan disty	EL (op-2a, op-1a,op-2b,op-1b)	SiL - SL	1.372
11	1R/3R Hakra disty	EL (2,1,5c,6,1b,5c,1c)	SiL - SL	1.372
12	1L/3R Hakra disty	PL	SL	1.372
13	2L/3R Hakra disty	PL	SL	1.981
14	4R Hakra Disty	PL	SiS	0.914
15	1RA/ 4R Hakra Disty	PL	SiS	0.762
16	1R/4R Hakra Disty	Pl	SiS	1.067
17	1L Hakra	PL	SiL - SL	1.372
R/B = Right Bank				
B = Bank				
L/B = Left Bank				

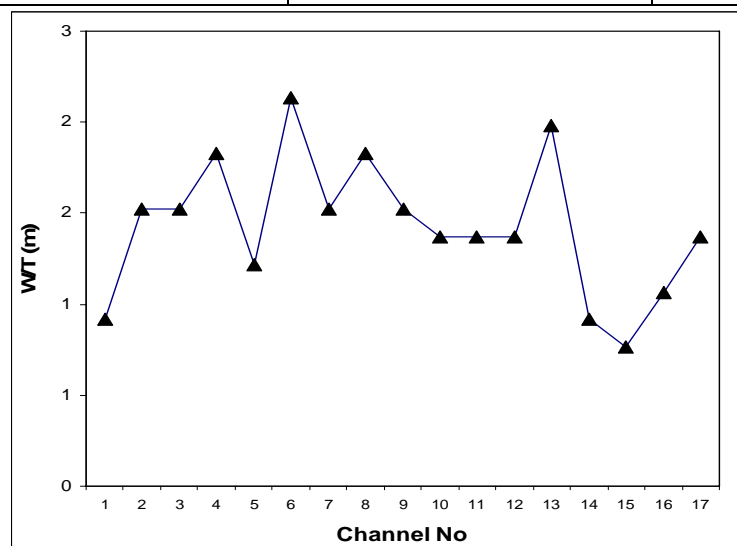

Figure 6.6 Water table level in FESS project Area.

6.6.3 Statistical Analysis of Seepage Determinations

Seepage loss rates derived from the ponding and inflow-outflow tests for the project area are shown in the graphical comparison form for the two techniques presented in the Table A.7. The observed variation in estimation of seepage rates in FESS area by the two methods is consistent with a number of other reported seepage investigations

carried out in the region. (Christopher, 1981; Smith and Turner, 1982; Weller, 1981; Deacon, 1983 and 1984, and Weller and McAter, 1993).

Statistical evaluation of the two types of tests carried out in the unlined FESS canals is attempted here to support logical interpretation for the observed discrepancies between the results obtained from the seepage measurements. These tests were conducted under strict control under several replications under each test method, therefore reducing the random independent errors in proportion to the square root of number of replications. Evaluation of statistical indices e.g. mean values, standard deviations, co-efficient of variation, mean standard errors and 95% confidence intervals was considered necessary to assess reliability of the results and the accuracy of one technique over the other for conclusive estimation of realistic seepage loss rates for the project area.

Derivations of these statistical parameters for the ponding and inflow-outflow seepage tests in the FESS project area are summarized in Table A.8 and shown in Figures 6.7 and 6.8.

Mean standard deviation for the ponding test replications conducted to arrive at an average seepage rate for the test sites on the unlined channels varies from 1.84 to 5.79 mm/day (0.07 to 0.22 cfs/msf) with co-efficient of variation ranging from about 3 to 8 % and absolute mean standard error varying as 0.26 to 1.32 mm/day (0.01 to 0.05 cfs/msf) for the ponding tests. Analysis for the inflow-outflow test replications on these channels reveals exceedingly higher magnitudes for the observed standard deviations 15 to 31 mm/day (0.57 to 1.18 cfs/msf) with resulting coefficients of variations ranging between 9 to 21.5 % and mean standard error values varying between 5 to 17 mm/day (0.20 to 0.65 cfs/msf.). In otherworlds coefficient of variation in inflow outflow is more than ponding test method.

6.6.4 Interpretive Evaluation of Seepage Investigation

Although the ponding test section covered only a fraction of the much longer inflow-outflow reaches, the comparison of the seepage rates between the two methods is of interest to make concluding statement on true seepage losses in FESS area. With the sole exception of the lower reach on canal 1R/3R, where the rates were almost equal, the inflow-outflow method gave significantly higher rates, by ratios from a modest 1.5 to a dramatic 5. The absolute difference between the seepage rates given by the

two methods varied from 39.5 to 132 mm/day (1.5 to about 5 cfs/msf), those differences being many times the sum of standard errors. This shows that, in all but

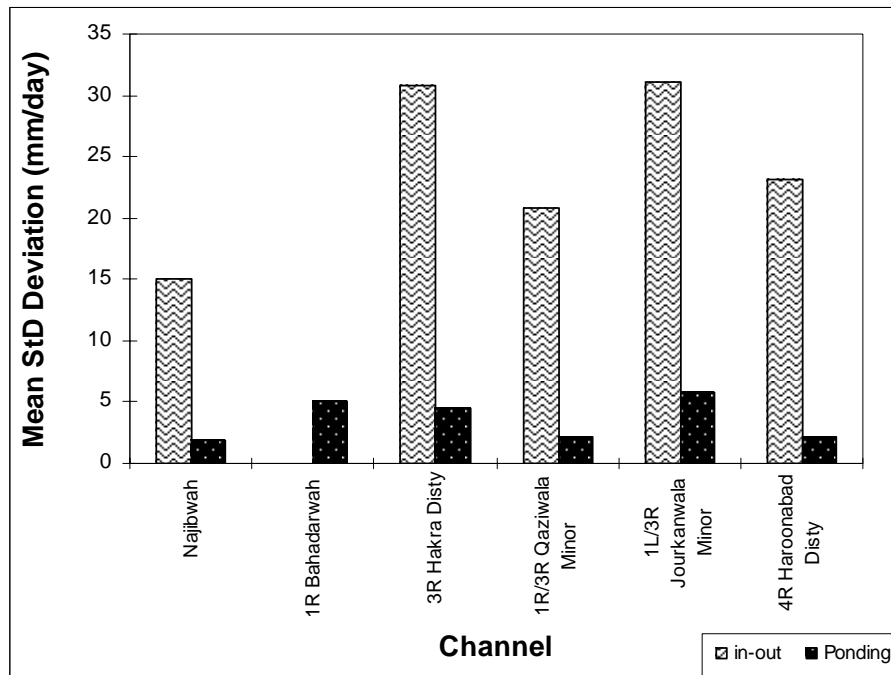

Figure 6.7 Graphical representation of Standard Deviation (mm/day)

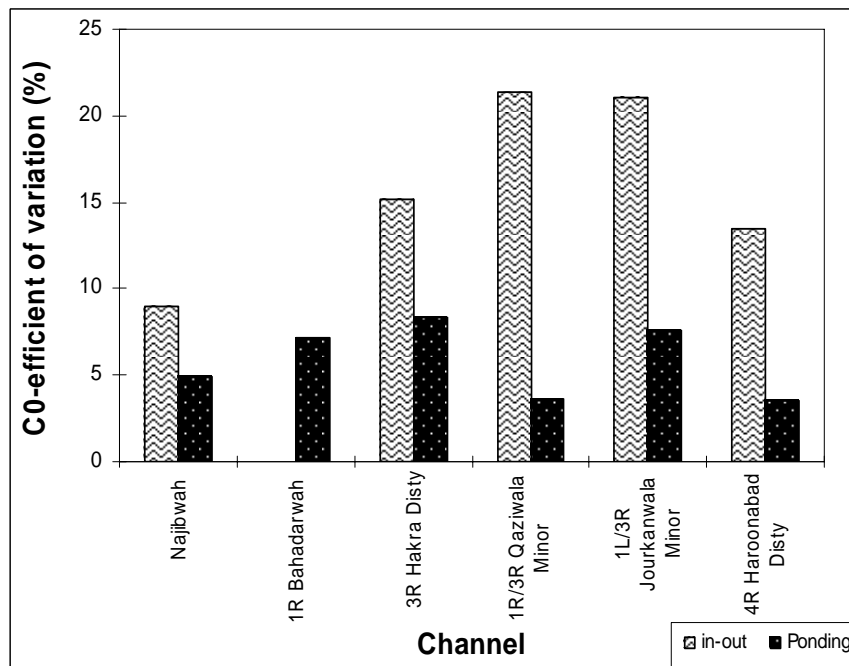

Figure 6.8 Graphical representation of Co-efficient of Variation (%)

that one reach on 1R/3R, the difference between the inflow-outflow result and the lower ponding result was far larger than could be explained by random independent

errors. The existing tendency of inflow-outflow tests to always produce higher seepage rates than the ponding method can at best be attributed to unknown systematic errors with one sided bias.

The observed variation in estimation of seepage rates by the ponding method and inflow-outflow methods is evidenced through a number of other investigations in the region and the other parts of the world. Ponding method is considered to be the most accurate method of seepage measurement and is frequently used as a standard with which to compare other methods. Deacon (1984), Siddiqui, et al. (1993) and Snell (1996, 1999) considered the inflow-outflow method as inherently imprecise since it measures the loss rate as difference between two large quantities i.e. inflow to the channel and the outflow, the seepage loss must therefore be larger or the inherent errors in the measuring technique makes the results meaningless

This uncertainty of estimation is attributed to unidentifiable systematic or random errors in individual discharge measurements, and in case of current metering it can be sufficiently large to mask the actual seepage losses. In the ponding method, the water loss is measured directly, rather than a small difference between the large quantities which gives fundamentally a better degree of precision than the inflow-outflow method. Smith (1982) reported the extensive seepage research programme under Victorian Water Commission , Australia concludes that ponding of relatively short sections of channel removes the large items from the water balance equation giving a substantial improvement in the accuracy of seepage estimates. Christopher (1981) reports variation of apparent inflow outflow seepage rates with time, and cites that in his experience continuous inflow outflow reveals this tendency and produce time averaged figures agreeing with ponding tests. However, the method is known to involve considerable costs and disruption to the operation of the channel, unless used during annual canal closure periods.

6.6.5 Hypothetical Explanation of Observed Differences

A through analysis of various hypothetical explanations to the observed variations in ponding and inflow-outflow seepage results in FESS project area suggests that the difference are due to some systematic accumulating errors of measurement rather than to occurrence of random independent errors. Major types of systematic errors

conceived to explain the observed discrepancies between ponding and inflow-outflow results were,

- a) Sediment sealing effect in ponding,
- b) Filling pond with source different from canal water,
- c) Dynamic velocity effect of flowing versus ponded water,
- d) Use of different measurement instrument (e.g. smaller current meter or flumes) for test channel and offtaking discharge,
- e) Any leakage around offtaking structure, and
- f) Occurrence of unrecorded/undetected orifices in longer reaches of inflow-outflow tests.

Thorough analytical evaluation of each of these speculations showed that the errors a, b, and c above are negligible in the condition of well aged unlined channel in the country. Error (a) seems unlikely, the canal being in regime for years with the same sediments. Error (b) might occur if the filling water had high sodium absorption ratio and the permeability of the canal sub-grade were mainly due to the clay particle, but these do not apply in canals under consideration. Further, the observed hour to hour and day to day consistency of apparent ponding rates does not support occurrence of both errors (a) and (b). The hypothetical dynamic effect error (c) would only exist if the flow velocity is very high and this is not plausible here. Error types (d) and (e) are inherently plausible but hydraulic reason is found to suspect a significant systematic bias between the methods. If these were the main reason for the observed tendency, the seepage rate ratio between methods would tend to be greater when there are more offtakes, but the results show no much correlation. Error f could explain the observed tendency but with careful control of the inflow-outflow test reaches possibility for these undetected losses virtually non-existent.

6.6.6 Conclusive Statement on Seepage Losses the Project Area

The above diagnosis of possible errors of seepage rate measurement in FESS area and elsewhere in similar conditions along with associated statistical analysis lead to conclude that the ponding test results give more reliable estimates compared to the inflow-outflow measurement. The average ponding seepage rates given in Table A.7 therefore, are adopted to qualify the seepage from the channels to be lined in the FESS project area.

6.7 Impact of Seepage Investigation on Future Phase II Project

Planning of the proposed future surface and subsurface phase II project would need to follow impact evaluation of the various conservation measures adopted under FESS project. The World Bank Appraisal Report SAR (1992) anticipates that on average the proposed project would cause watertable in the project area to fall by 0.3 to 0.46 m (1 to 1.5 ft). Estimated incremental surface water availability at root zone (with project) is shown in World Bank (1992) as 69,360 hectare-m (91,000 acre-ft). These estimates mean significant reduction of subsurface drainage requirements during phase II. Phase II includes lining of small channels in the project area as one of the major recharge reducing measures along with the proposed surface and interceptor drainage, the measured seepage values however do not confirm the expected benefits. Prediction for additional water availability through the proposed lining works in the project area is worked out here on the basis of estimation of overall ponding and inflow outflow seepage quantities presented in Table A.9.

Seepage estimates given in Table A.7 results from extrapolation of the measured ponding and inflow outflow seepage rates to all the channels which would be lined under the ongoing projects programme. Based on 295 average yearly canal operational days, the ponding and inflow outflow tests suggest a total saving of about 1,855 hectare-m (15,215 acre-ft) and 5,876 hectare-m (48,182 acre-ft) respectively. The corresponding estimates of water availability at the root zone calculated by assuming 25% operation and field losses, predict for a more realistic ponding based estimates of water availability of 1,390 hectare-m (11,400 acre-ft) annually verses an optimistic or highest estimate of water saving of 4,406 hectare-m (36,137 acre-ft) annually. The estimated lowering of watertable in the area, calculated for the total project canal command area of 104,000 hectares (260,000 acres), vary from the ponding test based estimates of 6 cm per year (0.20 feet per year) to inflow outflow tests based exaggerated anticipated annual lowering of 21 cm (0.70 ft), assuming soil porosity as 20% for the soil in the project area.

The observed seepage rates while compared with the project appraisal stage predictions of anticipated lowering of watertable and predicted additional water availability through all water conservation measures (World Bank, 1992) do not seem to promise significant reduction of the requiring implementation of more expensive future surface and subsurface phase II project.

6.8 Seepage Data Analysis

6.8.1 Classical Regression Technique

Different statistical parameters such as mean, mode, coefficient of correlation, and standard deviation are computed in to check the true picture of data (see Table A.8). Series histograms are also drawn for each variable that helped in determining the range of data and also whether the data is uniformly distributed (see Figure 6.9).

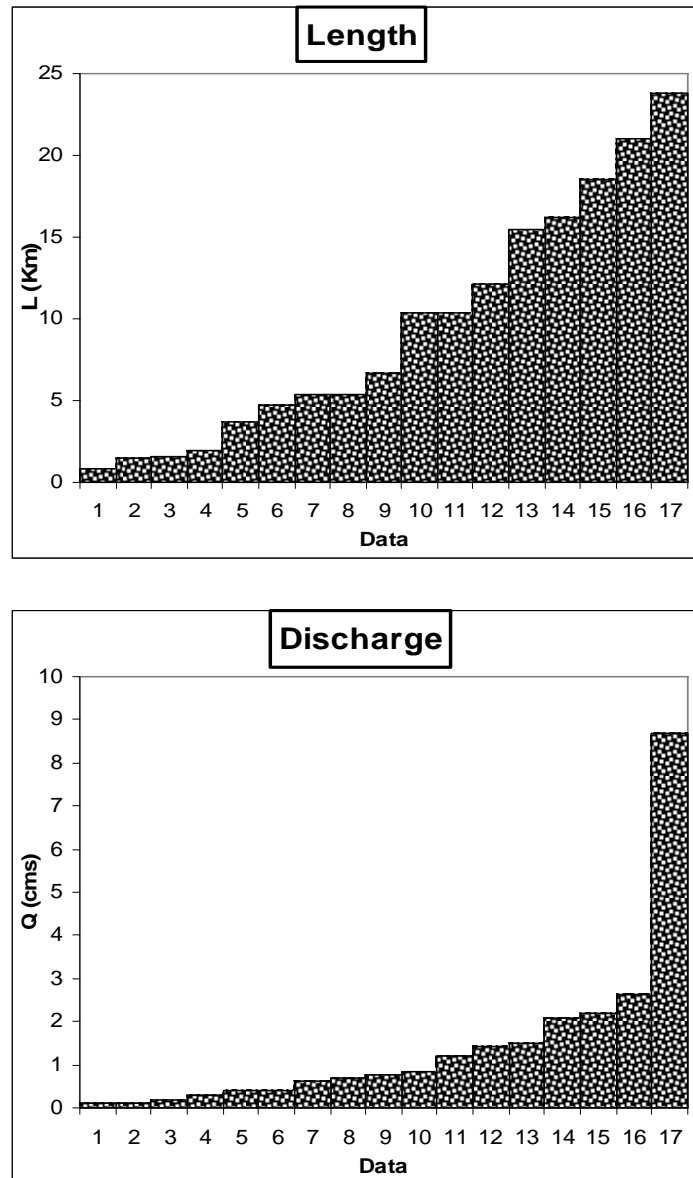
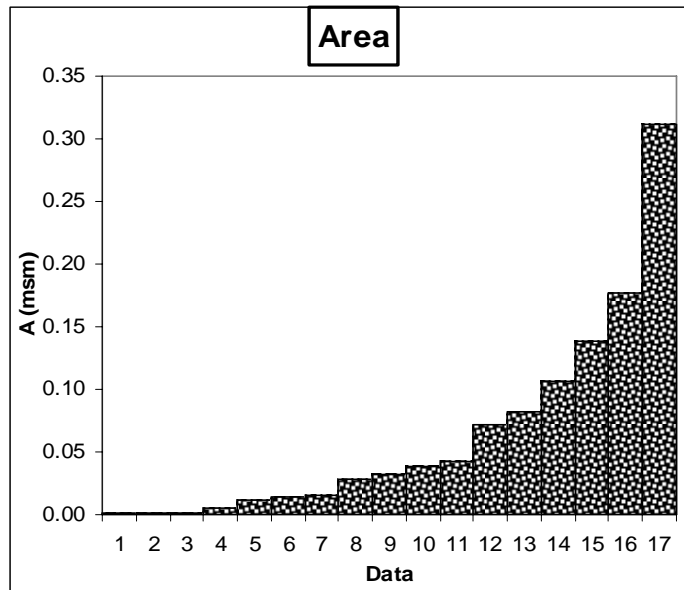

Figure 6.9 Series histograms of seepage variables



Continued Figure 6.9 Series histograms of seepage variables

6.8.1.1 Regression Straight Line Parameter Estimation

Scatter diagrams between different variables are drawn in order to check the correlation between the seepage variables. In this procedure, one variable is selected as independent and all others are as dependent. The scatter plots behaviour is checked to view some definite relation. The one that gives the straight line is selected as model otherwise some fitting techniques are adopted to get the correlation between the variables, (see Figure 6.10).

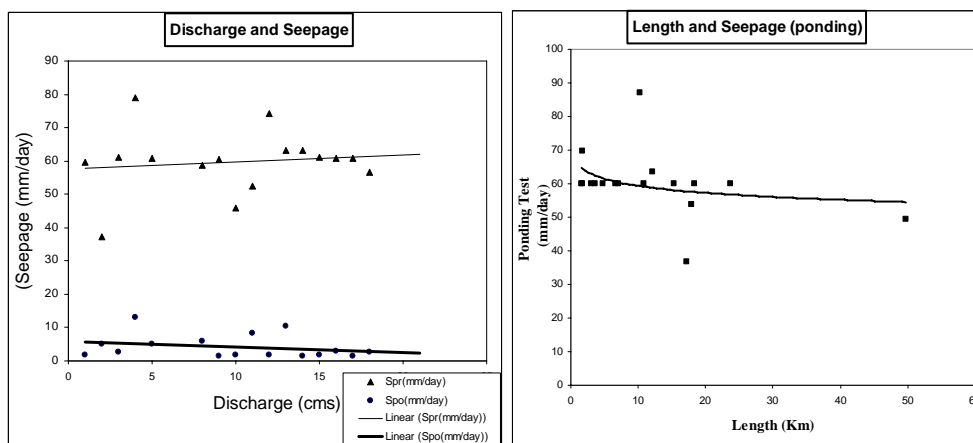
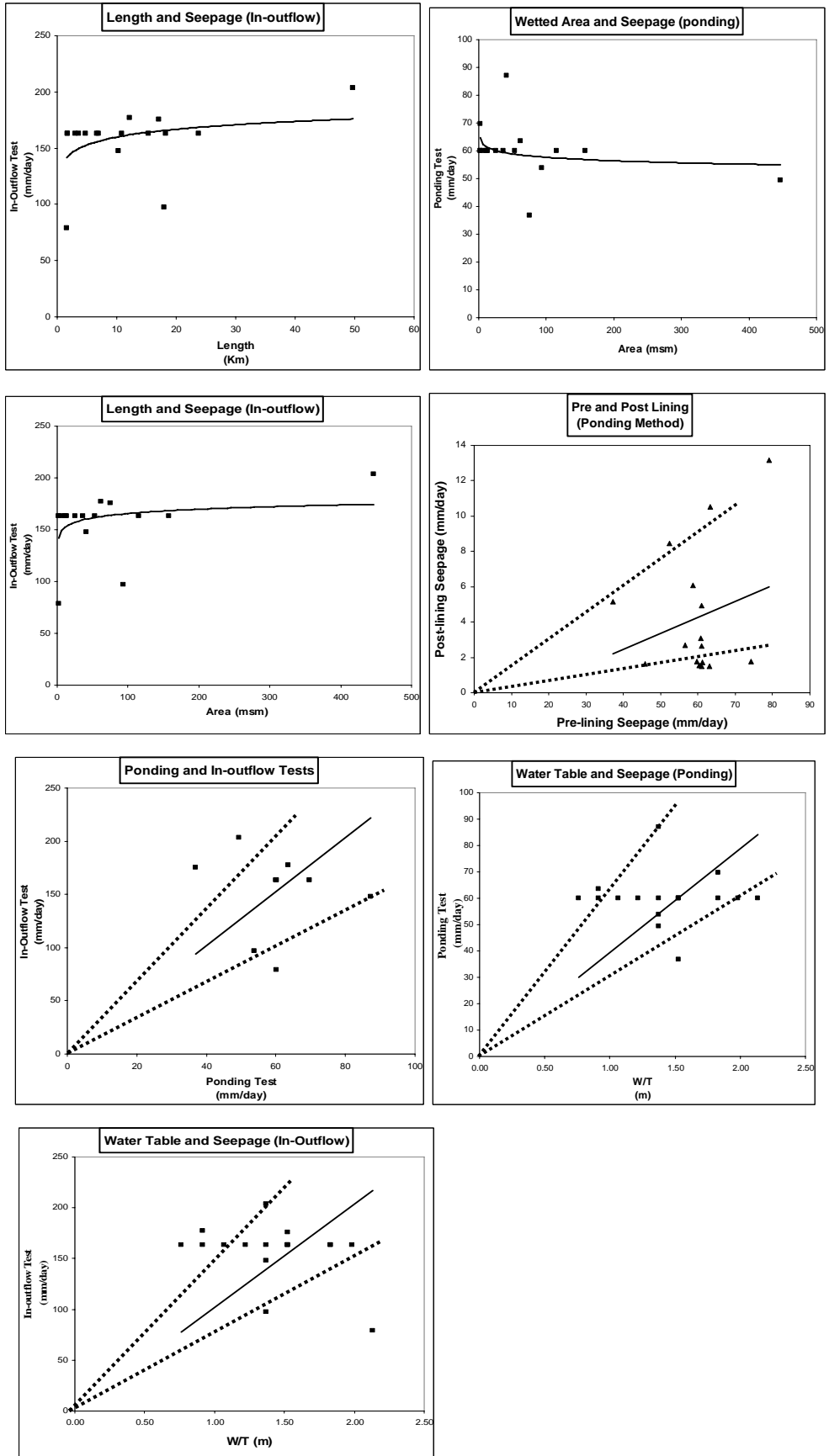

Figure 6.10 Scatter diagrams between different variables



Continued Figure 6.10 Scatter diagrams between different variables

In above scatter diagrams, the solid lines are the trend line and dotted line is the possible regression line passing through the group of scatter points. There are more than one group in each diagram. However none of graph gave the definite relationship. This may be due to the non-uniformity and heterogeneity of the data. Let us first discuss the assumptions for using the classical regression method.

6.8.2 Regression Assumptions

In order to check the reability of model, first following assumptions are checked. If anyone of these assumptions is not satisfied, it is necessary to transform the data in such a format that after the transformation the assumptions are satisfied otherwise, the regression model is not reliable. These assumptions are;

- 1 Linearity assumption,
- 2 Normality Assumption,
- 3 Average of the conditional distribution is equal to zero,
- 4 Constant variance (homoscedascity),
- 5 Serial dependence (Autocorrelation), and
- 6 Measurements are error free.

Looking on the scatter diagrams in Figure 6.10 between different seepage variables, series histograms in Figure 6.9 and also statistical parameters in Table A.8, it is concluded that none of the variables follow the above assumptions so no reliable relation/model can be deviced from the above technique. Hence there is a need for a model that is not only assumption free but also yields reliable results. In this situation, a Fuzzy modelling is suggested that will be discussed in the next section.

6.8 3 Fuzzy Logic Technique applied for seepage analysis

6.8.3.1 Brief Review of General Fuzzy System

In order to clarify the distinction between the formal classical logic and the fuzzy logic it should remember that according to Aristotelian logic if something is true or thought to be true, it is given the number of 1 and its alternative as zero implying impossibility of the phenomenon concerned. Likewise, simply true statements are attached degree of belief as 1 and false ones as 0. As if there is no mixture of these

two states, in other words, partially true or partially wrong in the nature and in the very basis of human thinking and especially philosophical consequents.

The fuzzy logic will attribute degrees to even a scientific belief (degree of verification or falsification) that assume values between 0 and 1 exclusive. Verifiability of scientific knowledge or theories by logical positivists means on the classical grounds that the demarcation of science concerning a phenomenon is equal to 1 without giving room for falsification. The conflict between verifiability and falsifiability of scientific theories includes philosophical grounds that are fuzzy but many scientific philosophers concluded the case with Aristotelian logic of crispness, which is against the nature of further scientific development. Although many science philosophers tried to resolve this problem by bringing into the argument the probability and at times the possibility of the scientific knowledge demarcation and scientific development, unfortunately so far the "fuzzy philosophy of science" has not been introduced into the literature. The scientists cannot be completely objective in their justification for scientific demarcation or progress but ingredients of fuzziness are driving engine for the generation of new theories. All scientific rule bases must be justified, i.e. tested by fuzzy inference engine, which leads to fuzzy scientific domain but for classical understanding and dissemination of the knowledge, the people render them into a defuzzified manner. In fact, the scientific phenomena are all fuzzy in nature and especially the foundations of scientific philosophy include embedded fuzzy components. Dogmatic nature of scientific knowledge or belief, in the science as if it is not doubtful, is the fruit of formal classical Aristotelian logic, whereas fuzzy logic holds the scientific arena vivid and fruitful for future scientific plantations and knowledge generation, (Şen, 2004)

6.8.3.2 Benefits of Fuzzy systems

“The guiding principle of soft computing is to exploit the tolerance for imprecision, uncertainty, and partial truth to achieve tractability, robustness, and low solution cost. What makes fuzzy logic so important is the fact that most of human reasoning and concept formation is linked to the use of fuzzy rules. By providing a systematic framework for computing with fuzzy rules, fuzzy logic greatly amplifies the power of human reasoning” (Zadeh, 1967).

- 1) Fuzzy logic systems use information efficiently, all available evidence used, propagated until final defuzzification, robust to uncertain, missing or corrupted data,
- 2) Fuzzy logic encodes human expert knowledge/heuristics common sense, easily interpreted, constraints are naturally enforced,
- 3) Fuzzy logic systems are cheap, training data are not required, models or joint/conditional probability distributions are not needed,
- 4) Relatively straightforward to design and implement.
- 5) There is nothing fuzzy about fuzzy logic,
- 6) Fuzzy logic is different from probability concepts,
- 7) Designing the fuzzy sets is comparatively easier than any other sort of modeling,
- 8) Fuzzy systems are stable, easily tuned, and can be conventionally validated,
- 9) Fuzzy logic "does not just process control anymore.", and
- 10) Fuzzy logic is a representation and reasoning process

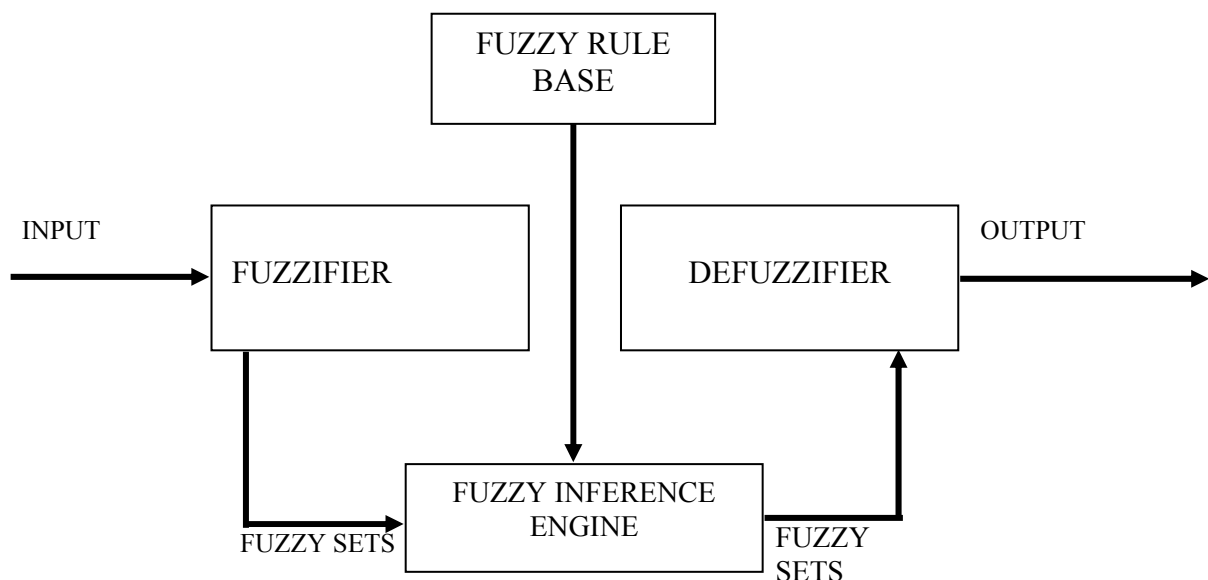

Figure 6.11 Schematic Diagram of Fuzzy Components (Şen, 2004)

6.8.3.3 Individual Fuzzy Set

In order to understand the fuzzy modeling it is necessary to grasp the functioning of each membership function with the data. The membership functions have on the horizontal axis the variability domain of the variable concerned with the membership degree on the vertical axis. In a way, fuzzy functions are transformers of data values to membership degrees or given membership degrees to data value. Such a transformation is referred to as the triggering or firing feature of the fuzzy rules. For instances, in the following figure the fuzzy category of ‘low’ is exemplified through a trapezium close to the origin. There are three data values, which fall within the ‘low’ membership function domain and therefore they trigger (fire) this function with three different membership functions as 0.3, 0.8 and 1, respectively.

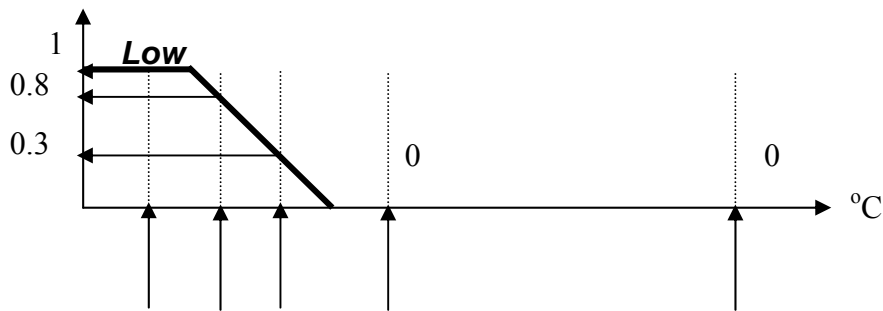

Figure 6.12. ‘Low’ fuzzy member and triggers

This implies that these three data values are all ‘low’ but their low-ness degrees are different. One of them with membership degree of 1 is completely low, however, the one with 0.3 membership degree is the least ‘low’. This implies that there are numerous membership degrees for numerous data values that fall within the range of ‘low’ category. On the other hand, in the same figure the two data values on the right hand side do not fall within the range of this category, which means that they are outside of the range, i.e. they do not trigger or fire the ‘low’ category at all. Hence, for each category the data can be categorized with triggering and non-triggering. The non-triggering has zero membership degree but the triggering has different membership degrees that vary between 0 and 1.

In the following Figure 6.13 similar arguments are valid for the variable of force per unit area but this time with ‘high’ fuzzy function. Herein there are two triggers and two non-triggers.

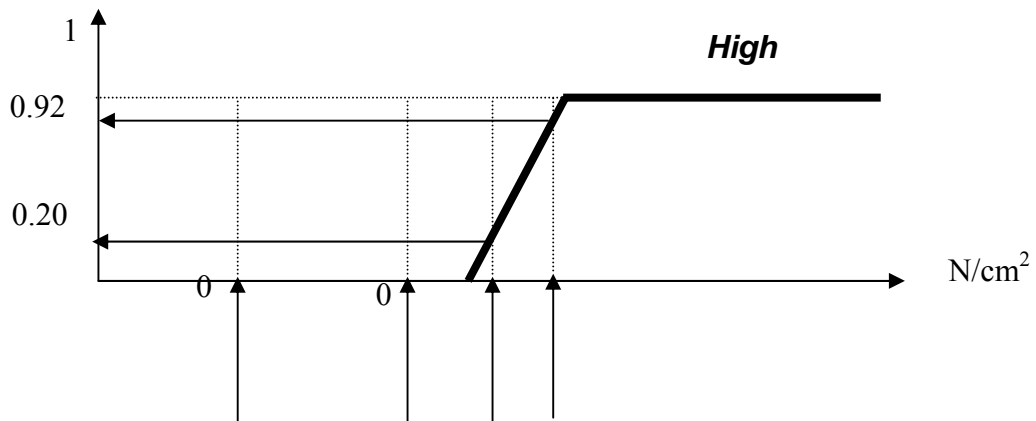

Figure 6.13 The fuzzy 'high' membership function

It is not necessary that the membership functions should be in regular shapes like triangles and trapeziums but they may have any shape provided that they continuously decrease after the maximum degree equal to 1 on both sides or at least on one side. Figure 6.14 shows such a situation with many data entering, which are shown by vertical arrows.

In this case some of them trigger the membership functions and the other do not trigger. It is important to notice that, if the data value falls on the common area of two successive overlapping membership functions, then each data value triggers not only one but two membership functions with two membership degrees for each function. One of these two degrees for the same data will always be greater than the other. It can be thought in such a way that these membership degrees provide a measure of how significantly to each other the data value triggers the two membership functions. Of course, for the same data value the membership function with higher degree of membership is more significant than the other.

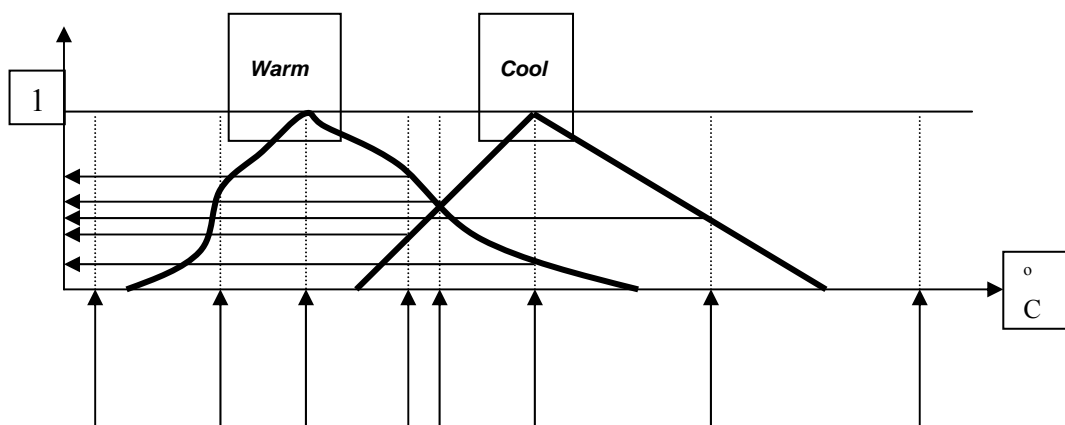

Figure 6.14 Two overlapping fuzzy sets and firing

6.8.3.4 Fuzzy Inputs

The input data is considered as crisp values and accordingly they are shown by vertical arrows. Crispness implies that the data values are certain and intact of any error. However, in practice, this is not the case and most of the data values are either include data or they themselves have fuzzy structure, i.e. they do not represent exact knowledge. For instance, the expressions such as ‘approximately 10 m³/day’, ‘more or less 10 mm’, ‘at least 25 °C’, etc., imply uncertainty, and therefore, they cannot be represented by arrows on the triggering models. Since, they are uncertain and the uncertainty is around (on both, right or left sides) the value with membership value equal to 1, they appear as symmetrical narrow triangles or in the cases of one-sided uncertainty, they are in the forms of right angle triangles. However, in all the cases,

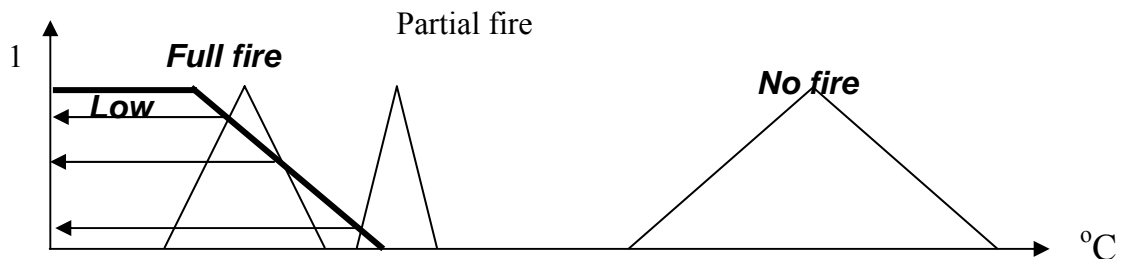

Figure 6.15 Fuzzy input data

the peak of the triangle has membership degree equal to 1. Such a situation is shown in Figure 6.15

6.8.3.5 Fuzzy Inference Engine

In hydrology rather than numbers, qualitative descriptions are dominant at initial information in any reconnaissance study with descriptive linguistic explanations. Ordinary people without proper education thinks in a fuzzy manner because they do not have proper terminology or concrete scientific laws for the descriptions and modeling of the phenomenon concerned. This indicates the effectiveness and naturalist of fuzzy logic, which is linguistic in content, but connective between different categories at the background. In order to distinguish between the classical Aristotelian and fuzzy logics let us consider the statement that ‘force is directly proportional with acceleration’. Such a proposal gives a global logical relationship between two variables, which implies that as the acceleration increases, force also

increases. It is not possible to clearly identify from this statement the following points,

- 1) whether the increase is linear or nonlinear,
- 2) validity domain of both variables, and
- 3) what are the sub-domains of each variable?

In any research, these are significant questions that need proper answers. In the classical scientific educational systems, these points can be objectively identified by measurements and observations. However, herein the very word of observation must be closely examined and its meaning must be explained again linguistically. Measurements need instruments suitable for the study. However, observations may be achieved by human senses and put into words accordingly. Observations are especially significant sources of information in hydrological sciences, medicine, etc. For instance, it is rather impossible for a geologist to set forward logical statements about the geological features in an area prior to making effective field trips. In geological sciences, each area has its special and different features that are not repeated in any area completely. Hence, right at the beginning, it is known that the geological set up of different regions will have common specifications, features, trends, descriptions, etc., but even so, there will be dissimilar features also. It is these dissimilarities that make the comparison or deduction of information on more than two sites to have fuzzy behaviors. This is tantamount to saying that naturally geological patterns at different sites are dissimilar to a certain degree of content. For instance, globally two different sites of soil type might have the same soil types, say, clayey sand, sandy clayey and silty sand, but it is not possible to insist that each soil type has the same degree of membership in these sites. From the classical logic point of view, these two sites are identical to each other without any further detailed specifications. However, the soil investigator is not convinced at all fully that they are identical, because whatever the circumstances, there are uncertainties linguistically which are fuzzy in content. It is possible to ask what is the grain texture of sand in different sites? In general, they will have seepage but not at equal degree, and hence the variation in the seepage can be categorized relatively as 'low', 'medium', or 'high' porosity which allows the entrance of the fuzzy concepts into the assessments. Similar to the word of 'proportionality' in the above proposition, 'porosity' in the description of the same category of soils, cannot be distinctive in sub-categorization. This leads to the general rule that in any logical assessment, sub-

categories are significant, and it is possible to deduce that the more (the finer) the categories, the better is the description.

In fuzzy logic, the fundamental significance is not the sub-categorization, but the relationship between them. So far, one can summarize that for fuzzy investigation of any phenomenon the following steps are a priori necessity.

- 1) Identify the variables for the description of the phenomenon at hand, such as the 'discharge', 'wetted area', and 'seepage'.
- 2) Sub-categorization of the variables which are adjectives such as 'low', 'medium', 'high', 'warm', 'more', etc., and,
- 3) State proposals between the sub-categorization of at least two variables, which must include the logical connections in sentence forms.

Fuzzy logic approach provides a way of identifying vague relationships between different variables that play role in the causal of a certain phenomenon. In fact, the mathematical equations either through analytical or statistical or probabilistic approaches might lead to such relations, but they are attached in more concrete form attached with numbers, where non-numerical effects cannot be taken into consideration. Let us think about the variables effecting the seepage from the surface canal. The following is the list of causatives,

- 1) Type of soil, whether clayey, clayey sand or sandy,
- 2) Water table around the canal, and
- 3) Silt in the flowing water

It is possible to relate each one of these variables to the seepage from the canal and fuzzy pair wise logical statements might appear as follows,

- 1) According to soil type
IF soil type is clayey THEN seepage is low,
IF soil type is clayey sand THEN seepage is moderate, and
IF soil type is sandy THEN seepage is high.
- 2) On the watertable basis
IF W/T is low THEN seepage is high,
IF W/T is medium THEN seepage is moderate, and
IF W/T is high THEN seepage is low.

It is to be noticed, herein, that the soil type and watertable have been divided into three sub-categories each with the specified adjectives.

- 3) Considering the third variable silt in water, how much seepage effected due to this variable, can be stated as,
 IF SW is low THEN seepage is high,
 IF SW is moderate THEN seepage is moderate, and
 IF SW is high THEN seepage is low.

Each fuzzy proposition can be thought of consisting two parts as before and after the word THEN. The part before THEN is the antecedent segment, and after THEN it is the consequent section. These pair-wise fuzzy logical statements can be generalized into triple-wise, quadruple-wise, etc. propositions with care. For instance, for the problem at hand, the antecedent part has three variables, namely, soil type, groundwater table and silt in water. Since each variable has been categorized into three sub-categories, there will be $3 \times 3 \times 3 = 27$ different combinations of these sub-categories and each of these combinations will be attached with a consequent of three sub-categories of the seepage variable. The following is the list of exhaustive logical propositions for seepage from canals (see Table 6.5) Similar tables can be constituted for clayey sand and sandy soil also. Logically filling the consequent part in this table needs careful thought.

Table 6.3 List of logical propositions for predicition of seepage from canal

Soil Type	Watertable	Silt in water	Seepage
Clayey	low	low	high
Clayey	low	moderate	moderate
Clayey	low	high	moderate
Clayey	medium	low	high
Clayey	medium	moderate	moderate
Clayey	medium	high	moderate
Clayey	high	low	moderate
Clayey	high	moderate	low
Clayey	high	high	low

6.8.3.6 Defuzzification

Defuzzification is the reverse process of fuzzification. It converts the confidences in a fuzzy set of word descriptors into a real number. This may be necessary, if it is necessary to output a single number to the user. For example, in an expert system of runoff prediction, it may be necessary to tell the user how many of a certain item is

expected to be in m^3/sec . A representative fuzzy result from two rules is shown in Figure 6.16.

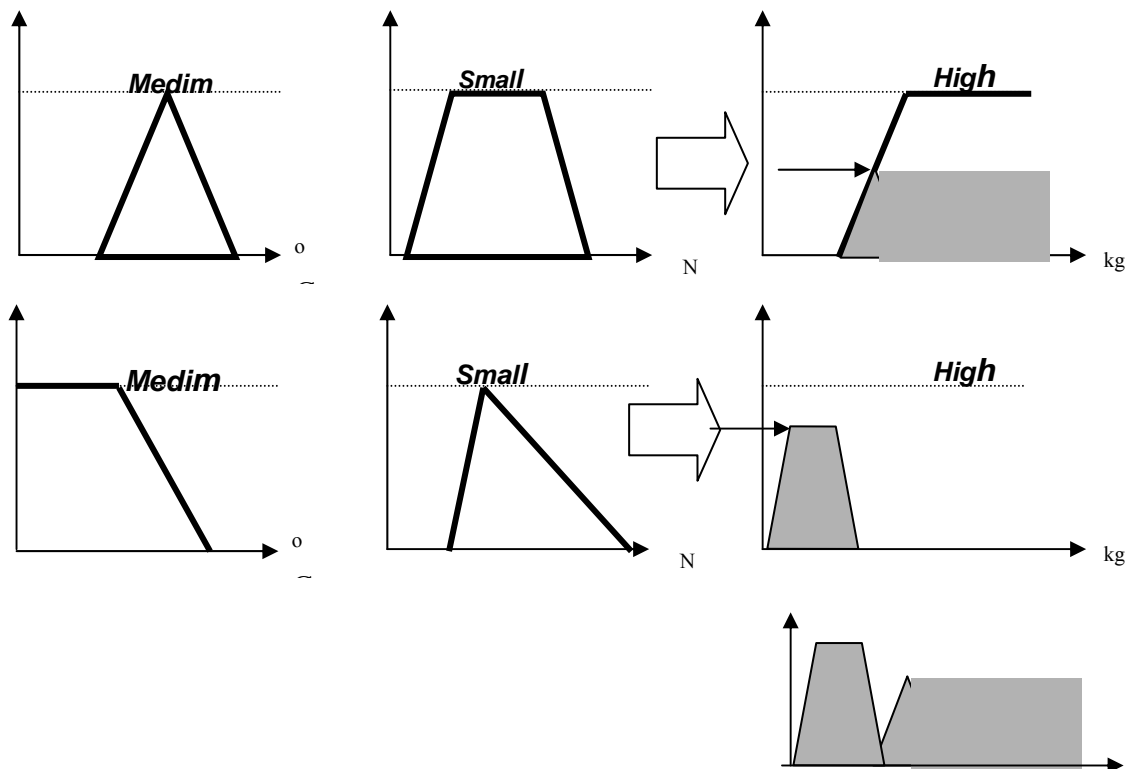

Figure 6.16 Fuzzy result from the two rules

Although there are different ways of defuzzifying: In fuzzy reasoning, quite simple methods are used. It is intuitive that *fuzzification* and *defuzzification* should be reversible. That is, if a number is fuzzified into a fuzzy set, which is immediately defuzzified one should get the same number back again. If defuzzification is to take place, this has implications for the shape of MFs used to fuzzify input variables into fuzzy sets used in the *reasoning process*, which ultimately results in defuzzifying an output fuzzy set. More generally, MFs are defined for output fuzzy set, and use the defuzzify command. There are very many defuzzification procedures available for fuzzy control, but *fuzzy reasoning* applications can usually be satisfied with fewer options. The best shape for a MF depends on its use. If the ultimate output is non-numeric, flat-topped MFs with adjacent functions having maximum overlap are usually best.

On the other hand, if numeric output is desired, peaked functions intersecting at half full confidence are usually the easiest to manage.

The process of defuzzifying a fuzzy set requires knowing representative values that correspond to each fuzzy set member. The representative value for each fuzzy set member is multiplied by the degree in that member, the products summed, and the sum divided by the sum of the MDs. Options for choice of representative value are the method of average maximal (max), and the centroid method. Alternatively, rule may be written to implement almost any desired defuzzification scheme. As for fuzzifying numbers when defuzzification is to take place, MFs for the *input fuzzy* set should usually be peaked and intersecting at half full confidence.

There are different methods in order to obtain a single number as output result. Since there is not any procedural method to chose which method is more suitable, most common used ones are middle of maximum, centroid, largest of maximum. After the final result, as an irregular shape as in Figure 6.17, the final step in the approximate reasoning algorithm is *defuzzification*, i.e., choosing one crisp value for the output variable. Fuzzy reasoning algorithm by the use of Mamdani model (Mumdani, 1974) leads to an output fuzzy set with particular MDs of possible numerical values of the output variable. Defuzzification compresses this information as an output value.

In most of the applications, it is advised that the hydrologist should look at the MDs of individual variable values, and choose one of them according to the following criteria; ‘the smallest maximal value’, the largest maximal value’, ‘center of gravity’, ‘mean of the range of maximal values, etc. He can even make his own preference according to the problem at hand. For instance, in cases of drought studies the minimal portion of the final fuzzy set may be adopted. The output of approximate reasoning in Figure 6.17 will have in sequence of increasing magnitude the defuzzification result as ‘smallest of maximum’, ‘mean of maximum’, ‘center of gravity’, and ‘largest of maximum’ as in the following figure.

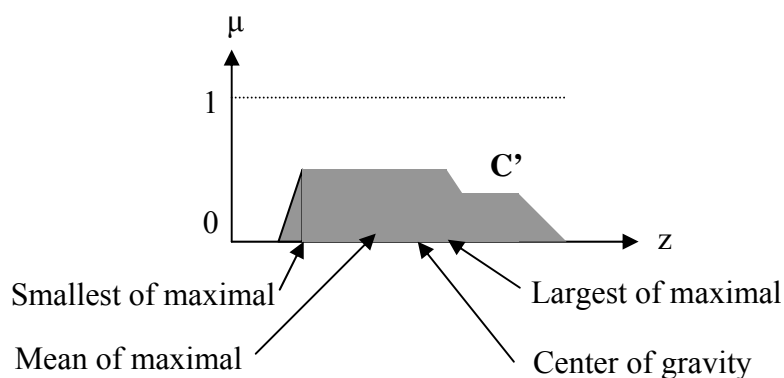

Figure 6.17 Defuzzification of max-min composition

Defuzzification causes a great deal of information loss. Therefore, in any hydrologic design it is recommended that the hydrologist take into consideration some other features of the final composition fuzzy set in addition to formal defuzzification methods as in Figure 6.18. In classical expert systems rules are exclusively obtained from human experts. However, in Fuzzy rule-based systems, the rule formation are also made by human experts in addition to numerical data also the expert view of the human specialist. The combination of numerical data recorded by instruments and linguistic information elicited by experts is possible through fuzzy concepts and systems.

Fuzzy model development requires several iterations where the first step defines the set of rules and the corresponding input and output MFs. After the model execution the results are compared with already available output data and accordingly either the MFs or rules or both are revised by necessary adjustments, if necessary. Then in sequence, the model is tested once again with the modified rules and/or MF, and so on. It is possible to divide the model construction procedure into two successive parts, namely, training and prediction. In the training phase the previously mentioned MF or rule-base modifications are completed. In the prediction phase, the output values are cross-validated with the available data portion, and if necessary, again MF or rule-base or both adjustments are applied. FL expert systems may not even require data for the model construction including MF allocations and rule-base formulation. This stage is known as completely logical and *expert view* phase. In short the model development can be summarized as,

- 1) Expert information is used to construct the model structure with relevant input and output variables in addition to the rule-base. This step does not require any data and therefore it is called *logical phase* in model construction. This model must be checked with numerical data from relevant experiments,
- 2) Numerical data is considered in two parts as the *training* and *testing* portions. The available set of data can be divided heuristically into two portions. In hydrological studies it is advised in this book to take about 75 % as training and 25 testing data. In the training phase as mentioned above the MFs and the rule-bases are adjusted. In general, some of the rules are deleted because they may not be triggered by the available data;

some of the rules may be combined together if they result in similar outputs; and still others may be modified, and

- 3) In the testing part, the model *cross-validation* is observed with prediction errors. It is possible to further adjust MFs and the rule-bases on the basis

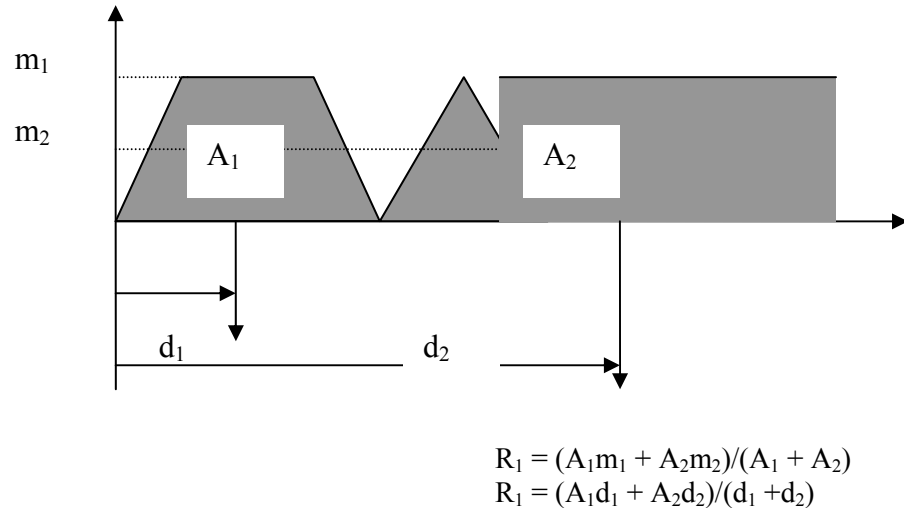

Figure 6.18 Weighted fuzzy defuzzification calculations

of error possible to further adjust MFs and the rule-bases on the basis of error minimization, for instance, by least squares procedure. If the total prediction error is less than 10 % or preferably than 5 % then the model is adopted for prediction where data are not available. Two different types of weighted average defuzzification procedures are shown in Figure 6.18. In the first one the membership degrees and in the next one the areas of each fuzzy subset are used as weights.

6.8.3.7 Fuzzy Application to Seepage Prediction

6.8.3.7.1 Model LAQ-SP

In order to develop the fuzzy model for seepage prediction, the length, wetted area and discharge constitute the antecedent variables with 4, 4 and 4 fuzzy subsets, respectively. This implies in general that there are $4 \times 4 \times 4 = 64$ rules. Hence, some of 64 rules will have the same consequent fuzzy subsets. The consequent part of fuzzy subsets of seepage is allocated according to expert view by the researcher and some other specialist in the study topic. Their consensus views are taken as final decision in the establishment of fuzzy rule on the consequent parts under the light of 64

different alternatives in the antecedent part with three variables. Out of 64 rules, 17 rules are selected as logical rules as tabulated in Table 6.6. Hence prior to actual data usage, the fuzzy system model is obtained as a collection of IF-THEN rules. Such a fuzzy system is very flexible and can digest the imprecise type of information.

Table 6.4 Logical rules for LAQ-Sp fuzzy model

If “L” is	And “A” is	And “Q” Then	“Sp” is
VL	VL	VL	M
H	M	M	VL
H	H	H	M
VL	VL	VL	H
L	VL	VL	M
VL	VL	VL	H
VL	VL	VL	H
VL	VL	L	L
M	L	L	M
H	H	H	L
H	M	H	L
M	L	L	H
VL	VL	VL	M
M	M	M	M
L	L	L	M
H	M	M	M
H	H	H	M

In Table A-10, 1st, 2nd and 3rd columns include the input observed data and 4th column contain corresponding output observed data. Also 5th, 6th and 7th columns include the combinations of input variables (antecedent part) fuzzy subsets and 8th column exposes the corresponding fuzzy rule for the consequent part. The IF-THEN rules can be written from this table for each row by locating the fuzzy subsets in 5th, 6th and 7th columns with the corresponding fuzzy subset from the 8th column after THEN part of the rule as consequences.

Application of actual data to such a fuzzy system with 64 rules might not trigger some of these rules. Hence, these untriggered rules are not relevant for the seepage prediction and should be dismissed from further consideration. If there are significant and regression type of relationships between antecedent and consequent variables, then many of the rules will not be triggered. Otherwise, for very scattered data, almost all the rules will be triggered at different frequencies. The input observed data, triggered rules and output observed and predicted data are presented in Table A.10. Figure 6.10 shows high dispersion of data in the scatter diagrams between different input and output variables. Due to such high dispersion of data, it is not

possible to employ regression approach with restrictive assumptions as explained in the previous section 6.8.2.

However, fuzzy system approach is very suitable to deal with such scatter diagrams. The more the dispersion in the scatter diagrams, the more is the number of rules triggered. For this purpose, fuzzy rules are used with the antecedence variables, and subsequently, seepage predictions are presented in Table-6.9 for model LAQ-Sp (length, area, discharge and seepage by ponding method).

Model:- 1 LAQ-Sp

a) List of input Variables:

Length of canal	“L”
Wetted perimeter	“A”
Head Discharge	“Q”

b) List of output Variables

Seepage (ponding method)	“Sp”
--------------------------	------

c) Input Membership Functions

For each variable, MFs are selected in order to grasp the data. The MFs have their values on the horizontal axis. The variability domain of the variable concerned with the membership degree is on the vertical axis. In a way, fuzzy MFs are the transformers of data values to MDs (membership degree) or given MDs to data value. Such a transformation is referred to as the triggering or firing feature of the fuzzy rules.

1). Length of Canal

- VL: Very Low
- L : Low
- M : Medium
- H : High

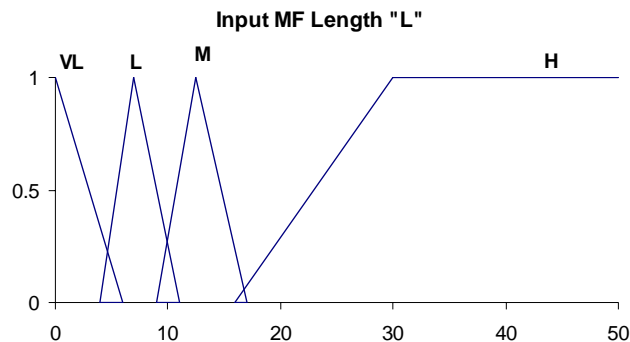
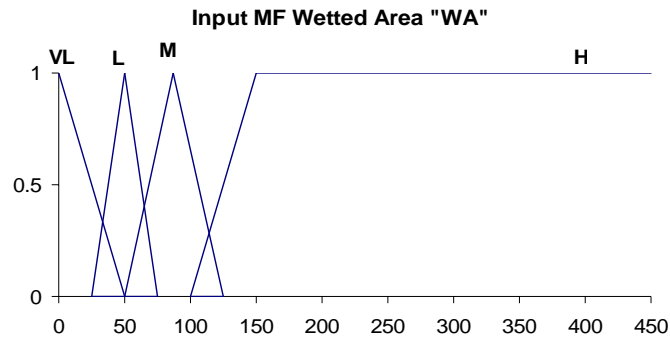

Figure 6.19 Membership functions for LAQ-Sp input variables

2). Wetted Perimeter

VL: Very Low
L : Low
M : Medium
H : High



3). Head Discharge:

VL: Very Low
L : Low
M : Medium
H : High

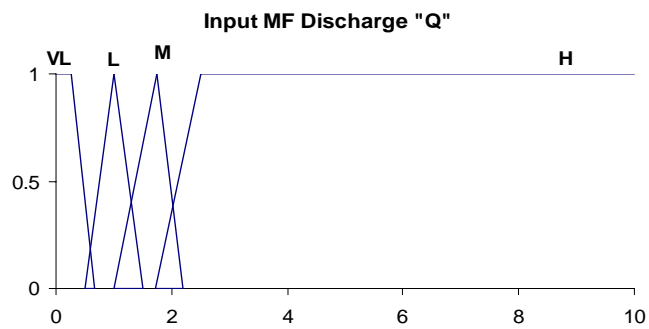

Continued figure 6.19 Membership functions for LAQ-Sp input variables

b) Output Membership Function

1. Seepage (Ponding method)

VL: Very Low
L : Low
M : Medium
H : High

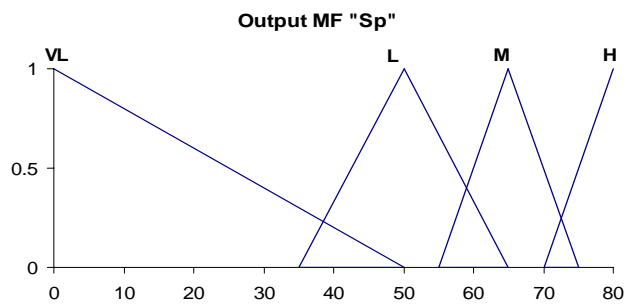

Figure 6.20 Membership function for model LAQ-Sp output variables

c) **Fuzzy logical rules**

The above fuzzy logical rules are put in the fuzzy inference engine along with MFs, output MFs are obtained and when these are defuzzified, at the end one can get the output results. Fuzzy model was run using the MATLAB programme and results are presented in tabular forms as in Table A.10.

6.8.3.7.2 Reliability of Fuzzy Model

In order to check the reliability of the model developed herein by using FESS project observed data, an independent seepage observed data is also obtained from the project. It is obvious that the measured and predicted seepage are very close to each other with less than 15%, 11% and 9.5% for three trials, respectively. This shows the validity of fuzzy rule set for seepage prediction provided that there are length, wetted area and discharge data from the canals.

Finally, Figure 6.21 shows observed versus predicted seepage fall around the 45° straight line with acceptably small variations. Since, the overall deviations from the straight-line for this model is less than 10%, the fuzzy models LAQ-Sp as presented in this thesis is acceptable for seepage prediction using ponding method from canals.

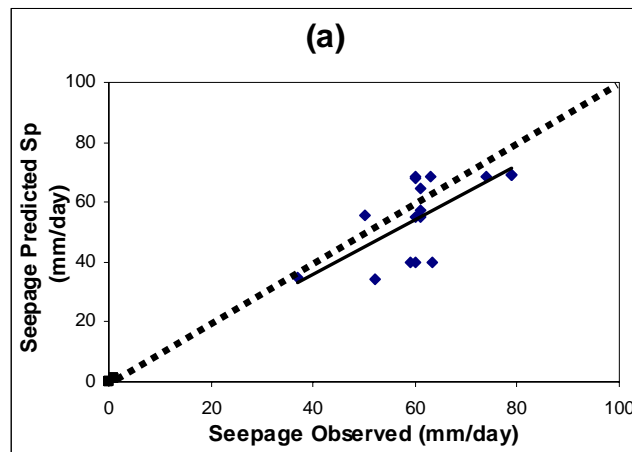

Figure 6.21 Graph between observed and predicted values for model LAQ-Sp

a) Trial #1,

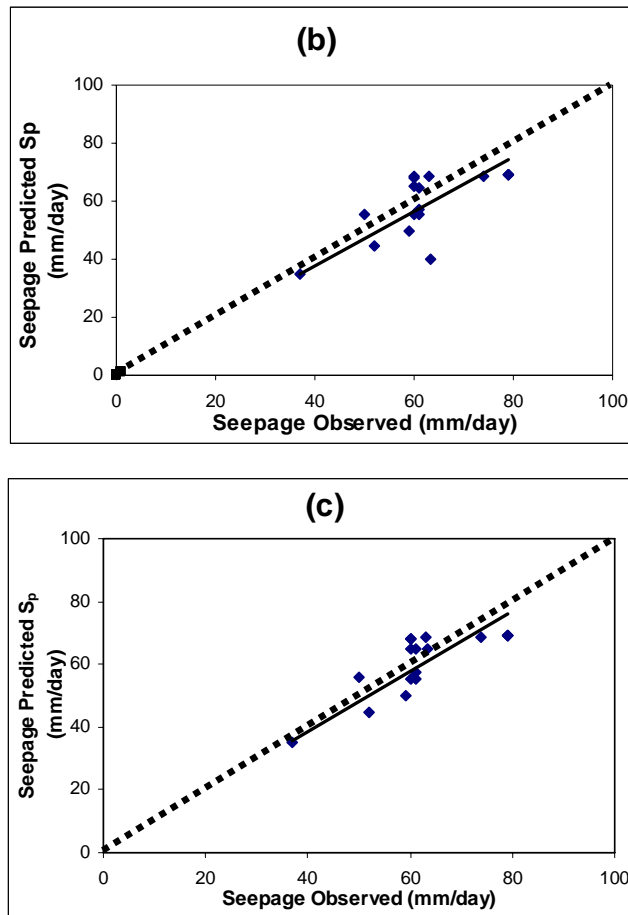

Figure 6.21 Graph between observed and predicted values for model LAQ-Sp
 b) Trial #2 and c) Trial # 3)

6.8.3.7.3 Fuzzy Model LAQ-Si

Another fuzzy mode is developed for seepage (inflow outflow) prediction using the length, wetted area and discharge as input variables. In this model length “L”, wetted perimeter “A” and discharge “Q” constitute the antecedent variables with 4, 4 and 4 fuzzy subsets, respectively. This implies in general that there are $4 \times 4 \times 4 = 64$ rules. Hence, some of 64 rules will have the same consequent fuzzy subsets. The consequent part of fuzzy subsets of seepage is allocated according to expert view by the researcher and some other specialist in the study topic. Their consensus views are taken as final decision in the establishment of fuzzy rule on the consequent parts under the light of 64 different alternatives in the antecedent part with three variables. Out of 64 rules, 17 rules are selected as logical rules as tabulated in Table 6.7. Hence, prior to actual data usage, the fuzzy system model is obtained as a collection of IF-THEN rules. Such a fuzzy system is very flexible and can digest the imprecise type of information.

Table 6.5 Logical rules for Fuzzy model LAQ-Si

If “L” is	And “A” is	And “Q” THEN	“Si” is
VL	VL	VL	M
H	M	M	M
H	H	H	M
VL	VL	VL	M
L	VL	VL	M
VL	VL	VL	L
VL	VL	VL	M
VL	VL	L	M
M	L	L	M
H	H	H	H
H	M	M	H
M	L	L	L
VL	VL	VL	M
M	M	M	H
L	VL	L	M
H	M	M	M
H	H	M	M

In Table A.11, 1st, 2nd and 3rd columns include the input observed data and 4th column contain corresponding output observed data. Also 5th, 6th and 7th columns include the combinations of input variables (antecedent part) fuzzy subsets and 8th column exposes the corresponding fuzzy rule for the consequent part. The IF-THEN rules can be written from this table for each row by locating the fuzzy subsets in 5th, 6th and 7th columns with the corresponding fuzzy subset from the 8th column after THEN part of the rule as consequences.

Application of actual data to such a fuzzy system with 64 rules might not trigger some of these rules. Hence, these untriggered rules are not relevant for the seepage prediction (inflow outflow) and should be dismissed from further consideration. If there are significant and regression type of relationships between antecedent and consequent variables, then many of the rules will not be triggered. Otherwise, for very scattered data, almost all the rules will be triggered at different frequencies. The input observed data, triggered rules and output observed and predicted data are presented in Table A.11.

However, fuzzy system approach is very suitable to deal with such scatter diagrams. The more the dispersion in the scatter diagrams, the more is the number of rules triggered. For this purpose, fuzzy rules are used with the antecedence variables, and

subsequently, seepage predictions are presented in Table 6.7 for model LAQ-Si (length, area, discharge and seepage by inflow outflow method).

Fuzzy Model LAQ-Si

a) List of Input Variables:

Length of canal	“L”
Wetted perimeter	“A”
Head Discharge	“Q”

b) List of Output Variables

Seepage (ponding method)	“Si”
--------------------------	------

c) Input Membership Functions

1. Length of Canal

- VL: Very Low
- L : Low
- M : Medium
- H : High

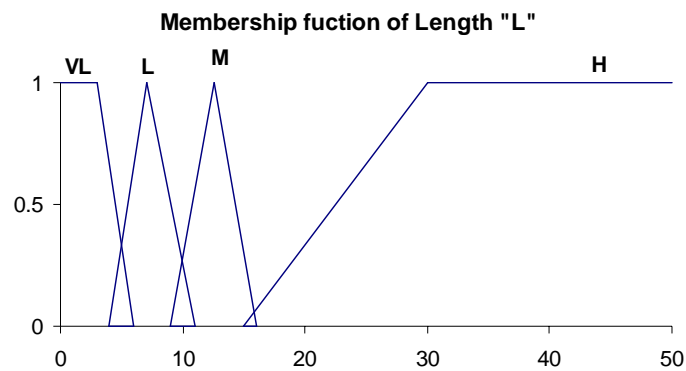

2. Wetted Perimeter

- VL: Very Low
- L : Low
- M : Medium
- H : High

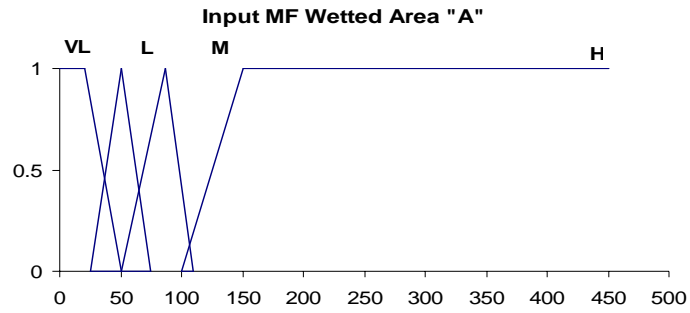

3. Head Discharge:

VL: Very Low

L : Low

M : Medium

H : High

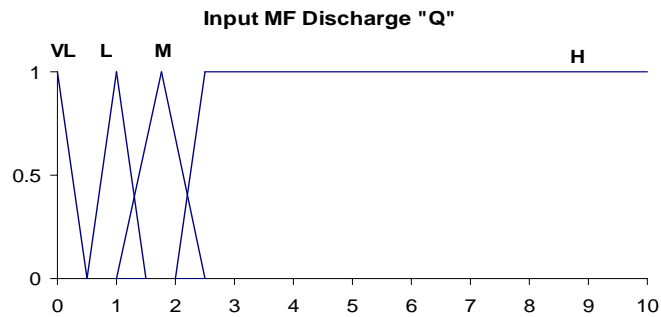

Figure 6.22 Fuzzy membership functions for model LAQ-Si input variables

d) Output Membership Function

1. Seepage (Ponding method)

VL: Very Low

L : Low

M : Medium

H : High

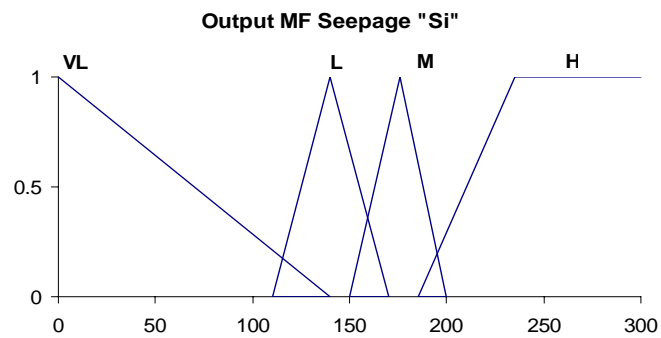

Figure 6.23 Fuzzy membership functions for model LAQ-Si output variables

e) Fuzzy logical rules and results

As presented in Table A.11

6.8.3.7.4 Reliability of Fuzzy Model

In order to check the reliability of the model developed herein by using FESS project observed data, an independent seepage observed data by inflow outflow is also obtained from the project. It is obvious that the measured and predicted seepage are very close to each other with less than 15%, 11% and 9.5% for three trials, respectively. This shows the validity of fuzzy rule set for seepage prediction provided that there are length, wetted area and discharge data from the canals.

Finally, Figure 6.24 shows observed versus predicted seepage fall around the 45° straight line with acceptably small variations. Since, the overall deviations from the straight-line for this model is less than 10%, the fuzzy models LAQ-Si as presented in this thesis is acceptable for seepage prediction using inflow outflow method from canals.

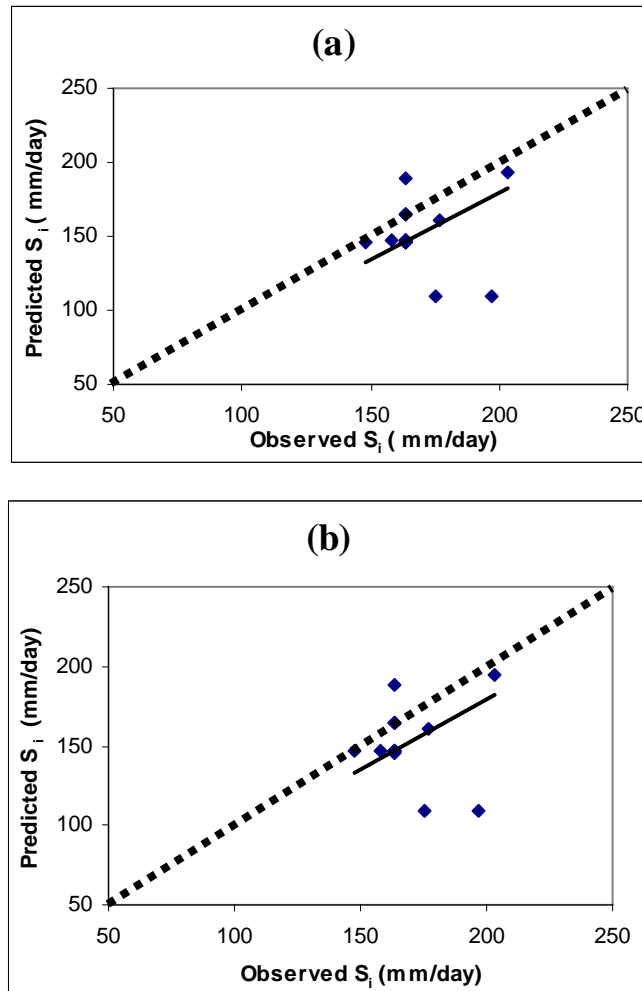
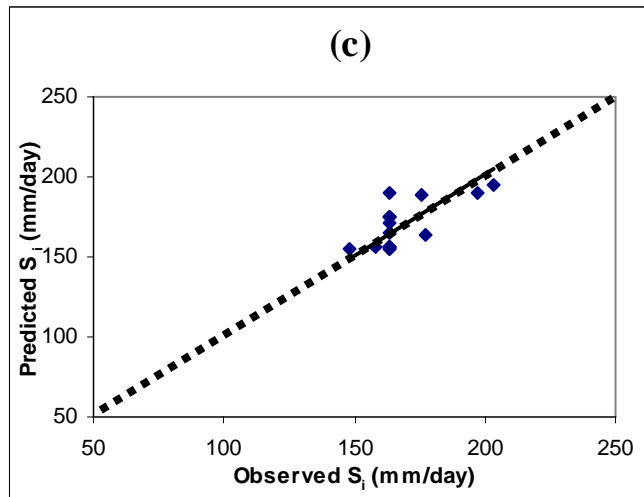

Figure 6.24 Observed and Predicted Seepage (In-Outflow) for Model LAQ-Si for
a) Trail 1 b) Trial 2



Continued Figure 6.24 Observed and Predicted Seepage (In-Outflow) for Model LAQ-Si for c) Trial 3

7. SEEPAGE CONTROL MATERIALS

Many conventional materials like cement concrete, bricks and tiles have been used for lining of canals to minimise the seepage losses. Asphalt, because of its waterproofing properties, and low cost has also been prominent among materials investigated for water harvesting and seepage control. Some in-situ experiments must also be done on these geomembranes under different field conditions in order to analyse the seepage control effectiveness. Geosynthetics is one of the materials used in canals for controlling the seepage from the canals. The word geosynthetics consists of geomembrane and geotextile. used in the canals in combination or used in combination with different material separately. In FESS project, the most of the production lining consists of combination of both materials. In experimental lining, these two materials are used collective or separately in combination with different other materials in order to select the most suitable one for seepage control.

In order to check the quality of geomembrane, experimental work (physical and mechanical tests) needs to be done according to ASTM standard to check the properties of materials. Since, there are several different standard tests for same geomembrane, especially, puncture resistance and tensile tests etc. The main objective requires the use of different tests so as to establish correlations or other relationships between them whatever possible.

7.1 Results of Testing of Geomembrane

About 40 geomembranes (including the four composites that have geotextile layers on each side of central geomembrane layer) have been tested by means of most of the test listed in the previous chapter. In some cases, it was impossible to do all tests because the sample obtained was not big enough. This affected particularly the hydrostatic cone test which needs large test pieces. Several materials were tested for seam strength because it was not possible to seam them with the available e

equipment, or because the sample was too small. Under each test, the table gives the results of tests on two to five test pieces, usually three, and the average or minimum for comparison with other materials. Normally the average is used, but in the case of the dumbbell tensile test and greaves tear test, the parameter used for summarising the results is the minimum instead. This is because the results of these tests depend on the direction in which the test piece is cut from the sample, relative to the manufacturing direction, and it was not possible to ensure equal numbers of test pieces in two orthogonal directions. The weaker direction is considered critical and more relevant characteristic than that for other other direction.

In order to make the analysis and discussion of these results manageable, they have been summarised in Table A.12, which presents only average or minima For analysis purposes, only minimum values are considered as it is critical from strength point of view. Composite materials and textured material is omitted for the following reasons,

- The composite geomembranes are small in quantity so the whole tests can not be performed on it, and
- The textured geomembrane is the only material of different type from others.

7.2 Data Analysis Techniques

7.2.1 Classical Regression Technique

Different statistical parameters such as mean, mode, correlation coefficient, and standard deviation are computed to check the true picture of data. These are presented in Table A.13. In this table T, A, B, C, N, F, G, H, and K represent the physical and mechanical test variables.

7.2.1.1 Regression straight line parameter estimation

Scatter diagrams between different variables are drawn in order to check the correlation between the variables. In this procedure, one variable is selected as independent and all others are as dependent. The scatter plots behaviour is checked to view some definite relation. The one that gives the straight line is selected as model otherwise some fitting techniques are adopted to get the correlation between the variables. Same procedure is adopted for all other variables. The scatter diagrams between variables are presented in the Figure A.1 to A.36 in the Appendix. From the

scatter diagrams, it is clear that some variables give definite relationships while others indicate some grouping within or outside the grouping band. In order to determine the parameter estimation, the comparison between the test methods is discussed in the next section.

7.2.1.2 Comparison of geomembrane test methods

One of the objectives of the programme was to examine some of the available test methods in order to improve ways of comparing geomembranes and writing geomembranes specifications for the canal lining projects. Historically, different tests have been tended to be used for different sort of geomembranes, depending on the manufacturers preferences and national or regional habits, on the development history of the geomembrane types, or on perceived disadvantages of some tests for some materials. This has made it difficult for designers and specifiers to compare the relevant performance behaviour of different geomembrane types. This section uses the 36 graphs in Figure A.1 to A.36 in the Appendix to search for useful conclusions about the test methods. Table 7.1 provides a key to the numbering of the figures in relation to the test methods.

Table 7.1 Key to graph numbers for graphs comparing geomembrane test methods

KEY TO GRAPH NUMBERS	Relative Stiffness, RS	Tapered Probe Puncture, A	8 mm Puncture, B	Pyramid / water Puncture, C	Pyramid / Aluminium Puncture, D	Cone Height, N	Tensile Strength, F	Tear Strength, I
Thickness, T	A.1	A.2	A.3	A.4	A.5	A.6	A.7	A.8
Relative Stiffness, RS		A.9	A.10	A.11	A.12	A.13	A.14	A.15
Tapered Probe Puncture, A			A.16	A.17	A.18	A.19	A.20	A.21
8 mm Puncture, B				A.22	A.23	A.24	A.25	A.26
Pyramid / water Puncture, C					A.27	A.28	A.29	A.30
Pyramid / Aluminium Puncture, D						A.31	A.32	A.33
Cone Height, N							A.34	A.35
Tensile Strength, F								A.36

The various tests are now discussed in turn. When two tests give highly correlated results there is at least a suspicion that they are measuring approximately the same property by different means. So that to use both of them in a specification or a comparison between materials may represent a duplication of information. If on the other hand, two tests show little or no correlation, or very different grouping of particular types of materials then the information given by the two tests does not overlap to the same extent, and it may be more appropriate to use both of them. The composite materials are ignored in some sections of the discussion, since they are rare type with little field use.

7.2.1.3 Tensile Strength

The result of the dumbbell tensile test is conventionally reported as the maximum force reached, through more information is given if the extension at break is quoted or the force-extension curve is shown as in Figure 7.1. In many respects the maximum force for a yielding material like HDPE (High Density Polyethylene) is of little significance, because the yielding force, often much lower, is usually the limit on the material's useful strength (once the yield has begun at one place, more and more material will yield at a lower

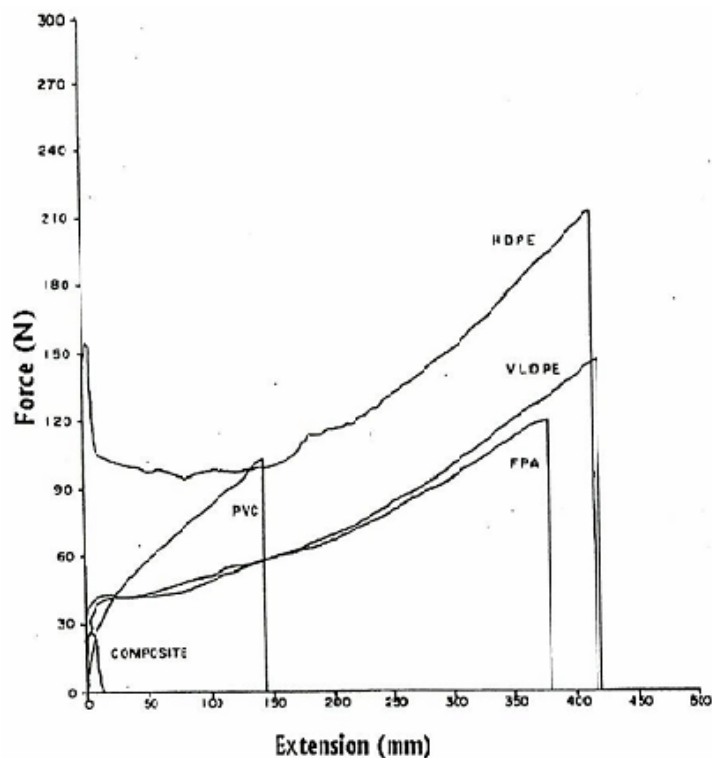

Figure 7.1 Behaviour of different materials under tensile strength test (Direct testing machine output)

force, as shown by the wide plateau after the yield point, and the material beyond the yielding zone will not contribute to surviving a puncturing or tearing force). A more fundamental advantage of tensile test is that they do not directly match the common mechanism of geomembrane failure, which are tearing and puncturing. Another is that results depend on the direction a test piece is cut, in relation to the machine direction at the time of manufacture, which is not of much relevance to the field loading. Figure A.7 shows tensile strength relative to thickness. Overall there is a wide spread, but the ordinary unreinforced semicrystalline geomembrane, mainly polyethylenes, polythylenes and PVC, all lie in a fairly narrow band on the graph, meaning that tensile strength is strongly related to the thickness within this group. For a given thickness, the very flexible elastomers (EPDM and Mizu) shows lower tensile strength by a factor of two or three. Figure A.36 shows tensile strength to be closely related to tear resistance for almost all materials, meaning that information from these two tests is largely overlapping. Figure A.14, on the other hand, shows that tensile strength is not strongly correlated with relative stiffness.

The relationship of the tensile strength to puncture resistance is shown by the remaining five graphs that involve the tensile parameter. Figure A.25 shows that tensile strength is closely related to the 8 mm cylinder puncture test. This appears to be because the 8mm cylinder has a fairly blunt end and most geomembranes stretch a long way (probe movements of 30 to 50 through a test piece of radius only 22.5 mm), so the test is more of a two-directional tensile test than a true puncture test. Even so, there are systematic differences between the tests for different material types. In particular, reinforced geomembranes show relatively better in 8 mm cylinder puncture than in the tensile strength test. A fairly similar picture is seen with the tapered probe puncture test in Figure A.20, but the spread is wide so the overlap of information between the two tests is less. There are signs that very stiff geomembranes like HDPE show relatively well on the tensile test, while intermediate and flexible ones like VLDPEs and FPAs shows better in the tapered probe puncture test.

Turning to the two pyramid-probe tests, the correlation with the tensile test becomes much weaker. Figure A.29 shows some correlation between the tensile test and the pyramid-over-water puncture test, but the spread is wide and there is significant grouping as described in the graph's text box. In the case of the pyramid-over-aluminium puncture test, the spread in Figure A.32 is even wider.

Finally, Figure A.34 shows that critical cone height and tensile strength are almost totally unrelated, except insofar as they are both related to stiffness. Thus tensile strength is not clearly separate property, but closely related to tear resistance and to some puncture tests, especially those with blunt probes like the 8 mm cylinder puncture test. Tensile test result also tends to be somewhat variable.

7.2.1.4 Tear Resistance

The close correlation between tear resistance and tensile strength, as shown by the Figure 7.36, has already been mentioned. It is, therefore, not surprising that Figure A.6 shows that tear resistance, as measured by the Graves tear test is closely correlated with the thickness for the semi crystalline geomembranes, as for tensile strength. Figure A.15 shows a much weaker correlation between tear resistance and relative stiffness.

As regards the five kinds of puncture test, Figure A.21 and Figure A.30 shows weak relationships between tear resistance and the tapered probe and the pyramid-over-water puncture tests, but Figure A.33 shows rather more correlation with a pyramid-over-water puncture test and Figure 7.32 shows quite a strong link between tear resistance and the 8 mm cylinder puncture test. Like tensile strength, tear resistance appears not to be closely related to critical cone height (Figure A.35). Tear resistance is not entirely a separate property, but it does show significant information, independent of other test, for some types of materials, especially the less common one like composites and reinforced geomembranes.

7.2.1.5 Tapered Probe and 8mm Cylinder Puncture Tests

Observation of these tests, especially on the more flexible and extensible geomembranes, raises the concept that they are in many ways acting as tests without the directional problems of the strip and dumbbell tensile test. Both the probe shapes are blunt enough that such geomembranes stretch a long way before puncturing occurs, and the material effectively fails in tension in the deep cone which the plunger forms. In the tapered probe puncture test, Figure 7.2 shows how such geomembranes survive plunger forms in 20 to 40 mm, in a test circle of radius of only 13 mm. In the 8 mm cylinder puncture test the displacements at failure range from 25 to 45 mm as shown in Figure 7.3 with an unsupported sample radius of 22.5 mm.

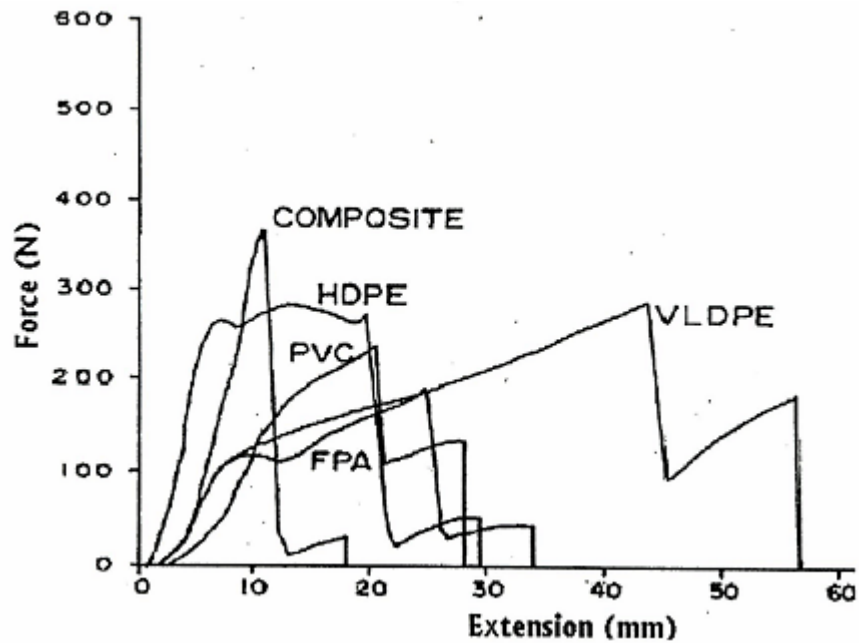

Figure 7.2 Behaviour of different materials under tapered probe slow puncture test (Direct testing machine output)

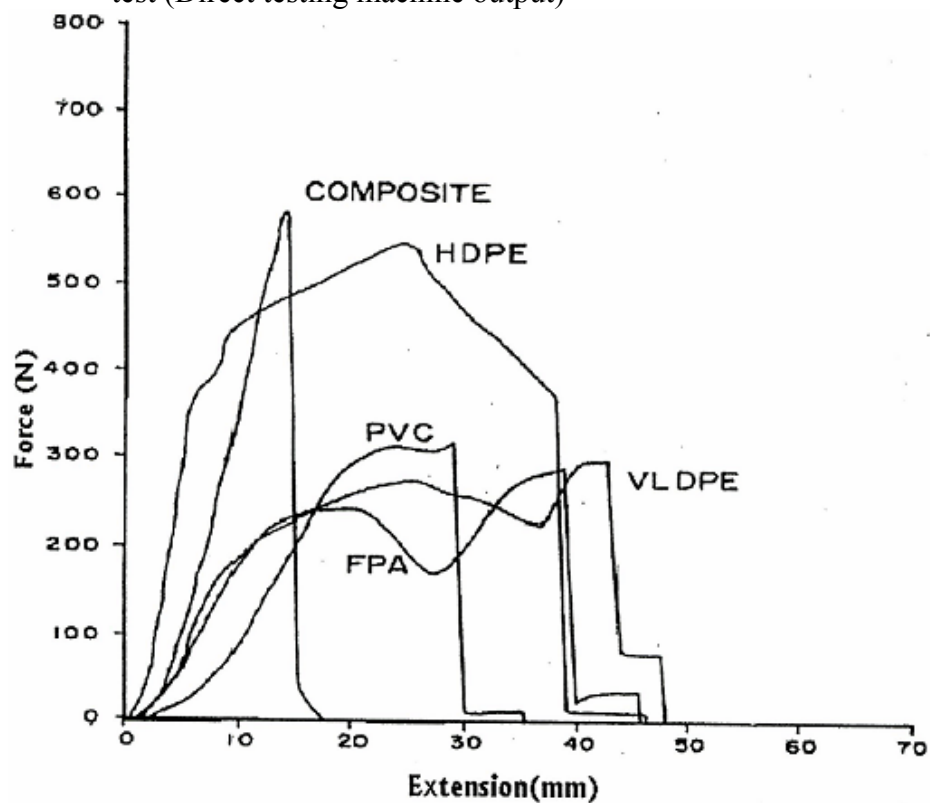

Figure 7.3 Behaviour of different materials under 8 mm probe slow puncture test (Direct testing machine output)

The correlations with the dumbbell tensile strength test results are, however, not very marked, so one cannot conclude that either of these so-called puncture tests could simply replace the traditional tensile test (quite apart from the fact that the tensile test

is much quicker and easier to perform even allowing for the need to cut test pieces in two directions). Of the two, the 8mm cylinder puncture test is closer to the tensile strength test than the tapered probe puncture test is (Figures A.20 and A.25). Looking at tear resistance results in Figures A.21 and 7.32, we again see the higher correlation with the 8mm cylinder puncture test. In fact the correlation between the puncture test and the tear test in Figure A.26 is one of the highest seen in the whole set of graphs. Obviously, both Grave tear and 8 mm cylinder puncture are related to tensile properties, but in the subtle ways that make a quite difference, especially with the less common materials like composites and very flexible geomembranes, both of which are relatively favoured by the puncture tests.

Neither of these puncture tests is closely related to relative stiffness (Figures A.19 and A.10), though again the 8 mm cylinder puncture test shows more linkage than the tapered probe puncture tests. Figure A.16 shows the relationship of these two tests to each other. There is a considerable correlation for all material types, even composites, which underlines the similarities between the two tests. However, there is also some system to the dispersion between results, the tapered probe puncture test tending to favour the more flexible ones. So neither test makes the other one's information entirely redundant.

The pyramid tests are discussed below. Figures A.19 and A.24 show little correlation with critical cone height, except the usual indication that higher breaking forces in any tests related to tensile behaviour tends to go with low critical cone height.

In summary, both these blunt-tests are related to tensile strength and tear resistance, but there remain significant differences with both those tests and between the two puncture tests. Of the two, the tapered probe puncture test seems to have less overlap with other tests than the 8 mm cylinder puncture test does.

7.2.1.6 Pyramid-Over-water Puncture Test

This test is of particular interest because it has a much sharper probe than the two discussed above, and thus appears to be more directly related to the true puncturing in field conditions. Another significant difference is that the pyramid-over-water puncture test uses an electrical circuit to define the moment of puncturing and to relate the maximum force to that moment. The differences can be seen clearly by comparing the force-displacement curves for five materials, in Figure 7.4, with the corresponding curves for the other tests in the Figures 7.2 and 7.3. In the latter two

caes, especially the tapered probe one, the test continues after puncturing and the test piece tends to develop considerable force by clinging to the sides of the probe. For some materials, the failure is not clearly defined, with multiple peaks and notable slope changes. With the pyramid-over-water puncture test there are still multiple peaks for VLDPE and FPA, but the first peak is higher one and defines the maximum force, which is the parameter used for comparison in later graphs.

Figure 7.4 also provides a particularly clear illustration for the differences in extensibility, represented by the relative slopes in the early part of each force-displacement curve despite the slightly different thickness the curves are clearly in order of relative stiffness.

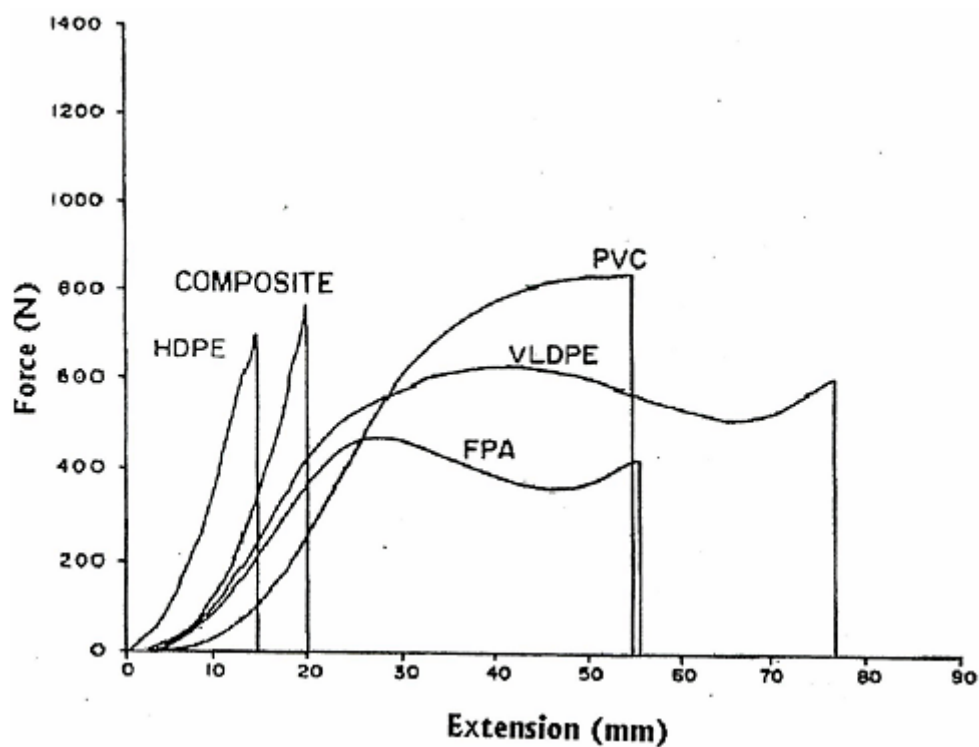

Figure 7.4 Behaviour of different materials under pyramid over water (Direct testing machine output)

The pyramid-over-water puncture test is not only correlated with any other test, which confirms its nature as a measure of a distinct property. The graphs against Relative stiffness and critical cone height Figures A.11 and A.28 show that these properties are mostly independent of pyramid-over-water puncture resistance, except for a slight tendency for very flexible (and therefore very extensible) geomembranes to show high resistance to this sort of puncture as well as a high critical cone height. Similarly, pyramid-over-water puncture test results are only slightly correlated with thickness, tensile strength and the tear resistance Figures A.14, A.29 and A.30, which

three properties have already been seen to be closely related to each other, and with the blunt-probe puncture tests in Figures A.17 and A.22. There is, however, systematic grouping of some material types. The composites show particularly badly on the pyramid-over-water puncture test, probably because the geotextile layers can contribute to tensile and tear performance, and to puncture resistance with the blunt probe shapes, are easily penetrated by the sharp pyramid probe. Again the very flexible geomembranes show better in pyramid-over-water puncture test than in the tensile, tear or other puncture tests. The 8 mm cylinder puncture test shows slightly more linkage to the pyramid-over-water puncture test than the other do. All these observations confirm that pyramid-over-water puncture test measures a distinct material property, possibly because of its sharp probe and its ability to mobilise the benefits of flexibility and extensibility in the resistance of real puncturing forces.

7.2.1.7 Pyramid Over Aluminium Puncture Test

Despite using the same probe, this is very different test from the pyramid-over-water one, as evidenced primarily by the Figure A.27 which compares them directly. It does not favour the very flexible geomembranes, but the composites show quite good resistance the opposite to the test over water. This comparison separates the effects of the probe shape from those of probe movement, since in this test, the probe moves only a millimeter or two before penetrating the geomembrane and making electrical contact with the aluminium. None of these tests can be seen as real puncture test rather than Proxy tensile tests, because of the shape of the probe. Figure 7.5 shows the behaviour of different material failure.

The test over aluminium simulates a field condition where a geomembrane overlies a fairly hard and unyielding subgrade. It shares with the pyramid-over-water puncture test the advantage of having a clearly defined moment of puncturing. The results of the pyramid-over-aluminium test show significant correlation with those of the tear test in Figures A.33, and less with the two blunt-probe puncture test in Figures A.18, A.23 and A.32. It tends to favour the stiffer geomembranes, and this is shown again in the Figure A.31 against critical cone height where such materials show high resistance despite their low critical cone height. Tensile or elastic properties obviously play a part in resisting the pyramid-over-aluminium puncture test's sort of puncturing, but it remains a distinct property. The relationships with thickness and relative stiffness are not of particular interest.

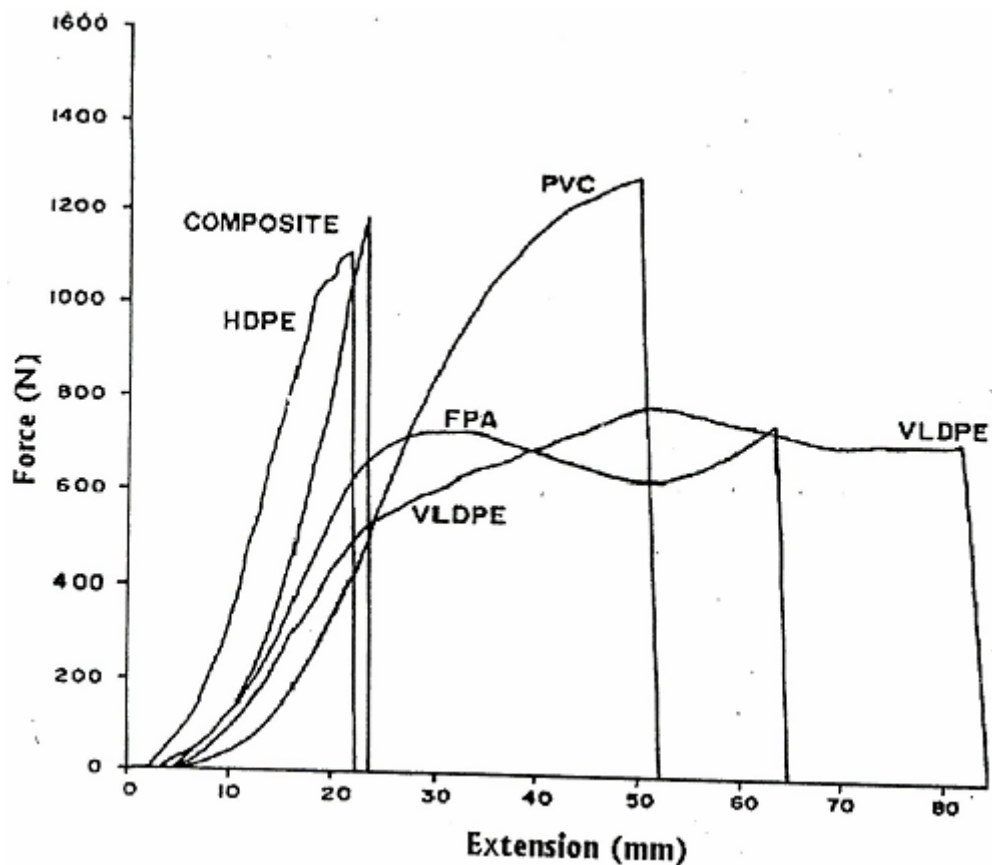

Figure 7.5 Behaviour of different materials under pyramid over aluminium (Direct testing machine output)

7.2.1.8 Hydrostatic Cone Test and Critical Cone Height

The above discussion of the above tests have already remarked on the fact that critical cone height is a very different sort of property from the rest, resulting obviously from the nature of the test as one that directly simulates the interaction of subgrade support and geomembranes extensibility in resting puncturing. None of the eight relevant graphs shows the sort of correlation that enables one to define a band within which most of the points lie. Probably the most striking relationship is that with relative stiffness, Figure A.13 shows how, among the materials that happened to be tested for this programme, all the stiff and very stiff ones had critical cone height worse than 20 mm. All the flexible and very flexible ones had critical cone heights better than 40 mm, and the intermediate-stiffness materials had a wide mixture of critical cone heights, from almost nothing to almost 70 mm. Unlike other tests that favour the “very flexible” materials like elastomers and PVC, this test also favours the “flexible” ones, the FPAs (Flexible poly alloys). Other properties are related to

stiffness and they are of course also slightly related to critical cone height, as noted in Figures A.24, A.34 and A.35, but there is a notable lack of any discernible relationship with the tapered probe puncture test and the pyramis-over-water puncture test in Figures A.19 and A.28. Alone among the strength and damage-resistance properties, critical cone height even appears to be independant of thickness (see Figure A.6).

7.2.1.9 General Remarks on the Tests

There are two tests which seem to be largely independant of tensile properties and able to bring out the value of extensibility and flexibility in resisting puncture. The critical cone height test does so very directly in addition to the pyramis-over-water puncture test. The other tensile and damage-resistance tests and properties are significantly interrelated among themselves, apparently because they are all in some way measures of tensile or elastic properties. The most distinctive of these is probably the pyramid over aluminium test, which simulates a sharp object pressing a geomembrane against a hard subgrade whereas the pyramid-over-water and critical cone height tests simulate a sharp object pressing against a geomembrane without significant support from the other side. The two older puncture tests, with their blunter probes, are not quite equivalent to two-dimensional tensile tests, though they are largely measuring tesile behaviour, and this makes their results less easy to relate to real field conditions than the more modern pyramid tests. No two tests are so closely correlated as to make the information from one redundant when one has information from the other. Some of the differences between puncture tests may be due to their very different plunger movement speeds, the pyramid-over-water puncture test is done at only 50 mm/min while the 8 mm cylinder test is done at 300 mm/minute and the tapered probe one at 500 or 508 mm/minute (see Figures 7.4 and 7.5). In order to define most of the important properties of a geomembrane or competing material the following basic sets of tests would be needed, since they generally describe distinct sorts of geomembranes property.

- Thickness is the most basic and easily measured geomembrane property,
- The stiffness test is an indicator of the property that affects ease of handling,
- The hydostaic cone test (giving critical cone height), is a simulation of the material's ability to deform and mobilise support from its subgrade to

help resist a puncturing force (or alternatively to resist puncturing by means of its own brute strength, though even thick HDPEs can hardly do this at the high water pressure),

- The pyramid-over-water puncture test simulates a sharp puncturing object resisted without subgrade support.
- The pyramid over aluminium puncture test simulates a sharp puncturing object pressing the geomembrane against a hard subgrade, and
- One or more of the remaining tests: the tapered probe puncture test, the 8 mm cylinder puncture test or the tear test.

This is of course a subjective list, and each designer or specifier will be interested in particular properties for a particular application. For instance, if the area to be lined is flat, wide and long, and the geomembrane can be rolled out and welded entirely on site, without folding up prefabricated panels for transport, then stiffness is not such a disadvantage as it is for the lining of a narrow canal. In some applications one type of puncturing may be more of a threat than others. For canal lining the order of importance is probably approximately the order of the above list.

There is possibility to use not only the maximum force recorded by the tension-compression machine. As has been done in Figures A.1 to A.36, but also the force-displacement information revealed by the curves like the sample presented in Figures 7.1 to 7.5. The principle would be to stimulate the subgrade's contribution to resisting puncturing of a geomembrane, not physically in the test procedure but mathematically in the interpretation of the result. The simplest way to do this would be to idealise the subgrade reaction by a purely elastic reaction $R = kd$, where R is the force with which the subgrade resists penetration of a puncturing object acting through a geomembrane, k is an elastic constant particular to that subgrade and the shape of the puncturing object, and finally d is the displacement of the puncturing object into the geomembrane-subgrade system. One could then simplifying the situation again, say that the force, F , applied by the puncturing object, one part R is resisted by the subgrade and another part $F-R$ is resisted by the geomembrane. This imputed force $F-R$ or $F-kd$ can be measured as a property of any geomembrane, if the puncturing object is one of the standard puncture test probes. This would in effect use more information from the force-displacement curve than has been done up to now, while still resulting in a single numerical parameter. Although the geosynthetics testing programme described in the thesis has provided some data for the later

development of this concept, time has not permitted any significant progress on its use for either describing or specifying geomembranes.

7.2.2 New Analysis Technique Using Grouping of Data

From the above classical regression, it is clear that due to certain limitation, the good relation between the variables can be developed as the data consisted of a variety of materials like HDPE, VLDPE, PVC, reinforced and composite. In order to solve this problem, a new technique has been developed using a new variable i.e. relative stiffness, RS taking into consideration of thickness and flexibility. By computing this variable, the whole data can be divided into groups and each group has certain boundary and identity.

7.2.2.1 New Variable

To provide some framework for analysing differences in physical behaviour, the 36 materials were first categorised in terms of stiffness. Figure 7.6 plots their overhang lengths in the stiffness test against their thickness. It was found by inspection that they fall into bands separated by the lines at a slope of 150 mm of overhang per mm of thickness, and this was used to develop a simple parameter called relative stiffness or RS which is defined under the text box under the figure as $L-150t$, where L is the overhang length and t is the thickness. This served to give a crude index of stiffness independent of thickness, i.e. as property of a particular type of geomembrane like HDPE or FPA. This index is the basis of five different stiffness groups used in Table 7.2 and is discussed below.

Close inspection of the Table 7.2 and Figure 7.6 reveals that there is a wide gap between the "very stiff" materials and the "stiff" ones (no RS value between 142 to 197 mm) and another gap between the "very flexible" and "flexible" ones (no RS value material between 411 and -23), but there are no such gaps between the center three categories. This may be merely a consequence of the limited number of material used for this research programme. It can be seen that RS is very closely related to modulus of elasticity, represented by the initial slope of tensile and puncture test graphs in Figures 7.1 to 7.5 materials like HDPE that have steep curves and tensile yield points are stiff, while those with gentle and smooth curves are flexible. All these properties are strongly related to the crystallinity of the geomembrane materials. i.e

the proportions of various polymers which are ordered as highly linear molecules. It seems that materials 161 and 171 labelled as Carbofol in the table are actually HDPE or something similar.

The remaining tests on unseamed geomembranes gave seven parameters for each material, which with thickness and relative stiffness makes nine properties. Figures A.2 to A.36 show graphically the relationship between the eight properties, so as to reveal meaningful correlations or grouping where ever possible. It must be remembered when considering these tables and graphs that there is a degree of random variation among test results and also the test are done in small laboratory whose staff has no prior experience of such task. Although the general trends are probably meaningful and significant, some variations may be the result of chance or of these local limitations.

7.2.2.2 Comparison of Geomembrane Materials Using New Variable

Many observations have already been made on the performance of particular types of geomembrane materials in particular tests, but this section brings together a few remarks, taking the main material groups in turn. It uses the grouping of Table 7.2, in terms of stiffness, but in a different order to facilitate discussion.

7.2.2.2.1 “Very Stiff” Geomembranes, HDPEs

The materials named as HDPE, and the carbofols which behave very similarly, are far stiffer than any other materials tested, after allowing for thickness by calculating the relative stiffness parameter $L-150t$. Most of them have relative stiffness values from 197 to 252 mm while one has a value of 142 mm and all other materials are below 140 mm. The text boxes under the graphs in Figures A.2 to A.36 include many remarks about performance of these materials relative to others. All these very stiff materials have critical cone height below 20 mm (see Figure A.13), and this is probably due to primarily to their marked yielding behaviour revealed most obviously in the tensile test cover for HDPE in Figure 7.1 once such a geomembrane has yielded over a sharp cone or probe, further strain takes place at a reduced stress and in a very localised manner, leading to local thinning and failure. In comparison between puncture tests the very stiff geomembranes tend to show good results in tests that do not involve sharp points, as instance in Figures A.16, A.20 and A.22, and more especially Figure 7.29 (The sharp puncture test is the pyramid over-water

puncture one, and the bulent (unshaped) one is the 8 mm cylinder puncture test, with tapered probe puncture test intermideate). On the other hand, these mateials do relatively well in the tear test, despite its stress concentration.

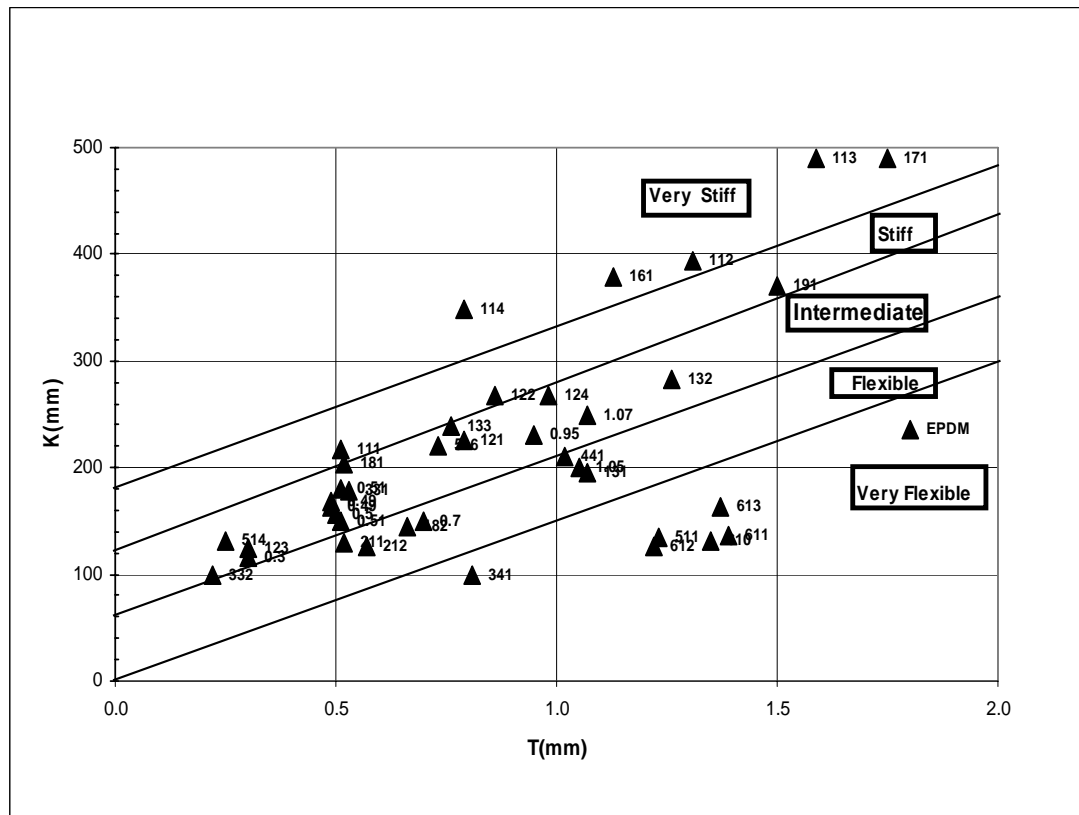

Figure 7.6 Graph between thickness and stiffness/fexibility

The relationship between overhang length in the stiffness test (K) and thickness (T) used to classify the geomembranes in terms of relative stiffness (RS), stiffness adjusted for thickness, which is defined as $L-150t$. The five catagories, which are relate to degree of crystallinity, are;

- Very stiff* : *RS more than 180 mm e.g. HDPE*
- Stiff* : *RS from 120 to 180 mm e.g. LDPE*
- Intermediate* : *RS from 60 to 120 mm e.g. VLDPE, VFPE, some LDPEs*
- Flexible* : *RS from 0 to 60 mm e.g. FPA*
- Very flexible* : *RS below zero e.g. rubber and other elastomers*

Although the very stiff geomembranes often lie along a line on the graphs, indicating strong corralation within the catagory, there is considerable spread in some cases. Material no. 112 is often out of line with the others. This permanantly reflects

differences in formation and manufacture between different materials within the class of HDPEs.

7.2.2.2.2 “Very Flexible” Materials

Results must be interpreted with caution here because the test programme included only three of these materials. Normally PVC, very thick EPDM of a type normally used for proofing applications, and proprietary reinforced material (mizu sheet). These materials, especially the EPDM and the mizu sheet do much better in tests with sharp probes or cones than they do in tests more related to tensile strength (see Appendix Figures A.13 and A.17). This reflects their ability to deform around a puncturing object without yielding at low strains like an HDPE.

7.2.2.2.3 Materials of “Intermediate” Stiffness

This group, according to the subdivision of materials in Table A.14, includes the VLDPEs, the more flexible LDPEs, and several materials that were not specifically labelled as belonging to any materials type “very flexible polyethylenes” or VFPEs, and some of the unlabelled ones are probably VLDPEs. Their extensibility often gives an advantage in tests with sharp probes or cones, as evidenced especially by Appendix Figure A.16. There is quite a bit of variability and some apparently anomalous results. The critical cone height in Appendix Figure A.13 ranges from below 10 mm to over 60 mm showing that there is considerable variety of properties within this group (though it may partly be merely a reflection of the fact that the test programme happened to contain more material in this group than in any other. Material no. 132 often shows anomalous results.

7.2.2.2.4 “Flexible” Material

This group contains all the FPA samples and one of the HDPE/LLDPE/LDPE mixtures from Xinjiang province in China (material 182). In most comparisons they lie between the “very flexible” and the “intermediate” materials, as one would expect. They do not show as well in the pyramid over water puncture tests as would expect from their relative stiffness, as seen especially in Figures A.11 and A.29 where they tend to be aligned with very stiff materials rather than between the very flexible and the intermediate cones. The tests in which they do particularly well is the hydrostatic cone test, where two of the three FPAs tested gave critical cone heights

over 75 mm, and the third 55 mm. Thus one of the two main sharp-puncturing tests favours the FPAs and the other does not.

7.2.2.2.5 “Stiff” Materials

In this category, there is fall of one of the HDPEs, two of the LPDEs and the second mixed PE materials from Xinjiang Province (no. 181). They do not appear to appear to have any distinctive properties as a group, being generally intermediate between the neighbouring groups.

7.2.2.2.6 Composite Material

These materials arrived on site from China, as samples submitted by unsuccessful tenderers for some of the lining contracts: Each comprises a thin and quite stiff clear geomembrane sandwiched between two layers of a fine non-woven geotextile, the three being firmly bonded together. The thickness of such material is not comparable to the thickness of a normal geomembrane, so the relative stiffness parameter was not computed for these four materials. (Table A.12 shows that their overhang length in the stiffness test was around 130 mm, similar to the thinner FPAs and relatively quite flexible). In the puncture tests, they tend to occupy extreme positions, especially in the pyramid over-water puncture test, where they showed consistent at very slow puncture resistance. As mentioned above this is probably because the probe was sharp enough to impose force mainly on the geomembrane layer, penetrating between the fibers of the geotextile layer. The resistance to the pyramid over aluminium puncture test was, however, quite high although it uses the same sharp probe. These materials are little known and used in western countries. They may have considerable advantages in some applications, if they can be seamed easily enough which was not investigated in this programme.

7.2.2.2.7 Strength of Geomembrane Seams

The test programme described in the previous section and the results given numerically in Table A.12, included the testing of geomembrane seams in shear and peeling modes, where ever the nature of the geomembrane and the size of the sample permitted it. The results should not be regarded as very significant, since the welding was done by the contractor `s staff on small samples so that they did not have much material on which to experiment and optimise the temperature, speed and wedge

pressure of the welding machine. Some samples were therefore probably not seamed as well as they might have been, especially the materials that the staff are not familiar with like PVC, EPDM, and the reinforced geomembrane (They had been working almost exclusively on VLDPE and FPA.) So the results must be interpreted with caution. They are plotted in Figures A.37 to A.41. Figure A.41 shows that for most of the geomembranes tested in this way, the peel strength was between 50% and 100% of the shear strength. The other four graphs plot the two kinds of seam strength against the results of the tensile tests and 8 mm cylinder puncture tests of the same materials (Since 8 mm cylinder puncture tests has been found to be the closest to a two dimensional tensile test). The four plots are similar and do not show any particularly remarkable features. In all cases, there is an evident and unsurprising correlation between the test on the plain gemembrane and the seam strength.

7.2.2.2.8 Regression Model Parameter Estimation using grouping

Scatter diagrams are drawn between different variables and relative stiffness to see the grouping of the data. From the scatter diagrams, it is clear that some variables give definite relationships while others indicates some grouping within or outside the grouping band. The brief summaries along with graphs are presented in Appendix from Figures A.9 to A.15. Let us see the regression model assumptions in order to check the reliability of the models.

7.2.3 Regression Assumptions

In the above regression models, the following assumptions must be checked for reliable regression parameter estimations. If anyone of these assumptions is not satisfied, it is necessary to transform the data in such a manner that after the transformation the assumptions are met. Otherwise, the regression model is not reliable due to the following points,

- a) Linearity assumption,
- b) Normality assumption,
- c) Average of the conditional distribution is equal to zero,
- d) Constant variance (homoscedascity),
- e) Serial dependence (Autocorrelation), and
- f) Measurements are error free.

a) **Linearity assumption**

In the regression equation explained above, the scatter diagram of the data is fit by a straight line. If the general trend does not appear in the form of a line, then whatever explained in the previous section for the regression model is not valid. For this reason, if scatter diagram does not imply by naked eye a straight line than the scatter diagram must be transformed into different forms for reaching to more or less a straight line. For instance, if a regression line is fitted to scatter diagram that does not imply linear trend, than as in Figure 7.7a the representation is not good. (Şen, 2003)

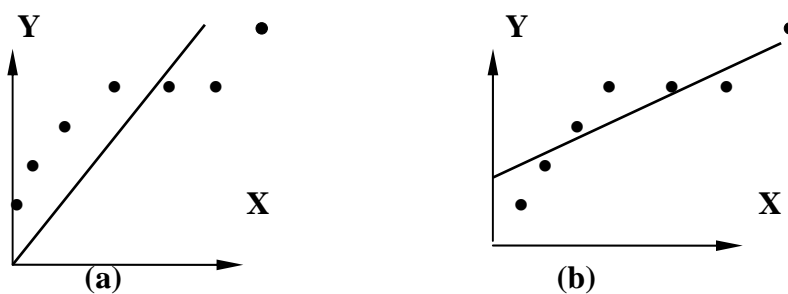

Figure 7.7 Non-linearity

In nonlinear scatter diagram cases, neither the regression nor the correlation analyses are acceptable. It is, therefore, necessary to perform transformations that will cause the scatter diagram to approach linearity. One of the most frequently used such transformation is the logarithmic transformation on one of the variables or on both of them Figure 7.8. It is obvious from Figure 7.8 that by applying the logarithmic transformation on X variable only, how nicely the scatter diagram approaches linearity.

b) **Normality assumption**

For the validity of regression technique it is necessary that variables are normally (Gaussian) distributed. At least the relative frequency diagrams must be either symmetrical or almost symmetrical. If the variables are not cared for the normality it is absolutely necessary that the residuals, $(Y_i - \hat{Y}_i)$, should abide with a normal distribution. Otherwise, the prediction by the regression model is not reliable. The normality of the residual terms implies that the variables are also normally distributed. However, the reverse statement is not correct. The

most widely used transformations on variables for guaranteeing their normality are logarithmic, square root, cube root, etc., transformations.

c) Average of the conditional distribution is equal to zero:

The arithmetic average of residual terms for all given X_i values must be equal to zero. Otherwise, the regression parameter estimations, \mathbf{a}_{YX} and/or \mathbf{b}_{YX} are biased. If the arithmetic average of residual terms is not equal to zero, then the trend in the scatter diagram is not linear.

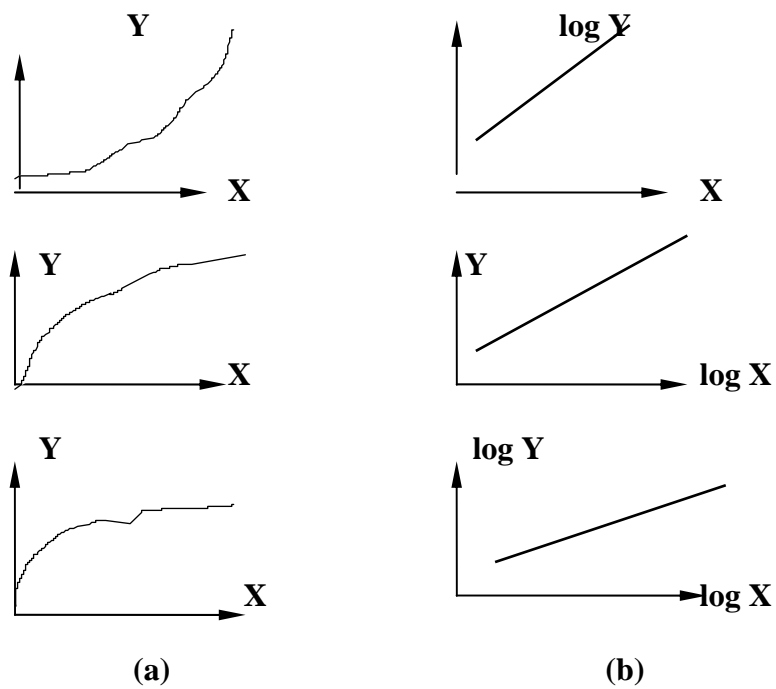

Figure 7.8 Logarithmic transformations

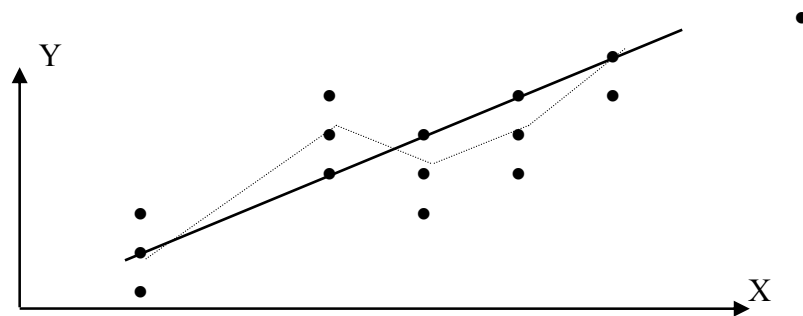

Figure 7.9 Non-normality of the residual terms

In this figure, the average of residual terms, $(Y_i - \hat{Y}_i)$ is not equal to zero for some X values. The tendency between the second and third sets in Figure 7.9 has a steeper line portion.

d) Constant variance (homoscedasticity)

The conditional distribution variance of the residual terms must be constant whatever the independent variable, X, value is. In Figure 7.10 the variance of residual terms for small independent variable values is big and the opposite is valid for big residual terms.

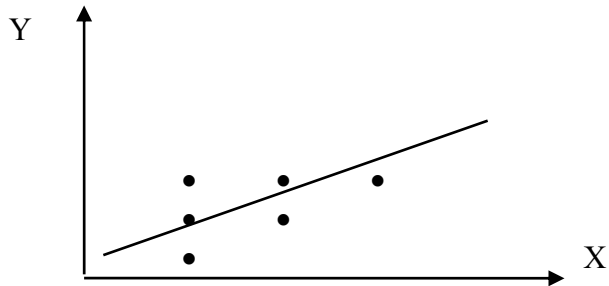

Figure 7.10 Variable variance

In the case of variable variance, all the regression parameters are biased. Fortunately, in practice, different local variances are for small X values. If the variance is equally dependent on X values, then the best transformation to render into a constant variance is by logarithmic transformation.

e) Serial dependence (Autocorrelation)

Each measurement of independent variable is dependent from other measurements. This is tantamount to saying that the measurements of variables (X_i or Y_i) at i-th instant, are independent from the previous instant (X_{i-1} or Y_{i-1}). This implies that the variable at an instant cannot be predicted from the previous instant. This has logical and statistical significance. For instance, the population in 2002 is dependent on the population of 2001 because most of the people live in both years. Hence, these two population values cannot be independent. In other words, population has structural (internal, serial) correlation with time. Similar situation is valid for many natural events. The amount of rainfall at mountain elevations are higher and hence there is a relationship between the rainfall amount and the elevation (see Figure 7.11).

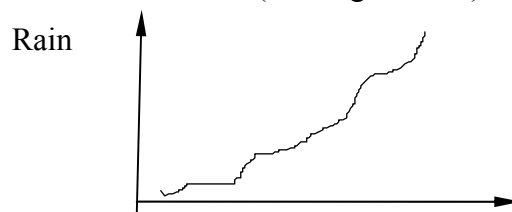

Figure 7.11 Rainfall-elevation relationship

Elevation

Similarly, the rainfall amount increases with distance from the coastal line. Does this increment indicate the constant increment or not? In order to detect this, X and Y variable increments (ΔX and ΔY) at the same time intervals are calculated and plotted against each other on the Cartesian coordinate system as in Figure 7.12.

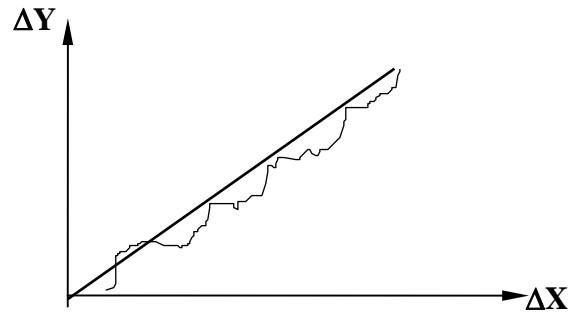

Figure 7.12 Relationship between the increments

f) Measurements are error free

In the search of regression model X and Y variable measurements are considered as error free. Otherwise, the estimation of regression parameters are in biased.

The above regression assumptions are checked to see the reliability of regression model Figures A.1 to A.36. Furthermore, series histograms in Figure 7.13 and other statistical parameters Table A.13 for each variable are also drawn. From the cumulative histograms and statistical parameters, it can be easily viewed that the above assumptions are not valid for this data and this needs a model that is not only assumption free but also gives reliable results. In this situation, a fuzzy modelling is suggested that will be discussed in onward section.

7.2.4 Fuzzy Logic Technique

In the above regression models, all the assumptions are checked to see the reliability of the models. The series histograms in Figure 7.13 and other statistical parameters in Table A.13 are also computed. It can be easily viewed that the above assumptions are not valid for this data and this needs a model that is not only assumption free but also gives a reliable results. In this situation a fuzzy modelling is suggested due to the following reasons.

- 1) Fuzzy logic systems use information efficiently, all available evidences are used, propagated until final defuzzification, robust to uncertain, missing or corrupted data,
- 2) Fuzzy logic systems are cheap, training data are not required, models or joint/conditional probability distributions are not needed,
- 3) Relatively straightforward to design and implement,
- 4) There is nothing fuzzy about fuzzy logic,
- 5) Fuzzy logic is different from probability concepts,
- 6) Designing the fuzzy sets is comparatively easier than any other sort of modeling,
- 7) Fuzzy systems are stable, easily tuned, and can be conventionally validated,
- 8) Fuzzy logic "does not just process control anymore" , and
- 9) Fuzzy logic is a representation and reasoning process.

7.2.4.1 Fuzzy Rules

The fuzzy rules are established depending on the number of subset in each variables on the antecedent side. Out of all possible rules, some logical rules are determined either viewing the histogram charts or triple diagrams as in Figures 7.14 to 7.15 between different variables. These triple diagrams are formatted in SURFER software provided by the Istanbul Technical University, Istanbul. The range of each membership function can adjusted by careful inspection of cumulative histograms Figure 7.13.

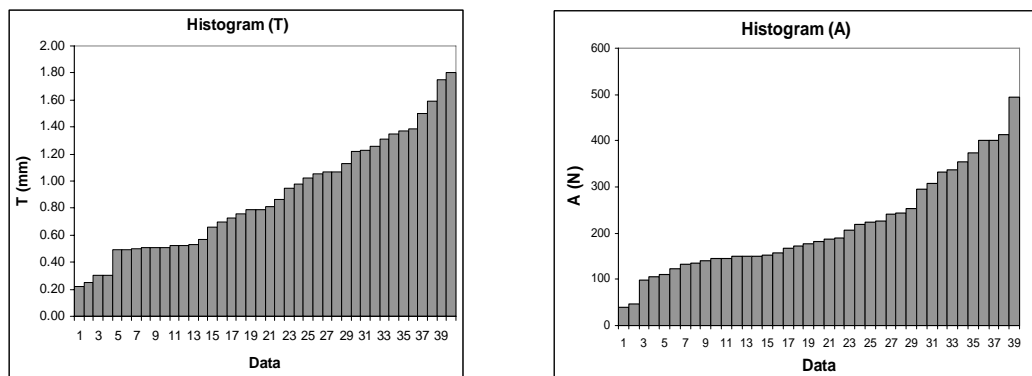
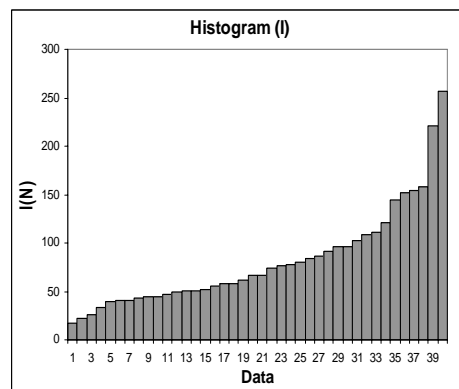
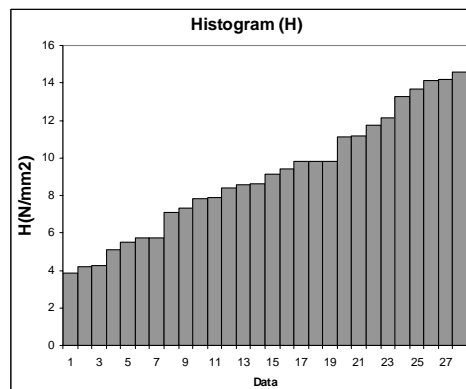
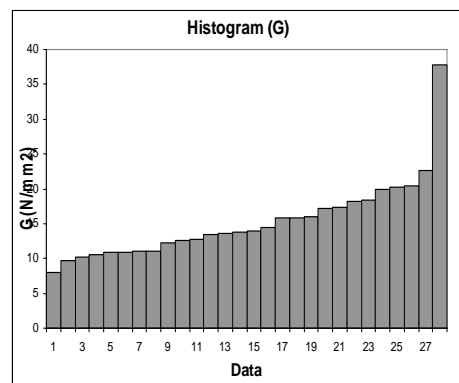
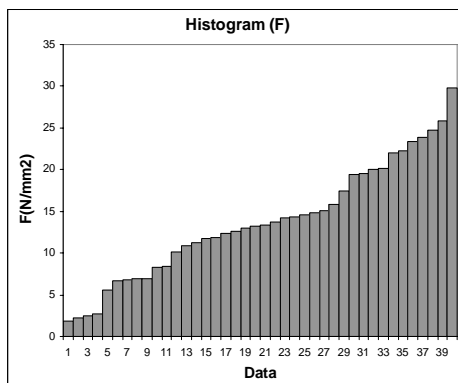
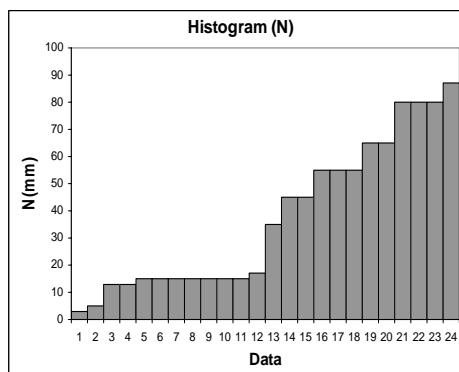
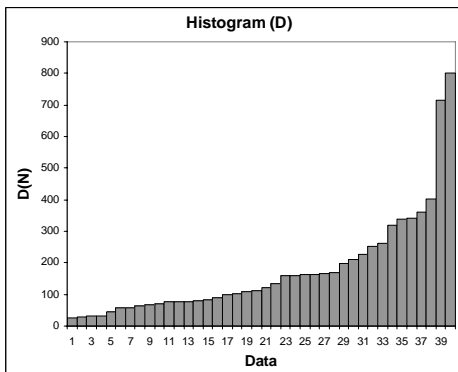
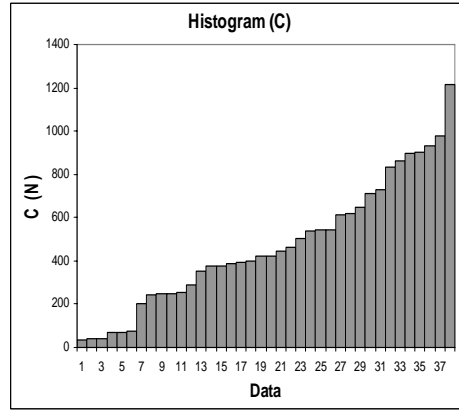
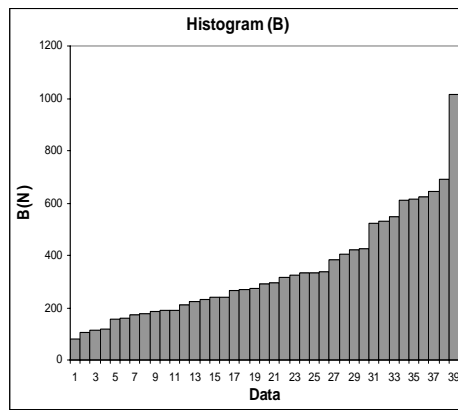

Figure 7.13 Series histograms of different geomembrane testing variables



Continued Figure 7.13 Series histograms of different geomembrane testing variables

7.2.4.2 Triple Diagrams

In visualization of three-dimensional variations at the maximum and the best configuration of such variations can be achieved in three-dimensional Cartesian coordinate systems. However, the best appreciation of three-variable variations can be expressed in the form of contour maps. Such maps, based on three hydrochemistry variables, are referred to as the triple variation diagrams in this paper. In the statistical context, they can be named as graphical regression representation without formal application of restrictive classical statistical approaches such as regression techniques. Triple diagrams help to make interpretations in spite of extremely scatter points. Although Davis (1986) has suggested the application of various simple regional techniques such as inverse distance, inverse distance square, etc. but they consider the scatter points geometrical distances only without the use of a third variable.

On the other hand, the construction of a triple diagram requires three variables two of which are referred to as independent variables and they constitute the basic scatter similar to Figures 7.7 to 7.42. The third is the dependent variable, which has its measured value at each scatter point. The equal value lines are constructed by the Kriging methodology concept (Altunkaynak, 2004). This Kriging methodology is also referred to as geostatistics.

The geostatistical methods take into consideration the effective role of the measured values of a regional variable at a set of irregular sites (or scatter points). The dependent variable in the triple diagram can be considered as regionalized variable and as a random field with data values recorded at scatter points of dependent variable. In general, each random field has its spatial dependence function (SDF) and the spatial continuity is measured by experimental semivariogram. Three dimensions graphs are drawn between different variables in order to see the relationship by keeping different variables as independent. It is obvious from Figures A.42 and A.43 that there are some regions where two variables have high/low concentration with independent variable high/low.

Hence, one can deduce two logical statements concerning these extreme points provided that each variable is vaguely considered by overlapping three linguistic descriptions as "low", "medium", and "high". Consider the case of tensile strength (F), Flexibility/ Stiffness (K) and Thickness (T);

IF F is high and K is high THEN T is high
 IF F is low and K is medium THEN T is medium

Furthermore, other additional logical deductions can also be obtained from a close inspection of the same diagram. For instance, some of them are,

IF F is medium and K is medium THEN T is low,
 IF F is low and K is low THEN T is low etc.

The rules predicted from the triple diagrams can help in deciding the logical rules that are further used in establishing the fuzzy model. The above graphs are prepared according to Kringing procedure through ready software programmes

7.2.4.3 Application of Fuzzy system to Geosynthetics data

In order to develop the fuzzy model for the prediction of critical cone height (N), seam strengths (G and H) and tensile strength (F), the thickness (T) and relative stiffness (RS) constitute the antecedent variables with 6 and 5 fuzzy subsets, respectively. This implies, in general, that there are $6 \times 5 = 30$ rules each attached with one of the convenient 5 fuzzy subsets for variables on the consequent side. Hence, some of these 30 rules will have the same consequent fuzzy subsets. The consequent part of fuzzy subsets of N, F, G, and H are allocated according to expert view by the researcher and some other specialist in the field of geosynthetics. The consensus from expert views are taken as final decision in the establishment of fuzzy rule on the consequent parts under the light of 30 different alternatives in the antecedent part with two variables. Out of 30 rules, 21 rules are selected as logical rules as tabulated in Table 7.2. Hence, prior to actual data usage, the fuzzy system model is obtained as a collection of IF-THEN rules. Such a fuzzy system is very flexible and can digest the imprecise type of information.

In Table 7.3, 1st and 2nd column include the input observed data and 3rd, 4th, 5th and 6th column contain corresponding output observed data. Also 7th, and 8th columns include the combinations of input variables (antecedent part of fuzzy subsets) and 9th, 10th, 11th and 12th column exposes the corresponding fuzzy rule for the consequent part. The IF-THEN rules can be written from this table for each row by locating the fuzzy subsets in 7th and 8th columns with the corresponding fuzzy subset from the 9th, 10th, 11th and 12th columns after THEN part of the rule as consequences.

Table 7.2 Logical rules for fuzzy model TRS-NFGH

T	RS	N	F	G	H
VVH	VS	L	H	H	VH
M	VS	L	H	H	H
VVH	VS	L	H	H	VH
H	VS	L	H	M	VH
VH	VS	L	H	H	M
VVH	S	L	L	H	VL
L	S	L	M	H	VH
H	S	L	M	L	L
M	S	VH	H	H	VH
H	S	L	M	L	L
M	M	M	L	L	M
VH	M	L	H	L	M
L	M	H	M	L	M
H	M	M	H	L	L
H	M	M	H	L	L
H	F	M	M	L	L
L	F	VH	M	L	VL
M	F	VH	M	VL	L
H	F	M	M	L	L
H	VF	VH	M	M	L
VVH	VF	H	L	VL	L

Application of actual data to such a fuzzy system with 30 rules might not trigger some of these rules. Hence, these untriggered rules are not relevant for the prediction of N, F, G and H and should be dismissed from further consideration. If there are significant and regression type of relationships between antecedent and consequent variables, then many of the rules will not be triggered. Otherwise, for very scattered data, almost all the rules will be triggered at different frequencies as in this case 21 rules are triggered. The input observed data, triggered rules and output observed and predicted data are presented in Table 7.3.

Model TRS-FGHN

a) List of input Variables:

- Thickness “T”
- Relative Stiffness “RS”

b) List of output Variables

- Critical Cone Height “N”
- Tensile Strength “F”
- Seamed Shear Strength “G”

c) **Membership Functions (MFs)**

For each variable, MFs are selected in order to grasp the data. The MFs have their values on the horizontal axis. The variability domain of the variable concerned with the membership degree is on the vertical axis. In a way, MFs are the transformers of data values to MDs or given MDs degrees to data value. Such a transformation is referred to as the triggering or firing feature of the fuzzy rules.

Input membership functions

1. Thickness (T)

VL	Very low
L	Low
M	Medium
H	High
VH	Very
VVH	Very very high

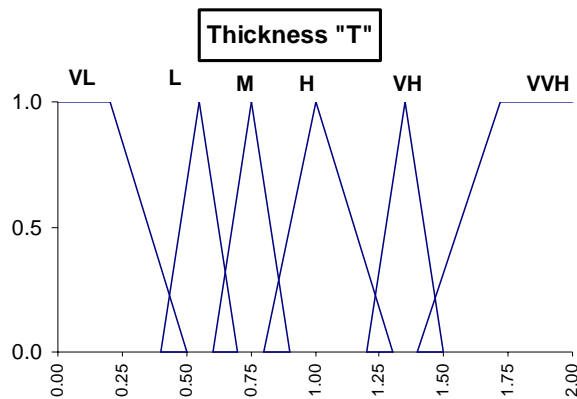

2. Relative Stiffness (RS)

VS	Very stiff
S	Stiff
M	Medium
F	Flexible
VF	Very flexibl

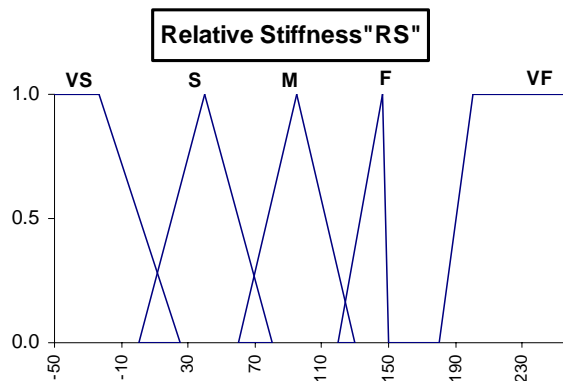
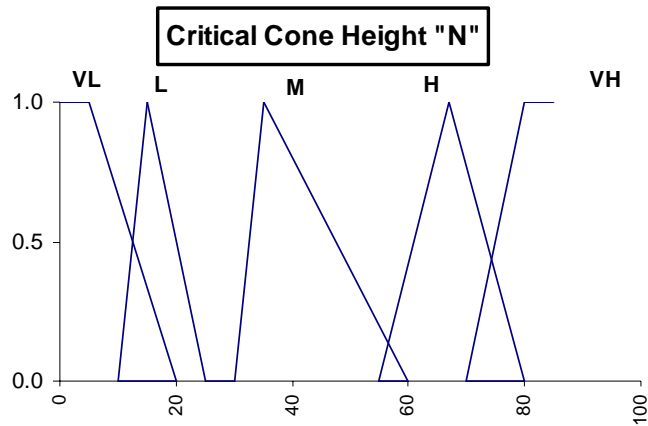

Figure 7.14 Input Fuzzy MFs for Fuzzy Model TRS-NFGH

Output membership functions

1 Critical Cone Height (N)

- VL Very low
- L Low
- M Medium
- H High
- VH Very high



2. Tensile Strength (F)

- VL Very low
- L Low
- M Medium
- H High
- VH Very high

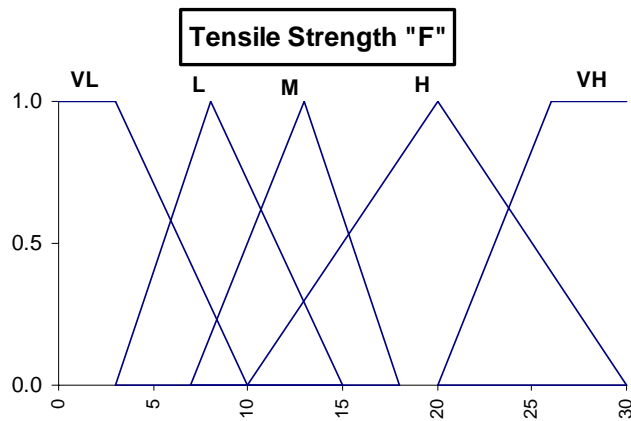

3. Seamed Shear Strength (G)

- VL Very low
- L Low
- M Medium
- H High
- VH Very high

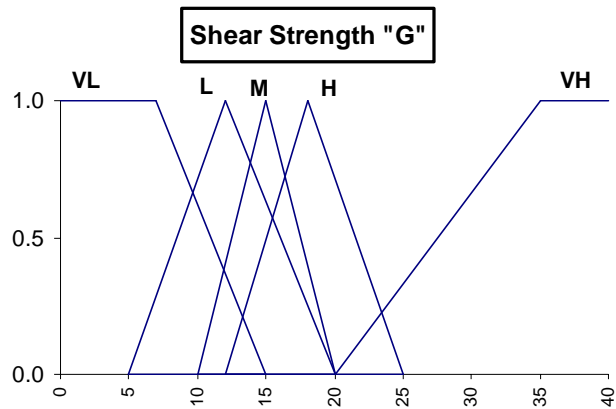

4. Seamed Peel Strength (H)

- VL Very low
- L Low
- M Medium
- H High
- VH Very high

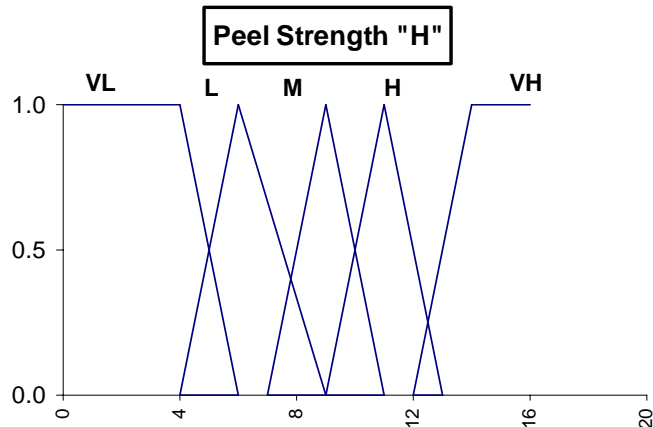

Figure 7.15 Output fuzzy membership functions for Fuzzy Model TRS-NFGH

d) Fuzzy Results

Fuzzy modelling is run using the MATLAB programme provided by the computer department of Istanbul Technical University Istanbul and results are presented in tabular forms as in Table 7.6. The accuracy of the results depends upon the % error between observed and predicted values. About 10 trials are conducted by changing the ranges of the MFs and ultimately the following results are obtained with % age of error between 10 to 15%. The accuracy of data is presented in graphical form between observed and predicted values (see Figure 7.18).

Table 7.3 Fuzzy results showing observed input data, fuzzy triggered rules and observed & predicted output data for model TRS-NFGH

Inputs/Data						Rules						Results								
T	RS	N	F	G	H	T	Rs	N	F	G	H	N	F	G	H	Rn	Rf	Rg	Rh	
1.59	252	13	22	23	15	VVH	VS	L	H	H	VH	17	20	18	14	23	10	19	2	
0.79	230	15	23	20	11	M	VS	L	H	H	H	17	20	18	11	10	14	9	1	
1.75	228	15	26	18	13	VVH	VS	L	H	H	VH	17	20	18	14	10	23	0	8	
1.13	209	15	25	16	14	H	VS	L	H	M	VH	17	20	15	14	11	19	6	1	
1.31	198	15	19	18	9	VH	VS	L	H	H	M	17	20	18	9	10	3	0	5	
1.50	146	15	8	17	4	VVH	S	L	L	H	VL	17	9	18	3	13	4	6	34	
0.51	142	13	15	20	14	L	S	L	M	H	VH	17	13	18	14	22	16	10	2	
0.86	138	17	14	12	8	H	S	L	M	L	L	49	18	15	10	20	22	18	20	
0.76	125	80	24	20	14	M	S	VH	H	H	VH	58	17	16	12	27	29	22	12	
0.98	121	15	14	13	7	H	S	L	M	L	L	42	20	12	6	15	28	8	12	
0.79	108	35	11	14	9	M	M	M	L	L	M	42	9	12	9	17	19	10	1	
1.26	93	15	20	13	10	VH	M	L	H	L	M	29	20	12	8	20	1	2	17	
0.49	90	65	15	14	10	L	M	H	M	L	M	67	13	12	9	4	14	11	8	
1.07	89	45	22	11	7	H	M	M	H	L	L	42	20	12	6	7	9	12	11	
0.95	89	55	20	11	8	H	M	M	H	L	L	42	20	12	6	23	0	11	20	
1.02	58	55	14	10	8	H	F	M	M	L	L	43	13	12	6	23	8	18	19	
0.52	52	80	13	14	4	L	F	VH	M	L	VL	79	13	12	3	1	3	11	32	
0.70	45	87	13	8	6	M	F	VH	M	VL	L	79	13	6	6	9	5	23	10	
1.05	44	55	17	11	6	H	F	M	M	L	L	42	13	12	6	24	27	10	10	
0.81	-23	80	16	16	8	H	VF	VH	M	M	L	78	12	15	7	3	21	5	18	
1.80	-34	65	11	10	5	VVH	VF	H	L	VL	L	67	9	6	6	3	23	42	19	
							Avergae error (%)										14	14	12	13

T Thickness *RS* Relative Stiffness
N Critical Cone Height *F* Tensile Strength
G Seamed shear strength *H* Seamed peeling strength
R_n, R_f, R_g, R_h Relative error(%) between observed and predicted values of *N, F, G,*
and H respectively.

7.2.4.5 Reliability of Fuzzy Model

In order to check the reliability of the model developed herein by using FESS project observed data, an independent of observed data of *N, F, G,* and *H* are also obtained from the project. It is obvious that the measured and predicted output variable values are very close to each other with less than 15%, 11% and 9.5% after about 10 trials. This shows the validity of fuzzy rule set for tensile and seamed strength prediction provided that there are thickness and relative stiffness data data is available for geosynthetics materials.

Finally, Figure 7.18 shows observed verses predicted seepage fall around the 45° straight line with acceptably small variations. Since, the overall deviations from the

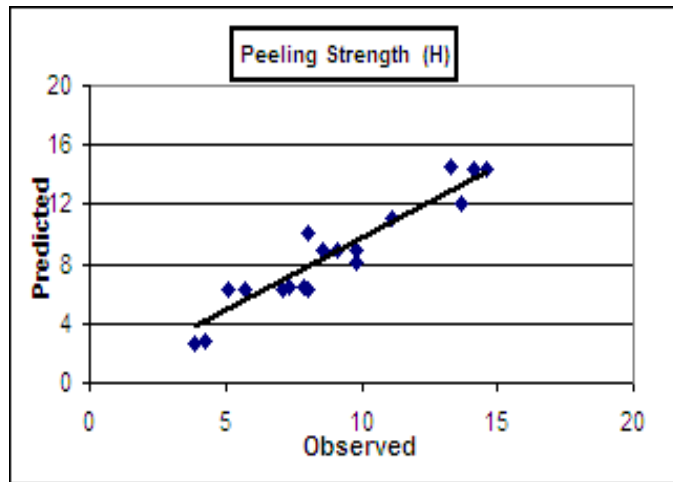

Continued figure 7.16 Graph between observed and predicted values

8. CONCLUSIONS AND RECOMMENDATIONS

8.1 Seepage Investigations

8.1.1 Comparison of seepage methods

The detailed diagnosis and evaluation of the relative merits and demerits and to intrinsic measurement inaccuracies involved in the two seepage measurement techniques, i.e., ponding and inflow-outflow (I-O) methods indicate ponding test as more reliable and accurate in determining seepage rates from irrigation canals. This is further verified through review of the statistical analysis of FESS canals's determinations. In brief, the mean standard deviations for ponding test replications vary between 2 to 6 mm/day (0.07 to 0.22 cfs/msf) with coefficient of variation from about 3 to 8 % and absolute mean standard errors lie within 0.25 to 1.3 mm/day (0.01 to 0.05 cfs/msf) for the ponding tests. Analysis of the (I-O) test replications on these channels reveal exceedingly higher magnitudes for the observed standard deviations of 11 to 42 mm/day (0.42 to 1.6 cfs/msf) with the resulting coefficients of variation ranging between 9 to 42 % and mean standard error values varying between 5 to 17 mm/day (0.2 to 0.65 cfs/msf). This leads to conclude that the ponding seepage rates can safely be adopted to quantify seepage losses for unlined channel in the FESS project.

Upon applying these predicted amount of seepage reduction through the ongoing FESS lining under the project's phase-I, the estimates in the Table 6.6 indicate total water saving of 1,855 hectare-m (15,215 acre-ft) annually with corresponding net additional water availability at root zone as about 1,390 hectare-m (11,400 acre-ft) per year from FESS canal lining. Comparing these water savings from lining to the estimated incremental surface water availability of 69,360 hectare-m (91,000 acre-ft) annually (World Bank, 1992) through the cumulative water conservation measures under the project. (I.e. interceptor drains, canal lining and water management practices), the projected benefits from FESS phase -I appear grossly overestimated.

8.1.2 Construction Aspects

1. Geomembrane covered with any type of hard cover of 50 – 76 mm (2 -3 inches) with proper joint sealing have shown high degree of seepage loss reduction (above 90%). These sections include 2c, 5a, 5c, 5cd , 5n, 6, 8, and 9 types of lining,
2. The effect of geotextile was not visible as both the sections with and without geotextile have shown 80-90% loss reduction as in case of 3a and 3b,
3. Joint sealant is important as in types 2c with joint sealant showed high degree of seepage reduction as compared to 2a without joint sealant with poor results, i.e. seepage loss reduction below 60%,
4. Option 2 geomembrane with soil cover on bed and sides is fairly good, i.e. 70-80 seepage loss reduction, if section properly maintained and soil cover on banks remains intact,
5. The lining options -1 geomembrane on bed only gave poor results, below 60% seepage loss reduction. This indicates the need for lining of the slopes, and
6. The research concludes that lining have significantly positive effect on hydraulic performance of lined channels, water supply conditions at the tail end has improved in term of reliability.

8.1.3 Analysis techniques

Different analysis techniques are tried in order to get the relation between seepage parameters. For this purpose, scatter diagrams are drawn between the variables and tried to correlate them by regression technique. No significant relation can be found, due to the regression model assumptions. Also it is clear from the data that none of the variable meets the required assumptions for the model.

In order to cater this problem fuzzy logic modelling technique is employed as it is assumption free and gave reliable results within certain limits. Two fuzzy models have been developed named LAQ-Sp and LAQ-Si for seepage investigation by ponding and I-O methods, respectively. These two models gave results within 10% error. So just by measuring some variables, the results can be easily predicted by these models.

In order to check the reliability of the developed models, an independent seepage observed data is also obtained from the project. It is obvious that the measured and predicted seepage are very close to each other with 15%, 11% and 9.5% for three trials, respectively. This shows the validity of fuzzy rule set for seepage prediction provided that there are length, wetted area and discharge data from the canals. Finally, Figures 6.21 and 6.24 show observed versus predicted seepage fall around the 45° straight line with acceptably small variations. Since, the overall deviations from the straight line for both models are less than 10% the fuzzy models LAQ-Sp and LAQ-Si as presented in this thesis are acceptable for seepage prediction from canals.

8.1.4 Recommendations Regarding Seepage Evaluation

- 1 Seepage losses from the channels are much less than estimated at the project's appraisal stage. This hints towards the need for considering a reliable trade off between huge investment on lining and expected water savings, therefore only selective lining of the channel section having high seepage rates may be carried out,
- 2 The research is also needed to establish the long term seepage control effectiveness of different types of lining due to sealing of joints with silt deposits,
- 3 Long term monitoring of the post lining hydraulic performance and sediments phenomenon is also needed to be carried out,
- 4 Keeping in view local field conditions, effort should be made to use locally available geomembrane for lining purpose, and
- 5 Two fuzzy models have been developed so far by using three variables as input. These models can be extended and made more versatile by adding more variables like soil characteristics, groundwater levels, climate and also others local effects.

8.2 Geosynthetics

The research presented the results of the work in the geosynthetics laboratory. Many lining types were tried out under field conditions, including both conventional and

innovative ones (Bodla et al, 1998). The canal system of the FESS area normally carries water for eleven months of the year, so special attention was paid to possible ways of the lining canals quickly enough to avoid the need for temporary diversion channels, which though not very costly in financial terms are disruptive and difficult to arrange.

The laboratory work reported has provided valuable insight and information into various test methods available for evaluating and comparing different geomembranes, and also into the properties of about fifty such materials. The analysis can help with the preparation of designs and specifications for any future lining projects that use such geosynthetics. It is especially relevant to the use of material neutral, performance type specifications, which are often preferable to the more traditional type which prejudices the chemical nature of the materials. A material-neutral specification leaves manufacturers free to pass on to their clients the advantages of recent development in the geosynthetics technology. The use of such specifications is recommended for any future canal lining project using geosynthetics.

8.2.1 Laboratory Results

Following conclusions can be drawn from the laboratory tests of various geosynthetics materials.

- 1 Although thickness of the material is not indicative of the field performance but its value is required in calculation of some of the geomembrane parameters such as puncture resistance, tensile stress etc. Linear relationship is observed to hold between the maximum stress and thickness,
- 2 The polypropylene materials are more flexible as compared to polyethylene materials as indicated by the stiffness test,
- 3 Highly dense and very low density polyethylene materials show good response against slow puncture resistance tests (index tests). Pyramid over water gives comparatively higher values of puncture resistance ranging from 250 N to 900 N as compared to other slow puncture tests,
- 4 Flexible polypropylene alloy (FPA) and other flexible) materials puncture at high critical cone height as compared to polyethylene materials (HDPE and textured geomembrane,

- 5 Testing of mechanical behaviour of geomembranes particularly their behaviour under tensile testing is of extreme importance for designing of a water proofing system. Dumbbell shape specimen is preferred to the strip in tensile strength test but flow of material from grips can affect the results, and
- 6 Geomembrane seams are tested for continuity and mechanical strength. Destructive testing of seams provides direct evaluation of seam strength and bonding efficiency, which indicates seam durability.

There are certain tests which are found promising as indicators of performance of geosynthetic materials through the laboratory testing. These tests can help in drawing up the material neutral specifications. Comparative tests on 32 unreinforced geomembranes showed quite strong correlation between each of these tests and the usual dumbbell tensile test. The pyramid over water test, however, showed less correlation, either with tensile test or with the other two puncture tests. The critical cone height from hydrostatic test showed almost no any correlation with any other parameter, even thickness, confirming its status as a measure of distinct property. The only parameter found to be related to critical cone height was a hybrid one called relative stiffness (RS). It is an empirically derived parameter indicating stiffness relative to thickness, defined as “L-150t”, where L is the overhang length in stiffness test and “t” is the geomembrane thickness. Geomembrane tested were provisionally grouped into five classes, as shown in the Table 8.1.

Table 8.1 Classification of materials with respect to stiffness

No.	Parameter	Relative Stiffness (RS)	Materials
1	Very stiff	More than 180 mm	HDPE
2	Stiff	120 – 180 mm	Most LDPE
3	Intermediate	60 – 120 mm	VLDPE, VFPE; Some LDPEs
4	Flexible	0 – 60 mm	FPA
5	Very flexible	Less than 0	Rubber and other materials

8.2.2 Basic test for analysis of geomembrane

In order to define the most important properties of a geomembrane material the following basic set of tests would be needed with the following order.

1. Thickness test,
2. Stiffness test,

3. Hydrostatic cone test giving critical cone height with minimum critical cone height 20 to 60 mm depending on how important resistance to puncturing by sharp objects is considered to be,
4. Pyramid over water puncture test which determines the acceptable thickness with minimum puncture force 200 to 600 N. Simulating a sharp puncturing object resisted without sub-grade support,
5. Pyramid over aluminium puncture test simulating the geomembrane against a hard sub-grade with a required puncturing force of 70 to 150 N, and
6. Tensile strength test and corresponding seam tests i.e. shear test and peel test.

These laboratory investigations show that there is scope for reducing the cost of using geomembranes in canal linings by careful refinement specifications. Under suitable conditions, it should be possible to use geomembrane manufactured, or at least extruded, in countries like Pakistan, which can help to reduce the cost.

8.2.3 Analysis techniques

Different scatter diagrams are drawn between different variables in order to get the most suitable relation between the variables so that by conducting a few physical tests, the related mechanical properties can be determined for certain project without going for a long series of tests. From the scatter diagrams, it is clear that no significant relation can be developed by regression modelling technique due to the reason that most of the variables are not satisfying the regression model assumptions. Under this situation, fuzzy model TRS-NFGH has been developed using thickness and relative stiffness as input variables. These two variables can be measured by physical mean without involvement of any mechanical equipment. So just by putting these two physical measurements in the model, the other mechanical properties can be determined.

In order to check the reliability of the model developed, an independent observed data for critical cone height; N , tensile strength; F , seam shear strength and seam peel strength; H are also obtained from the project. It is obvious that the measured and predicted data for these variables are very close to each other. This shows the validity of fuzzy rule set for prediction of N , F , G and H properties provided that the thickness and relative stiffness data are available from the seepage control materials for the canals.

Finally, Figure 7.18 shows that observed versus predicted values fall around the 45° straight line with acceptably small variations. Since, the overall deviations from the straight line for both models are less than 14% the fuzzy models TRS-NFGH as presented in this thesis is acceptable.

8.2.4 Recommendations

The Following recommendations can be made based on the laboratory testing of various geosynthetics materials

- 1 Polyethylene's (HDPE and VLDPE) are recommended as suitable geomembrane for canal lining similar to those existing in FESS project,
- 2 A minimum of 0.50 mm and a maximum of 0.75 mm are recommended thickness for lining of water conveyance canals,
- 3 The materials should be sufficiently flexible to retain any shape of the canal when placed into canal,
- 4 The puncture resistance force should be 490 N in pyramid puncture test over water,
- 5 The geomembrane should not be punctured in a large scale hydrostatic cone test with a cone height of 40 mm. The pressure should rise to 100 psi over a period of one to two hours and keep that pressure for a further 48 hours,
- 6 The sub-grade should be compacted before laying of the geomembrane so that it may minimize the factor of puncture related to cone height as in the case of hydrostatic puncture test, and
- 7 One model has been developed so far by using two variables as inputs. This model can be extended and made more versatile by adding more variables like soil characteristics, biological effects and also age factor.

9. REFERENCES

- Ahmad, N.**, 1974. Groundwater Resources of Pakistan, Institute for Engineers, 61-B/2 Gulberg-III, Lahore, Pakistan.
- Ahmed, N.** 1982. An Estimate of Water Loss by Evaporation in Pakistan, Irrigation, Drainage and Flood Control Research Council, Lahore, Pakistan, p-71.
- Ahuja P.R. and Mehndiratta**, 1967. Canal lining - A Review. Central Board of Irrigation and Power, *Symposium on Canal Lining*, New Dehli, India, July 19-23, 173-180.
- Altunkaynak, A., Özger, M., and Şen, Z.**, 2004. Triple diagram model of level fluctuation in Lake Van , Turkey. *Journal of Hydrology and Earth Sciences*, **2**, 235-244.
- Asmus, D.B.**, 1979. Geomembrane Sealing of a Waste Disposal Area, *Geosynthetic Case Histories*. ISSMFE committee TC9.
- ASTM**, 1995. Standards on Geosynthetics, 4th Edition, ASTM 100 Barr Harbor Drive WEST Conshohocken, PA 19428-2959.
- Bell, J. R. and Yoder, E J.**, 1957. Plastic moisture barrier for highway Subgrade protection. *Highway Research Board*. Washington D.C., **36**, pp 713-735.
- Bouwer, H.**, 1965. Theoretical aspects of the seepage from open channels. *Journal of Hydraulics Division, ASCE*, **91(3)**, No. HY3, 37-59.
- Bauwer, H.**, 1969. Theory of Seepage from Open Channels, in advances Hydroscience, Ven Te Chow, Ed., Academic Press, New York, **5**, 121-172.
- Bhutta M.N.**, 1990. Effect of varying discharge on equity of water distribution in the irrigation system. *Ph.D. Dissertation*, CEWRE, University of Engineering and Technology Lahore, Pakistan
- Bhutta M.N., Vlotman W.F., Khan M.A., and Roos P.**, 1992. Seepage losses from irrigation canals of Punjab in Pakistan, *International Conference on Advances in Irrigation*, Leuven, Belgium.

- Bodla, M. Abid, A. Hafeez, M. Tariq, M.R Chohan and M. Alam**, 1998. Seepage equity and economic evaluation for irrigation canal lining in FESS project, *IWASRI Publication* **204**, 11-18 and 52-54.
- Brush, J.C. and Street, R.L.**, 1967. Seepage from an array of triangular channels. *Journal of Engr. Mech. Div., ASCE*, **91**, No.EM3, 63.
- Carter R.W.**, 1970. Accuracy of current meter measurement, *International Symposium of Hydrometry*, Kolblenz, Germany, UNESCO., September 13-19, 223-233.
- Christopher, J. N.**, 1981. Comments on canal seepage measuring and estimating procedures. *World Bank Seminar*, Washington, USA., April 10-12, 129-135.
- Christopher, B. R.**, 1982. Geotextile filtration principles, practices and problems. *Journal of Geotextiles and Geomembranes*. **11**, 250-259.
- Cheheena M. A. And Piracha Z. A.**, 1993. Monitoring Irrigation Water Flows in a Sub-System. *Irrigation System Management Research*, Booklet 1B, Bhalwal, ISMR, 33.
- Charles H.W.**, 1963. Seepage problems in West Pakistan. *Proceeding of Seepage Symposium*, Phoenix, Arizona, September 12-15, 234-239.
- Chohan, M. A.**, 1989. Canal irrigation in Pakistan, *Proceedings of International Conference on Irrigation Theory and Practice*, University of Southampton 12-15 September, 105-114.
- Dachler, R.**, 1936. *Grundwasserströmung*. Springer, Wein.
- De Ridder N.A.**, 1980. Groundwater survey, *Surveys and Investigations, Drainage Principles and Applications*, **3 (16)**, 153-194.
- Deacon, N.H.G.**, 1984. Seepage and Durability of Irrigation Canal Lining. *Technical Note OD/TN5, Hydraulic Research*, Wallingford, UK.
- FAO**, 1977. Canal lining, Irrigation and drainage, **2**, *Land and Water Division, Food and Agriculture organization*, Rome.
- Fayoux D.**, 1984. Behaviours of geomembranes in relation to the soil. *Proceeding, International Conference on Geomembranes*, Denver IFAI., Colorado, June, **2**, 421-426.
- Frobel, R. K.**, 1981. Design and development of an automatic hydrostatic flexible membrane test facility. *U S Bureau of Reclamation Report*, Colorado, January, **REC-ERC-80-9**.
- Giroud, J. P.**, 1985. Geotextiles in Geotechnical Engineering. *Geotextile and Geomembranes Manual*, UK.

- Goldsmith, H. And Makin, I.W.** 1989. Canal Lining, from laboratory to field back again, *Proceedings of International Conference on Irrigation Theory and Practice*, University of Southampton, UK, 12-15 September, 356-365.
- Grover R.E.,** 1974. Transient ground water hydraulics, *Fort Collins Report, C235*, Colorado State University, Colorado, USA.
- Haider and J. Maclung,** 1989. A review of key performance indicators CWM Project, *Command Water Management*, Punjab, Pakistan.
- Harr, M.E.** 1962. Groundwater and Seepage, McGraw-Hill Book Company, 231-248.
- Hassan, GZ, Javed, I., Bhutta, M. N and Boers, T.M.,** 1995. Rainfall Analysis at Bahawalnagar for FESS project, Lahore- Pakistan
- Haxo, H. E.** 1986. Quality assurance of geomembranes used as linings for hazardous waste containment, *Journal of Geotextiles and Geomembrane* ,4, 148-152.
- Holmes, D.W., Wooldridge, R. Weller, J.A., Gunston, H. And Batchelor, C.H.,** 1981. Water management study at Kadulla irrigation scheme, Sri Lanka, **OD 38**, HRS Wallingford, England.
- Holliday, T. M.** 1982. What you need to know to get into Geotextiles, *Journal of Textile World*, **2**, Horizons.
- Hotes, F.L., Kruse, E.G., Cristopher, J.N., Naiz, S. Robinson, A.R.,** 1985. Irrigation canal seepage and its measurements, a state of art review, Irrigation and Drainage system, San Antonio, Texas, USA, *Amercian Society Civil Engineering*, 93-105.
- Ingold, T. S.** 1994. Geotextile and Geomembranes Manual, 1st Edition. Elsevier Advance Technology Oxford OX2 7DH, England.
- Irshad, A.,** 1989. Effects of animal trespassing on geomembranes. *Engineering News*, Pakistan Engineering Council, Islamabad, Pakistan.
- Irshad, A.,** 1991. Damaging effect of weeds on geomembrane lining, UNDA Report. UNIDO, Lahore Pakistan.
- John C.J and Remco E.S.,** 1990. Hydraulic performance of Fordwah Branch during Rabi season, *Research on Improvement of Canal Performance*, IIMI, Pakistan.
- Kennedy R.G.,** 1895. Prevention of silting in irrigation system, *Proceeding of ICE*, **11g**, Part I, 280-290.

- Koerner, R. M.**, 1994. Designing with Geosynthetics, 3rd Edition Prentice Hall Englewood Cliffs, New Jersey, USA.
- Kolupaila S.**, 1964. Discussion on accuracy of current meter measurements, *Journal of Hydraulics Division*, ASCE, **90**, HY1, 352-355.
- Koop, J.**, 1991. Geomembrane sealing for an irrigation canal, *Geosynthetics Case Histories*, ISSMFE Technical Committee, **TC9**, UK.
- Kozany, J.**, 1931. Grundwasserbewegung bei freiem Spiegel, *Fluss and Kanalversickerung*, Wasserkraft und Wasserwirtschaft, **3**, 26.
- Kraatz, D.B.**, 1977. Irrigation Canal Lining, Food and Agriculture Organization of the United Nations, Rome, Jan., ISBN 925101650, p-199.
- Lacroix Y.**, 1984. Construction of geomembranes liner at Terzaghi Dam, *Proceeding International Conference on Geomembranes*, Denver Colorado, Industrial Fabrics Association, **December 22-25, 211-214**.
- Laine, D.L.**, 1989. Loading point puncturability analysis of geosynthetic linear materials, *Proceeding Geosynthetics*, **89**, San Diego, IFAI Publishers.
- Lauritzen, C. W. and Peterson, W. H.**, 1953. Butyl fabrics as canal lining materials, *Utah Agriculture Experimentation*, USA., Bulletin **363**, p-16
- Montez, F. T. and Maroni, L. G.**, 1990. Use of geotextiles and geomembranes in irrigation channels - Brazilian Case Histories, *Proceeding, 4th IGS Conference*, The Hague, The Netherlands, **2**, 449-452.
- Morel Seytoux, H.J.**, 1964. Domain variations in channel seepage flow, *Journal of Hydraulics Division*, ASCE, **90**, (HY2), 220-229.
- Morrison, W.R.**, 1990. Use of geosynthetics for the under water lining of operating canals, *4th International Conference on Geotextiles, Geomembrane and Related products*, The Hague, **2**, 443-448.
- Mott Macdonald**, 1995. Design report FESS project, *Canal Lining Component*, Bahawalnagar, Pakistan.
- Mumdani, E. H.**, 1974. Application of fuzzy logic to approximate reasoning using linguistic synthesis. *IEEE Transactions and Computers*, **C-26**, 1182-1191.
- Murthy L.K.**, 1980. Experience of operation and maintain of some of our irrigation canal system, *Proceeding of the Symposium on Operation and Maintain of Canal System*, New Dehli, India, May, 129-134.
- NESPAK**, 1991. Additional studies appraisal report, *Fordwah Eastern Sadiqia Project*, Bahawalnagar, Pakistan.

- OCCS**, 1986. Research, studies and ponding tests, *Summary Report*, Project Manager, Nebraska- Kansas, USA.
- O'Mara, G.**, 1986. Conjunctive water use, *Proceedings of the Budapest Symposium*, IAHS, Hungary, **156**, July, 235-239.
- Paul, T.C. and Dhillon, G.S.**, 1989. Modernization of Punjab irrigation system, ASIM, *Regional Symposium on Modernization and Rehabilitation of Irrigation and Drainage Schemes*, Hydraulic Research Station, Wallingford, England, **May 20**, 119-123.
- Patten E. P., Hussain A. And Ali S.**, 1963. Analysis of seepage studies on unlined canals in the Punjab, *Technical report*, **4**, West Pakistan.
- Pontin, J.M.A., Laila Abed and Weller, J.A.**, 1979. Prediction of Seepage Loss from the enlarged Ismaili Canal, *Report*, **OD 28**, HRS, Wallingford, England.
- Purdy, A. T.**, 1983. Development in Non-Woven Fabrics, *Textile Progress*, **12**, 4th Edition, The Textile Institute, Colorado.
- Purushottam J.**, 1980. Design , operation and maintenance of irrigation canals, *Technical Report*, Andhra Pradesh.
- Rajan, B.H.**, 1980. Some thoughts of maintenance of the canals, *Proceeding of the Symposium on Operation and Maintenance of Canal System*, New Dehli, India, May, 110-114.
- Rawlings, B.**, 1984. Geomembrane for reservoir water proofing Muna Reservoir Project, *Geosynthetic Case Histories*, ISSMFE Committee, **T09**.
- Rigo, J. M.**, 1977. Correlation of puncture resistance over ballast and the mechanical properties of impermeable membranes, **2**, RILEM, 188-193.
- Robison A.R.**, 1981. Methods of measuring losses in irrigation channels, *Civil Engg. Manual*, London.
- Renold K. Frobel and C. Brent Cluff**, 1976. Plastic reinforced asphalt seepage barrier, *Journal of the Irrigation and Drainage Division*, **4**, 369-379.
- Schmidt, C.** 1985. Geosynthetics sealing of waste disposal area, *Geosynthetics Case Histories*, ISSMFE Technical Committee, **TC9**, UK.
- Singh, Dr. T.**, 1987. Seepage and total system losses on lined and unlined water courses of Punjab State Corporation, *Irrigation and Power Research Institute Technical Report*, Amristar, Punjab, **Phy/31**, 87.
- SIA., 280**, 1975. Test Methods on Materials, Water Proofing Membranes in Plastic Materials, Switzerland.

- Snell, M.J.**, 1996. Experimental canal lining advisory consultancy, *IWASRI Internal Report, 1g*, Lahore, Pakistan.
- Snell, M.J.**, 1999. Canal lining advisory report, *FESS Canal Lining Project*, Lahore, Pakistan.
- Staff, C. E.**, 1984. The foundation and growth of the geomembrane industry in the United States, *Proceeding International Conference on Geomembranes*, IFAI Denver, June 22-23, 204-207.
- Steiniger, F.**, 1968. The Effect of Burrower Attack on Dike Liners, *Wasser and Boden*, Berlin.
- Shahid B.A.**, 1988. Low cost lining of irrigation canals, *Report Submitted to the Department of Civil Engineering*, University of Idaho, USA.
- Siddiqui, M. Pasha, F.H and Choudri, A.M.**, 1993. Seepage loss measurement on chashma right bank canal, *Proceeding Workshop on Canal Lining and Seepage*, Lahore, Pakistan, 18-21 October, 1993.
- Şen, Z.**, 1995. Applied Hydrology for Engineers and Scientists, CRC Lewis Publishers, Boca Raton, USA, 465.
- Şen, Z., and Altunkaynak, A.** 2004. Fuzzy awakening in rainfall-runoff modelling, *A journal of Nord. Hydrol*, **35**, 31-43.
- Şen, Z.**, 2004. Fuzzy Logic and System Models in Water Science, Istanbul, Turkey, 155-175.
- Şen, Z.**, 2003. Data Analysis Techniques, *1st International Advance Course on Water Resources organized by WERDEC under the umbrella of Water Foundatio*, Istanbul, Turkey, August 11-20, 65-115.
- Shahid B.A.**, 1988. Low costing lining of irrigation canals, *Report submitted to the Department of Civil Engineering*, University of Idaho, USA.
- Smith, R.J. and A.K. Turner**, 1982. Measurements of seepage from earthen irrigation channels, *Civil Engineering Transactions*, Insitittute of Engineers, Australia, 338-345.
- USBR.**, 1954. Lining for Irrigation Canals, *US Bureau of Reclamation*, Philadelphia USA.
- USBR.**, 1960. Earth Manual, *US Bureau of Reclamation*, 1st Edition 751.
- US**, 1989. Design memorandum subsurface drainage 4th Drainage Project (LRRP), Faisalabad, Pakistan. *Report by US Department of the interior, Bureau of Reclamation*, denver, Colorado, USA.

- Vedernikov, V.V.**, 1934. Versickerungen aus Kanalen, *Wasserkraft und Wasserwirtschaft Report*, **C15**, 11-13 and 82.
- Wachyan, E. and Ruston K. R.**, 1987. Water losses from irrigation channel, *Journal of Hydrology*, **75**, 275-288.
- WAPDA**, 1965. Lower Indus Project, *Hunting Technical Services, Report*, **1**, Pakistan.
- WASID**, 1963. Analysis of seepage losses from unlined canals in the Punjab. *Water and Soil Investigations of WAPDA, Technical Report*, **4**, Lahore, Pakistan.
- Weller, J.A. and McAter, P.**, 1993. Seepage measurement techniques and accuracy, *Proceedings Workshop on Canal Lining and Seepage*, Lahore, Pakistan, 8-21 October, 1993, 111-115.
- Weller, J.A.**, 1981. Estimation of errors in canal seepage, *Hydraulics Research Report*, **OD 25**, Wallingford, UK.
- World Bank**, 1992. Fordwah Eastern Sadiqia (South) Irrigation and Drainage Project, *Staff Appraisal Report*, Bahawalnagar, Pakistan..
- Worstell, R.V.**, 1976. Estimating seepage losses from canal systems, *Journal of the irrigation and Drainage Division*, **102**, 40-47.
- Zadeh, L.A.**, 1967. Fuzzy Algorithms, Information and Control, New York : McGraw-Hill.
- Zaighum H., Shahid B.A. and Bhutta M.N.**, 1992. The utility of a simulation model for Pakistan canal system, Application Examples from North West Frontier Province and Punjab, *International Workshop on the Application of Mathematical Modelling for the Improvement of Irrigation Canal Operation*, Montpellier, France, October 26-29, 107-115.

APPENDIX A

Table A.1 Specification and location of particular type of experimental lining

Test #	Channel	Lining Type	Type of Lining	Geomembrane	Test Reach		Figure Ref no.
					From	To	
1	1R/3R	2a	T-shaped precast walls with in-situ concrete on bed overlain geomembrane on bed with sealed joints, with geotextile precast walls, 50 mm (2") in-situ bed without bed joints walls and bed only.	VLDPE	0+094	0+178	5.9
2	1R/3R	2c	T-shaped precast walls with 50 mm (2") in-situ concrete on bed with joints walls and bed without geomembrane and geotextile	No	0+183	0+270	5.9
3	1R/3R	2b	T-shaped precast walls with 50 mm (2") in-situ concrete on bed without joints sealed with geomembrane and geotextile	FPA	0+278	0+363	5.9
4	1R/3R	9	Tongued and grooved precast, 50 mm (2"), slabs of 914 mm (3 ft) bed in one piece with in-situ edge beam in larger canals without joints sealed and with geomembrane and geotextile.	FPA	1+268	2+200	5.7
5	1R/3R	5n	50 mm (2") insitu concrete without joints sealed and with textured geomembrane and no geotextile.	Textured	2+208	2+714	5.6
6	1R/3R	5cd	76 mm (3") insitu concrete without joints sealed and with textured geomembrane and no geotextile.	Textured	7+391	7+907	5.5
7	1R/3R	1b	Tongued and grooved slabs with geomembrane geotextile and no joint sealant	FPA	10+000	10+480	5.7
8	1R/3R	5b	76 mm (3") in-situ concrete with joints sealed, with no geomembrane and geotextile original modification of production lining	No	12+183	13+183	5.5
9	1R/3R	5c	76 mm (3") in-situ concrete without joints sealed, with geomembrane and geotextile original modification of production lining	FPA	15+353	17+046	5.6

APPENDIX A (Continued)

<i>Continued Table A.1 Specification and location of particular type of experimental lining</i>							
10	1R/3R	6	Bricks in mortar without joints sealed geomembrane and no geotextile	FPA	26+000	27+167	5.8
11	1R/3R	2b	T-shaped precast walls with 50 mm (2") in-situ concrete on bed without joints sealed with geomembrane and geotextile.	FPA	34+070	34+409	5.9
12	1R/3R	2c	T-shaped precast walls with 50 mm (2") in-situ concrete on bed with joints walls and bed without geomembrane and geotextile	No	34+414	34+501	5.9
13	1R/3R	2a	T-shaped precast walls with in-situ concrete on bed overlain geomembrane on bed with sealed joints, with geotextile precast walls, 50 mm (2") in-situ bed without bed joints walls and bed only.	FPA	34+504	34+545	5.9
14	1R/3R	1c	Tongued and grooved slabs with geomembrane, joint sealant and no textile	FPA	35+000	36+562	5.7
15	1R/3R	3b	Precast, 50 mm (2") plain slabs, mortar joints $Q < 0.28$ cms ($Q < 10$ cfs) without joints sealed with geomembrane and textile.	FPA	40+648	41+493	5.7
16	1R/3R	3a	Precast, 50 mm (2") plain slabs, mortar joints $Q < 0.28$ cms ($Q < 10$ cfs) without joints sealed with geomembrane and no textile	FPA	41+499	42+488	5.7
17	1R/3R	7	Tongued and grooved precast slabs of 914 mm (3 ft) bed in one piece without joints sealed and with geomembrane and geotextile.	FPA	46+000	46+200	5.7
18	1R (Bahadar wah)	4	Parabolic, with joints sealed not geomembrane and geotextile	No	2+750	4+292	5.10
19	3R Hakra Disty	op1	450 mm (1'-6") thick soil cover with geomembrane on bed only no geotextile and joint sealant	VLDPE	2+000	3+000	5.3
20	-	op3	Mattress filled with concrete minimum thickness 76 mm (3") concrete cover, without joint sealed and with geomembrane and geotextile	VLDPE	09+178	10+723	5.4
21	-	op2	600 mm (2 ft) thick soil cover with geomembrane on bed only no geotextile and joint sealant	VLDPE	24+941	25+750	5.3

APPENDIX A (Continued)

<i>Continued Table A.1 Specification and location of particular type of experimental lining</i>							
22	Najibwah Minor	5a	76 mm (3") in-situ concrete with joints sealed, with geomembrane and geotextile original modification of production lining	FPA	4+496	5+566	5.6
23	Shadab Minor	8	Tongued and grooved precast, 50 mm (2"), slabs of 914 mm (3 ft) bed in one piece in smaller canals without joints sealed and with geomembrane and geotextile but with in-situ edge beam	FPA	0+328	0+705	5.7
24	2L/3R (Khatan)	4lg	Parabolic, without joints sealed, with geomembrane and geotextile on a large canal	FPA	5+440	5+800	5.10
25	2L/3R (Khatan)	4l	Parabolic, with joints sealed not geomembrane and textile on a large canal	No	5+805	6+413	5.10

Table A.2 Summary of Technical Conclusions on Lining Types

Basic Lining Types	Ease of Construction	Water Tightness	Durability
Geomembrane on bed only, under soil cover (Type B)	Fair, difficult to avoid occasional tearing when replacing sand. High groundwater can make problems	Poor: even a perfect bed only lining is unlikely to reduce seepage by more than about 60 %	Probably good if sand cover is at least 50 mm (2 ft), doubtful with less cover
Geomembrane under soil cover on bed and banks (Type A)	Bed as above Banks time consuming problems arise if existing canal banks are narrow. Stability doubtful, needed careful refilling	Would probably be good if soil cover on banks remain intact	Doubtful. Probably fair if first two years survived and natural berm deposits re-established
Geomembrane under concrete filled mattress (Type I)	Fair, after initial learning period. Minimal earthworks needed, adoptable to regular shapes	Good. Serious damage to geomembrane during installation unlikely	Doubtful. Probably fair to good. Mattress could be damaged by heavy animal traffic near bank top.
Geomembrane under sand on bed and mattress on banks (Type N, not tested)	Fair, mattress on banks can be placed during closure but filled underwater in flowing canal	Probably good if ways found to avoid damaging geomembrane on bed during installation.	Probably fair to good; as Type I

APPENDIX A (Continued)

<i>Continued Table A.2 Summary of Technical Conclusions on Lining Types</i>			
Trapezoidal insitu concrete without geomembrane (Type 5b)	Fair. Requires extensive earthwork preparation, both compaction and trimming	Fair, depends on quality of joint sealant and its installation.	Poor, joint sealant vulnerable and needs good maintenance.
Geomembrane under insitu concrete (Type 5c)	Fair. Require extensive earthwork preparation, both compaction and trimming. Placing of Geosynthetics not difficult if geomembrane sufficiently flexible	Good, Geotextile provided to prevent slipping of concrete, but also protects geomembrane during installation	Good water tightness provided by geomembrane which is not exposed, no reliance on joint sealing
Geomembrane under precast concrete trapezoidal (Type 9)	Fair. Require extensive earthwork preparation, both compaction and trimming. Precasting of plain slabs easy. Placing of slabs needs care. Variant Type I (interlocking pieces) difficult. Requires large scale to make good precasting economic	Potentially good if enough care taken to avoid puncturing geomembrane during installation use of geotextile helps this.	Fair to good; some chance of damage to geomembrane by vandalism via cracks between slabs (danger reduced if joints mortared) Variant Type 3b vulnerable to theft because no edge beam.
Geomembrane under mortared brickwork (Type 6)	Fair. Requires extensive earthwork preparation, both compaction and trimming. Placing of bricks very slow.	Good. Geotextile not needed.	Probably good. Bricks on edge difficult to remove and easy to replace or repair. Alternative tiles not so good.
Vertical precast walls, insitu bed (Type 2b)	In principle easy; needs little earthwork preparation, and no bank trimming. Like some other types, needs a learning process for installation. Has advantage where access is restricted.	Expected to be good (with geomembrane to bank top level in, Type 2b: poor for Type 2a, fair for Type 2c)	Probably good. High resistance to theft or tempering, geomembrane very well covered.
Geomembrane under precast parabolic channel (Type 4g)	Precasting and handling difficult, except when scale permits factory type precasting as, in Mediterranean countries. Installation fairly easy, even with limited	Good, with geomembrane. Fair for variant Type 4 with no geomembrane because of reliance on numerous scaled joints.	Fair to poor. Geomembrane may be vulnerable to objects poked through joints. Type 4, with no geomembrane, vulnerable to loss of joint sealant.

APPENDIX A (Continued)

Table A.3 Standard canal sized for cost comparison

Typical Discharge	Longitudinal Slope	Shape	Side Slope	Water Depth	Bed width	Water surface width	Width/depth ratio	Manning's
(m ³ /sec)			V:H	D (m)	B (m)	W (m)	W/D	(n)
0.26 (9 cfs)	1 in 3,700	Type 5	1:1	0.50	0.60	1.60	3.2	0.015
		Type 9	1:1	0.45	0.90	1.81	4.0	0.017
0.85 (30 cfs)	1 in 5,500	Type 5	1:1.5	0.62	1.82	3.68	6.0	0.015
		Type 9	1:1	0.63	2.28	3.54	5.6	0.017
		Type 2	1:0.062	0.70	2.35	2.43	3.5	0.015
2.83 (100 cfs)	1 in 8,230	Type 5	1:1.5	1.05	3.05	6.19	5.9	0.015
		Type 9	1:1	1.10	3.65	5.84	5.3	0.017
		Type 2	1:0.062	0.90	5.33	5.45	6.0	0.015
9.43 (333 cfs)	1 in 12,230	B,M,I, N	1:1	1.37	12.50	15.24	11.0	0.020
		Type A	1:1.5	1.37	11.89	16.15	11.7	0.020

Table A.4 Summary of relative costs of some lining types for canals carrying up to 2.83 m³/sec (100 cfs)

<i>Comparison for 0.26 cms (9 cfs) Canal size</i>						
Brick	Insitu concrete			Precast concrete slabs		
Type-6 with diversion	Type-5c with diversion	Type-5b with diversion	Type-5n with diversion	Type-9 with diversion	Type-9 without diversion	Type-9 without diversion no geotextile
Costs in Pak Rupees per meter of canal at January 1999						
2027	1994	1872	1774	2378	2036	1872
Costs USD per meter of canal at January 1999.						
40.54	39.88	37.44	35.48	47.56	40.72	37.44
Costs per unit canal length relative to type-5c						
102%	100%	94%	89%	119%	102%	94%

APPENDIX A (Continued)

Continued Table A.4 Summary of relative costs of some lining types for canals carrying up to 2.83 m³/sec (100 cfs)

Comparison for 0.85 cms (30cfs) Canal size										
Brick	In-situ concrete			Precast concrete slabs			Precast near vertical walls, in situ bed			
Type 6 with div.	Type 5c with div.	Type 5b with div.	Type 5n with div.	Type 9 with div.	Type 9 with div.	Type 9 without div.	Type 2b with div.	Type 2b without div.	Type 2b with div.	Type 2b with div.
Costs in Pak Rupees per meter of canal at January 1999 prices										
3894	3847	3205	3424	4004	3450	3145	6986	6432	6504	5851
Costs in USD per meter of canal at January 1999 prices										
77.88	76.94	64.10	68.48	80.08	69	62.9	139.72	128.64	130.08	117.02
Costs per unit length relative to Type-5c										
101%	100%	83%	89%	104%	90%	82%	182%	167%	169%	152%

Comparison for 2.83 cms (100 cfs) Canal size										
Brick	Insitu concrete			Precast concrete slabs			Precast near vertical walls, in situ bed			
Type 6 with div.	Type 5c with div.	Type 5b with div.	Type 5n with div.	Type 9 with div.	Type 9 with div.	Type 9 without div.	Type 2b with div.	Type 2b without div.	Type 2b with div.	Type 2b with div.
Costs in Pak Rupees per meter of canal at January 1999 prices										
5927	5884	4690	5270	6077	5225	4753	9922	9069	9285	8216
Costs in USD per meter of canal at January 1999 prices										
118.54	117.68	93.8	105.4	121.54	104.50	95.06	198.44	181.38	185.70	164.32
Costs per unit length relative to Type-5c										
101%	100%	80%	90%	103%	89%	81%	169%	154%	158%	140%

* div : diversion

APPENDIX A (Continued)

Table A.5 Summary of Technical and Comparison of Lining Types

Basic lining types	Ease of construction	Water tightness	Durability	Cost (US \$)
Geomembrane on bed only, under soil cover (Type B)	Fair,	Poor: is unlikely to reduce seepage by more than about 60 %	Probably good for deeper canals only.	Cheap, both per unit length and per unit area. (US\$ 5 per m ² . of the bed area)
Geomembrane under soil cover on bed and banks (Type A)	Poor	Would probably be good if soil cover on banks remain intact	Doubtful.	Cheaper than Type N unless Type N uses cheap local fabric; around US\$ 11/ m ²
Geomembrane under concrete filled mattress (Type I)	Fair	Good.	Probably fair to good. For deeper canals only	Very expensive, almost US\$ 30/ m ² , unless using local fabric.
Geomembrane under sand on bed and mattress on banks (Type N, not tested)	Fair,	Probably good	Probably fair to good for deeper canals only.	Fairly expensive, about US\$ 18/ m ² , unless using local fabric.
Trapezoidal insitu concrete without geomembrane (Type 5b)	Fair. Extensive earth work preparation,	Fair, depends on joint sealant.	Poor, sealed joint vulnerable and needs good maintenance.	20 % cheaper than Type 5c for 2.85 cms (100cfs); closer for small canals.
Geomembrane under insitu concrete (Type 5c)	Fair. Extensive earthwork preparation,	Potentially Good.	Good.	Fairly expensive, US\$ 16 to 18 / m ² for small canals.
Geomembrane under precast concrete trapezoidal (Type 9)	Fair. Extensive earthwork preparation. Requires large scale to make good precasting economics.	Good	Fair to good;	Slightly dearer than Type 5c, but just cheaper if diversion channel can be avoided.
Geomembrane under mortared brickwork (Type 6)	Fair. Placing of bricks very slow.	Good.	Probably good.	Similar cost to Type 5c.
Vertical precast walls, insitu bed (Type 2b)	In principle easy; Has advantage where access is restricted.	Expected to be good	Probably good.	Much more expensive than trapezoidal types, about US\$ 27 to 40/ m ²

APPENDIX A (Continued)

<i>Continued Table A.5 Summary of Technical and Comparison of Lining Types</i>				
Geomembrane under precast parabolic channel (Type 4g)	Precasting and handling difficult, Installation fairly easy, even with limited access.	Good, with geomembrane.	Fair to poor.	(Not analysed)

Table A.6 Total water seepage for pre and post canal lining through ponding tests under production component

Sr. No.	Channels	Length	Discharge	Wetted Area	Pre Lining Seepage		Post Lining Seepage		Reduction
					cms/msm	mm/day	cms/msm	mm/day	
1	Girdariwala Minor	4.7	0.40	0.014	0.69	59.68	0.02	1.76	97
2	Bhaku Shah	0.8	0.20	0.001	0.91	78.99	0.00	0.00	100
3	Bahadarwah Minor	18.5	2.63	0.138	0.71	60.97	0.03	2.65	96
4	1-R Bahawarwah Minor	1.5	0.11	0.002	0.91	78.99	0.15	13.17	83
5	Najibwah Minor	5.4	1.19	0.038	0.43	37.25	0.06	5.14	86
6	1-R Sunder disty	3.7	0.71	0.012	0.68	58.74	0.07	6.08	90
7	2-R Dunga Disty	10.3	0.62	0.032	0.70	60.40	0.02	1.55	97
8	1-R/3R	16.2	2.18	0.107	0.61	52.43	0.10	8.47	84
9	Bhukan Minor	5.4	0.40	0.015	0.71	60.89	0.06	4.94	92
10	1-L/3R	10.3	0.85	0.042	0.86	74.31	0.02	1.76	98
11	2-L/3R	2.0	0.28	0.005	0.73	63.19	0.12	10.53	83
12	4-R haroonabad	12.1	1.50	0.082	0.73	63.13	0.02	1.50	98
13	1RA/4R	6.7	0.76	0.029	0.71	61.15	0.02	1.70	97
14	1R/4R	15.5	1.42	0.072	0.70	60.87	0.04	3.08	95
15	1-L/Hakra	23.8	2.09	0.178	0.71	60.93	0.02	1.52	98
16	Shadab Minor	1.6	0.10	0.002	0.91	78.99	0.00	0.00	100
17	3-R Khatan Disty	10.4	8.69	0.311	0.53	45.90	0.02	1.65	96
17a	3-R Khatan Disty	11.0	2.24	0.077	0.82	71.06	0.02	1.59	98
Avg.			1.46			56.66		2.67	

APPENDIX A (Continued)

Table A.7 Seepage comparison between different measuring techniques

Sr. No.	Channels	Length	Discharge	Wetted Area	Ponding Seepage		In-outflow Seepage		% Difference
		L(km)	Q(cms)	A(msm)	cfs/msf	mm/day	cfs/msf	mm/day	%
1	Girdariwala Minor	4.73	0.35	13.01	2.28	60.04	6.20	163.28	172
2	Najibwah Minor	17.17	1.11	75.29	1.40	36.87	6.67	175.65	376
3	Bahadarwah Minor	18.29	2.32	115.26	2.28	60.04	6.20	163.28	172
4	1-R Bahawarwah Minor	1.68	0.10	2.79	2.65	69.79	6.20	163.28	134
5	Bhukan Minor	7.01	0.40	12.08	2.28	60.04	6.20	163.28	172
6	Shadab Minor	1.62	0.10	2.79	2.28	60.04	3.00	79.00	32
7	Bhaku Shah Disty	1.75	0.17	1.86	2.28	60.04	6.20	163.28	172
8	1-R Sunder Disty	3.66	0.54	11.15	2.28	60.04	6.20	163.28	172
9	2-R Dunga Disty	10.89	0.57	36.25	2.28	60.04	6.20	163.28	172
10	3-R Khatan Disty	49.70	8.70	446.16	1.88	49.51	7.73	203.57	311
11	1-R/3R Qaziwala disty	17.99	1.70	93.88	2.04	53.72	3.69	97.18	81
12	1-L/3R Minor	10.34	0.77	40.90	3.31	87.17	5.61	147.74	69
13	2-L/3R Minor	3.05	0.28	5.58	2.28	60.04	6.20	163.28	172
14	4-R Haroonabad Disty	12.20	1.16	61.35	2.41	63.47	6.73	177.23	179
15	1RA/4R Minor	6.71	0.79	25.10	2.28	60.04	6.20	163.28	172
16	1R/4R Minor	15.40	1.42	53.91	2.28	60.04	6.20	163.28	172
17	1-L/Hakra Disty	23.78	1.90	158.02	2.28	60.04	6.20	163.28	172
Avg.		12.11	1.32			60.06		157.44	171

APPENDIX A (Continued)

Table A.8 Statistical analysis of seepage using ponding and inflow-outflow measuring techniques

channel #	Channels	Mean Seepage		Mean Std Devi		C. Variation		Mean standard error		95 % confi. Level	
		in-out	Pond	in-out	Pond	in-out	Pond	in-out	Pond	in-out	Pond
		mm/day	mm/day	mm/day	mm/day	%	%	mm/day	mm/day		
2	Najibwah	175.65	36.87	15.01	1.84	9.00	4.93	5.27	0.26	163 - 188	36 - 37
4	1R Bahadarwah		69.79		5.00		7.20		0.79		68 - 71
10	3R Hakra Disty	203.57	49.51	30.81	4.48	15.14	8.33	14.75	0.79	252 - 322	48 - 50
11	1R/3R Qaziwala Minor	97.18	53.72	20.80	2.11	21.41	3.63	6.32	0.26	123 - 153	53 - 54
12	1L/3R Jourkanwala Minor	147.74	87.43	31.07	5.79	21.03	7.56	17.12	1.32	182 - 203	84 - 90
14	4R Haroonabad Disty	172.76	63.47	23.17	2.11	13.42	3.50	13.69	0.26	184 - 232	63 - 65

Table A.9 Prediction of additional water availability based on ponding and in-outflow tests

Sr. No.	Channels	Length	Discharge			Ponding			Inflow - Outflow		
			L(km)	cms	hec-m/day	cfs/msf	mm/day	hec-m/day	cfs/msf	mm/day	hec-m/day
1	Girdariwala Minor	4.73	0.35	3.02	2.28	60.04	0.08	6.20	163	0.21	
2	Najibwah Minor	17.17	1.11	9.42	1.40	36.87	0.27	6.67	175	1.31	
3	Bahadarwah Minor	18.29	2.32	19.80	2.28	60.04	0.68	6.20	163	1.86	
4	1-R Bahawarwah Minor	1.68	0.10	0.86	2.65	69.79	0.02	6.20	163	0.05	
5	Bhukan Minor	7.01	0.40	3.38	2.28	60.04	0.07	6.20	163	0.20	
6	Shadab Minor	1.62	0.10	0.85	2.28	60.04	0.02	3.00	79	0.05	

APPENDIX A (Continued)

7	Bhaku Shah Disty	1.75	0.17	1.45	2.28	60.04	0.01	6.20	163	0.03
8	1-R Sunder Disty	3.66	0.54	4.59	2.28	60.04	0.07	6.20	163	0.18
9	2-R Dunga Disty	10.89	0.57	4.83	2.28	60.04	0.22	6.20	163	0.59
10	3-R Khatan Disty	49.70	8.70	74.13	1.88	49.51	2.18	7.73	203	8.97
11	1-R/3R Qaziwala disty	17.99	1.70	15.94	2.04	53.72	0.50	3.69	97	0.90
12	1-L/3R Minor	10.34	0.77	6.52	3.31	87.17	0.35	5.61	147	0.60
13	2-L/3R Minor	3.05	0.28	2.41	2.28	60.04	0.03	6.20	163	0.09
14	4-R Haroonabad Disty	12.20	1.16	9.90	2.41	63.47	0.39	6.73	177	1.07
15	1RA/4R Minor	6.71	0.79	6.76	2.28	60.04	0.15	6.20	163	0.40
16	1R/4R Minor	15.40	1.42	12.07	2.28	60.04	0.32	6.20	163	0.87
17	1-L/Hakra Disty	23.78	1.90	16.18	2.28	60.04	0.94	6.20	163	2.55
	per year			56,669.50			1,855.55			5,876.40

* *hec-m/day* = hectare-meter per day

Table A.10 Input and output data for the Fuzzy Model LAQ-Sp

Input Data				Rules				Output Data					
L	WA	Q	Sp(Ob)					Trial-1		Trial-2		Trial-3	
(km)	(km ²)	(cms)	(mm/day)	L	WA	Q	Sp	Sp(Pr)	%Rsp	Sp(Pr)	%Rsp	Sp(Pr)	%Rsp
4.73	13.01	0.397	60	VL	VL	VL	M	68.22	12.01	67.94	11.64	67.94	11.64
17.17	75.29	1.190	37	H	M	M	VL	34.97	5.14	34.97	5.14	34.97	5.14
18.29	115.26	2.635	60	H	H	H	M	55.28	7.92	55.28	7.92	55.28	7.92
1.68	2.79	0.113	79	VL	VL	VL	H	68.89	12.80	68.89	12.80	68.89	12.80
7.01	12.08	0.397	60	L	VL	VL	M	40.00	33.37	65.00	7.64	65.00	7.64
1.62	2.79	0.099	79	VL	VL	VL	H	68.90	12.79	68.90	12.79	68.90	12.79
1.75	1.86	0.198	79	VL	VL	VL	H	68.88	12.81	68.88	12.81	68.88	12.81
3.66	11.15	0.708	59	VL	VL	L	L	40.00	32.20	50.00	15.25	50.00	15.25
10.89	36.25	0.623	60	M	L	L	M	68.30	12.11	68.30	12.11	68.30	12.11
49.70	446.16	8.700	50	H	H	H	L	55.68	10.20	55.68	10.20	55.68	10.20
17.99	93.88	2.182	52	H	M	H	L	34.50	33.66	44.66	14.11	44.66	14.11
10.34	40.90	0.850	74	M	L	L	H	68.56	7.36	68.56	7.36	68.56	7.36
3.05	5.58	0.283	63	VL	VL	VL	M	68.68	8.28	68.68	8.28	68.68	8.28
12.20	61.35	1.502	63	M	M	M	M	40.00	36.96	40.00	36.96	65.01	2.39
6.71	25.10	0.765	61	L	L	L	M	64.80	5.86	64.80	5.86	64.80	5.86

Continued Table A.10 Input and output data for the Fuzzy Model LAQ-Sp

APPENDIX A (Continued)

15.40	53.91	1.417	61	H	M	M	M	57.40	5.90	57.40	5.90	57.40	5.90
23.78	158.02	2.097	61	H	H	H	M	55.24	9.45	55.55	8.94	55.55	8.94
				Average error (%)				15.22		11.51		9.48	

*Sp(pr) = predicted seepage by ponding method, Rsp=relative error between observed and predicted seepage values

Table A.11 Input and output data for the Fuzzy Model LAQ-Si

Input Data				Rules				Output results					
L	WA	Q	Si (ob)					Trial-1		Trial-2		Trial-3	
(km)	(km ²)	(cms)	(mm/day)	L	WA	Q	Si	Si(Pr)	Rsi	Si(Pr)	Rsi	Si(Pr)	Rsi
4.73	13.01	0.354	163	VL	VL	VL	M	146.49	10.26	146.5	10.26	155.53	4.73
17.17	75.29	1.105	176	H	M	M	M	109.73	37.52	109.7	37.52	189.13	7.14
18.29	115.26	2.324	163	H	H	H	M	189	13.63	188.8	13.55	189.61	13.90
1.68	2.79	0.101	163	VL	VL	VL	M	147.15	9.86	147.2	9.86	155.78	4.57
7.01	12.08	0.397	163	L	VL	VL	M	164.95	1.03	165	1.033	175.25	6.85
1.62	2.79	0.099	158	VL	VL	VL	L	147.15	6.86	147.2	6.855	155.78	1.39
1.75	1.86	0.170	163	VL	VL	VL	M	147.15	9.86	147.2	9.86	155.74	4.60
3.66	11.15	0.538	163	VL	VL	L	M	146.19	10.45	146.2	10.45	171.4	4.76
10.89	36.25	0.567	163	M	L	L	M	145.47	10.89	145.5	10.89	155.18	4.94
49.70	446.16	8.700	204	H	H	H	H	193.52	4.92	194.4	4.481	194.9	4.24
17.99	93.88	1.700	197	H	M	M	H	109.39	44.52	109.4	44.51	189.45	3.91
10.34	40.90	0.765	148	M	L	L	L	146.31	0.95	146.3	0.949	155.53	5.03
3.05	5.58	0.283	163	VL	VL	VL	M	147.16	9.85	147.2	9.854	155.64	4.66
12.20	61.35	1.162	177	M	M	M	H	160.58	9.38	160.6	9.38	163.21	7.90
6.71	25.00	0.793	163	L	VL	L	M	164.97	1.05	165	1.045	175.36	6.91
15.40	53.91	1.417	163	H	M	M	M	146.28	10.39	146.3	10.39	164.94	1.03
23.78	158.02	1.899	163	H	H	M	M	164.97	1.05	165	1.045	175.36	6.91
			Average error (%)						11.32		11.29		5.50

APPENDIX A (Continued)

Table A.12 Summary of test results of geomembranes

Geosynthetics Materials	Code	Material Thickness	Slow Puncture Test Tapered Probe FTMS 101C 2065.1	Slow Puncture Test 8 mm Probe ASTM D 4833	Slow Puncture Test Over water ASTM D 5494 A	Slow Puncture Test Over water ASTM D 5494 B	Hydrostatic Cone Test Critical Cone Height ASTM D 5514	Tensile Strength Test Dumbell Test ASTM D 638	Shear Strength Test 25 mm seamed strip ASTM D 638	Peeling Strength Test 25 mm seamed strip ASTM D 638	Graves Tear Test ASTM D 624 die-C	Flexibility/Stiffness ASTM D 1388
			T (mm)	A (N)	B (N)	C (N)	D (N)	N(mm)	F (N/mm ²)	G(N/mm ²)	H N/mm ²)	i (N)
HDPE SGS	111	0.51	140	295	204	67	13	15	20	14	67	218
HDPE CBC	112	1.31	307	521	377	230	15	19	18	9	159	394
HDPE SGS	113	1.59	338	548	862	715	13	22	23	15	222	490
HDPE SGS	114	0.79	189	402	394	161	15	23	20	11	111	348
LDPE SGS	121	0.79	173	289	444	53	35	11	14	9	74	226
LDPE Lahore clear sample	122	0.86	150	273	731	147	17	14	12	9	92	267
LDPE Lahore black sample	124	0.98	177	333	543	197	15	14	13	7	103	268
LDPE 0.30 mm (IRI)	123	0.3	39	105	75	32	3	7			26	117
VLDPE SGS	131	1.07	295	332	611	95	45	22	11	7	109	249
VLDPE SGS	132	1.26	355	385	897	161	15	20	13	10	121	282
VLDPE	133	0.76	255	266	901	80	80	24	20	14	40	239
VLDPE "polyfex" Hussain JV	134	0.49	111	154	289	80		7	11	10	50	168
VLDPE "Duraflex" polyfex	135	0.3	105	112	252	40		7			22	124
VLDPE "Duraflex" polyfex	136	0.49	146	187	353	68	65	15	14	10	43	163
VLDPE "Duraflex" polyfex	137	0.95	186	238	622	203	55	20	11	8	84	231

APPENDIX A (Continued)

<i>Continued Table A.12 Results Summary of geosynthetics materials by new grouping technique</i>												
Carbofol Naue Fasertechnik	161	1.13	219	423	503	358	15	25	16	14	154	378
Carbofol Naue Fasertechnik	171	1.75	333	616	931	802	15	26	18	13	257	490
HDPE/LLDPE/LDPL, Urumchi	181	0.52	98	192	377	71		13			59	203
HDPE/LLDPE/LDPL, Urumchi	182	0.66				108		12	16	12	81	145
Textured PE	191	1.5	227	420	421	159	15	8	17	4	152	371
FPA 0.50 mm for Field exp.	211	0.52	122	116	252	30	80	13	14	4	40	130
FPA SGS	212	0.57	157	171	243	25		13	13	4	40	127
FPA SGS	213	0.7	183	211	249	55	87	13	8	6	50	150
FPA SGS	214	1.05	224	271	390	100	55	17	11	6	86	201
GSE from hussain JV	310	0.51	151	178	424	62		12	11	9	47	149
Tender sample (Ultraflex)	311	0.5	167	190	401	77		8	14	11	52	156
Tender sample (Ultraflex)	312	0.51	146	230	542	80		20	17	12	58	180
Unlabeled sample (Hussain JV)	331	0.53	134	238	462	74		15			45	179
Unlabeled, clear, china chengdu	332	0.22	48	82	69	24		7			17	99
PVC CBC	341	0.81	206	316	709	53	80	16	16	8	51	99
EMDM CBC	421	1.8	241	337	1213	163	65	11	10	5	97	236
Unknown from CBC	441	1.02	135	162	538	153	55	14	10	8	66	211
Mizu sheet, from IRI	511	1.23	150	324	650	124	45	6			44	135
Unknown material	513	1.07	244	529	980	251		12			77	196
Unreinforced three colours	514	0.25	152	222	71	104		10			33	132

APPENDIX A (Continued)

<i>Continued Table A.12 Results Summary of geosynthetics materials by new grouping technique</i>												
Reinforced Polypropylene	516	0.73	494	1014	836	401		30	38	5	145	221
Composite, China Chendgu,	610	1.35	414	625		272	5	3			56	131
Composite, China Chendgu,	611	1.39	402	644	37	297		2			96	136
Composite, China Chendgu,	612	1.22	401	611	38	287		3			62	126
Composite, China Chendgu,	613	1.37	375	691	39	297		2			78	163

Table A.13 Statistical parameters of geosynthetics testing variables

Parameters	T	A	B	C	D	N	F	G	H	i	K
Max	1.80	494.20	1013.80	1213.20	802.00	87.00	29.83	37.81	14.59	256.60	490.00
Min	0.22	38.80	82.00	37.00	24.50	3.00	1.90	8.00	3.85	16.80	99.00
Median	0.80	182.50	289.20	422.15	115.40	26.00	13.26	13.86	8.86	66.40	188.00
Mode	0.51		238.30		59.00	15.00			5.71	40.30	99.00
Average	0.88	214.97	339.81	471.69	176.15	37.63	13.76	15.33	9.08	81.52	213.20
S. Dev	0.42	107.62	200.51	297.96	168.35	27.84	6.99	5.78	3.24	51.84	99.54
Skewness	0.40	0.79	1.28	0.46	2.28	0.46	0.24	2.27	0.11	1.61	1.37
Kurtosis	-0.71	0.00	1.92	-0.32	5.95	-1.34	-0.48	7.73	-0.97	2.96	1.46

T:Thickness,

B:Slow puncture test (8 mm probe)

D:Pyramid over aluminum

F:Tensile strength test

H:Seamed peeling test

A:Slow puncture test (Tapered probe),

C:Pyramid over water

N:Hydrostatic cone puncture test

G:Seamed shear test

K:Stiffness/flexibility test

APPENDIX A (Continued)

Table A.14 Results Summary of geosynthetics materials by new grouping technique

Geosynthetics Materials	Code	Material Thickness	Flexibility/Stiffness ASTM D 1388	Relative Stiffness K-150*T	Slow Puncture Test Tapered Probe FTMS 101C-2065.1	Slow Puncture Test 8 mm Probe STM D 4833	Slow Puncture Test Over water ASTM D 5494 A	Slow Puncture Test Over water ASTM D 5494 B	Hydrostatic Cone Test Critical Cone Height ASTM D 5514	Tensile Strength Test Dumbell Test ASTM D 638	Shear Strength Test 25 mm seamed strip ASTM D 638	Peeling Strength Test 25 mm seamed strip ASTM D 638	Graves Tear Test ASTM D 624 die-C
		T (mm)	K (mm)	RS (mm)	A (N)	B (N)	C (N)	D (N)	N (mm)	F (N/mm ²)	G (N/mm ²)	H (N/mm ²)	I(N)
Very stiff geomembranes (RS over 180mm)													
HDPE SGS	113	1.59	490	252	338	548	862	715	13	22	23	46	222
HDPE SGS	114	0.79	348	230	189	402	394	166	15	23	20	35	111
Carbofol from Naue Fasertechnik	171	1.75	490	228	333	616	931	802	15	26	18	41	257
Carbofol from Naue Fasertechnik	161	1.13	378	209	219	423	503	361	15	25	16	44	154
HDPE CBC	112	1.31	394	198	307	521	377	253	15	19	18	27	159
Stiff geomembranes (RS 120mm to 180mm)													
Textured PE	191	1.5	371	146	227	420	421	159	15	8	17	13	152
HDPE SGS	111	0.51	218	142	140	295	204	77	13	15	20	44	67
LDPE Lahore clear sample	122	0.86	267	138	150	273	731	162	17	14	12	27	92
HDPE/LLDPE/LDPL, Urumchi	181	0.52	203	125	98	192	377	71		13			59
VLDPE	133	0.76		125	255	266	901	80	80	24	20	43	40
LDPE Lahore black sample	124	0.98	268	121	177	333	543	197	15	14	13	23	103
Intermediate geomembranes (RS 60mm to 120mm)													
Reinforced Polypropylene	516	0.73	221	112	494	1014	836	401		30	38	17	145

APPENDIX A (Continued)

<i>Continued Table A.14 Results Summary of geosynthetics materials by new grouping technique</i>													
LDPE SGS	121	0.79	226	108	173	289	444	59	35	11	14	28	74
Tender sample Ultraflex	312	0.51	180	104	146	230	542	84		20	17	37	58
Unlabeled sample (Hussain JV)	331	0.53	179	100	134	238		77		15			45
Unreinforced three colours	514	0.25	132	95	152	222	71	121		10			33
VLDPE "polyfex" Hussain JV	134	0.49	168	95	111	154	289	104		7	11	31	50
Unreinforced three colours	514	0.25		95	152	222	71	121		10			33
VLDPE SGS	132	1.26	282	93	355	385	897	170	15	20	13	31	121
VLDPE "Duraflex" (polyfex)	136	0.49	163	90	146	187	353	89	65	15	14	31	43
VLDPE SGS	131	1.07	249	89	295	332	611	99	45	22	11	22	109
VLDPE "Duraflex" (polyfex)	137	0.95	231	89	186	238	622	209	55	20	11	26	84
Tender sample (Ultraflex)	311	0.5	156	81	167	190	401	77		8	14	35	52
VLDPE "Duraflex" (polyfex)	135	0.3	124	79	105	112	252	44		7			22
GSE from hussain JV	310	0.51	149	73	151	178	424	68		12	11	29	47
LDPE 0.30 mm (IRI)	123	0.3	117	72	39	105	75	32	3	7			26
Unlabeled,clear, china chengdu	332	0.22	99	66	48	82	69	31		7			17
Flexible geomembranes (RS 0 to 60mm)													
Unknown from CBC	441	1.02		58	135	162	538	160	55	14	10	25	66
FPA 0.50 mm for Field exp.	211	0.52	130	52	122	116	252	30	80	13	14	12	40

APPENDIX A (Continued)

<i>Continued Table A.14 Results Summary of geosynthetic materials by new grouping technique</i>													
HDPE/LLDPE/LDPL , Urumchi	182	0.66	145	46				110		12	16	38	81
FPA SGS	213	0.7	150	45	183	211	249	63	87	13	8	18	50
FPA SGS	214	1.05	201	44	224	271	390	110	55	17	11	18	86
FPA SGS	212	0.57	127	42	157	171	243	25		13	13	13	40
Very Flexible geomembranes (RS below 0)													
PVC CBC	341	0.81	99	-23	206	316	709	59	80	16	16	25	51
EMDM CBC	421	1.8	236	-34	241	337	1213	164	65	11	10	16	97
Mizu sheet, from IRI	511	1.23	135	-50	150	324	650	135	45	6			44
Composite geomembranes													
Composite, China Chendgu	610	1.35	131	-72	414	625		340	5	3			56
Composite, China Chendgu	611	1.39	136	-73	402	644	37	318		2			96
Composite, China Chendgu	612	1.22	126	-57	401	611	38	227		3			62
Composite, China Chendgu	613	1.37	163	-43	375	691	39	341		2			78

APPENDIX –A (Continued)

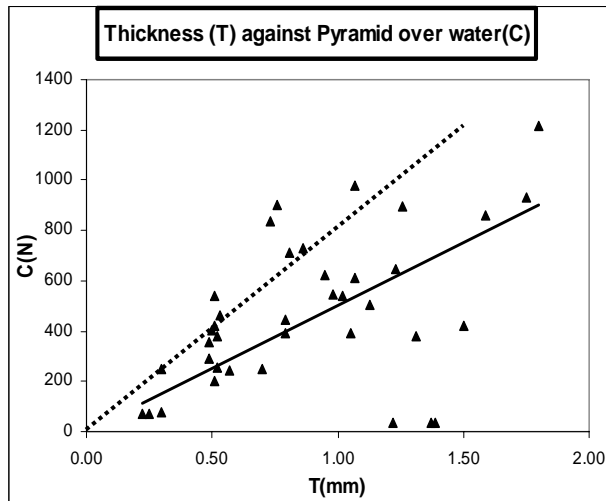

- ❖ Some correlation, most semi-crystalline geomembranes in wide band
- ❖ Reinforced geomembranes in or near the same band.
- ❖ Very flexible geomembranes in the same band, except EPDM showing higher puncture resistance.
- ❖ Composites show very low puncture resistance

Figure A.4 Graph between thickness and pyramid over water

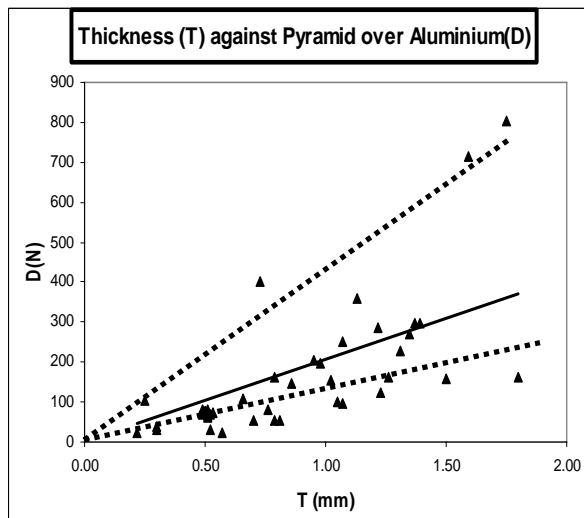

- ❖ *Some correlation: most semicrystalline polymers in a band, except one thick HPDE and thick Corbofol.*
- ❖ *Some grouping within the band: VLDPE mostly showing higher resistance, FPA mostly lower*
- ❖ *Very flexible geomembranes near the band on the low resistance side.*
- ❖ *Composites within the band on higher side*

Figure A.5 Graph between thickness and pyramid over aluminium

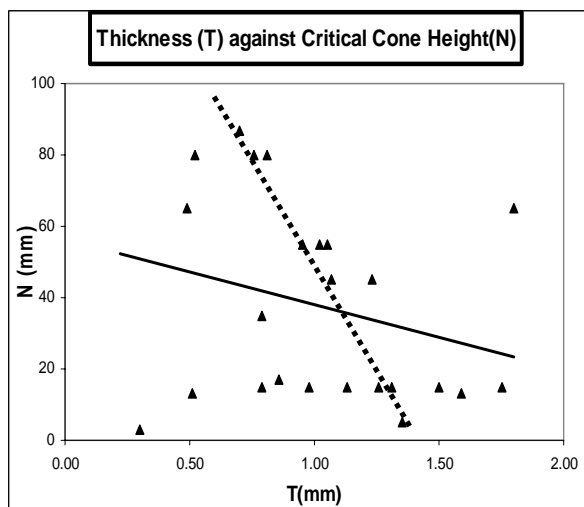

- ❖ *Little negative correlation or no correlation*

Figure A.6 Graph between thickness and critical cone height

APPENDIX –A (Continued)

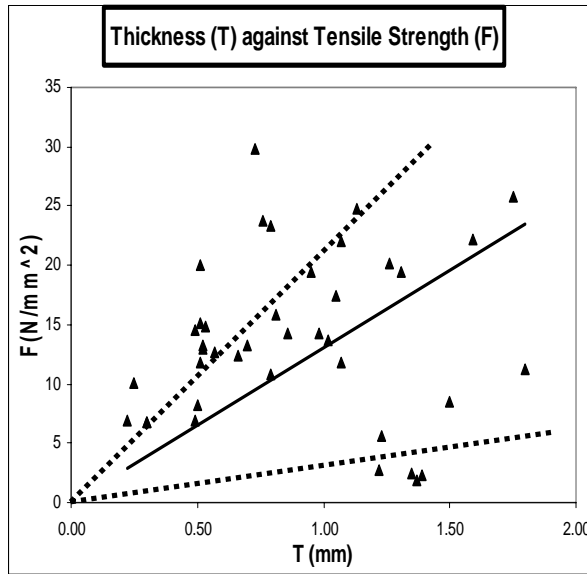

- ❖ Significant correlation, all semicrystalline geomembranes in a fairly narrow band.
- ❖ Reinforced geomembranes showing tensile strength within or above the band.
- ❖ Very flexible geomembranes showing tensile strength well below the band, except PVC.
- ❖ Composite showing very low tensile strength

Figure A.7 Graph between thickness and tensile strength

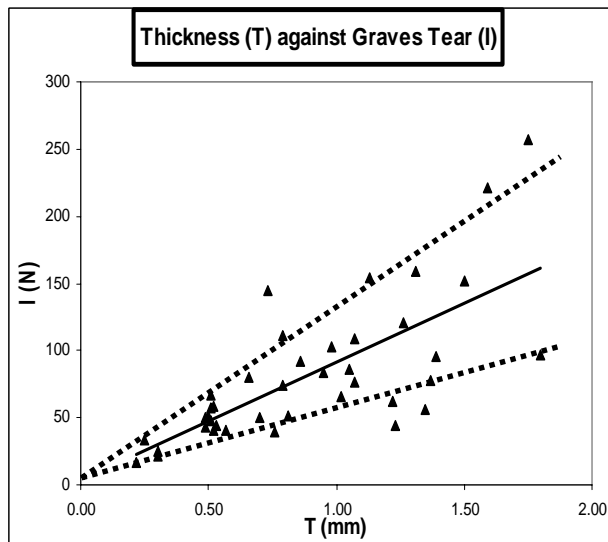

- ❖ Significant correlation, all semicrystalline geomembranes in a band.
- ❖ Reinforced geomembranes showing tear resistance within or above the band.
- ❖ Very flexible geomembranes showing tear resistance well below the band, except PVC.
- ❖ Composite showing very low tear resistance

Figure A.8 Graph between thickness and tear strength

APPENDIX –A (Continued)

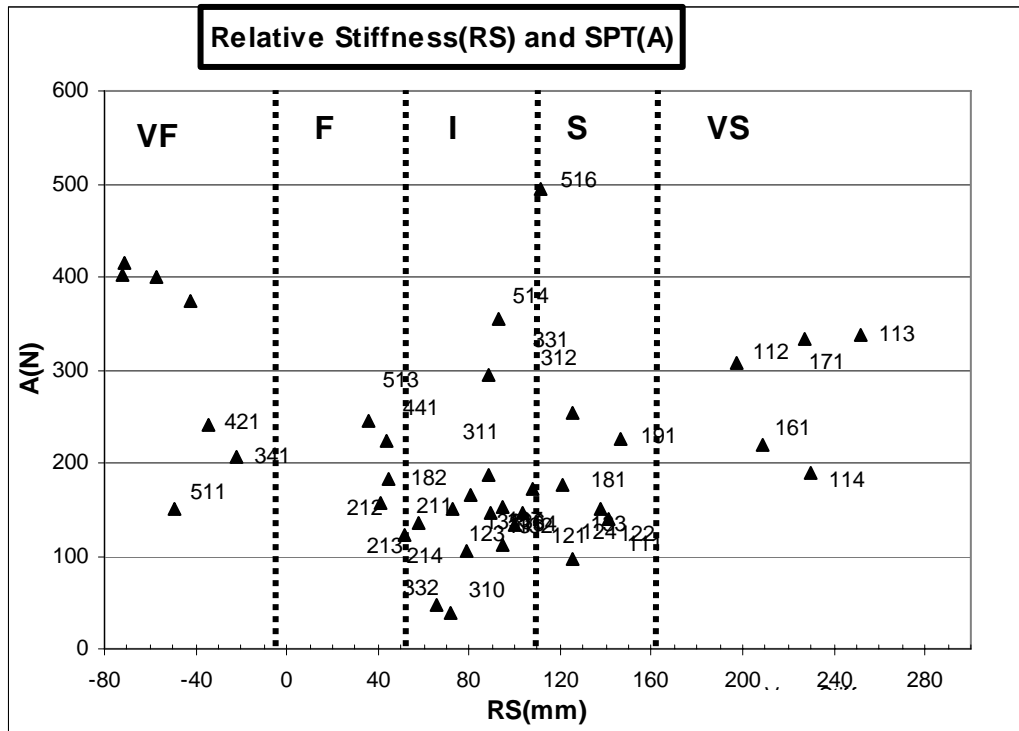

Figure A.9 Graph between relative stiffness (RS) and Tapered Probe (A)

❖ Little or no relation (Composite omitted)

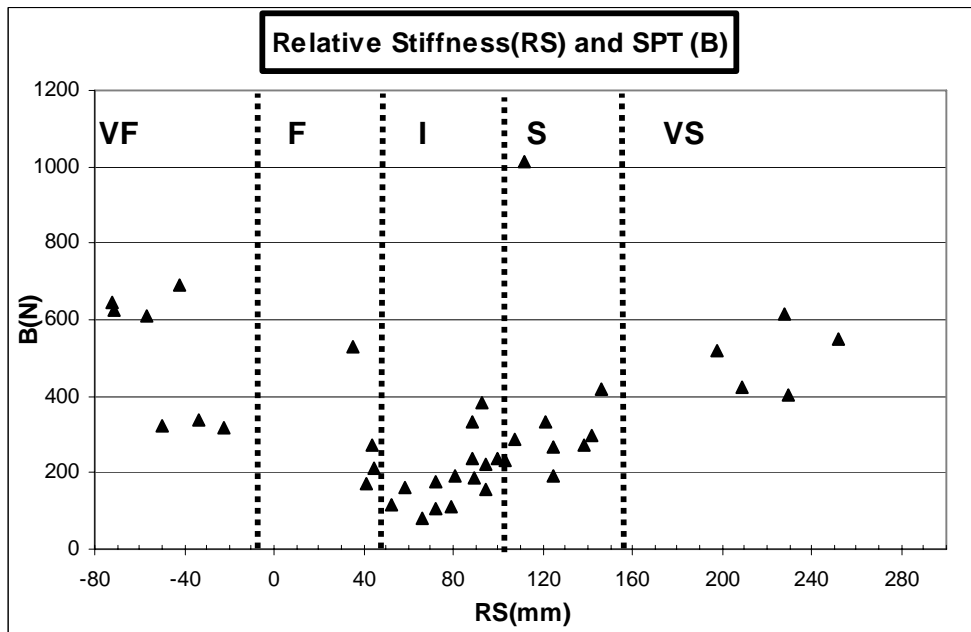

Figure A.10 Graph between relative stiffness (RS) and Tapered Probe (B)

❖ Some correlation, positive

❖ Very flexible geomembranes show moderate puncture resistance (Composite omitted)

APPENDIX -A (Continued)

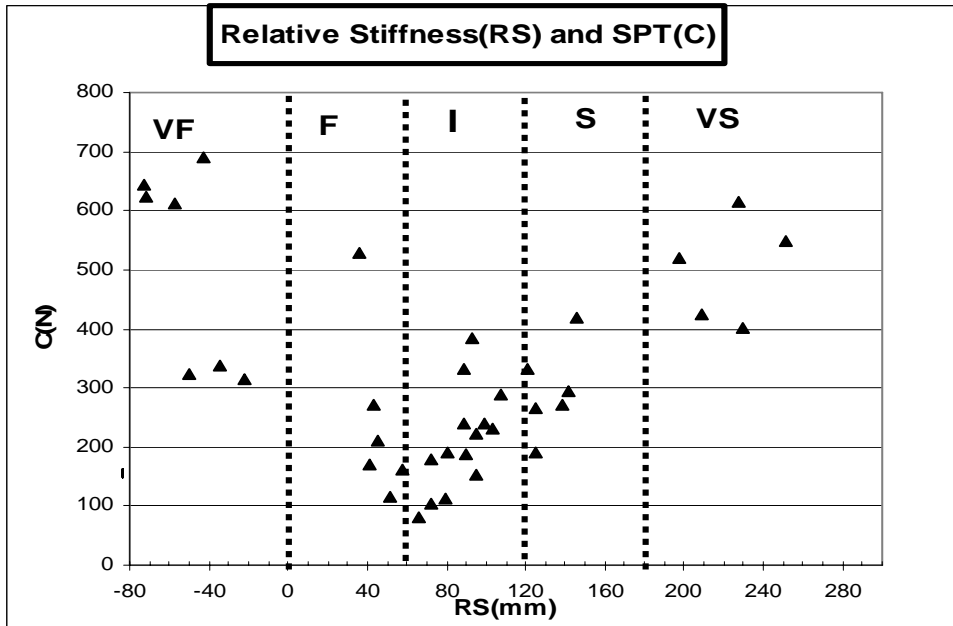

Figure A.11 Graph between relative stiffness (RS) and Tapered Probe (B)

- ❖ Little correlation
- ❖ Very flexible geomembrane show high puncture resistance.
(Composite omitted)

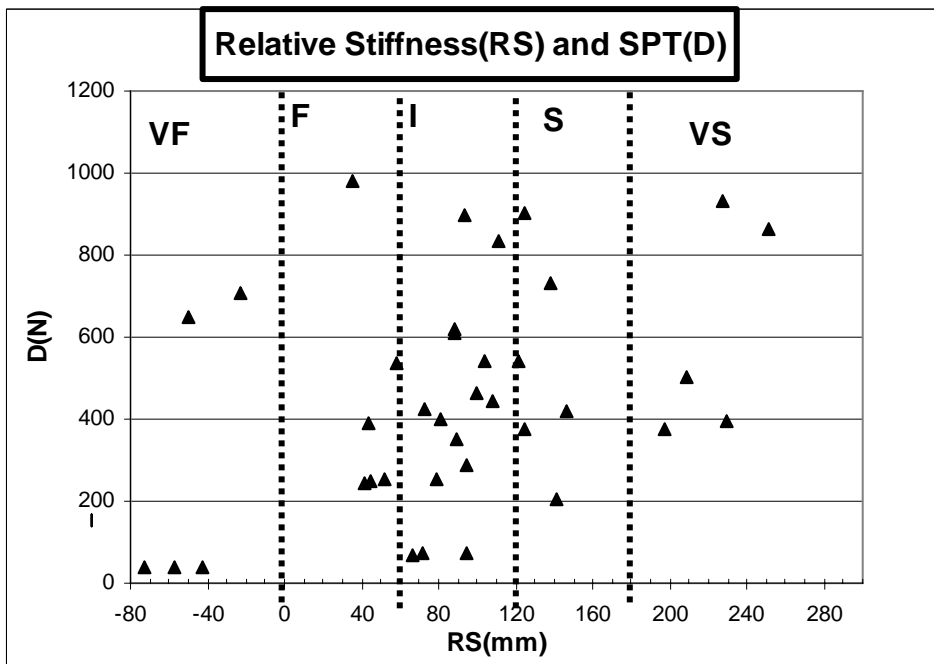

Figure A.12 Graph between relative stiffness (RS) and Tapered Probe (B)

- ❖ Little or no relation
- ❖ Very flexible geomembranes showing low puncture resistance. (Composite omitted)

APPENDIX –A (Continued)

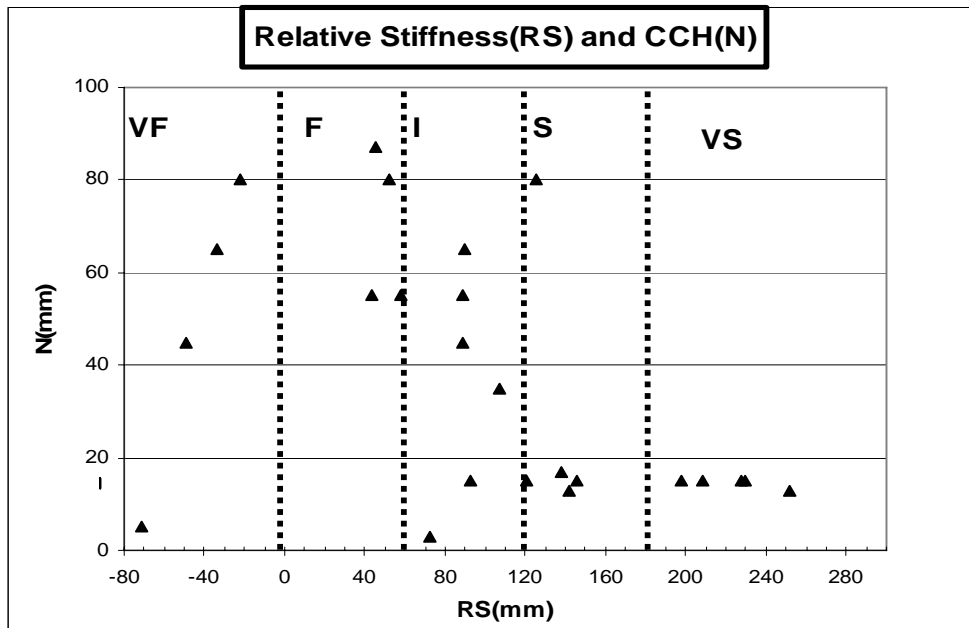

Figure A.13 Graph between relative stiffness (RS) and Tapered Probe (B)

- ❖ Some correlation, negative
- ❖ All stiff and very stiff geomembrane have critical cone height less than 20 mm (Composite omitted)

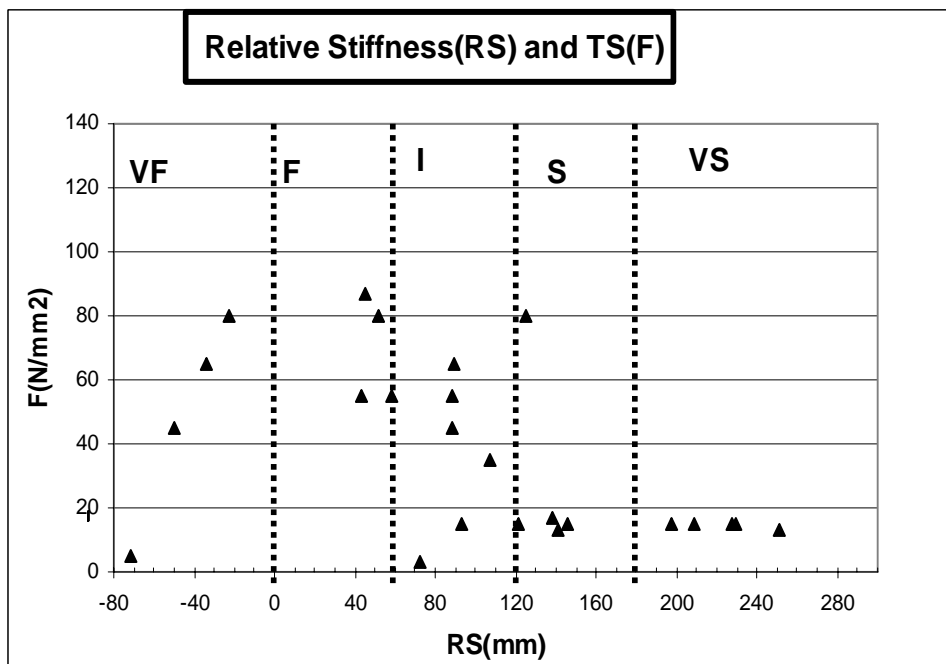

Figure A.14 Graph between relative stiffness (RS) and Tapered Probe (B)

- ❖ Slight correlation, positive. (Composite omitted)

APPENDIX -A (Continued)

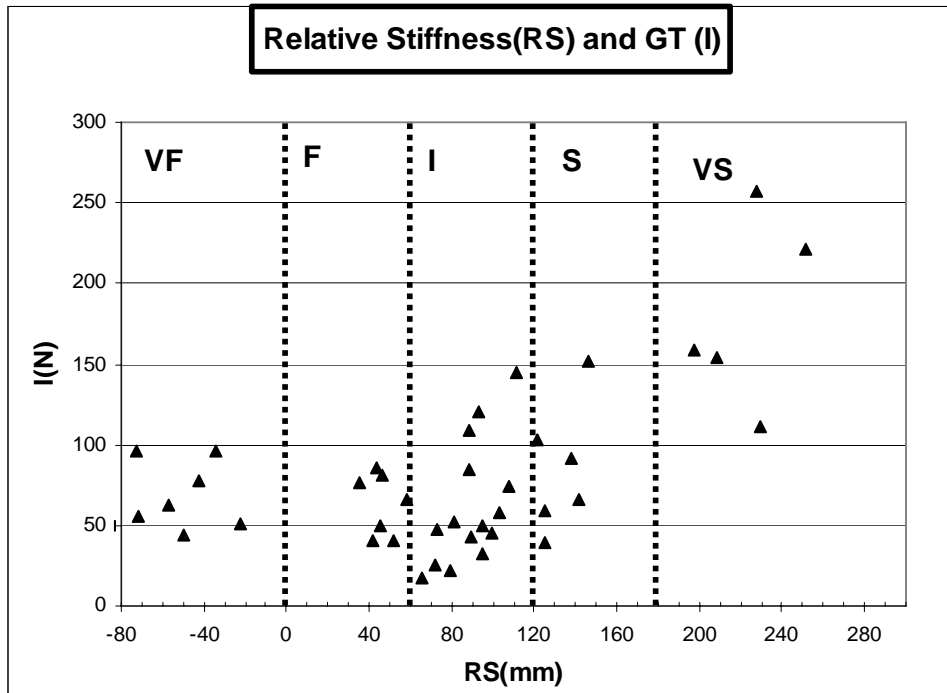
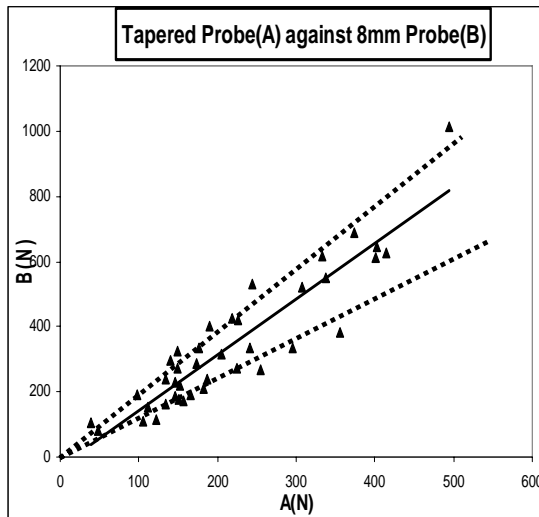

Figure A.15 **Graph between relative stiffness (RS) and Tapered Probe (B)**

❖ Some correlation, positive. (Composite omitted)

APPENDIX –A (Continued)



- ❖ Significant correlation, semi crystalline geomembrane in a fairly narrow band
- ❖ Some grouping within the band, a very stiff geomembranes favoured by 8mm test, VLDPE and FPAs by tapered probe.
- ❖ Reinforced geomembranes within or above the band
- ❖ Very flexible geomembranes within the same band
- ❖ Composite within the same band

Figure A.16 Graph between Tapered Probe and 8 mm Probe.

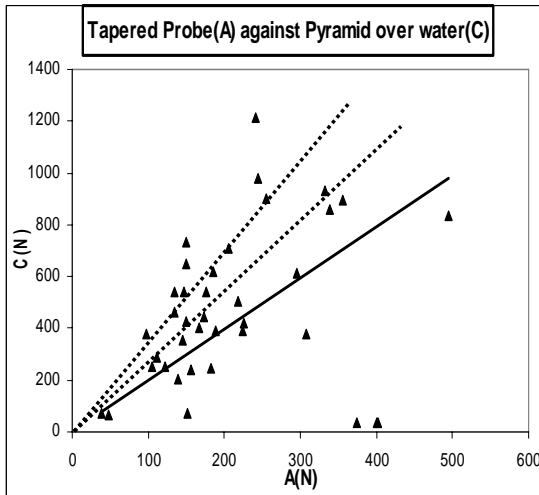

- ❖ Slight correlation, semi crystalline geomembrane in a fairly wide band
- ❖ Little grouping within the band
- ❖ Reinforced geomembranes outside the band
- ❖ Very flexible geomembranes outside the band, favoured by pyramid test (PVC just in the band)
- ❖ Composites show very low resistance to pyramid puncture, high to tapered probe.

Figure A.17 Graph between tapered probe and pyramid over water

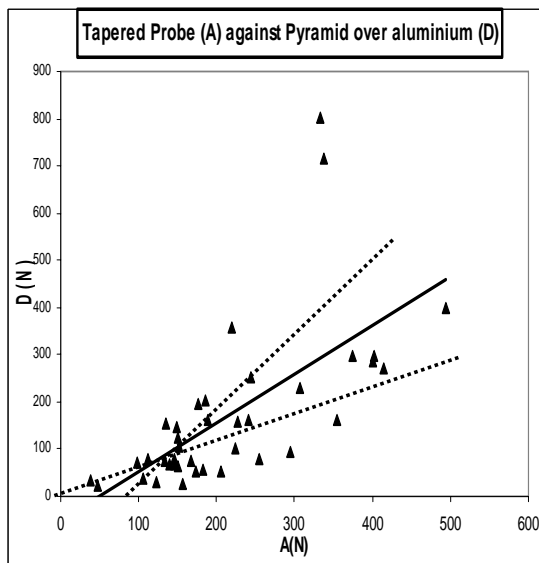

- ❖ Little correlation
- ❖ Composites show moderate resistance to pyramid test, high to tapered probe

Figure A.18 Graph Between tapered probe and pyramid over aluminium

APPENDIX –A (Continued)

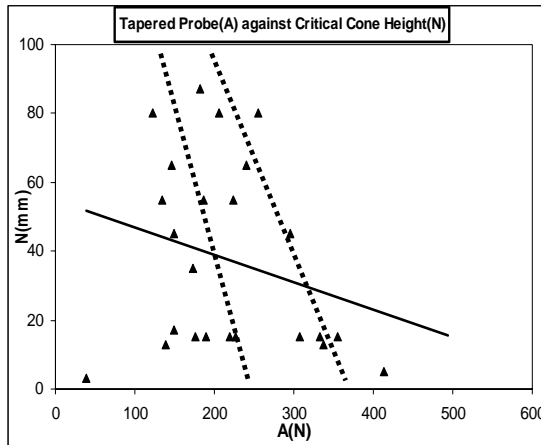

- ❖ *No apparent correlation*
- ❖ *Some negative relation*

Figure A.19 Graph between tapered probe and critical cone height

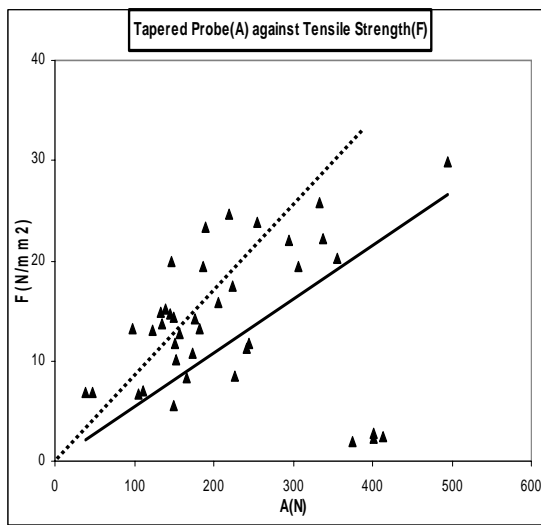

- ❖ *Significant correlation, all semi crystalline geomembrane in a band*
- ❖ *Slight grouping within the band, very stiff geomembrane favoured by tensile test,*
- ❖ *VLDPE and FPA favoured by CCH*
- ❖ *Reinforced geomembrane favoured by puncture test*
- ❖ *Very flexible geomembranes slightly favoured by puncture test*
- ❖ *Composites show high puncture resistance, very low tensile strength*

Figure A.20 Graph between tapered probe and tensile strength

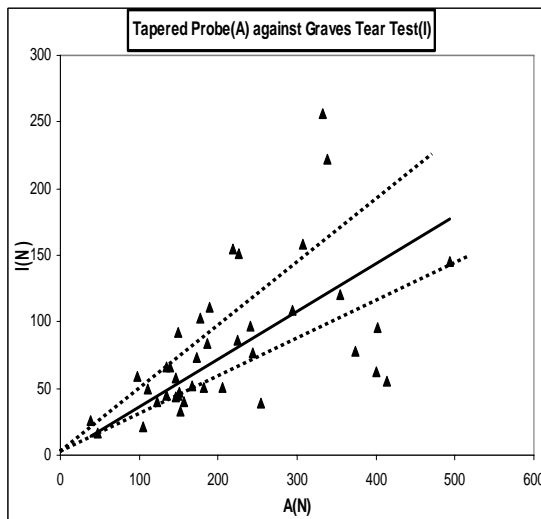

- ❖ *Significant correlation, on within the grouping*
- ❖ *Puncture test favours reinforced, composite and flexible material*
- ❖ *Tear test favours stiff geomembranes*

Figure A.21 Graph between tapered probe and graves tear tests

APPENDIX –A (Continued)

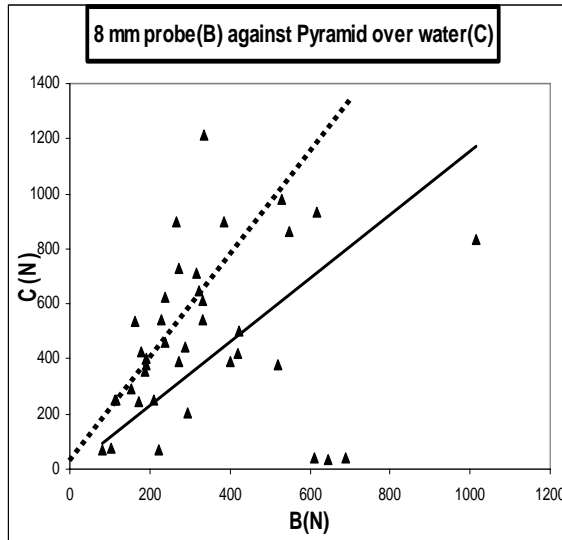

- ❖ Slight correlation, most semicrystalline geomembranes in a fairly wide band
- ❖ Little grouping within the band, though VLDP tends to be favoured by the pyramid test
- ❖ Reinforced geomembranes outside the band, favoured by the 8 mm cylinder test.
- ❖ Very flexible geomembranes outside the band or near its edge, favoured by pyramid test.
- ❖ Composite show very low resistance to pyramid puncture, high to 8 mm cylinder.

Figure A.22 Graph between 8 mm probe and pyramid over water

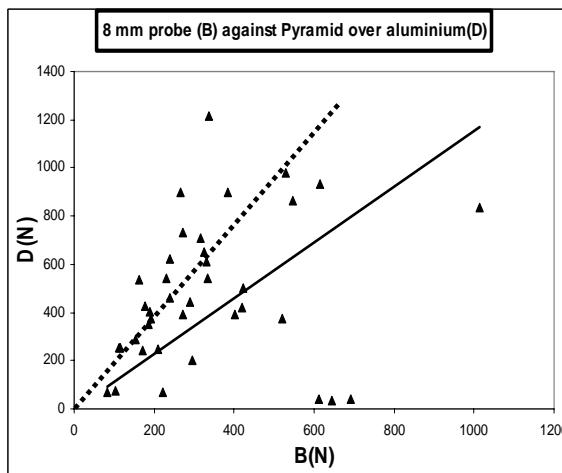

- ❖ Slightly correlation, nearly all materials in a wide band
- ❖ Little grouping within a band
- ❖ One reinforced geomembrane outside the band, favoured by 8 mm cylinder test.
- ❖ Composites show moderate resistance in both tests

Figure A.23 Graph between 8 mm probe and pyramid over aluminium

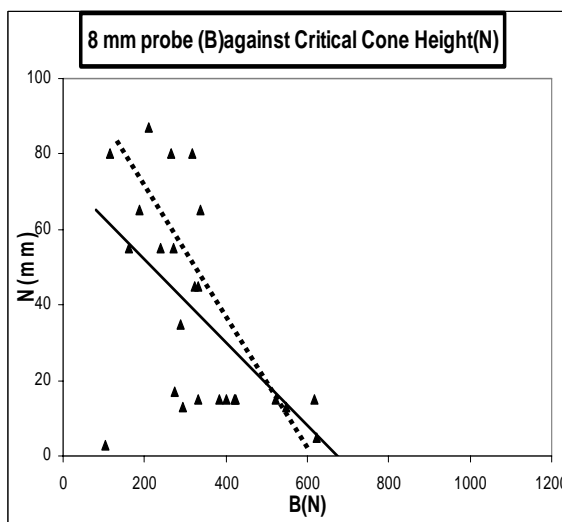

- ❖ Slightly negative correlation.
- ❖ Materials with 8 mm cylinder puncture resistance over 350 N all show critical cone height below 20 mm (composite omitted)

Figure A.24 Graph between 8 mm probe and critical cone height

APPENDIX –A (Continued)

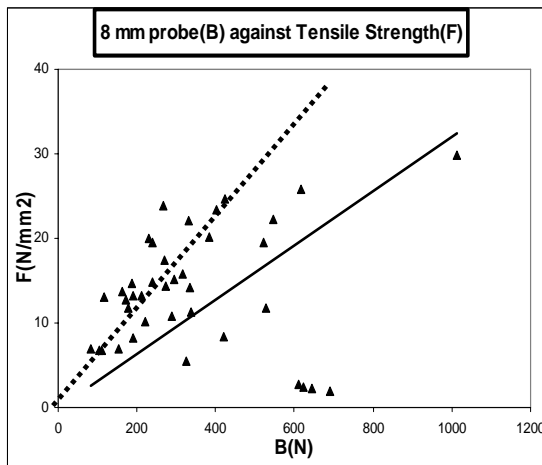

- ❖ Significant correlation, all semi-crystalline geomembranes in a fairly narrow band.
- ❖ Little grouping within the band
- ❖ Reinforced geomembranes outside the band, favoured by puncture test.
- ❖ Composites show high puncture resistance, very low tensile strength

Figure A.25 Graph between 8 mm probe and tensile strength

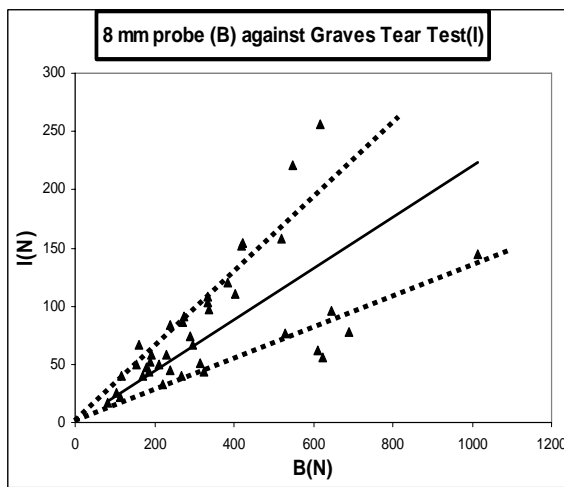

- ❖ Significant correlation, all semicrystalline geomembranes in a fairly narrow band.
- ❖ Little grouping within the band.
- ❖ Reinforced geomembranes outside the band, favoured by puncture test.
- ❖ Very flexible geomembranes just outside the band or near edge, favoured by puncture test.
- ❖ Composites show high puncture resistance, moderate tear resistance

Figure A.26 Graph between 8 mm probe and tear strength

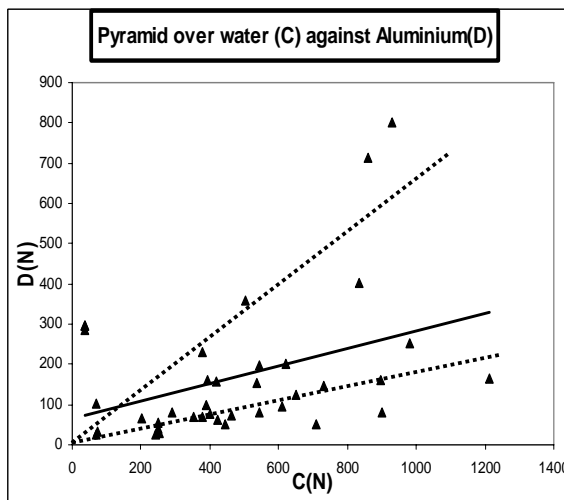

- ❖ Little correlation, semicrystalline geomembranes in a very wide band.
- ❖ Some grouping within the band: HDPE shows better on the test over aluminium.
- ❖ Very Flexible geomembranes favoured by test over water, low resistance in test over aluminium.
- ❖ Composites show high resistance over aluminium, very low over water.

Figure A.27 Graph between pyramid over water and pyramid over aluminium

APPENDIX –A (Continued)

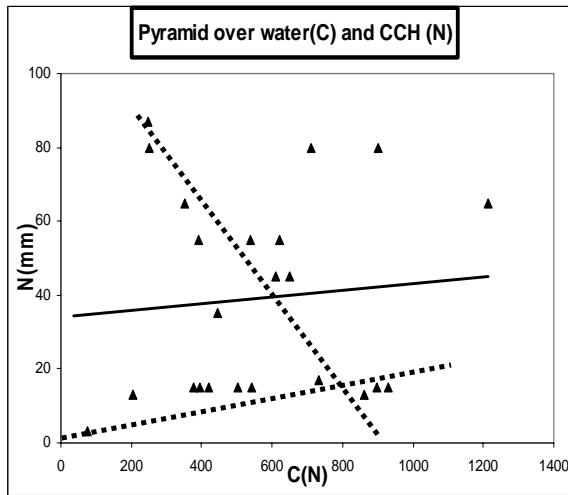

- ❖ *Low, negative relationship or no correlation*
- ❖ *Composite omitted*

Figure A.28 Graph between pyramid over water and critical cone height

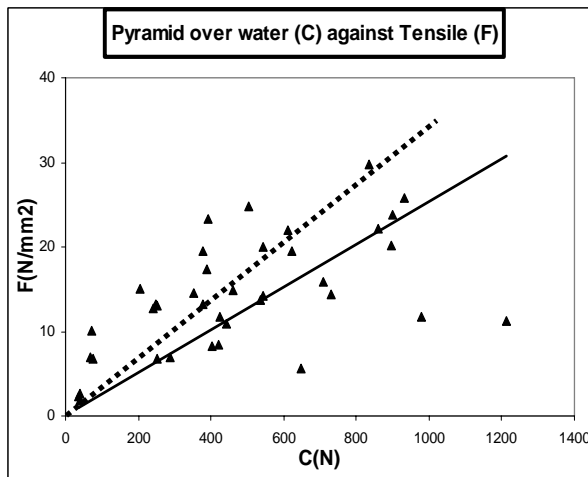

- ❖ *Some correlation, all semicrystalline geomembranes in a wide range*
- ❖ *Notable grouping within the band.*
- ❖ *VLDPE and some LDPEs (Intermediate relative stiffness category) slightly favoured by pyramid puncture test.*
- ❖ *Very stiff geomembranes, like HDPEs, tend to be favoured by tensile test.*
- ❖ *FPAs, (which are flexible geomembranes) also favoured by tensile test; results near HDPEs.*
- ❖ *Very flexible geomembranes favoured by pyramid puncture test.*

Figure A.29 Graph between pyramid over water and tensile strength

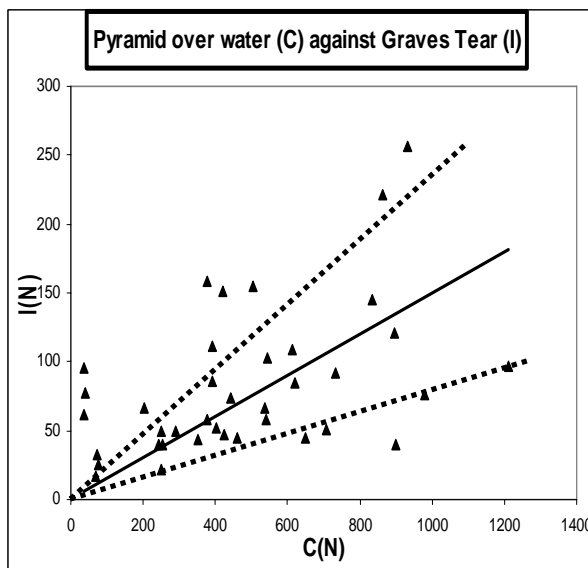

- ❖ *Some correlation, all semicrystalline geomembranes in a fairly band*
- ❖ *Notable grouping within the band, apparently grouped by relative stiffness*
- ❖ *VLDPE and some LDPEs (Intermediate relative stiffness category) slightly favoured by pyramid puncture test.*
- ❖ *Very stiff geomembranes, like HDPEs, tend to be favoured by tear test.*
- ❖ *FPAs, (which are flexible geomembranes) also favoured by tear test; results near HDPEs.*
- ❖ *Very flexible geomembranes favoured by pyramid puncture test.*

Figure A.30 Graph between pyramid over water and tear strength

APPENDIX –A (Continued)

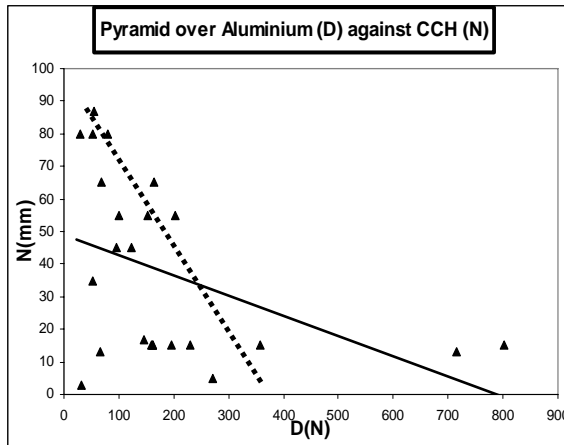

- ❖ Slight negative correlation.
- ❖ Material with pyramid over aluminium puncture resistance over 250 N all show critical cone height 20 mm (Composite omitted)

Figure A.31 Graph between pyramid over aluminium and critical cone height

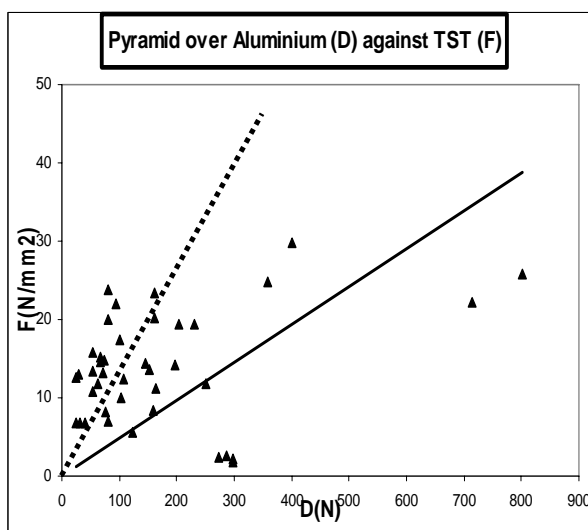

- ❖ Some correlations, but the composites in a wide band.
- ❖ Some grouping within the band; apparently correlated with relative stiffness;
- ❖ Very stiff geomembranes, like HDPEs, tend to be favoured by the puncture test.
- ❖ FPAs, (which are flexible geomembranes) favoured by the puncture test.
- ❖ Very flexible geomembranes lie within the band but showing no correlation.

Figure A.32 Graph between pyramid over aluminium and tensile strength.

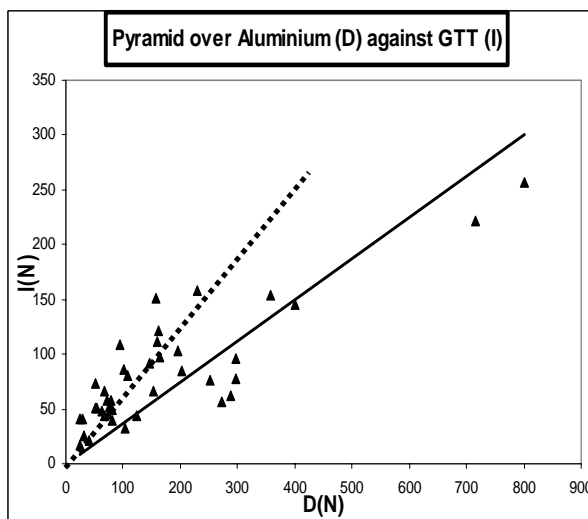

- ❖ Significant correlation, all but some composites within a fairly narrow band. Little grouping among semicrystalline geomembranes within band.
- ❖ Reinforced geomembranes near edge of the band, favoured by the puncture test.
- ❖ Very flexible geomembranes within the band, showing no correlation.
- ❖ Composites slightly favoured by the puncture test.

Figure A.33 Graph between pyramid over aluminium and tear strength

APPENDIX –A (Continued)

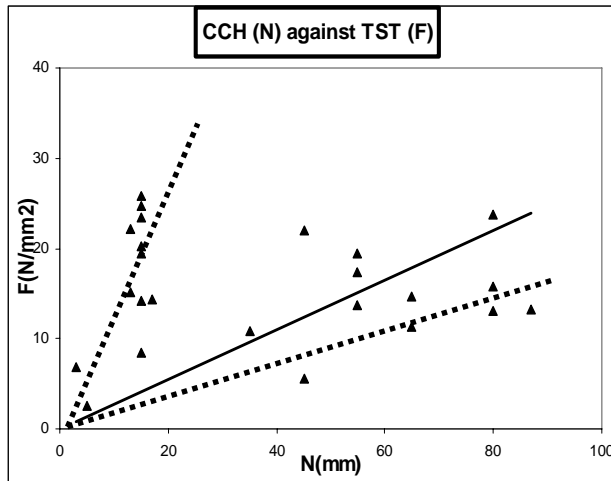

- ❖ Little or no correlation
- ❖ Materials with tensile strength over 200 N all show critical cone height below 20 mm (composites omitted)

Figure A.34 Graph between critical cone height and tensile strength

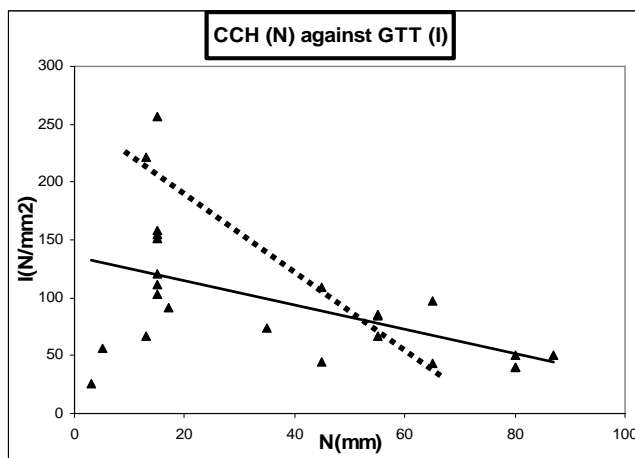

- ❖ Slight negative correlation.
- ❖ Materials with tear resistance over 110 N all show critical cone height below 20 mm. (composite omitted)

Figure A.35 Graph between critical cone height and tear strength

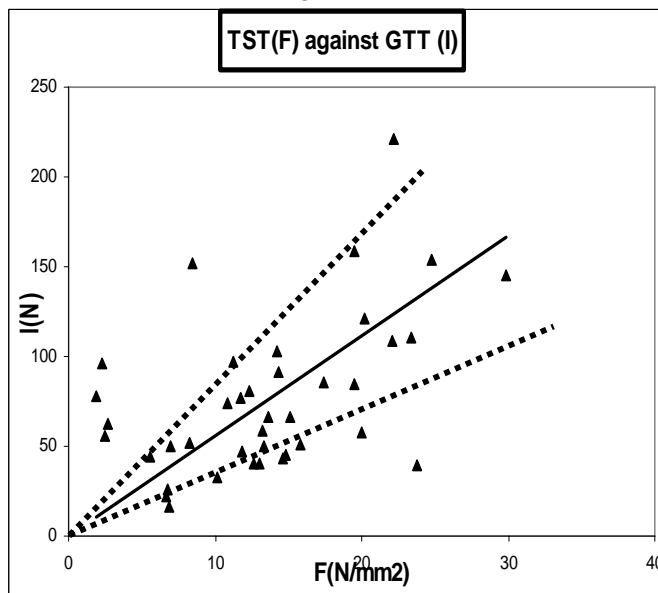
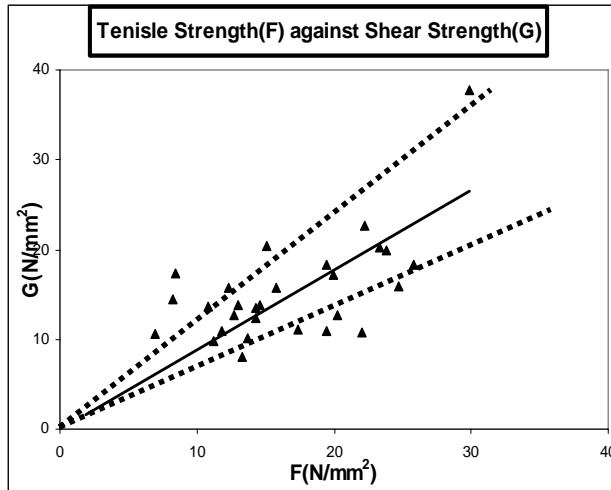

Figure A.36 Graph between tensile strength and tear strength

- ❖ Significant correlation, all but composites in a fairly narrow band.
- ❖ Some grouping within the band, apparently correlated with relative stiffness. Very stiff geomembranes like HDPEs, tend to be favoured by the tear test
- ❖ Intermediate and flexible geomembranes tend to be favoured by the tensile test.
- ❖ Very flexible geomembranes within the band, with the flexible ones.
- ❖ Reinforced geomembranes near edge of band, favoured by the tear test.
- ❖ Composites show moderate tear resistance and low

APPENDIX –A (Continued)

Seam Strength variables



- ❖ Significant correlations.
- ❖ Thicker materials are the outlier of the group.

Figure A.37 Graph between tensile strength and seam shear strength

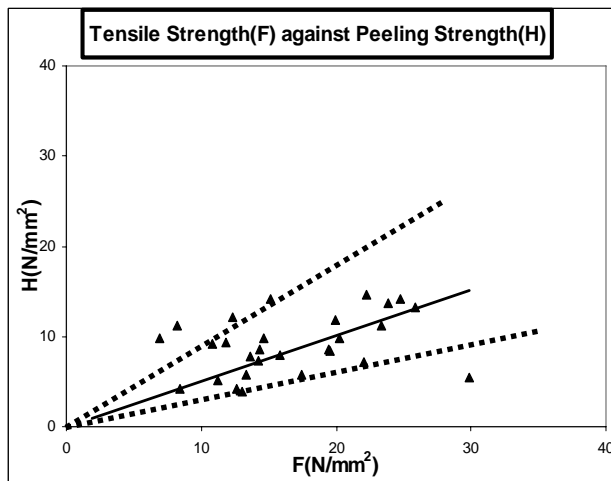

- ❖ Significant correlations.
- ❖ Thicker materials are the outlier of the linear regression band.
- ❖ Composite materials are hardly to seam.

Figure A.38 Graph between tensile strength and seam peeling strength

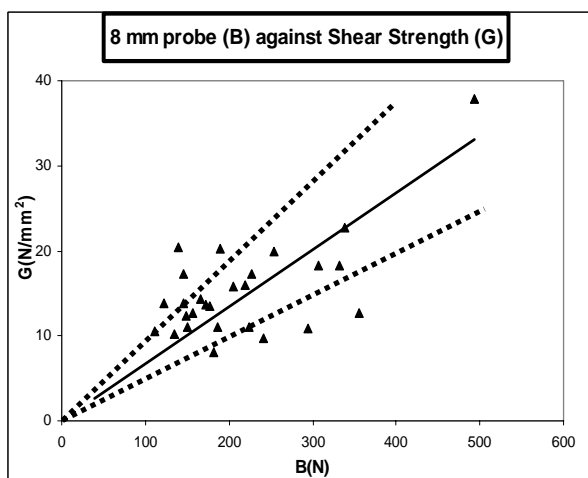

- ❖ Significant correlations.
- ❖ High puncture resistance materials have less shear strength value in other word less seam strength.
- ❖ Also high puncture values materials are out of the linear range band.
- ❖ Composite materials are hardly to seam.

Figure A.39 Graph between 8 mm probe and seam shear strength

APPENDIX –A (Continued)

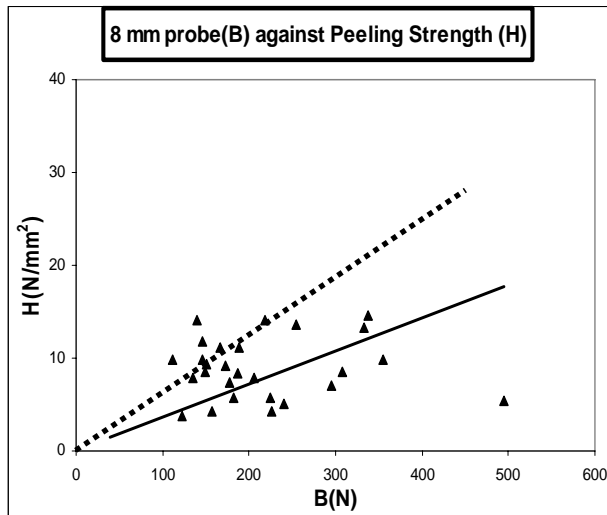

- ❖ *Medium correlations.*
- ❖ *High puncture resistance materials have less peeling strength value in other word less seam strength.*
- ❖ *Also high puncture values materials are out of the linear range band.*
- ❖ *Composite materials are hardly to seam and those are outside the grouping rang .*

Figure A.40 Graph between 8 mm probe and seam peeling strength

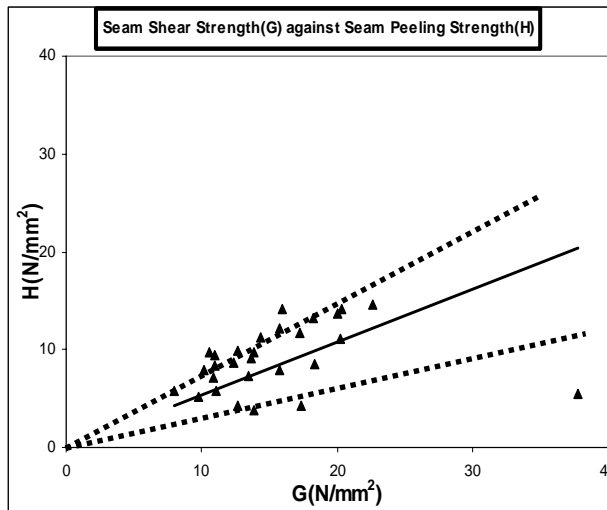

- ❖ *Medium correlations.*
- ❖ *High puncture resistance materials have less peeling strength value in other word less seam strength.*
- ❖ *Also high puncture values materials are out of the linear range band.*
- ❖ *Composite materials are hardly to seam and those are outside the grouping range .*

Figure A.41 Graph between seam shear strength and seam peeling strength

APPENDIX –A (Continued)

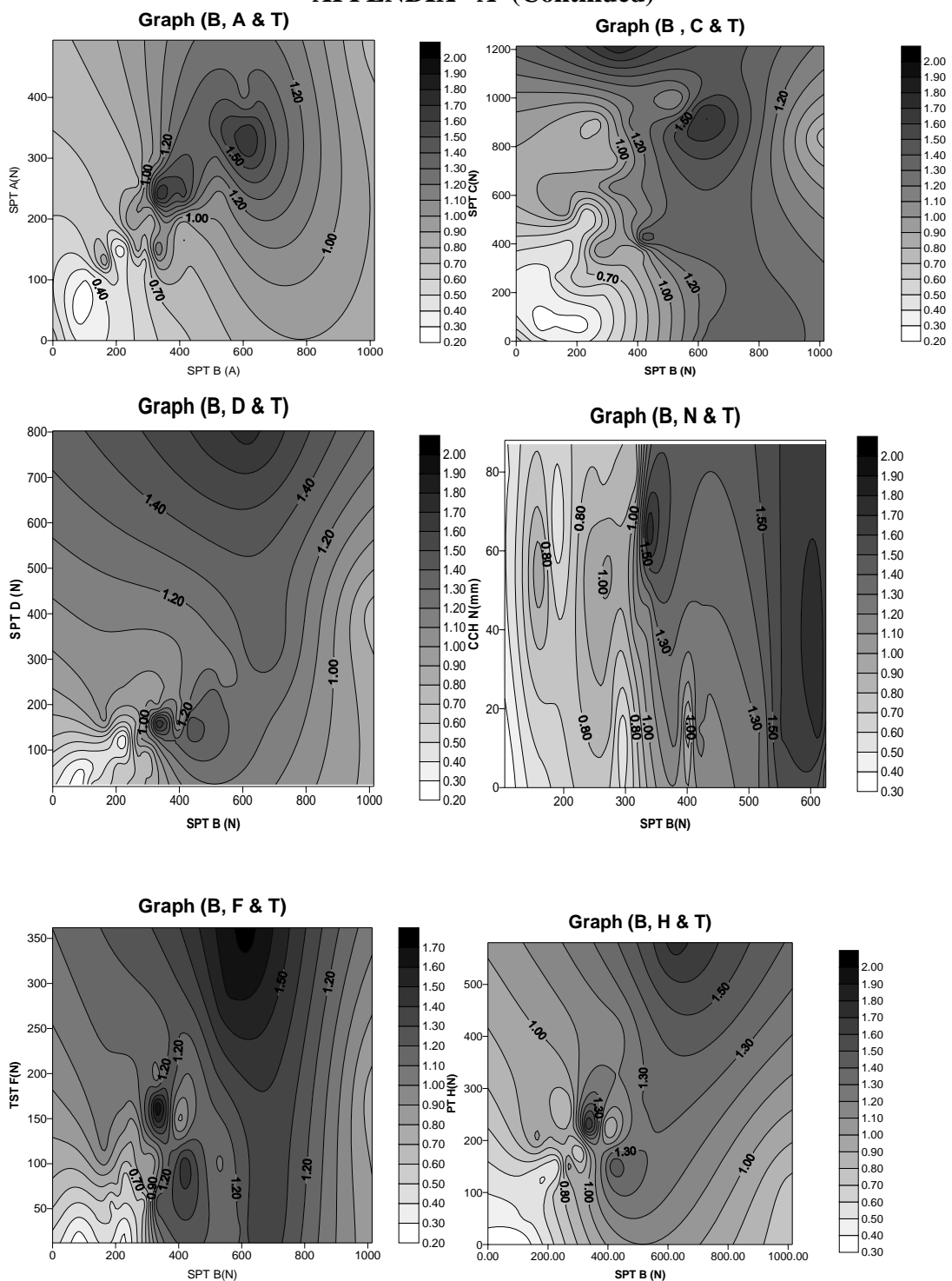
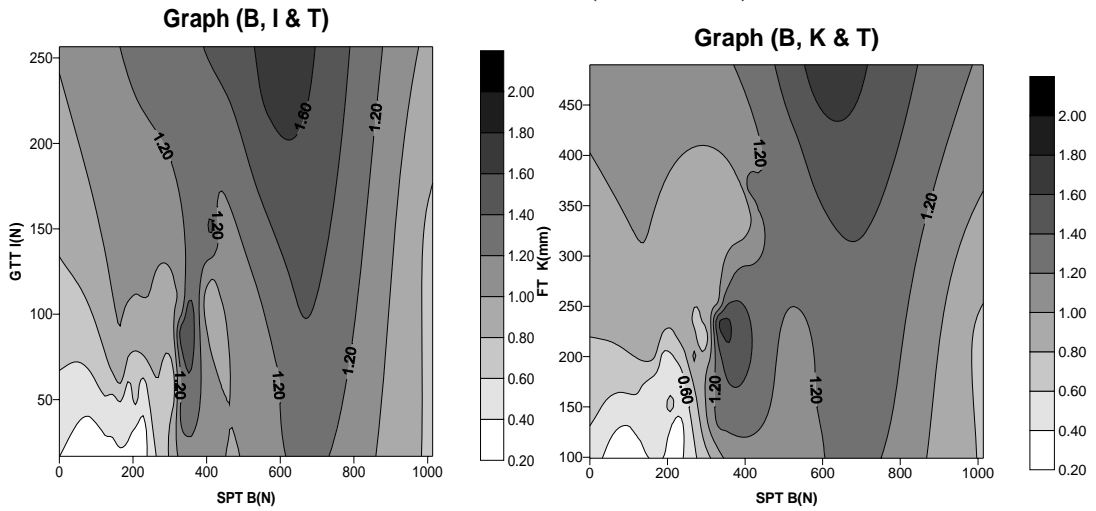

Figure A.42 Triple diagrams between different variables with the slow puncture test (B) as dependent variable

APPENDIX –A (Continued)



Continued Figure A.42 Triple diagrams between different variables with the slow puncture test (B) as dependent variable

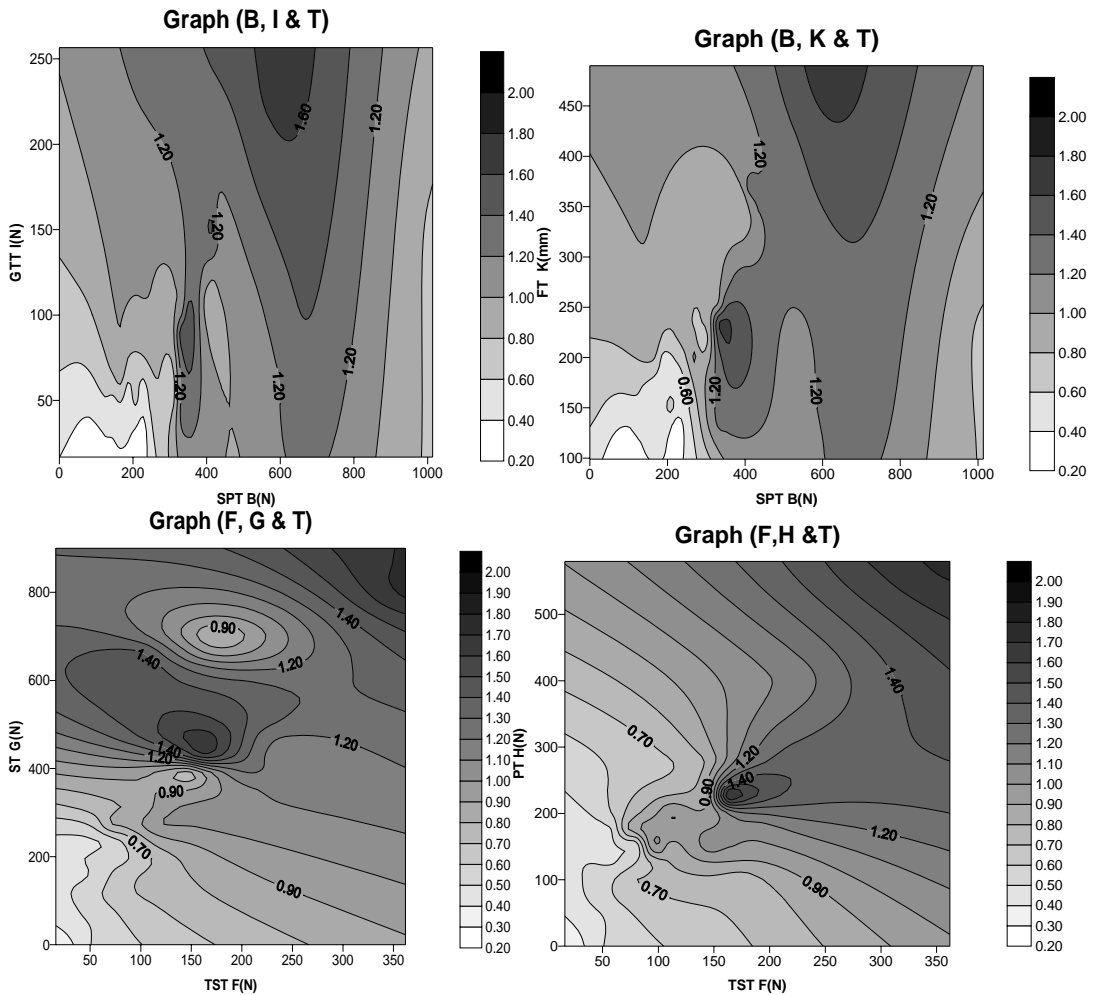
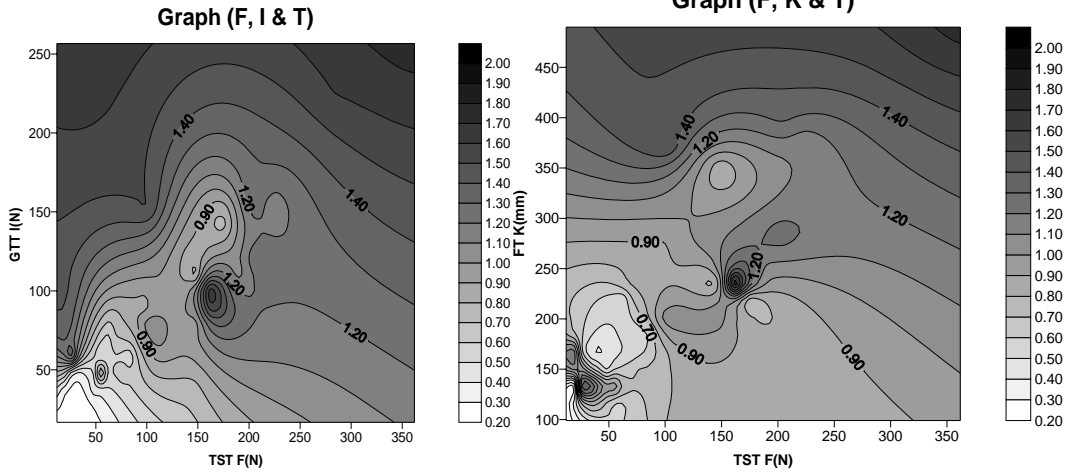

Figure A.43 Triple diagram between different variables with tensile strength (F) as dependent variable.

APPENDIX –A (Continued)



Continued Figure A.43 Triple diagram between different variables with tensile strength (F) as dependent variable.

CURRICULUM VITAE

Muhammad RIAZ was born in 1969 in a city named Bahawalnagar that is located in the Southern part of the Punjab province in Pakistan. After the completion of his primary, secondary and higher secondary education in 1986, from his native town, he got admission in Civil Engineering Department, University of Engineering and Technology (UET), Lahore, Pakistan in 1988. He completed his graduation in 1993 with honours (B.Sc Hons.) and was awarded a distinction certificates. In 1993, he started M.Sc (Engineering) and also worked part time as a Site Engineer for one of the well reputed consulting firm of EME Co-operative Housing Project in Lahore, Punjab (Pakistan). Just after one year, he worked for STFA, a Turkish construction company in Lahore on Lahore Bypass Project as a Construction Engineer. After completing postgraduation in 1996, he joined Punjab Irrigation Department, Pakistan as Assistant Director (Research) and worked for six years. Two research papers had been published during his postgraduation research work. Same year, he was deputed to Fordwah Eastern Sadiqia South (FESS) Irrigation and Drainage Project that was funded by World Bank, where he got training on testing of Geosynthetics in the most modern and a well equipped laboratory of South Asia. He is pioneer to be the first Engineer in Pakistan in the field of Geosynthetics, its testing and quality control. Meanwhile in 2001, he was awarded the Cultural Exchange Scholarship that is a bilateral agreement between Pakistan and Turkey and offered by Turkish Government through Ministry of Education Pakistan. In 2001, he started Doctorate Programme in Hydraulics Engineering and Water Resources, Hydraulics Department of Civil Engineering Faculty in Istanbul Technical University (ITU), Ayazağa Campus, Istanbul. In 2003, he worked as a coordinator for 1st International Advance Course on Data Analysis Techniques on part time basis under the umbrella of Water Engineering Research Development Center (WERDEC), that is a sister organization of Water Foundation Turkey. In this regards, three courses have been organized and he was awarded a letter of appreciation by Water Foundation Turkey (Su Vakfi). He also presented a research paper in the 2nd European Water Resources Association (EWRA) symposium in 2004, held in İzmir Turkey on “Water Resources Management; Risks and Challenges for the 21st Century”. He has a proficient knowledge of English, urdu and also has good command in Turkish language.