

**T.C**  
**ISTANBUL AYDIN UNIVERSITY**  
**INSTITUTE OF GRADUATE STUDIES**



**CONTROLLING ENERGY STORAGE SYSTEM BY USING A FUZZY  
LOGIC CONTROLLER AND ANALYSIS THE EFFECTS OF ADDING A  
SUPERCAPACITOR FOR AN ELECTRICAL VEHICLE**

**MASTER'S THESIS**

**Hajar SRAHNA**

**Department of Electrical & Electronic Engineering**  
**Electrical and Electronics Engineering Program**

**JULY, 2022**



**T.C**  
**ISTANBUL AYDIN UNIVERSITY**  
**INSTITUTE OF GRADUATE STUDIES**



**CONTROLLING ENERGY STORAGE SYSTEM BY USING A FUZZY  
LOGIC CONTROLLER AND ANALYSIS THE EFFECTS OF ADDING A  
SUPERCAPACITOR FOR AN ELECTRICAL VEHICLE**

**MASTER'S THESIS**

**Hajar SRAHNA**  
**(Y1913.300022)**

**Department of Electrical & Electronic Engineering**  
**Electrical and Electronics Engineering Program**

**Thesis Advisor: Asst. Prof. Eylem Gülce ÇOKER**

**JULY, 2022**

## **DECLARATION**

I hereby declare with respect that the study “CONTROLLING ENERGY STORAGE SYSTEM BY USING A FUZZY LOGIC CONTROLLER AND ANALYSIS THE EFFECTS OF ADDING A SUPERCAPACITOR FOR AN ELECTRICAL VEHICLE”, which I submitted as a Master thesis, is written without any assistance in violation of scientific ethics and traditions in all the processes from the Project phase to the conclusion of the thesis and that the works I have benefited are from those shown in the Bibliography (17/07/2022).

Hajar SRAHNA

## **FOREWORD**

First, I would like to express my perpetual appreciation to ALLAH for giving me the strength to survive and for protecting us from this pandemic, as well as the daring to overcome all difficulties and finish my thesis.

I would like to express my sincere appreciation to my thesis advisor, Dr. Öğr. Üyesi EYLEM GÜLCE ÇOKER, also I would like to express my thanks to the teaching and administrative staff of ISTANBUL AYDIN UNIVERSITY specially the Electrical and Electronic Engineering teacher's. Finally, I want to thank my family for their support, and their unconditional support either moral or financial support, and my friends and every person who gave me any support or advice which help me in my work.

JULY, 2022

Hajar SRAHNA

# **CONTROLLING ENERGY STORAGE SYSTEM BY USING A FUZZY LOGIC CONTROLLER AND ANALYSIS THE EFFECTS OF ADDING A SUPERCAPACITOR FOR AN ELECTRICAL VEHICLE**

## **ABSTRACT**

Intelligent energy storage system was design and presented by using a battery pack connected in parallel with a supercapacitor which is directly connected to the load, the battery is connected to a parallel bi-directional DC/DC converter which has as a main job to regulate the output current of the battery so it can match the supercapacitor current and reduce the output current's ripples. The directly connected supercapacitor used in the intelligent energy storage system to reduce the pressure on the battery pack either in the quick acceleration because it required a huge power for a short period, or in the braking state where the electrical vehicle convert the kinetic rolling energy into electrical energy to charge the storage system, where the motor produce a huge amount of power, so the directly connected supercapacitor capture this energy which prevent high power loading on the battery, which improve the whole performance of the vehicle by increasing the life cycle of the battery pack. The Fuzzy Logic Controller was designed to determine the Duty Cycle (the Duty cycle is calculated based on the desired motor speed or the output motor current), which control the DC/DC converter. The simulation was done on SIMULINK-MATLAB platform.

**Key Words:** Supercapacitor, Parallel staggered DC/DC converter, Fuzzy logic controller, Electrical vehicle.

**BULANIK BİR MANTIK DENETLEYİCİSİ KULLANARAK ENERJİ  
DEPOLAMA SİSTEMİNİ KONTROL ETMEK VE ELEKTRİKLİ BİR ARAÇ  
İÇİN SÜPER KAPASİTÖR EKLEMENİN ETKİLERİNİ ANALİZ ETMEK**

**ÖZET**

Akıllı enerji depolama sistemi, yüke doğrudan bağlı bir süperkapasitör ile paralel bağlı bir pil takımı kullanılarak tasarlanmış ve sunulmuştur, pil, ana görevi pilin çıkış akımını düzenlemek, böylece süper kapasitör akımına uyum sağlamak ve çıkış akımının dalgalanmalarını azaltmak olan paralel çift yönlü bir DC/DC dönüştürücüye bağlıdır. Akıllı enerji depolama sisteminde, pil takımı üzerindeki basıncı azaltmak için kullanılan doğrudan bağlı süper kapasitör, kısa bir süre için büyük bir güç gerektirir, bu nedenle elektrikli aracın kinetik yuvarlanma enerjisini şarj etmek için elektrik enerjisine dönüştürdüğü hızlı hızlanma veya frenlemede Motorun büyük miktarda güç ürettiği depolama sistemi, bu nedenle, doğrudan bağlı süper kapasitör bu enerjiyi yakalar ve bataryaya yüksek güç yüklenmesini önler, bu da bataryanın ömrünü uzatır ve aracın genel performansını iyileştirir. Bulanık Mantık Denetleyicisi, DC/DC dönüştürücüyü kontrol eden Görev Döngüsünü (Görev döngüsü, istenen motor hızına veya çıkış motor akımına göre hesaplanır) belirlemek için tasarlanmıştır. Simülasyon SIMULINK-MATLAB platformunda yapılmıştır.

**Anahtar Kelimeler:** Süper kapasitör, Paralel kademeli DC/DC dönüştürücü, Bulanık mantık kontrolörü, Elektrikli araç.

## TABLE OF CONTENTS

<b>DECLARATION</b> .....	iii
<b>FOREWORD</b> .....	iv
<b>ABSTRACT</b> .....	v
<b>ÖZET</b> .....	vi
<b>TABLE OF CONTENTS</b> .....	v
<b>ABBREVIATIONS</b> .....	vii
<b>LIST OF TABLES</b> .....	viii
<b>LIST OF FIGURES</b> .....	ix
<b>I. INTRODUCTION</b> .....	<b>1</b>
A. Introduction .....	1
B. Tools and Explanation.....	2
C. Research Objectives .....	2
<b>II. LITERATURE REVIEW</b> .....	<b>3</b>
A. Introduction .....	3
B. Li-ion Battery .....	3
C. Supercapacitor .....	4
D. Self-Discharge .....	6
E. Buck-Boost Converter .....	7
F. Boost Converter.....	8
G. Buck Converter .....	10
H. Fuzzy Logic Controller .....	10
I. Battery and Supercapacitor Combination .....	11

<b>III.</b>	<b>THE MAIN INTELLIGENT ENERGY STORAGE SYSTEM.....</b>	<b>12</b>
A.	Source of Energy .....	13
1.	Lithium-ion Battery .....	13
2.	Supercapacitor .....	14
B.	Bi-directional DC / DC Converter .....	14
1.	Boost Converter.....	15
2.	Buck Converter .....	17
C.	Parallel DC/DC Bi-directional Converter .....	19
D.	Pulse Width Modulation.....	19
E.	The Fuzzy Logic Controller .....	21
F.	Electrical DC Motors .....	23
1.	Dc Brushless Motor (BLDC) .....	24
2.	Brushed Dc Motor .....	25
3.	Switched Reluctance Motor .....	26
<b>IV.</b>	<b>METHODOLOGY.....</b>	<b>27</b>
A.	Purpose and Importance .....	27
1.	Battery Pack .....	28
2.	Supercapacitor .....	28
3.	Parallel Bi-directional dc/dc Converter .....	29
4.	The Fuzzy Logic Controller Design.....	30
<b>V.</b>	<b>RESULTS AND DISCUSSION.....</b>	<b>34</b>
A.	Introduction .....	34
B.	When The Vehicle is Within the Braking State (Charging).....	34
1.	Scenario 1 .....	35
2.	Scenario 2 .....	37
C.	When the Vehicle is Running Normally (Discharging) .....	38
1.	Scenario 1 .....	39
2.	Scenario 2 .....	41
D.	Analysis the Impact of the Supercapacitor on the System .....	42
<b>VI.</b>	<b>CONCLUSION.....</b>	<b>44</b>
<b>VII.</b>	<b>REFERENCES.....</b>	<b>45</b>



## **ABBREVIATIONS**

**IESS** : Intelligent energy storage system

**EV** : Electrical Vehicle

**CV** : Conventional vehicles

**SOC** : State of Charge

**FLC** : Fuzzy Logic Controller

**D** : Duty cycle

**DC/DC** : Direct Current to Direct Current converter

**CC** : Constant-current

**CCCV** : Constant Current - Constant Voltage

## LIST OF TABLES

Table 1 The advantages and disadvantages of supercapacitor (Şahin, et al., 2021). .....	4
Table 2 DC/DC converter conduction mode table.....	30
Table 3 Fuzzy rules table when SOC-b is high.....	33
Table 4: Fuzzy rules table when SOC-b is low.....	33
Table 5 Results table of the first scenario. ....	42
Table 6 Results table of the second scenario. ....	42

## LIST OF FIGURES

Figure 1 Roadmap of batteries technology from 2013 to 2030 (Zhuang, et al., 2014).....	4
Figure 2 The supercapacitor module that was presented in this paper (Şahin, et al., 2021). .....	5
Figure 3 Comparison between CC and CCCV with 3.3F supercapacitors (Dinglasan-Fenol, et al.,2016).....	6
Figure 4 Comparison between CC and CCCV with 4.7F supercapacitors (Dinglasan-Fenol, et al.,2016).....	7
Figure 5 Circuit configuration of proposed DC-DC buck boost converter (Soheli et al., 2018). .....	8
Figure 6 Circuit Diagram for the Boost Converter (Boujelben et al., 2017). .....	9
Figure 7 DC-DC buck converter circuit configuration. ....	10
Figure 8 Intelligent energy storage system structure. ....	12
Figure 9 The equivalent circuit of MATLAB/SIMULINK li-ion battery (Mathworks, 2022). .....	13
Figure 10 The energy flow in the bi-directional DC/DC converter. ....	15
Figure 11 Buck/Boost bi-directional DC-DC converter (Ravi, et al., 2018). ....	15
Figure 12 Switching sequence of the boost converter (Tutkun, 2021). ....	16
Figure 13 Switching sequence of the buck converter (Tutkun, 2021). ....	18
Figure 14 Parallel staggered DC / DC converter. ....	19
Figure 15 Principles of PWM generation (Hamza, et al., 2014).....	20
Figure 16 Wave form of PWM (Hamza, et al., 2014).....	20
Figure 17 PWM signal (Hamza, et al., 2014). ....	20
Figure 24 The inference process of a Mamdani system (Mathworks, 2022).....	21
Figure 25 The fuzzy inference process for a Sugeno system (Mathworks, 2022).....	22
Figure 26 Block diagram of a fuzzy controller with details (Wahid, et al., 2011). ....	22
Figure 18 3D sketch of the DC. Motor (Mepits, 2014).....	24

Figure 19 Basic arrangement of rotor and sensor elements in BLDC motor (Jape, et al., 2017). .....	25
Figure 20 components arrangement of brushed dc motors (Jape, et al., 2017).....	25
Figure 21 The entire system block diagram in MATLAB/SIMULINK platform. ....	27
Figure 22 The used supercapacitor model. ....	29
Figure 23 Parallel bi-directional DC / DC converter. ....	30
Figure 27 The membership function of SOC-B.....	31
Figure 28 The membership function of SOC-C.....	31
Figure 29 The membership function of $I_o$ . ....	31
Figure 30 The membership function of D1.....	32
Figure 31 The membership function of D2.....	32
Figure 32 The load current during charging of the first scenario. ....	35
Figure 33 Changes in current during charging mode of scenario 1 .....	36
Figure 34:Changes in SOC during charging mode of scenario 1.....	36
Figure 35 The load current during charging of the second scenario.....	37
Figure 36 Changes in current during charging mode of scenario 2. ....	38
Figure 37 Changes in SOC during charging mode of scenario 2.....	38
Figure 38 The load current during discharging of the first scenario.....	39
Figure 39 Changes in current during discharging mode in scenario 1.....	40
Figure 40 Changes in SOC during discharging mode of scenario 1. ....	40
Figure 41 The load current during discharging of the second scenario. ....	41
Figure 42 Changes in current during discharging mode of scenario 2. ....	41
Figure 43 Changes in SOC during discharging mode of scenario 2. ....	42
Figure 44 The battery's discharging SOC without supercapacitor.....	43
Figure 45 The battery's charging SOC without supercapacitor. ....	43

# **I. INTRODUCTION**

## **A. Introduction**

For the last century, electrical vehicles (EV) were wildly interesting subject to many scientists and manufacturers due to the increasing of demand on electrical vehicles compared to the conventional vehicles (CV), because it has no carbon emission which makes it environmental friendly transportation way (Hu, et al., 2020), it also reduces the driving cost which makes it more suitable from the economical view, and the working mechanism of the electrical motor produce rotational motion unlike the normal fuel motors which produce linear motion and then to be converted to rotational motion which will lead to a big drop in the motor's efficiency and these is why almost all the electrical vehicles are more efficient in the energy consumption principle.

The most important part in the electrical vehicle is the battery pack which have two main factors to be calculated and/or analyzed in the designing procedure: State of Charge (SOC) and the battery pack capacity. The battery pack capacity is directly linked to the maximum travel distance for one fully charged battery, and the SOC according to many studies that has been published (Gharehpetian, et al., 2017) shows that the SOC percentage within a period has a relationship with the battery pack life cycle, and efficiency. However, the battery has some disadvantage such as low power density and short cycle life which restrict the performance of the electrical vehicle.

The combination between the batteries and supercapacitors can improve the electrical vehicle's performance and extend the battery's lifetime because the batteries are characterized by high energy density, and low self-discharge and supercapacitors are characterized by high-power density, long lifetime, and high number of charge and discharge cycle, therefore we can stablish that by adding a suitable supercapacitor to the electrical vehicle improve the overall vehicle's energy storage system.

## **B. Tools and Explanation**

Energy storage system plays a main role in electrical vehicles, here it's came the idea of the Intelligent energy storage system (IESS), which improve the whole performance of the vehicle, the IESS is a combination of batteries and supercapacitors in one system, main point is to ensure that the pressure will be reduced from the battery during the whole vehicle's trip, which will extend the battery pack lifetime. A DC/DC converter and a fuzzy logic controller were used in the simulation to control the output current of the system. MATLAB /Simulink platform is utilized for testing the proposed topology.

## **C. Research Objectives**

The main goal of this thesis is to reduce the pressure that would be done on the battery pack of an electrical vehicle in any sharply increasing or decreasing in the load current, by adding a supercapacitor the pressure on the battery can be reduces during to whole trip, which increase the life cycle of the battery pack and get a higher efficiency.

## II. LITERATURE REVIEW

### A. Introduction

In this section lecturer review present different parts of the IESS with some of their characteristics and important information to be noted.

### B. Li-ion Battery

In this paper the development of components of li-ion batteries is discussed to have more security and bigger energy density to keep up with the rapid progress specially in the electrical vehicle and hybrid electrical vehicle Considering is the main the battery the source of energy (Zhuang, et al., 2014).

The actual batteries contain in the anode the carbon as materiel, and in the cathode the  $\text{LiNi}_{1-x-y}\text{Co}_x\text{Mn}_y\text{O}_2$ , spinel  $\text{Li}_2\text{MnO}_4$  or olivine  $\text{LiFePO}_4$  as material, which give as a specific energy between 150~180 Wh/kg (Zhuang, et al., 2014).

But according to many development studies that forces us to change the material of the batteries in order to achieve an energy density of 500 Wh/kg, to achieve this, the  $\text{Li}_2\text{MnO}_3$ -LMO2 as a cathode materiel and nano silicon composite as anode material has been studied in China which increase the energy density to 250 Wh/kg. And to enhance the safety much research is going to be focused on the electrolyte salts and flame-retardant electrolyte. Despite of all this development but still have a lot of work to do to improve the performance of electrical vehicle (Zhuang, et al., 2014).

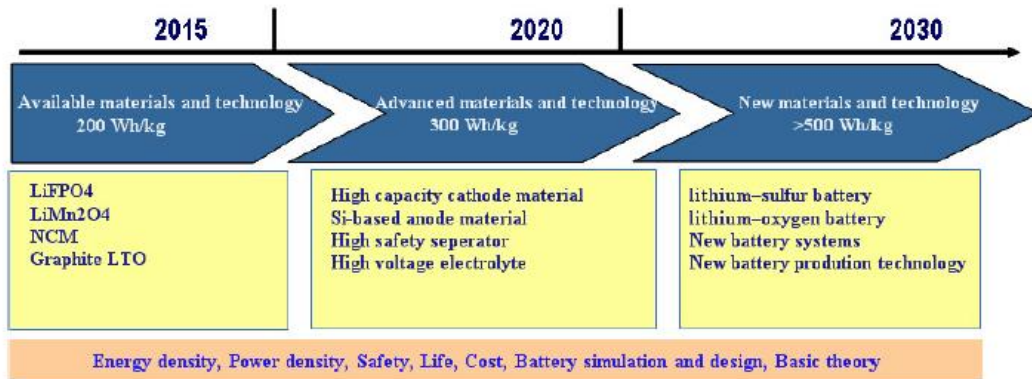

Figure 1 Roadmap of batteries technology from 2013 to 2030 (Zhuang, et al., 2014).

### C. Supercapacitor

In this paper, an electrical circuit model based on the voltage and current equations is proposed as a solution of the supercapacitor parameters problem. First, to propose a new model, the knowledge of the difference between the super capacitor and the others storage energy system and the different models proposed for supercapacitors is important (Şahin, et al., 2021).

Table 1 The advantages and disadvantages of supercapacitor (Şahin, et al., 2021).

Advantage	Disadvantage
high power density	low energy density
Fast charging and discharging	high self-discharge rate
Long lifetime and shelf life	-----
Ecologically secure	-----

Compared to others energy storage system like batteries and Electrolytic capacitor, the supercapacitor has more advantage expect for the energy density.

Various model of supercapacitor has been proposed, firstly, the classical model which is composed of a capacitance, internal resistance, and a parallel resistance to show leakage charge, secondly, the Nelms et a model which is based on Debye polarization cell,

thirdly, it's the conventional model, finally, the successful model, the dynamic model but all those model obligate an intensive test to acquire the SCs parameters which made them not too much used (Şahin, et al., 2021).

There are others model doesn't require the test like, Zubieta model and Faranda model which is a disentangled form of Zubieta model since it use one RC branch instead of three, the zubieta model is not too much used because of the difficulty of parameters determination, contrariwise Faranda model invent a parameters determination based on measurement (Şahin, et al., 2021).

The proposed model is composed of an RC branch to detect the responses of the supercapacitor during the fast charging and discharging, and another RC branch to detect the internal energy distribution, furthermore, the leakage current is neglecting. In the proposed model the parameters identification is done by charging the DLC from zero to rated voltage and during the internal charge redistribution we observe the terminal voltage amid a period of 30 min (Şahin, et al., 2021).

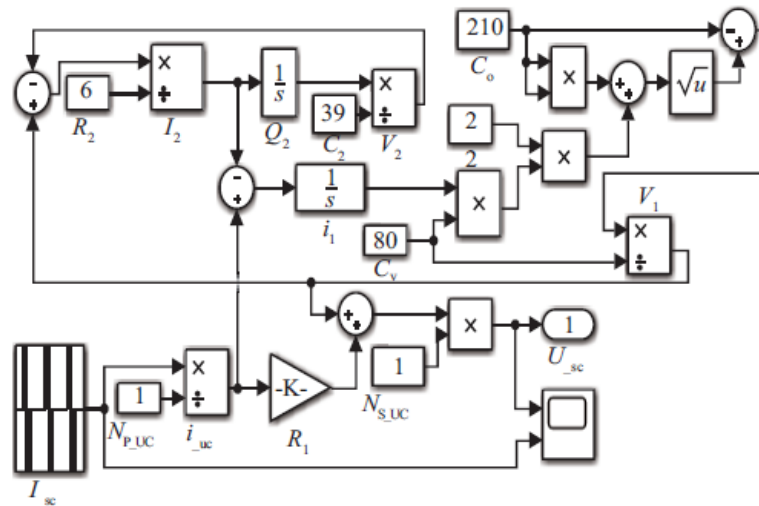

Figure 2 The supercapacitor module that was presented in this paper (Şahin, et al., 2021).

The results obtained in the simulations correspond with the datasheet, which make this model a good choice to be used in the renewable energy applications for example electrical vehicles (Şahin, et al., 2021).

## D. Self-Discharge

In this paper the effect of charging on self-discharge of a supercapacitor is represented, the supercapacitor will be charged in two different methods a constant-current (CC) and Constant Current - Constant Voltage (CCCV) Charging. Two different commercial supercapacitors were used 4.7F and 3.3F capacitance with a rated voltage of 2.5V. The experiment shows that the CCCV is the better than the CC method of charging to reduce the self-discharge current because the CCCV method can keep up a consistent voltage for one or two hour/s after supercapacitors was charge in a steady current which gives us as a result a slow self-discharge. At the same time the CC method still used in case of less power consumption and time in charging (Dinglasan-Fenol, et al.,2016).

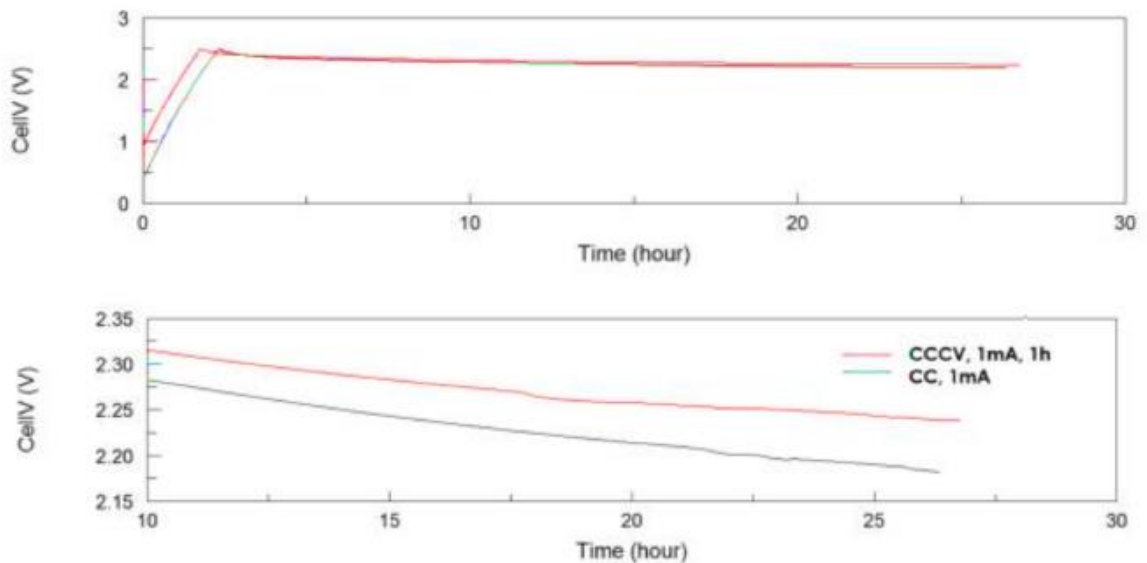

Figure 3 Comparison between CC and CCCV with 3.3F supercapacitors (Dinglasan-Fenol, et al.,2016).

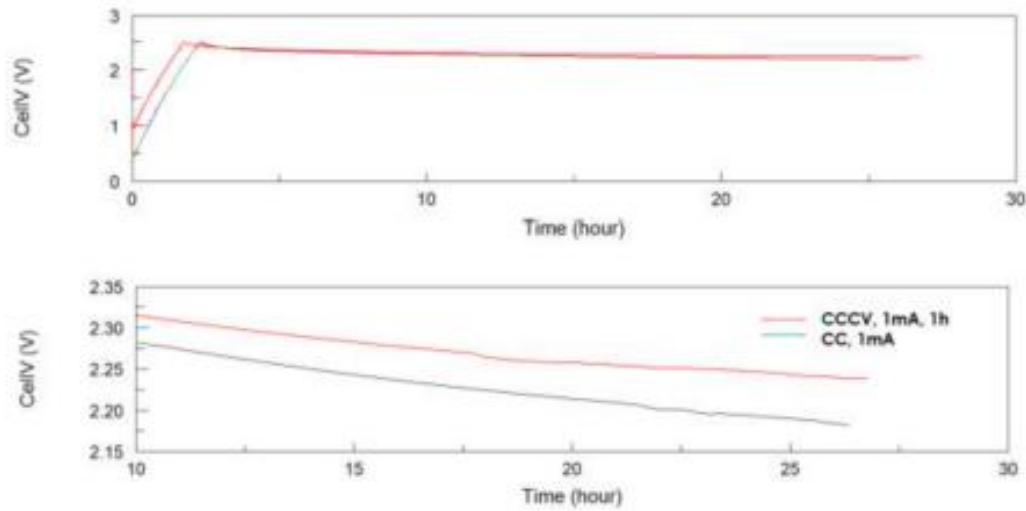

Figure 4 Comparison between CC and CCCV with 4.7F supercapacitors (Dinglasan-Fenol, et al.,2016).

### E. Buck-Boost Converter

In this paper, the proposed DC/DC buck boost converter is used instead of a simple buck converter in goal to get a negative output from positive input also to compare the efficiency. The proposed circuit Consists of two diodes, two inductors, a MOSFET which will conduct as a switch and a capacitance. The main rule of the inductor and the capacitance is to store the energy and transfer it to the output depend on the switching mode (Soheli et al., 2018).

When the switch is ON the inductor L1 store energy, moreover the energy stored in the capacitance is released to the load.

When the switch is OFF the inductor L1 release energy to the load as well as the capacitance does.

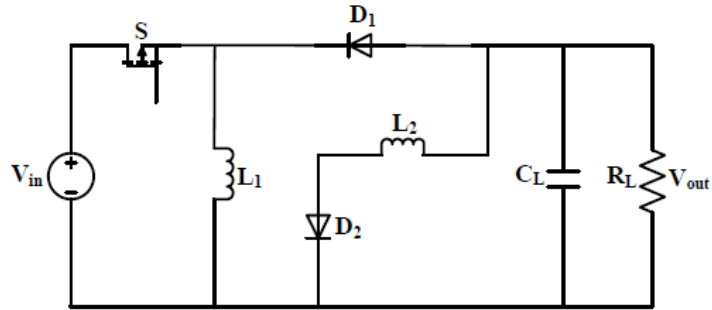

Figure 5 Circuit configuration of proposed DC-DC buck boost converter (Soheli et al., 2018).

The experiment shows that when a positive input voltage applied to buck converter the output voltage is totally positive, on the other side when a positive input voltage is applied to the proposed DC-DC buck boost converter the output is negative.

On the other hand, the efficiency of the DC-DC buck converter is higher that the efficiency of the proposed DC-DC buck boost converter in terms of frequency variation, contrariwise on the variation of load, the efficiency of the proposed DC-DC buck boost converter is greater than the efficiency of the DC-DC buck converter (Soheli et al., 2018).

## F. Boost Converter

In this paper a comparison between the boost converter, the Quadratic boost converter, and the double cascade boost converter in term of efficiency was proposed.

The Boost converter is a step-up converter where the output is greater than the input voltage, the input of the converter can be any type of DC source like batteries, thermocouples, solar cells, or supercapacitors, the boost converter contains, a capacitor, inductor, and two type of semiconductors a transistor and a diode. The boost converter conducts on two modes, the switch ON mode, where the inductor stored energy on its magnetic field, and the switch OFF mode the inductor switch polarity and become the source of energy by supplying the current towards the load and charge the capacitor on the same time (Boujelben et al., 2017).

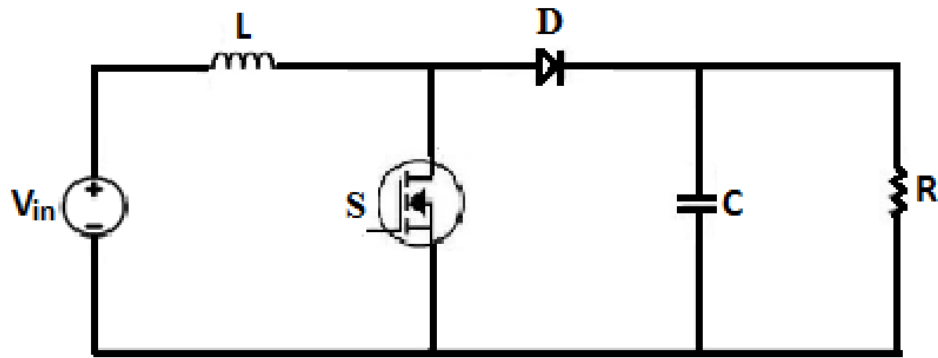

Figure 6 Circuit Diagram for the Boost Converter (Boujelben et al., 2017).

The Quadratic boost converter consists of a DC source, two inductors, two capacitors, four semiconductors (one MOSFET switch and three diode), and a load resistor. The circuit operate on two states, firstly the switch ON state, in this state the current is supplied to the inductors and the capacitor C1 which store the energy and the diode D2 is On, secondly, the switch OFF the diode D1 and D2 are ON, and the energy stored in the inductors is polarized inverse to charge the capacitors (Boujelben et al., 2017).

The double cascade boost converter is an interconnection of two boost converter associated in pair, which make it consists of two inductors, two capacitors, two diodes, and two MOSFET switch. there are two working modes, First, when the first switch S1 is ON the inductor store the energy field, second, when the second switch is S2 is ON the energy stored in L1 is released back into the circuit and the inductor L2 and the capacitor 1 start to store energy (Boujelben et al., 2017).

In this paper, the simulation has been done in SABER simulator, proves that the Quadratic boost converter can provide a high output voltage compared to the boost converter and the double cascade boost converter and it has a high efficiency (Boujelben et al., 2017).

## G. Buck Converter

This paper presents the configuration of the Buck converter, also the relation between the duty cycle and the efficiency of the converter.

When the switch is OFF, the energy stored in the inductors is reverse polarity and released into the load through the diode, the switch is going to be damaged in case of non-existence of the diode.

When the switch is OFF, the inductor is going to store the energy, and the output is going to be equal to the input due to the energy stored in the capacitor (Abhishek, et al., 2020).

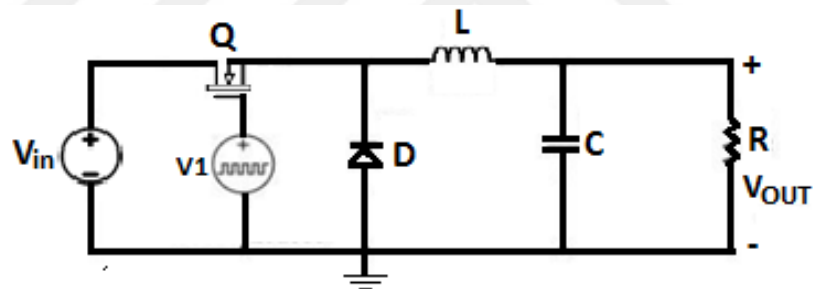

Figure 7 DC-DC buck converter circuit configuration.

The simulation has been done by utilizing NGSPICE, shows that the output voltage is lower than the input voltage and the efficiency is 83.79%. Also, the analysis shows that when a variable duty cycle is applied to the DC/DC buck converter, the efficiency of the converter increases when the duty cycle increases, it can even reach a maximum efficiency of 83.93% at 100% duty cycle. Moreover, the voltage gain will experience an enormous increase (Abhishek, et al., 2020).

## H. Fuzzy Logic Controller

In this paper the fuzzy logic controller was used in an autonomous vehicle to avoid obstacles due to their potential adaptabilities.

There are three important steps in the fuzzy logic controller:

- Fuzzification: in this stage the information captured by the sensor will be converted to a value that adapts to the fuzzy database.
- Inference mechanism: is based on several of If-Then rules AND/OR defined on the premise of the membership function characterized linguistically.
- Defuzzification: convert the output of the fuzzy logic controller into a crisp signal which will lead the behavior of the vehicle. There are many methods of Defuzzification, in this paper the “center of gravity” method is used (Singh, et al., 2020).

The usage of FLC in this experiment show that it's has a quick response that will reduce the error rate.

### **I. Battery and Supercapacitor Combination**

In this paper, [S. PAY AND Y. BAGHZOUZ] present two different connections of the battery and supercapacitor, the first connection is when the battery is directly connected to the supercapacitor, and the second connection is when they are connected through a buck- boost DC/DC converter, the results show that the supercapacitor reduce the stress from the battery but still the function of the supercapacitor is limited, it requires a power controller which consists of two diodes, two switch, inductor and capacitor (Pay, et al., 2003)

Also, (Karangia, Jadeja, Upadhyay, and Dr. Chandwani), present in there paper a hybrid storage system (HSS) which consist of a battery module and a supercapacitor, to reduce the stress from the battery, the simulation results show that the stress in reduced from the battery also the efficiency was increased which add more reliability to the system. The efficiency can be improved by using different connection between the battery and the supercapacitor (Karangia, et al., 2013).

### III. THE MAIN INTELLIGENT ENERGY STORAGE SYSTEM

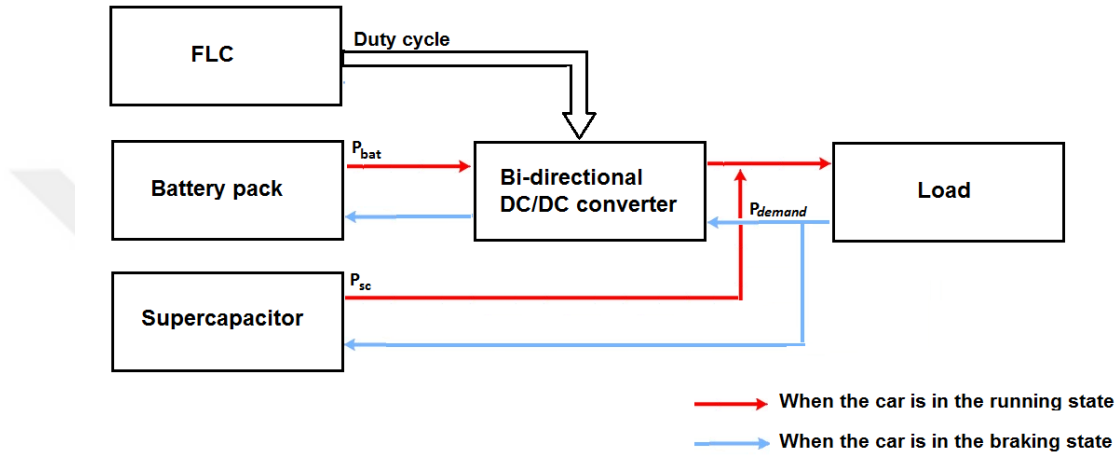

Figure 8 Intelligent energy storage system structure.

As it's shown above the whole energy storage system it consists of lithium-ion battery pack, Supercapacitor, and a parallel DC/DC bi-directional converter (Aharon, et al., 2010). The fuzzy logic controller is used to calculate the duty cycle according to human experiences.

The battery energy capacity should be calculated to be suitable for the load power demand, which can be calculated according to (Xu, et al., 2017), as follow:

$$S = \frac{E}{e_0 \times M}$$

Equation 1

Where  $S$  is the driving distance,  $e_0$  is the energy consumption, and  $M$  is the mass of the vehicle.

The supercapacitor's energy capacitance should also cover the load power demand, according to (Xu, et al., 2017), should be calculated as follow:

$$W_{cap} = \frac{1}{2} C (U_{max}^2 - U_{min}^2)$$

Equation 2

With  $W_{cap}$  is supercapacitor's energy capacitance, the  $C$  is the supercapacitor nominal voltage,  $U_{max}$  is the nominal voltage, and  $U_{min}$  is the dropout voltage.

The Bi-directional DC / DC Converter it explained below.

The multiple input, multiple output fuzzy logic controller used is briefly explained and shown in the methodology section.

## A. Source of Energy

### 1. Lithium-ion Battery

The high efficiency, the high energy density and that they are considered as one of the safer batteries compared to other system, makes them the most used in the manufacture of the electrical vehicle. Other advantages of the li-ion batteries:

- low self-discharge.
- Low Maintenance because is not affected by the memory effect.
- provide extremely high current when its needed (Battery university, 2021).

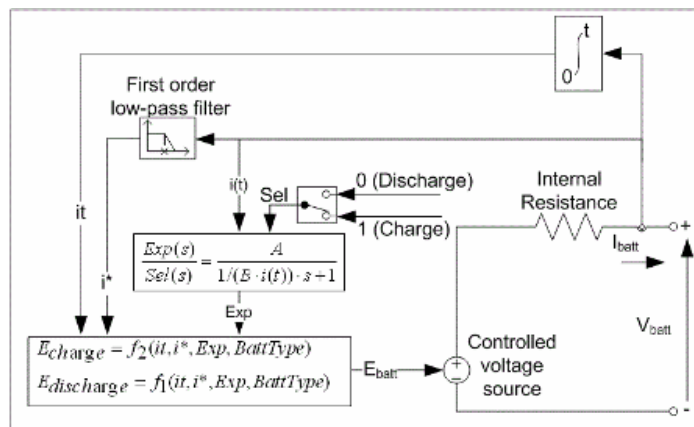

Figure 9 The equivalent circuit of MATLAB/SIMULINK li-ion battery (Mathworks, 2022).

As it's shown in the Figure above the lithium-ion SIMULINK/Matlab model is composed of an internal resistance which control the current, the same current its filtered by a low-pass filter to attain dynamic average current, the current is integrated to obtain the capacity extricated by the battery. The result of the of the integration in insert in one of the dynamic equations to control the battery voltage, which is going to be selected by the switch depend on the function mode of the battery charging or discharging.

One of the most important characteristics of the batteries is the state of charge (SOC), which represente the rate of the left energy on the battery compared to the maximum energy. There is two units to calculate the SOC are the percentage and points (1.0 = fully charged and 0% or 0.0 = empty). To conserve the battery, Keep the SOC Between 100% and 75% as far as we can.

## **2. Supercapacitor**

The typical capacitor has the ability to store and release the energy very quickly compared to the batteries, in the other hand, it cannot store a big amount of energy which makes it unfit for use in the automobile industry. The supercapacitor also called as Ultacapacitor come with high power density, and considered as the future of the energy storage system which bridge the crevice between the normal capacitors and the batteries (Joshi, et al., 2019). Other advantages of the supercapacitor are:

- High number of charge or discharge cycle.
- long lifetime.
- Ability of providing large amount of power in a short time.
- Low temperature execution (from -40oC to 70oC).

## **B. Bi-directional DC / DC Converter**

It is a composition of two types of converters buck, and boost converter to permit the energy to flow in both directions depend on the requirements of the system, respecting the condition that the energy flow should be the opposite for each working mode. Further the Bi-directional DC / DC Converter can control the direction of the energy flow, protect the

component, provide high efficiency and high performance compared to one-way converter (Shen, et al., 2014).

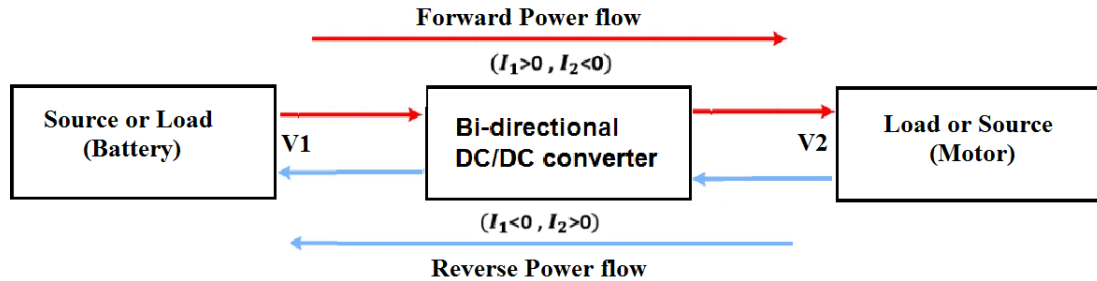

Figure 10 The energy flow in the bi-directional DC/DC converter.

It has two modes of conducting, the step up mode and the step down mode, in the step up mode the Q1 conduct depend on the DC, and in the step down mode it is the Q2 which conduct depend on the DC. A little time out is given between both the mode so that cross conduction can be maintained a strategic distance (Ravi, et al., 2018).

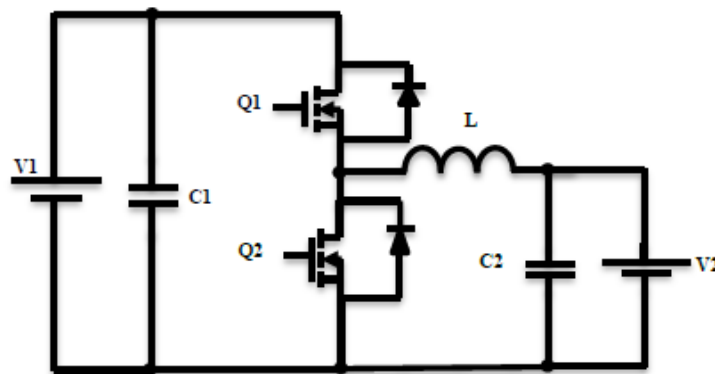

Figure 11 Buck/Boost bi-directional DC-DC converter (Ravi, et al., 2018).

## 1. Boost Converter

The first conducting state of the Bi-directional converter is the boost converter, which conduct from the left to the right (from the source to the load), which has as a main concept stepping up to voltage. The boost converter itself has three different operating modes: the first mode presented in Fig 10(b), the switch is OFF, and the capacitor is charging by

the input voltage. The second mode shown in Fig 10(a), the switch is ON and the diode is OFF, the inductor store the energy, and the rest flow through the MOSFET and return to the input source. The third mode where the switch is turned OFF again, the current flow to the inductor, the capacitor and power the load. The load is energize by the input current and the energy stored in the capacitor. The capacitor cannot discharge through the MOSFET due to blocking diode (Components101, 2019).

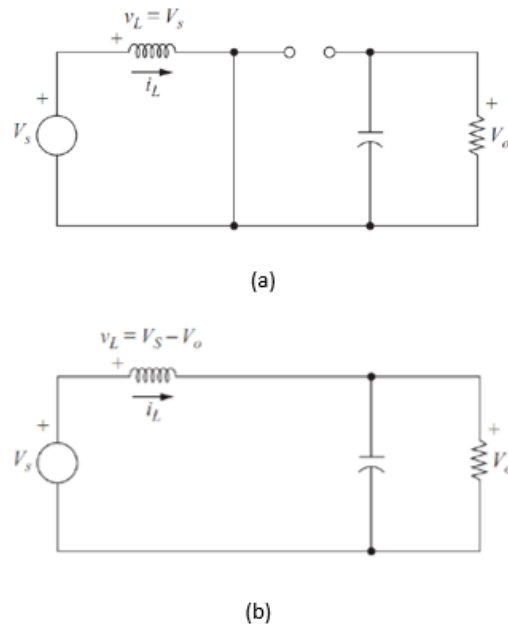

Figure 12 Switching sequence of the boost converter (Tutkun, 2021).

The parameters of the boost converter can be calculated as bellow (Tutkun, 2021).

$$D = 1 - \frac{V_0}{V_s}$$

Equation 3

$$L = \frac{V_s \times D}{\Delta i_L \times f_s}$$

Equation 4

$$C = \frac{D}{R(\Delta V_0/V_0)f}$$

Equation 5

Where  $D$  is the duty cycle,  $V_0$  is the input voltage,  $V_s$  is the input voltage,  $\Delta i_L$  is the inductor ripple current,  $R$  is the load resistor,  $\Delta V_0$  is the output voltage ripple, and  $f$  is the switching frequency.

## 2. Buck Converter

The second mode in the buck converter, which has as a main concept stepping down to voltage.

The operation of the buck converter can be summarized in some steps, the first step shown in the Fig 11(a), the switch in On, the current flow directly to charge the capacitor, but since the inductor limit the charging current because itself is storing the energy on it magnetic field, the voltage across the capacitor is not the same as the input voltage, the second step shown in the Fig 12(b), where the switch is OFF, the inductor reverse polarity to charge the capacitor and energize the load through the diode (Components101, 2019).

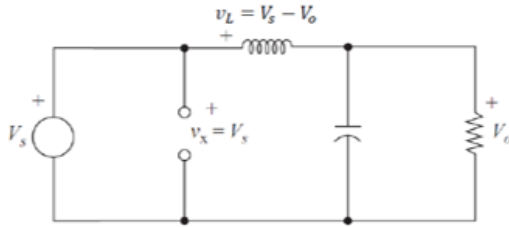

(a)

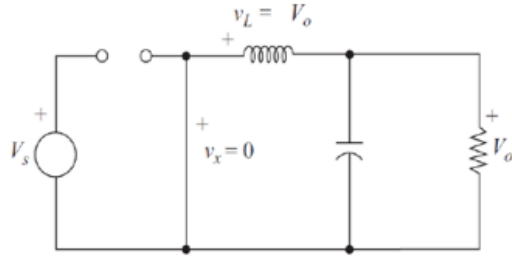

(b)

Figure 13 Switching sequence of the buck converter (Tutkun, 2021).

The buck converter parameters can be calculated as bellow (Tutkun, 2021).

$$D = \frac{V_o}{V_s}$$

Equation 6

$$L = V_o \frac{1 - D}{\Delta i_L f}$$

Equation 7

$$C = \frac{1 - D}{8L(\Delta V_o/V_o)f^2}$$

Equation 8

Where  $D$  is the duty cycle,  $V_o$  is the output voltage,  $V_s$  is the input voltage,  $\Delta i_L$  is the inductor ripple current,  $L$  is the inductor,  $f$  is the switching frequency, and  $\Delta V_o$  is the output voltage ripple.

### C. Parallel DC/DC Bi-directional Converter

As an extra step to improve the performance of the Bi-directional DC / DC Converter and reduce the output current ripples (Nguyen, et al., 2020) the parallel staggered DC/DC bi-directional converter is used.

Basically these strategy can be done by making a parallel branches for the boost and the buck modes and between each branch there should be a phase shift with half cycle so the current ripples cancel each other even in same cases ripples can be totally cancelled.

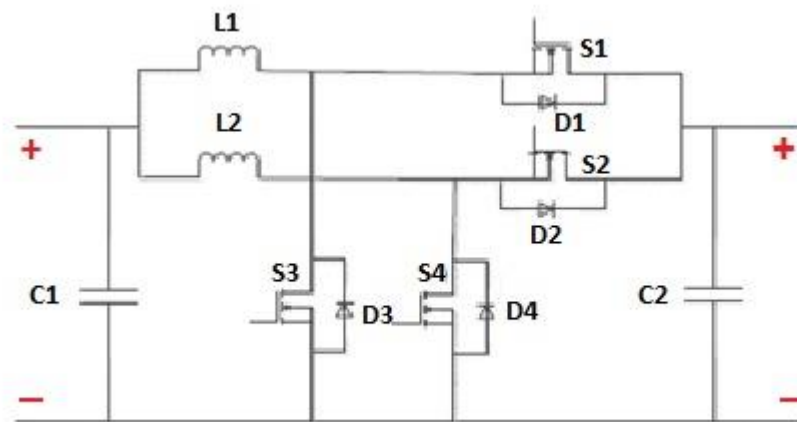

Figure 14 Parallel staggered DC / DC converter.

### D. Pulse Width Modulation

It has many different uses because it allows us to finally control different electronic devices for example, the brightness of lighting whether that is a standard bulb or LEDs also allow us to control the speed of motors. The pulse width modulation allows us to make very efficient power supplies such as step-up, step-down, and regulated power supplies all known as switch mode power supplies, the switch mode in the names refers to the pulse width modulation technique (Hamza, et al., 2014).

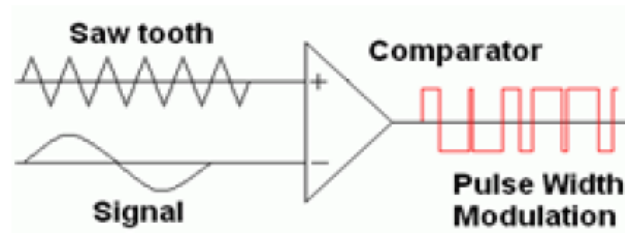

Figure 15 Principles of PWM generation (Hamza, et al., 2014).

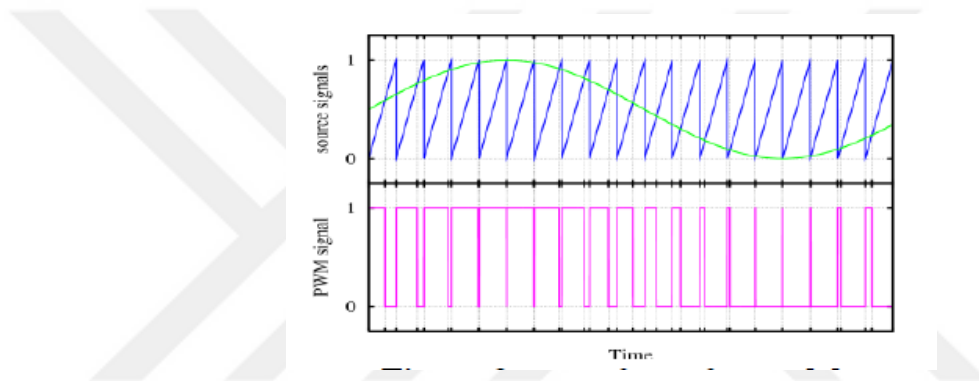

Figure 16 Wave form of PWM (Hamza, et al., 2014).

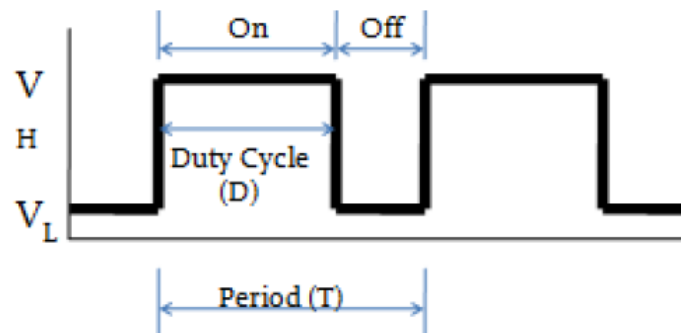

Figure 17 PWM signal (Hamza, et al., 2014).

There are two main factors that control the behavior of the PWM: the duty cycle and the frequency. The Duty cycle define the period where the PWM signal will be ON, and the frequency is to control the speed with what the PWM will complete the cycle.

## E. The Fuzzy Logic Controller

Is a way to model logical reasoning where the truth of a statement is not a binary (0 or 1), and it came to replace the traditional mathematical method. There are two main types of fuzzy logic controller, the Mamdani inference system and the SUGENO inference system (Wahid, et al., 2011).

The main difference between the Mamdani and the SUGENO inference systems is that Mamdani has an output membership function, but the SUGENO inference system can have either a crisp constant output or a linear function as the output.

Moreover, the Mamdani FIS is used in MISO (multiple input, single output) and MIMO (multiple input, multiple output) systems, while the SUGENO FIS is used only in MISO systems (Salman, et al., 2010).

In the figures below two examples of the Mamdani and SUGENO based fuzzy logic controller are shown.

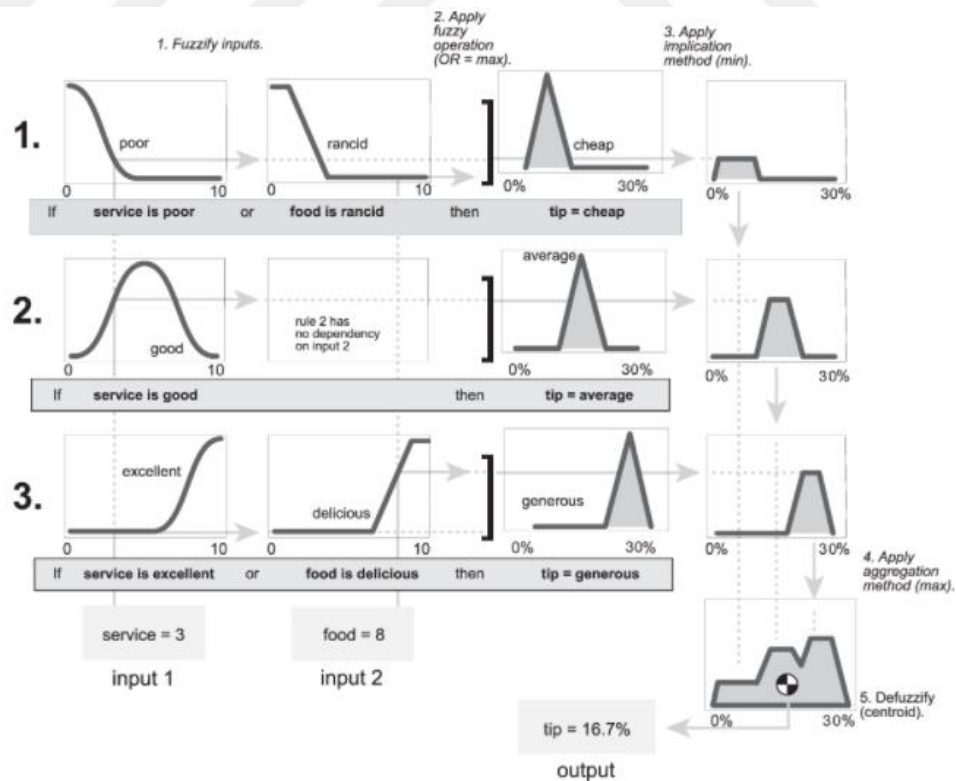

Figure 18 The inference process of a Mamdani system (Mathworks, 2022).

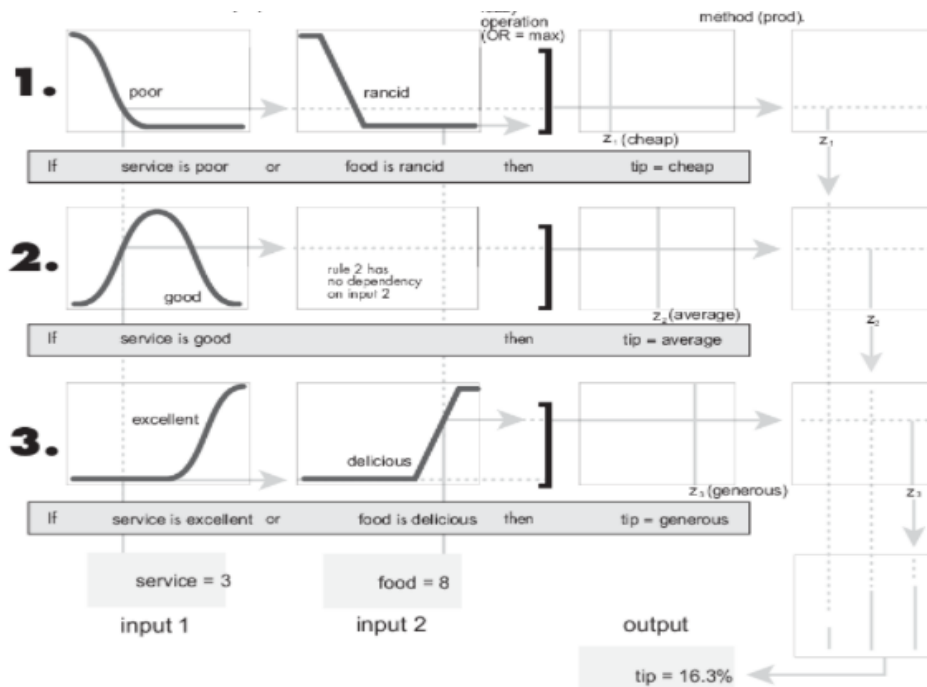

Figure 19 The fuzzy inference process for a Sugeno system (Mathworks, 2022).

There are many reasons why we use the fuzzy logic controller, the most important are two:

- Utilize human expertise and experience for designing controller.
- The fuzzy control rules (if- then rules) can be best used in designing a controller.

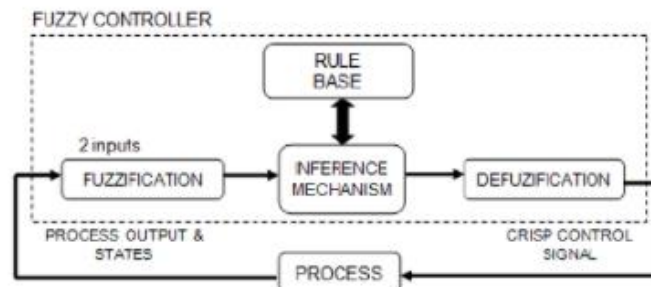

Figure 20 Block diagram of a fuzzy controller with details (Wahid, et al., 2011).

- **Normalization, input/output scaling factors:** it is used for scaling and normalizing input and output variables between (0,1) and (-1.1) intervals.
- **Fuzzifier:** converts crisp values to fuzzy values.
- **Fuzzy rule base:** stores knowledge about all input and output fuzzy relationships; it also has membership functions which defines the input variables to the fuzzy rules base and the output variables to the plant that is under control.
- **Inference mechanism:** Simulates human decisions for performing approximate reasoning to get the desired output.
- **Defuzzifier:** is the final handle of the fuzzy logic controller which Convert fuzzy values into crisp values.

## **F. Electrical DC Motors**

In general, the electrical DC motors consist of rotor, stator, windings, and commutator, but which make the different between the different motor is the distinctive arrangement of these components (Gieras, 2009).

A few parameters that must be taken into consideration whereas comparing over DC motors for choosing a best suited motor for required electric vehicle application are efficiency, power-to-weight ratio, torque-speed ratio, cost of controller, cost of motor. Is also fundamental to control the stream of alternating current depending on how the quickening agent is discouraged, so an accelerator position sensor is additionally required (Jape, et al., 2017).

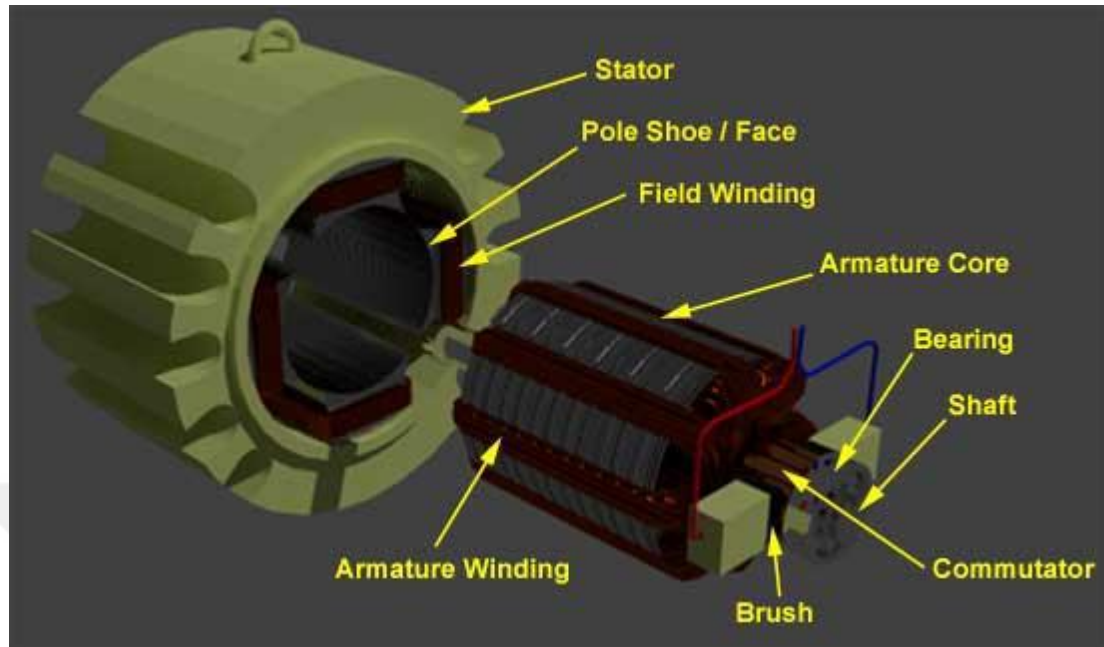

Figure 21 3D sketch of the DC. Motor (Mepits, 2014)

### 1. Dc Brushless Motor (BLDC)

The BLDC are widely used in control application due to its low cost and simple configuration. The rotor of a BLDC motor is a permanent magnet, the stator has a specific coil arrangement, by applying a DC power to the coil, the coil energizes and becomes an electromagnet. The operation of a BLDC is based on the simple force interaction between the permanent magnet and the electromagnet, in this condition when the coil A is energized the opposite poles on the rotor and the stator are attracted to each other, as the rotor nears coil A, coil B is energized and when as the rotor nears coil B, coil C is energized after that coil A is energized with the opposite polarity, this process is repeated and the rotor continues to rotate.

The sensors utilized within the BLDC are hall effect sensors which send which sends the data approximately to the energized coil at the minute, and the coil that will be energized in arrangement (Yedamale, 2003).

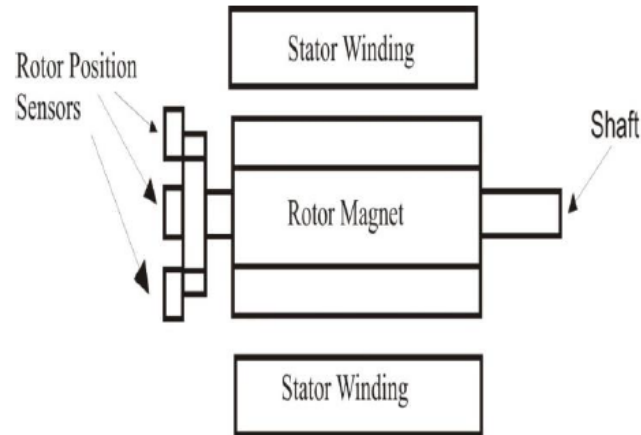

Figure 22 Basic arrangement of rotor and sensor elements in BLDC motor (Jape, et al., 2017).

## 2. Brushed Dc Motor

In the Brushed DC motor, the coils are wire to the commutator on the spindle, this commutator has a split rings which make the current reverse polarity with a cycle depend on the number of poles which activate each coil in sequence and make the motor turn.

The brushed Dc motor comprises of a commutator and brushes. The Brushes are usually made of graphite or carbon, sometimes with Commutators added dispersed copper to improve conductivity. The bruch holder encompasses a spring to preserve weight on the brush as it shortens.

One of the advantages of the brushed DC motor is that it can accomplish a high torque during a low speed (Jape, et al., 2017).

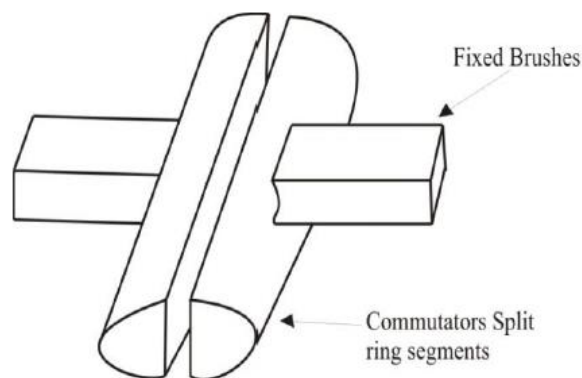

Figure 23 components arrangement of brushed dc motors (Jape, et al., 2017).

### **3. Switched Reluctance Motor**

The rotor and the stator of SRMs have salient poles, also the rotor has no winding. Contrary to the cylindrical stator that has two phase winding or more depend on the utilization of the motor, moreover, In the rotor and stator of the SRMs there is no magnets.

When the stator, is energized, variable reluctance is set up within the discuss hole between the stator and the rotor, in this time the rotor will tend to move to a position with slightest reluctance which is going to cause a torque (Jape, et al., 2017).



## IV. METHODOLOGY

In this section, an analysis and discussion for the energy storage system that have been designed using many technics and strategies as a battery pack, supercapacitor, Parallel staggered DC / DC converter, and a Fuzzy logic controller. The system was constructed and simulated on Simulink/MATLAB platform.

### A. Purpose and Importance

The energy storage system is the main part of any electrical vehicle due to its ability to affect the electrical vehicle, the main goal of this thesis is to reduce the pressure that would be done on the battery pack in any sharply increasing or decreasing in the load current, by adding a supercapacitor the pressure on the battery can be reduces, which increase the life cycle of the battery pack and get a higher efficiency.

The proposed topology

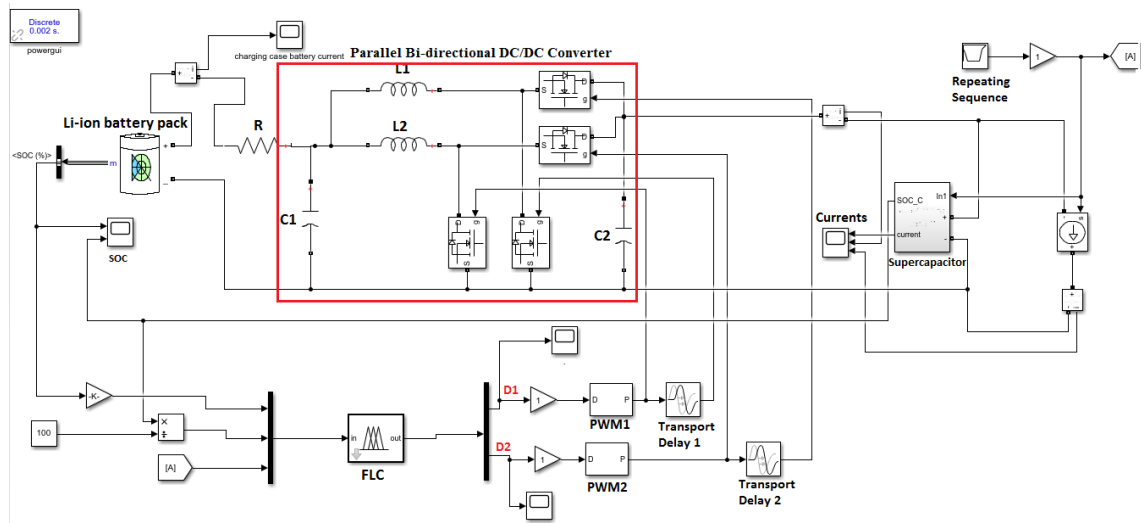

Figure 24 The entire system block diagram in MATLAB/SIMULINK platform.

## 1. Battery Pack

As it was mentioned earlier the battery energy capacitance should be calculated by using (1), which is directly related to the vehicle's energy consumption per 1Km (0.097kWh / (km)), the vehicle mass (3000 kg) and the trip distance, therefore the storage energy system was calculated based on 100Km trip distance, the battery pack capacity is to be 29.2KWh, and by taking self-discharge and the safety factors under consideration the battery pack capacity should be 30KWh,(rated voltage of 201.6 V and the rated capacity of 144.2 Ah), the internal connection of the battery pack can let us have the control on the output voltage and current of the battery pack.

## 2. Supercapacitor

The supercapacitor model used in this paper is a simple RC model connected in parallel with a resistance, and as it was mentioned earlier the supercapacitor energy capacitance is calculated by using (2), which is directly related to the supercapacitor parameters with a nominal voltage of 2.7V, and the capacitance of 3000F.

By calculating the energy of the supercapacitor model, we could design a supercapacitor that has as an energy capacitance 30KWh, which consists of six groups of 96 series in parallel with the composition of the rated voltage 259.2V, a capacity of 191.4F, and a resistance of 51.2m $\Omega$ .

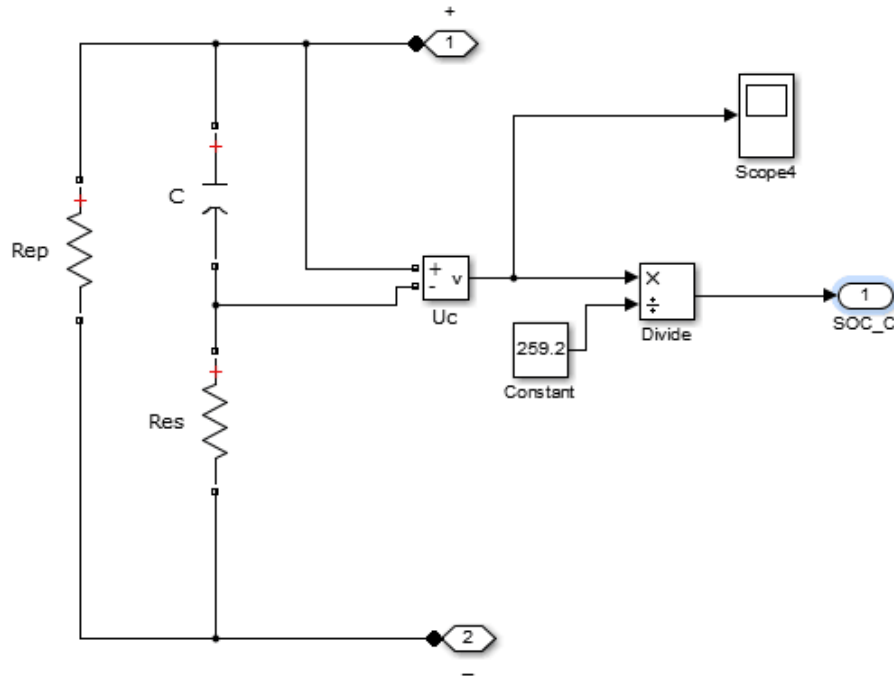

Figure 25 The used supercapacitor model.

### 3. Parallel Bi-directional dc/dc Converter

To improve the performance of the Bi-directional DC / DC Converter and reduce the output current and voltage ripples, the parallel staggered bi-directional DC/DC converter is used. Basically, this strategy can be done by making a parallel branch for the boost and the buck modes and between each branch.

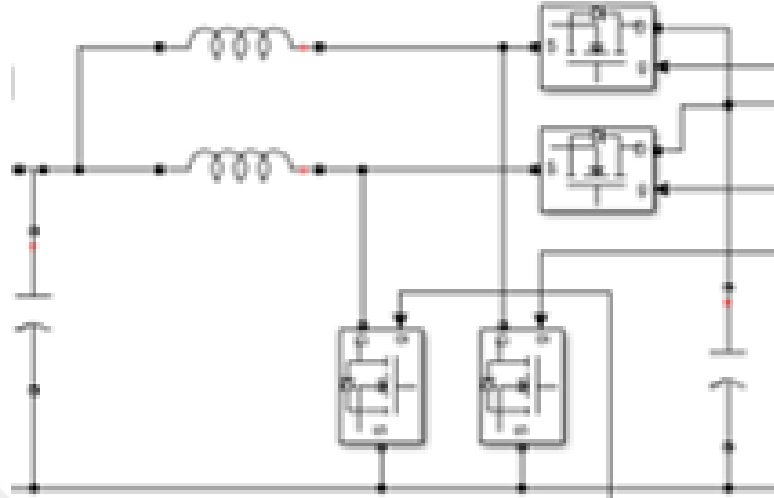

Figure 26 Parallel bi-directional DC / DC converter.

Table 2 DC/DC converter conduction mode table.

DC/DC converter mode	D1 and D2	D3 and D4	S1 and S2	S3 and S4
Boost mode	Forward bias	Reverse bias	Off	On
Buck mode	Reverse bias	Reverse bias	On	Off

For the current ripples cancel each other or even totally cancel it in some cases, a two phase PWM is used with a phase shift of half cycle  $\frac{1}{2}$ , and the conducting time of each cycle should be equal.

#### 4. The Fuzzy Logic Controller Design

The FLS used is a multiple input, multiple output type 1 fuzzy logic controller which is used to calculate the D (duty cycle) depending on the battery SOC, the supercapacitor SOC, and the output current  $I_0$ . Mamdani inference system was used in the FLS, the input and the output membership function, and the rules of the fuzzy logic controller are shown below, the fuzzy operator was selected to be AND.

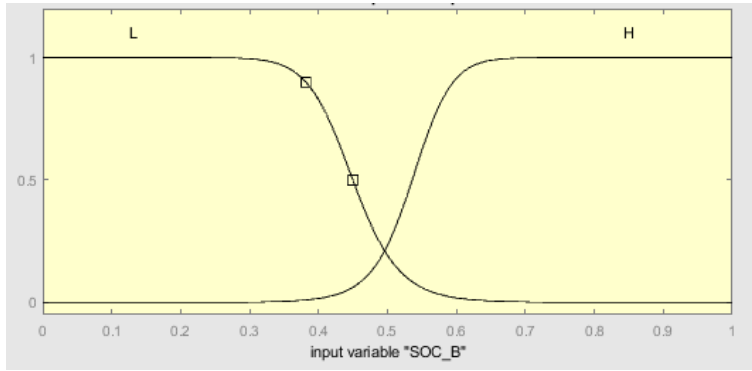

Figure 27 The membership function of SOC-B.

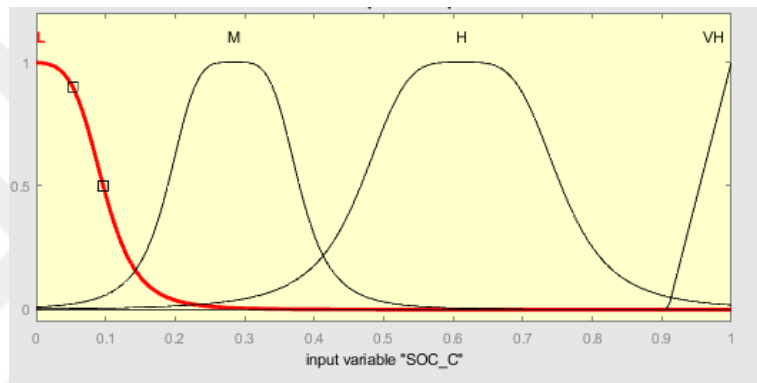

Figure 28 The membership function of SOC-C.

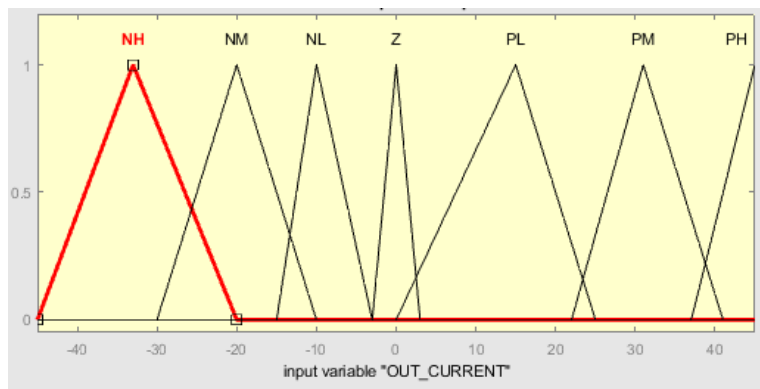

Figure 29 The membership function of Io.

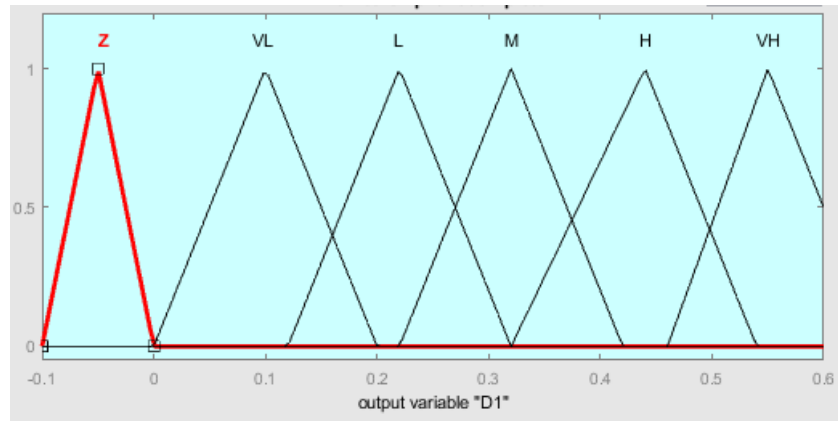

Figure 30 The membership function of D1.

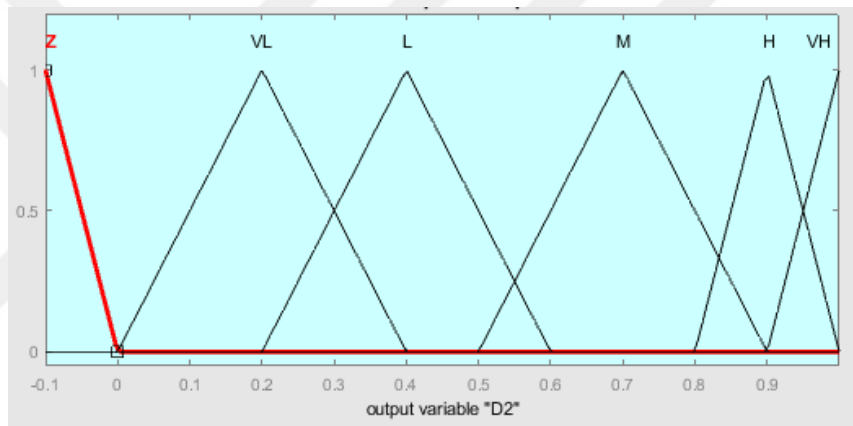

Figure 31 The membership function of D2.

The fuzzy rule base is the core of the fuzzy logic controller [16]. The rule base tables have been written based on experiment and is divided in two sections When the battery SOC-b of the composite power supply is high, which is shown in table 3, and when the battery SOC-b of the composite power supply is low, shown in table 4.

Table 3 Fuzzy rules table when SOC-b is high.

DQ1/DQ2		SOC <sub>c</sub>			
		L	M	H	VH
I <sub>o</sub>	NH	Z/Z	Z/Z	Z/Z	Z/M
	NM	Z/Z	Z/Z	Z/Z	Z/L
	NL	Z/Z	Z/Z	Z/Z	Z/VL
	Z	H/Z	L/Z	Z/Z	Z/Z
	PL	H/Z	M/Z	L/Z	VL/Z
	PM	H/Z	H/Z	M/Z	VL/Z
	PH	H/Z	H/Z	H/Z	VL/Z

Table 4: Fuzzy rules table when SOC-b is low.

DQ1/DQ2		SOC <sub>c</sub>			
		L	M	H	VH
I <sub>o</sub>	NH	Z/Z	Z/Z	Z/Z	Z/M
	NM	Z/Z	Z/Z	Z/Z	Z/L
	NL	Z/Z	Z/Z	Z/Z	Z/VL
	Z	M/Z	Z/Z	Z/Z	Z/Z
	PL	M/Z	L/Z	Z/Z	Z/Z
	PM	M/Z	L/Z	L/Z	Z/Z
	PH	M/Z	M/Z	L/Z	Z/Z

## V. RESULTS AND DISCUSSION

### A. Introduction

This paper focus on the energy control of power storage systems which are composed of a supercapacitor and a battery pack that are connected in parallel, and a DC/DC converter which plays the role of controlling the discharge current of the battery power. The SOC of both energy storage has as an initial state between 91 and 92%, the  $I_0$  is the load current (motor current), the  $I_b$  is the battery current, and the  $I_c$  is the supercapacitor current. The simulation is divided into two cases the charge and the discharge. Two different scenarios have been done to increase the pressure. Also impact analysis of the supercapacitor on the system have been done. The simulation has been done using MATLAB-SIMULINK.

### B. When The Vehicle is Within the Braking State (Charging)

The simulation is going to be in two scenarios, the difference between the scenarios is the load currents curves.

In the current figures the blue curve symbolizes the load current, the red curve symbolizes the battery current, and the black curve symbolize the supercapacitor current. In the SOC figures, the black line represents the battery pack SOC, and the red line represents the supercapacitor SOC.

## 1. Scenario 1

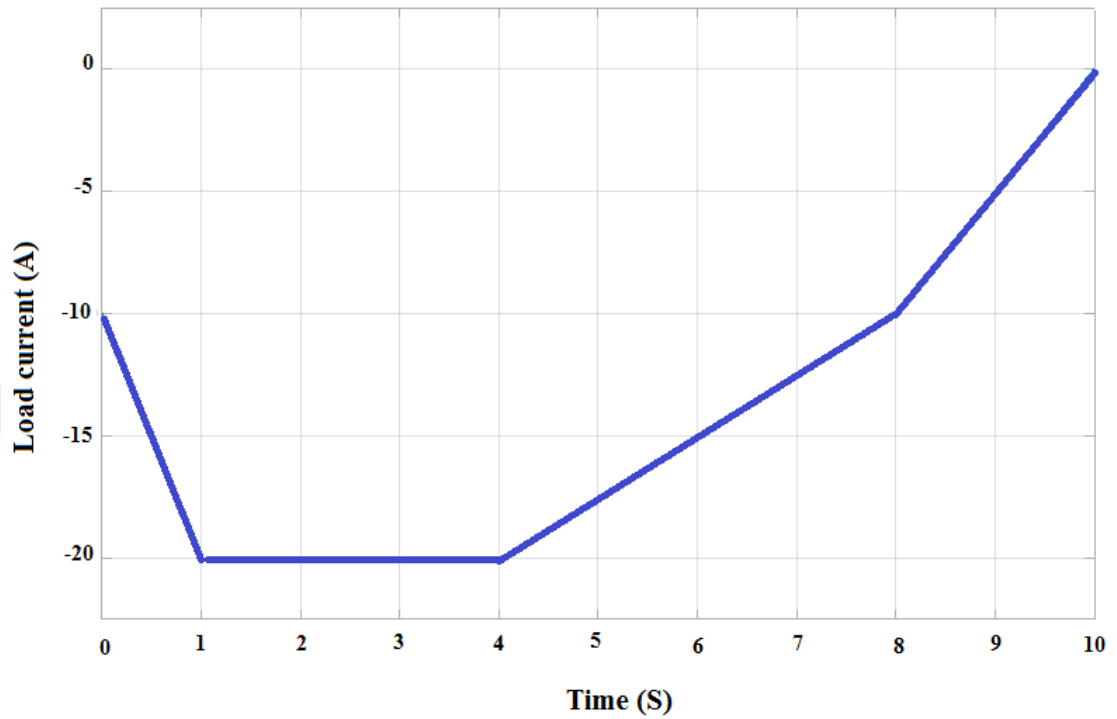

Figure 32 The load current during charging of the first scenario.

Since the load current  $I_0$  is negative means that the load energy is reversed to nourishes the battery and the supercapacitor simultaneously, it depends on the need of the storage system as is shown in Fig.33, moreover, the supercapacitor SOC get larger than the battery SOC which mean the supercapacitor prevent large power loading on the battery pack, in this case the buck converter mode is activated.

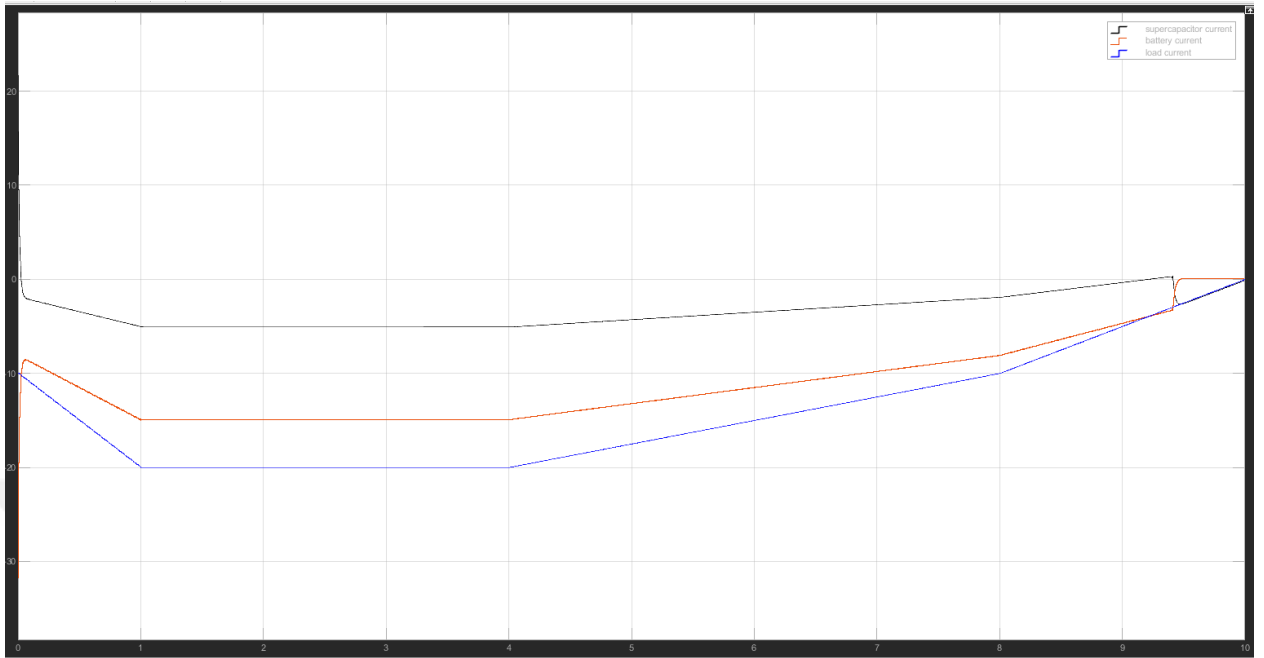

Figure 33 Changes in current during charging mode of scenario 1

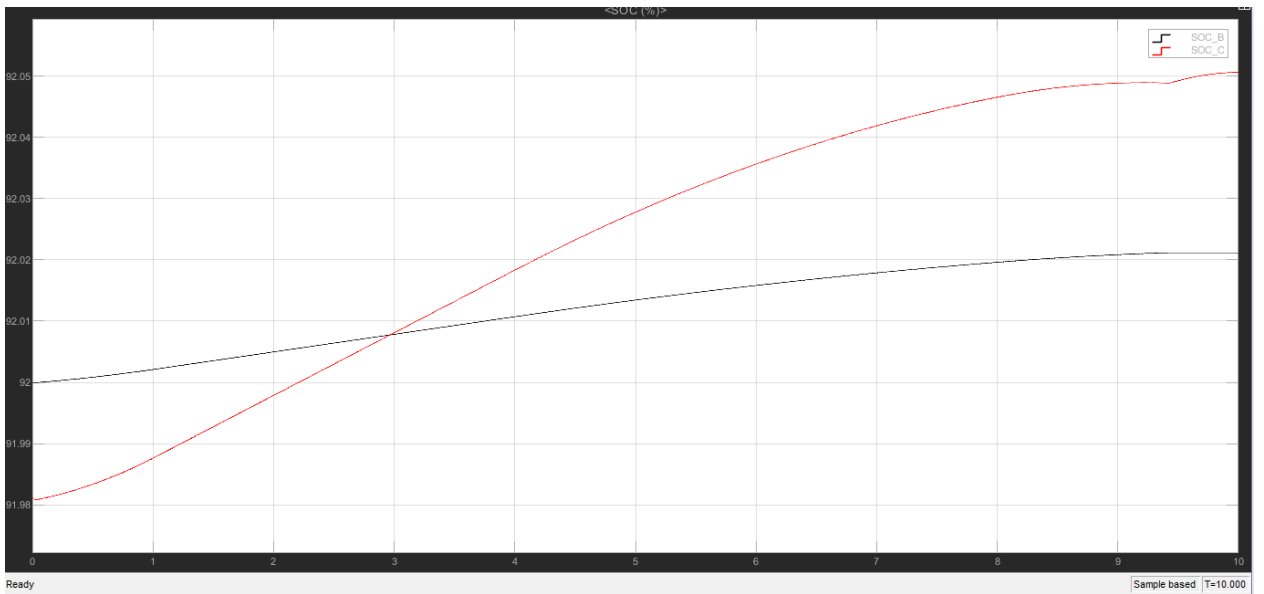

Figure 34: Changes in SOC during charging mode of scenario 1

## 2. Scenario 2

The purpose of the second scenario is to apply a maximum current (motor speed) for a long period to the system, and extend the simulation time, to see the behaviour of both battery and supercapacitor.

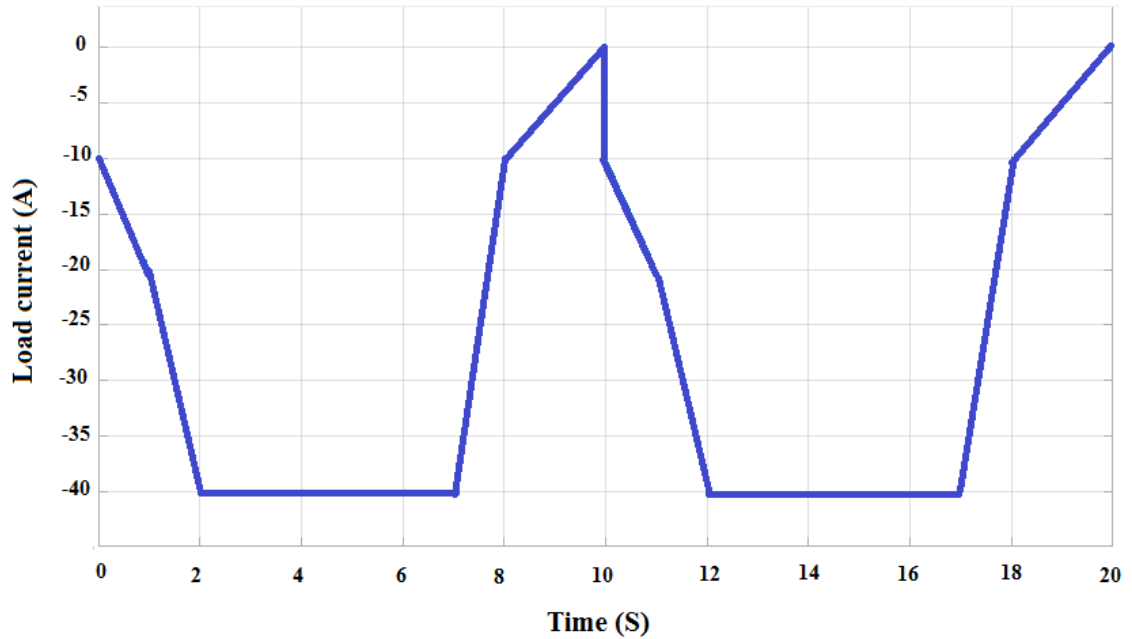

Figure 35 The load current during charging of the second scenario.

As we can see in figure 37, both the supercapacitor and the battery pack absorb the feedback current simultaneously during the whole trip. And in fig.38 shows that the supercapacitor SOC increased by 0.53%, while the battery's SOC only increase with a value of 0.05%. which mean that the supercapacitor protected the battery pack from high power.

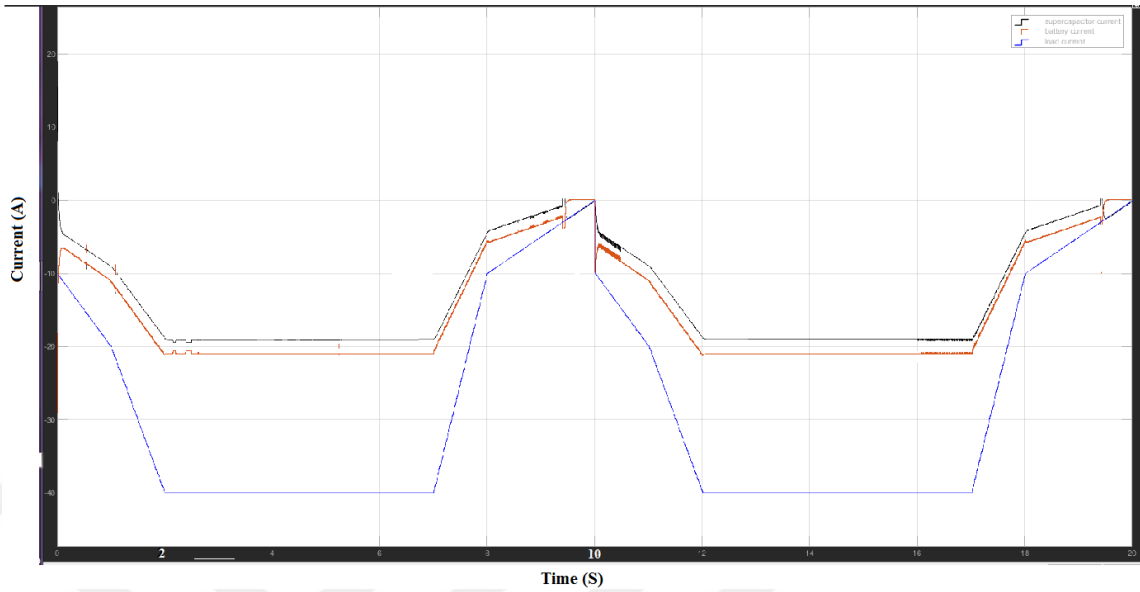

Figure 36 Changes in current during charging mode of scenario 2.

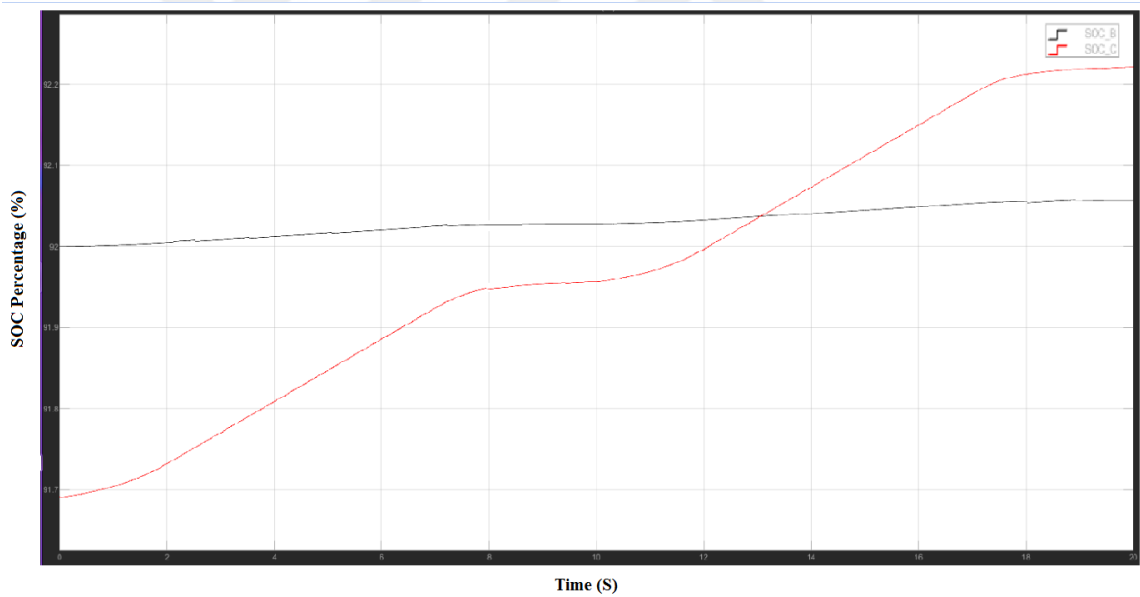

Figure 37 Changes in SOC during charging mode of scenario 2.

### C. When the Vehicle is Running Normally (Discharging)

The blue curve symbolizes the load current, the red curve symbolizes the battery current, and the black curve symbolize the supercapacitor current for the current figures. For the SOC figures the black line represents the battery pack SOC, and the red line represents the supercapacitor SOC.

## 1. Scenario 1

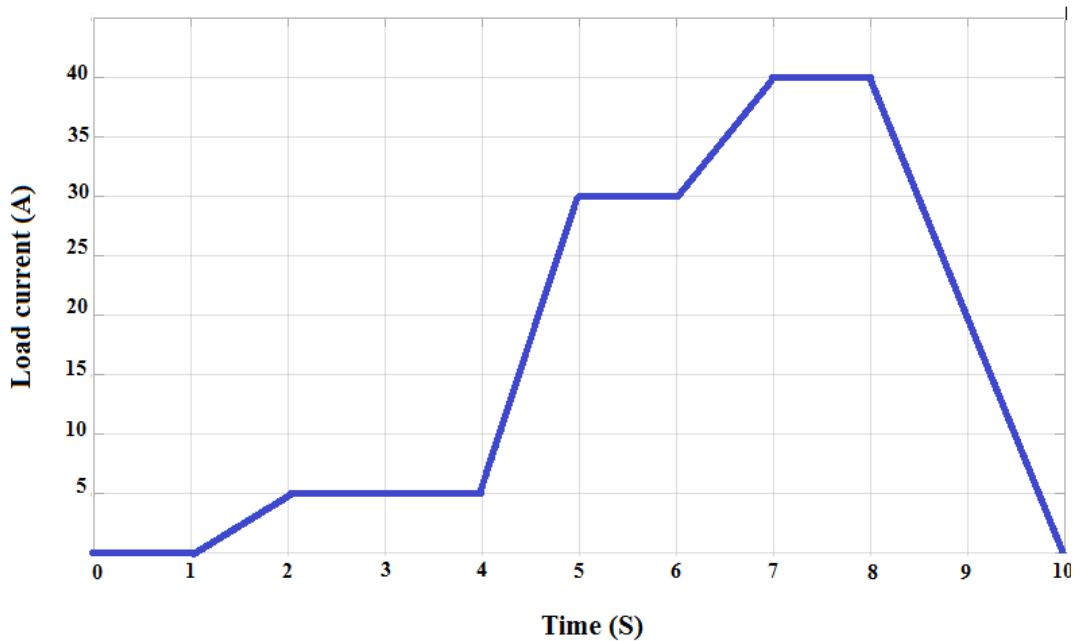

Figure 38 The load current during discharging of the first scenario.

The supercapacitor provides current alone to cover the load current until the 4<sup>th</sup> second, After the 4<sup>th</sup> second the battery and the supercapacitor provide the current simultaneously to cover the load current. The supercapacitor and the battery SOC get lower with the same proportion until the 4<sup>th</sup> second, after the 4<sup>th</sup> second the supercapacitor SOC get lower compared to the battery SOC. In this case the boost converter mode is activated.

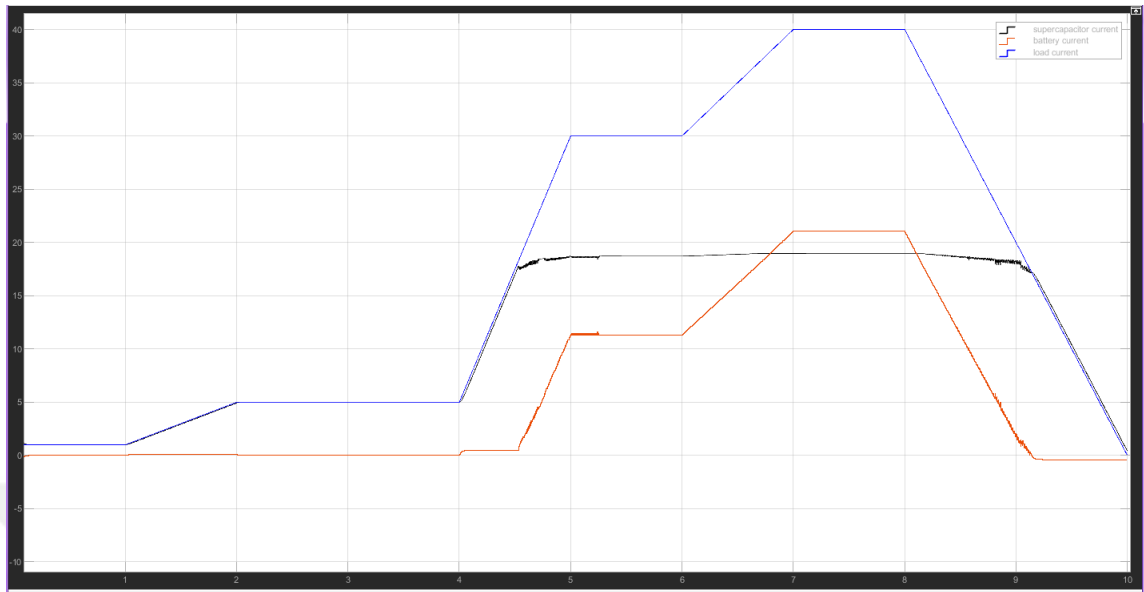

Figure 39 Changes in current during discharging mode in scenario 1.

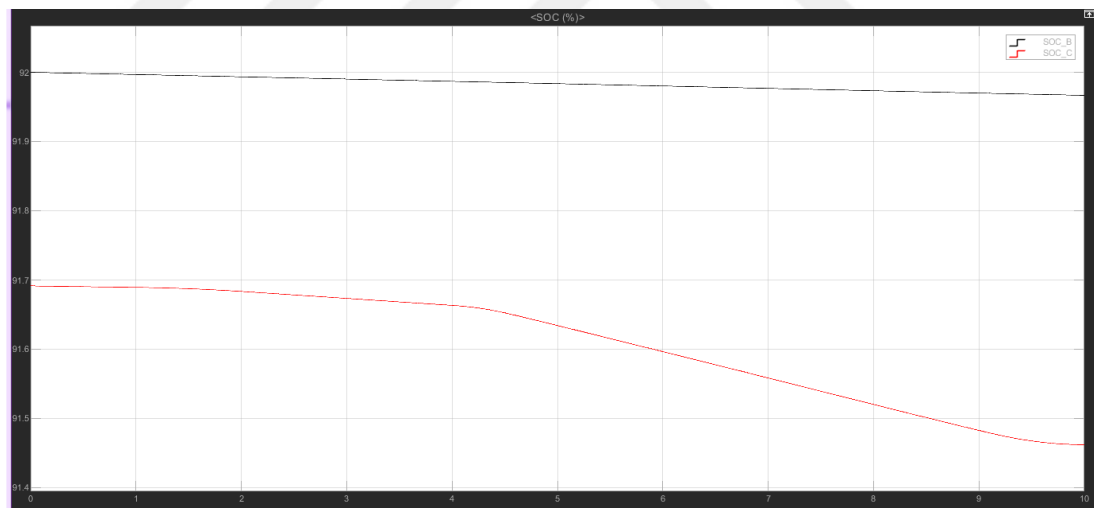

Figure 40 Changes in SOC during discharging mode of scenario 1.

## 2. Scenario 2

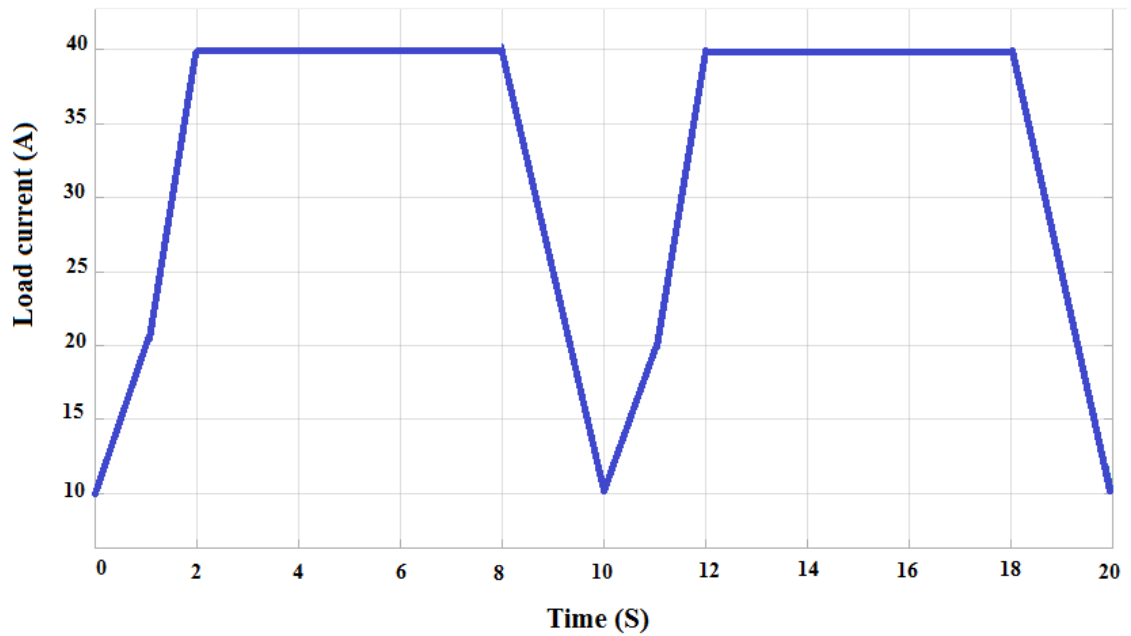

Figure 41 The load current during discharging of the second scenario.

Fig.43 shows that during the quick acceleration the battery current is 0 while the supercapacitor provides the necessary current to the load. During the rest of the trip both battery and supercapacitor provide the necessary current at the same time. And Fig.44 shows that the supercapacitor SOC decreased with an amount of 0.75%, while the battery's SOC only decreased with a value of 0.08%. with mean the supercapacitor greatly increase the pressure on the battery pack.

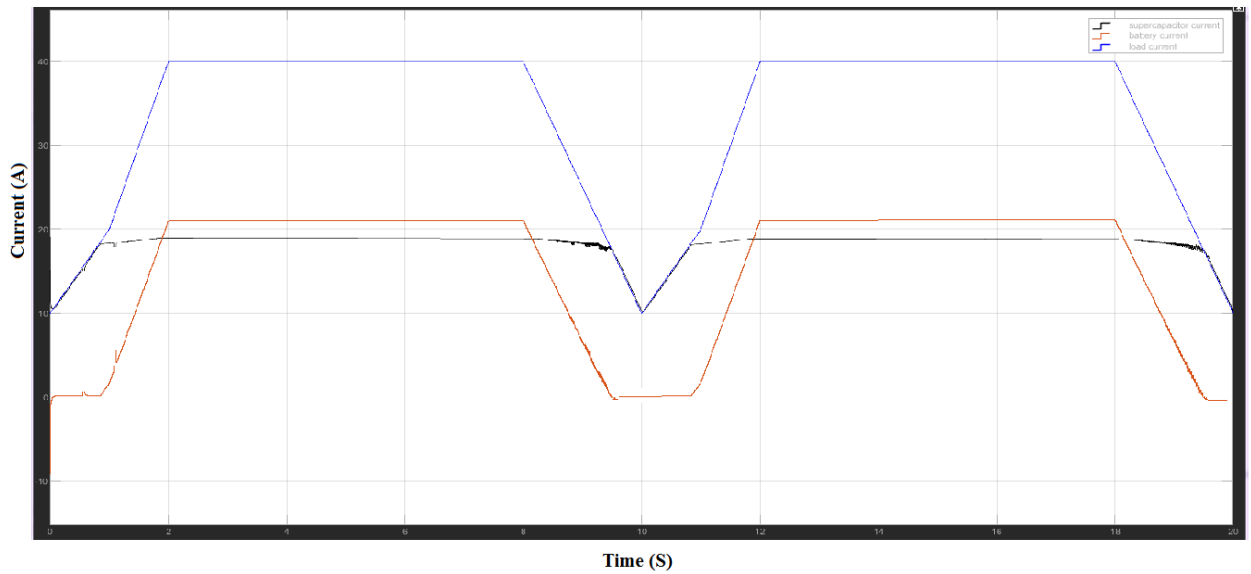

Figure 42 Changes in current during discharging mode of scenario 2.

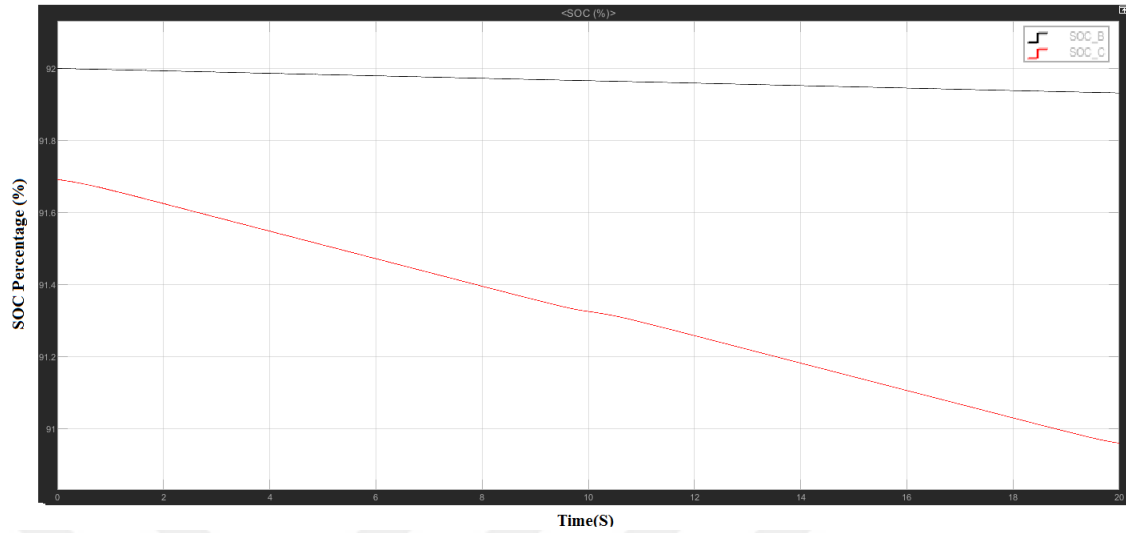

Figure 43 Changes in SOC during discharging mode of scenario 2.

Table 5 Results table of the first scenario.

Conduction Mode	Active Converter	Current higher value (A)		Current lower value (A)		SOC higher value (%)		SOC lower value (%)	
		Battery	Supercapacitor	Battery	Supercapacitor	Battery	Supercapacitor	Battery	Supercapacitor
-----	-----								
<b>Charging</b>	Buck	-15	-5	0	0	92.025	92.05	92	91.75
<b>Discharging</b>	Boost	22	18	0	1.5	92	91.7	91.97	91.46

Table 6 Results table of the second scenario.

Conduction Mode	Active Converter	Current higher value (A)		Current lower value (A)		SOC higher value (%)		SOC lower value (%)	
		Battery	Supercapacitor	Battery	Supercapacitor	Battery	Supercapacitor	Battery	Supercapacitor
-----	-----								
<b>Charging</b>	Buck	-22	-18	0	0	92.05	92.23	92	91.7
<b>Discharging</b>	Boost	22	18	0	10	92	91.7	91.92	90.95

#### D. Analysis the Impact of the Supercapacitor on the System

To analyze the effect of adding a supercapacitor to an electrical vehicle, the simulation of the system without the supercapacitor have been done in order to compare the battery's SOC percentage. The comparison has been done in case of the load current of the second scenario.

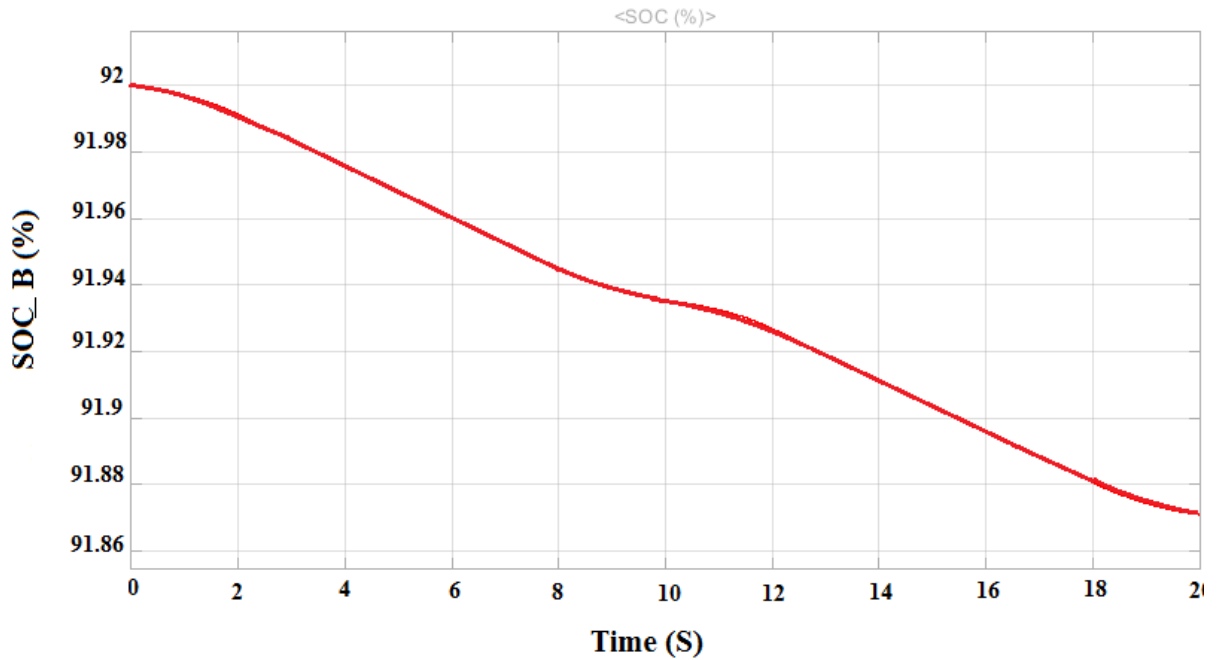

Figure 44 The battery's discharging SOC without supercapacitor.

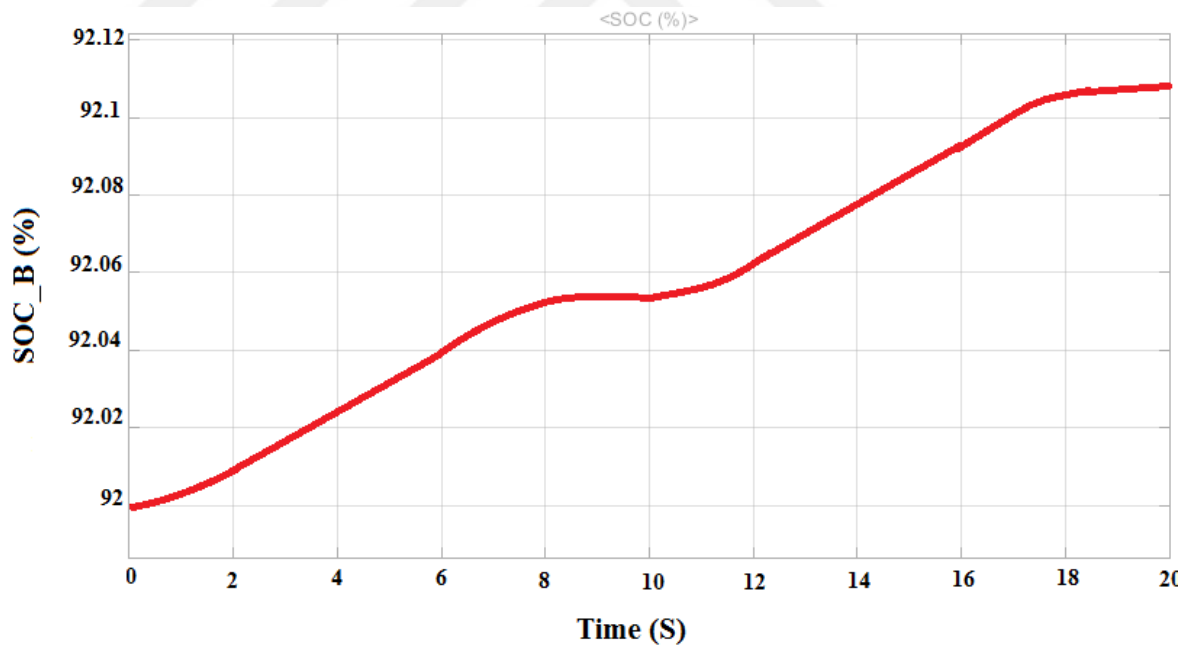

Figure 45 The battery's charging SOC without supercapacitor.

During the discharging mode the battery's SOC without the supercapacitor decrease until it reaches 91.87%, while with the supercapacitor the SOC percentage is 91.95%. And during the charging mode the battery's SOC without the supercapacitor increase until it arrives to 92.11%, while the battery's SOC with the supercapacitor increase until 92.05%.

## VI. CONCLUSION

In this thesis, intelligent energy storage system has been presented (IESS), which include battery pack, supercapacitor, parallel Bi-directional DC/DC converter, and fuzzy logic controller, for an electrical vehicle is simulated on two scenarios. The main aim of this Intelligent energy storage system is to reduce the pressure on the battery pack during the whole vehicle's trip which could lead to extend the battery pack life cycle. There are two operations functions (modes), which are charging and discharging, the charging mode happens while the vehicle braking which activates the buck mode of the DC/DC converter, and the discharging mode happens while the vehicle running which activates the boost mode of the DC/DC converter. Moreover, the intelligent energy storage system controls the vehicle's speed (motor's current) by using the PWM technique which is produces by the DC/ DC converter. Then the Fuzzy logic controller was designed to calculate the Duty cycle (D) which controls the battery pack output current, and by doing so the pressure in the battery pack would be decreased. As an additional step parallel DC/DC converter strategy was used to reduce the current ripples as possible. As expected, the directly connected supercapacitor would reduce the impact of any sharply increasing or decreasing of the load current by providing the necessary current during the quick acceleration and by capturing and storing the feedback current. The supercapacitor SOC in the two scenarios decrease and increase during the charging and the discharging respectively sharply the battery's SOC which can be considered as a protection to the battery pack. Moreover, the analysis of a adding a supercapacitor to the system by simulating a battery pack of the same system without a supercapacitor, the comparison between the two systems shown that the battery's SOC without a supercapacitor increase and decrease sharply compared to the system with a supercapacitor, which clearly shows the importance and the benefits which can be added to the electrical vehicles.

## VII. REFERENCES

### BOOKS

GHAREHPETIAN, B. G., AGAH, S. M. M., Distributed Generation Systems Design, Operation and Grid Integration, Butterworth-Heinemann, 2017.

GIERAS, J. F., Permanent Magnet Motor Technology 3rd Edition, Boca Raton: CRC Press, 2009.

### ARTICLES

ABHISHEK, R., ZOTING, P., RAGIT, P. 2020. "Design and Analysis of a DC -DC Buck converter and Boost Converter to Achieve High Efficiency by altering duty cycle and input voltage", **International Journal of Scientific and Research Publications (IJSRP)**, vol. 10, no. 6, pp. 731-738.

AHARON, I., KUPERMAN, A. 2010. "Design of Semi-Active Battery-Ultracapacitor Hybrids", **IEEE 26-th Convention of Electrical and Electronics Engineers**, pp. 593-597.

BOUJELBEN, N., MASMOUDI, F., DJEMEL, M., DERBEL, N. 2017, "Design and comparison of quadratic boost and double cascade boost converters with boost converter", **14th International Multi-Conference on Systems, Signals & Devices (SSD)**, pp. 245-252.

DINGLASAN-FENOL, S., CALUYO, F. S., SUGIMOTO, W. 2016. "Effect of Charging Methods on Self-Discharge and Leakage Current of Supercapacitors", **IEEE 4th International Conference on Control Engineering & Information Technology (CEIT)**.

HU, Y., WANG, Z., LI, X. 2020. "Impact of policies on electric vehicle diffusion: An evolutionary game of small world network analysis", **Journal of Cleaner production**, vol. 265, pp. 121-703.

HAMZA, S. A. E., BABIKER, A., MUSTAFA, N. 2014. "The Common Use of Pulse Width Modulation "PWM" Technique in Power Electronics", **International Journal of Science and Research (IJSR)**, vol. 3, no. 11, pp. 2129-2132.

- JOSHI, P. S., SUTRAVE, D. S. 2019. "Supercapacitor: Basics and Overview", **Journal of Information and Computational Science**, vol. 9, no. 12, pp. 609-625.
- JAPE, S. R., THOSAR, A. 2017. "Comparison of electric motors for electric vehicle application", **IJRET International Journal of Research in Engineering and Technology**, vol. 6, no. 9, pp. 12-17.
- KARANGIA, R., JADEJA, M., UPADHYAY, C., CHANDWANI, H. 2013. "Battery-Supercapacitor Hybrid Energy Storage System Used in Electric Vehicle Energy Efficient Automotive Technologies", **International Conference on Energy Efficient Technologies for Sustainability**, pp. 688-691.
- NGUYEN, D. D., BUI N.T., YUKIT, K. 2020. "Design and Optimization of Three-Phase Dual-Active-Bridge Converters for Electric Vehicle Charging Stations", **Energies**, vol. 13, no. 1.
- PAY, S., BAGHZOUZ, Y. 2003. "Effectiveness of Battery-Supercapacitor Combination in Electric Vehicles", **IEEE Bologna PowerTech Conference**.
- RAVI, D., REDDY, B. M., LETHA, S. S., SAMUEL, P. 2018. "Bidirectional dc to dc Converters: An Overview of Various Topologies, Switching Schemes and Control Techniques", **International Journal of Engineering & Technology**, vol. 7, no. 4.5, pp. 360-365.
- SALMAN, M. A., SENO, N. I. 2010. "A Comparison of Mamdani and Sugeno Inference Systems for a Satellite Image Classification", **Anbar Journal for Engineering Sciences**, vol. 0, no. 0, pp. 296-306.
- SHEN, Y., ZHAO, Z. 2014. "Bi-directional DC / DC converter and its practical application", **IEEE International Power Electronics and Application Conference and Exposition**.
- SOHELI, S. N., SAROWAR, G., HOQUE, A., HASAN, S. 2018. "Design and Analysis of a DC -DC Buck Boost Converter to Achieve High Efficiency and Low Voltage Gain by using Buck Boost Topology into Buck Topology", **International Conference on Advancement in Electrical and Electronic Engineering (ICAEEE)**, pp. 94-97.
- SINGH, M., DAS, S., MISHRA, S. K. 2020. "Static Obstacles Avoidance in Autonomous Ground Vehicle using Fuzzy Logic Controller", **International Conference for Emerging Technology (INCET)**, pp. 1-6.

ŞAHİN, M. E., BLAABJERG, F., SANGWONGWANICH, A. 2021. "Modelling of Supercapacitors Based on Simplified Equivalent Circuit", **CPSS Transactions on Power Electronics and Applications**, vol. 6, no. 1, pp. 31-39.

XU, R., WANG, Y. 2017. "Simulation of Composite Electric Power for Electric Vehicles", **IEEE International Conference on Mechatronics and Automation (ICMA)**, pp. 967-972.

YEDAMALE, P. 2003. "Brushless DC (BLDC) motor fundamentals", **Microchip Technology Inc**, vol. 20, pp. 3-15.

ZHUANG, W., LU, S., LU, H. 2014. "Progress in materials for lithium-ion power batteries", **International Conference on Intelligent Green Building and Smart Grid (IGBSG- IEEE)**.

#### **ELECTRONIC SOURCES**

URL-1 "Battery", MathWorks, <https://www.mathworks.com/help/physmod/sps/powersys/ref/battery.html>, (Access Date: 25 February 2022).

URL-2 "Boost Converter: Basics, Working, Design & Operation", Components101, <https://components101.com/articles/boost-converter-basics-working-design>, (Access Date: 10 January 2022).

URL-3 "Buck Converter: Basics, Working, Design and Operation", Components101, <https://components101.com/articles/buck-converter-basics-working-design-and-operation>, (Access Date: 14 January 2022).

URL-4 "DC Motor", Mepits, <https://www.mepits.com/tutorial/204/electrical/dc-motor>, (Access Date: 5 Mars 2022).

URL-5 "Is Lithium-ion the Ideal Battery?", Battery university, <https://batteryuniversity.com/article/is-lithium-ion-the-ideal-battery>, (Access Date: 15 December 2021).

URL-6 "Is Lithium-ion the Ideal Battery?", Battery university, <https://batteryuniversity.com/article/is-lithium-ion-the-ideal-battery>, (Access Date: 15 December 2021).

URL-7 “Mamdani and Sugeno Fuzzy Inference Systems”, MathWorks, <https://www.mathworks.com/help/fuzzy/types-of-fuzzy-inference-systems.html>, (Access Date: 3 February 2022).

### **OTHER SOURCES**

TUTKUN, N. “Boost converter”, Department of Electrical and Electronic engineering, Istanbul Aydin University, 2021.

TUTKUN, N. “Buck converter”, Department of Electrical and Electronic engineering, Istanbul Aydin University, 2021.



## RESUME

**Name Surname:** Hajar SRAHNA

### **EDUCATION:**

**Bachelor:** 2019, Faculty of Sciences and technologies Mohammedia, Faculty of Engineering, Department of Electrical Engineering.

**Master:** 2022, Istanbul Aydin University, Istanbul, Turkey, Faculty of Engineering, Department of Electrical and Electronics Engineering.

### **PUBLICATIONS FROM DISSERTATION, PRESENTATIONS AND PATENTS:**

- SRAHNA H., 2022. Controlling Energy Storage System by Using a Fuzzy Logic Controller and Analysis the Effects of Adding a Supercapacitor for an Electrical Vehicle. **International Journal of Electronics Mechanical and Mechatronics Engineering, IJEMM.**