



University of
Leicester

Individually Supervised Study (Physical Chemistry)

MSc Project

Supervised by

Prof. Andrew P. Abbott and Dr. Gero Frisch

Recovery of metals from mixed metal solutions

Prepared by

Salih Cihangir

August 2013

Table of Contents

Abstract	iv
Acknowledgements	iv
1.0 Introduction	1
1.1 Metal recovery in the history	1
1.1.1 Why do we need recycling metals selectively?.....	1
1.1.2 What are the gaps in hydrometallurgy that need to be filled?.....	2
1.1.3 Metal recovery processes and selectivity	4
1.2 Classification of ionic and eutectic liquids	7
1.2.1 Ionic Liquids	7
1.2.2 Discrete Anion or Second Generation Ionic Liquids	9
1.2.3 Deep Eutectic Solvents	11
1.3 Metal Processing with ionic liquids	12
1.3.1 Digestion of Metals	12
1.3.2 Extraction	13
1.3.3 Electrowinning and reduction	15
1.3.4 Cementation	16
1.4 Photo Reduction with different light sources	16
1.5 Recycling of printed circuit boards	18
1.6 Project Objectives	20
1.6.1 Project outputs	20
2.0 Experimental	21
2.1 Equipment and preparation	21
2.1.1 Preparation of DES samples	21
2.1.2 Preparation of silver and gold ion containing eutectics	22
2.1.3 Preparation of reducing agents	23
2.2 Experimental techniques used	23
2.2.1 <u>XRF</u> /UV/Laser	23
2.2.2 XRF/ <u>UV</u> /Laser	25
2.2.3 XRF/UV/ <u>Laser</u>	26
2.2.4 Analysis Techniques <u>UV</u> /SEM/EDX	26
2.2.5 Analysis Techniques UV/ <u>SEM</u> / <u>EDX</u>	26

2.2.6 Purification	27
2.2.7 Cyclic Voltammetry	28
2.3 Dissolution of photo-induced reducing agents	28
2.3.1 Sodium citrate tribasic dhydrate dissolution in eutectics	28
2.3.2 Citric acid dissolution in eutectics	29
2.3.3 LiBr dissolution in eutectics	29
2.4 Photo-induced reduction of silver and gold with different light sources	29
2.4.1 Ultraviolet light	29
2.4.2 630nm laser light	31
2.4.3 1064nm 5Hz 16mJcm-2 laser light	31
2.4.4 X-ray exposure	32
2.5 Chemically reducing of silver to selectively remove from solution	33
3.0 <u>Results and discussion</u>	34
3.1 Dissolution of photoinduced reducing agents.....	34
3.1.1 Conclusion	37
3.2 Photo reduction of silver and gold	37
3.2.1 UV/630nm and 1064nm lasers	37
3.2.2 X-ray experiments for reducing process of gold	39
3.2.3 Conclusion	44
3.3 Chemical reducing agents for selectivity of silver	45
3.3.1 Potential window shifts with target reducing agents	45
3.3.2 Conclusion	38
4.0 <u>Future work</u>	49
4.1 Improvements and suggestions on future work	50
4.1.1 Dissolution	50
4.1.2 Photoreduction	50
4.1.3 Chemical reducing agents with CV	51
5.0 References	52
6.0 Appendix	54

Abstract

The aim of the study is to recover some target metals, mainly valuable ones, such as gold and silver, in deep eutectic systems with the assist of chosen reducing agents by light exposure in which the energy of the photon has the ability of changing coordination number of the molecules due to change in the valance electron balance in the atomic scale. Main DES mediums used in this study are Ethaline 200, reline, and oxaline. Majority of the studied reducing agents are sodium thiosulfate, citric acid and lithium bromide chosen among others by depending on the previous studies in the literature, and the test results of their solubility. Light sources are ultra violet, 630nm, 1064nm continuum laser systems along with X-ray as generally low power scale. In the last part, some electrochemical tests have been practiced in order to work on redox potentials and the suitability of reducing agents used in DES systems. This study will be helpful to get an idea about the past studies of metal recovery along with recent literature searches. Additionally, the library of the DES soluble chemicals has been enhanced, and the main success of this study is the part of gold reduction which has been managed by X-ray. Although it seems industrially unsuitable, it still presents valuable amount of data in the comparison of latest studies.

Acknowledgments

I would like to thank Prof. Andy Abbot and Dr. Gero Frisch for their enthusiasm and encouragement, and National Ministry Education of Turkey for their support on my study. I am also indebted to with Scionix group members whose passion to learn and teach has inspired me to take my own passions.

This research and thesis dedicated to;

My mother and father Leyla-Turan CIHANGIR along with my little brother Serhat CIHANGIR, without your sacrifices, I cannot manage and sustain this research.

Many thanks for your endless devotion to my life

1.0 Introduction

1.1 Metal Recovery in the History

1.1.1 Why do we need recycling metals selectively?

In the late of 1800s and beginning of 1900s, metal industry was trying to provide demands of market by using most efficient and fast ways regardless to toxicity and harmfulness to the environment. Then, the nature has started to response this careless action of industry. In the part of metal producing, many of them were depending on basic leaching processes by using some acids and later organic solvents along with huge amount of water, which released to the nature with inadequate cleaning process, and carried toxic contaminants throughout the years. Today, there is a general and serious concept of all these environmental impacts called global warming. Global warming is the bisect points of the many non-eco-friendly activities in the world in which all the industries are responsible to obey some strict rules for the intention of future generation. In the part of metal recycling, toxic side materials and CO₂ gas emissions are quite important. Especially, developed and developing countries have manufactured different sorts of metal constituents, and these metal industries are required an important review, and regulations. According to data of BMRA (British Metal Recycling Association) in 2010, 400 million tons of metal have been applied on recycling process in all over the world, and just the United Kingdom has spent £5.6 in this industry. When it is considered the total amount of metals and the investment in annual base, it is easy to estimate how much harm it can be causes, and how much money recycling can be saved in the light of new methods, and technologies invented.

Metal recycling is a 'pyramid' industry which starts from small family companies to huge international businesses. For this reason, it is also very important to have some developments which can be applied even small business without required large amount of energy, which generally decrease the feasibility for small business. In a basic expression, adapting metal recycling in a country means using secondary raw materials and it decrease the use of natural sources and power along with less pollution rate due to less requirement to obtain new raw metal compounds from the nature.

As it is already known, there is no numerous ways to produce large amount of energy with least harm. In any case, nuclear or fuel based power station will be required for demanding energy of the metal industry, and producing energy basically means releasing CO₂ to the environment along with other harmful gasses. For the importance of this recycling concept, another data from BMRA emphasis

the significance of the metal recycling by just depending on the numbers as it is shown above in table.1;

Recycled Metal	% New Metals Produced from Recycled Amount	% Energy Saving
Aluminium	39	95
Copper	32	85
Lead	74	60
Steel	42	62-74
Zinc	20	60

The data in the table still does not contain how much pollution were prevented, and how much CO₂ and water with toxic contaminants released or how much cost saved in whole process. In light of this, we can easily see the critical significance of the recycling processes along with its requirements to be more developed and become more efficient in terms of cost, and decreased pollution as well as feasibility.

1.1.2 What are the gaps in hydrometallurgy that need to be filled?

Metal processing has comprehensive and unique technics due to different nature of raw materials, such as sulphides, oxides, phosphates, carbonates, complex slugs, sludges and alloys. Metal processing has been carried out for years with high temperature or hydrometallurgical processes mainly occur in very acidic or basic solutions due to nature of the ions. All of these processes consume high energy and cause significant environmental impacts. Today, strict restrictions have been applied just to cover

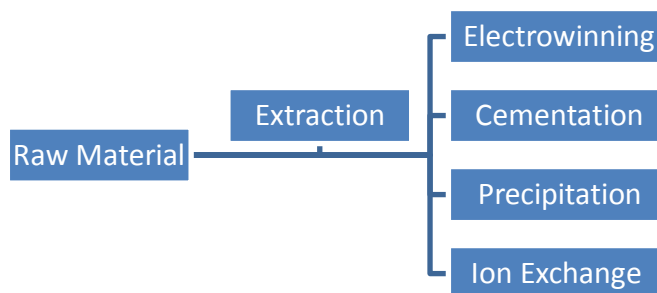
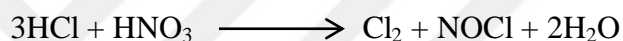

Figure 1: Basic flow chart of metal recovery redrawn from one of the references

Pollutions of previous manufacture processes [2]. Although, there is a few described ways for metal extraction, and manufacture in the beginning of 17th century, today there are many methods as classified in figure.1 [2]. The root of the hydrometallurgy comes from the desire of transmutation of

some base metals into the gold. Some of these practises were mainly depending on hydrometallurgy. However, there were many ambiguous points at that time. For instance, a peace of iron was dipped into a blue vitriol, i.e., copper sulphate, the iron was directly covered with copper, but not only it was covered with copper, but also blue vitriol was containing copper sulphate in it which was not known at that time, and found out later. Up to time of discovery of aqua regia, which was one of the most significant discoveries in the hydrometallurgy, by Jabir ibn Hayyan (720-813 AD) all chemistry science was turning around to find a way of metal transformation to the gold, and they was mainly using mercury, which is quite toxic. This noble metal was the prime occupancy of all. Aqua regia, also known as royal water, is the mixture of HNO₃ and HCl, and have the ability to dissolve gold while any acids were not effective^[3]. Aqua regia is still used today in gold refining process along with chlorine as one of its active constituents;



This reaction was practised widely in order to extract gold from its ores till the 1890s. Then, these sorts of unique extractions, metal obtaining processes were developed as parallel of the needs of the time. If these processes are briefly summarized in terms of development of hydrometallurgy, it can be arranged paragraph by paragraph in the order of development time in the following paragraphs^[3].

Certain kinds of soils containing putrefied organic matter that was leached for extraction of saltpeter (potassium nitrate, and salt of stone), and used as main requirement of manufacture of gunpowder by Vannoccio Biringuccio (1480–1539)^[3].

Extraction of copper in 16th century known as heap leaching made use of nature in order to complete whole process; pyrite containing copper sulphide minerals was put open-air area in bulk form for the rain interaction, and a solution containing copper sulphate was drained from the heap and collected in a basin after each rain. Then copper was precipitated by using iron, and this process was the basic of the today's cementations processes, and it is still widely used^[3].

In the 18th century potash, mostly used in soap and glass industries, was one of the demands in the market. The main source was Na₂CO₃, and it was coming from ashes of seashore vegetation, and the production was mainly depending on burning wood in areas which cause the clearing of the forest in large scale. Then, Leblanc process was discovered for production of Na₂CO₃ from NaCl^[2].

In the late 18th century, cyanidation process of gold treating from ores along with production of alumina with Bayer process were discovered, and became the starting point of modern hydrometallurgy. In essence, dissolving process of cyanide solution on gold was known from 1783 by Carl Wilhelm Scheele. It was studied later in 1846 in Germany by L. Elsner and discovered that

atmospheric oxygen has significant effect on process. Much later English scientist MacArthur patented the process in 1887, and it is known as cyanidation process. Second major discovery on this area was discovered by Bayer with the preparation of pure Al_2O_3 [3]. Later studies were also focused on hydrometallurgical metal separation from natural sources with high temperature conditions.

The question is here is to ask the side effects of these hydrometallurgical processes. A basic example from the past declared above, potash production, will give a perfect viewpoint of harms of traditional methods. At the time of 1767-1867, wood ash obtained domestic stoves and fireplaces as well as from lime kilns in order to agitate with water by following filtration and evaporation processes to obtain dry yield of potash. Unfortunately, 400 tons of hardwood was burn to get one ton required potash, and this also means annihilating roughly 10 acres of forest [3]. This is the direct effect it can be rapidly realized due to visual data of the treeless area seen in particular regions. There are also other problems, more harmful and difficult to cover which are depending on mostly water related processes, such as cyanide extraction applied in 19th century, their environmental impacts have been clarified recently in two different well detailed reports [4-5]. Consequently, it is quite important discovering new methods in order to take out all heavy metals from solutions along with neutralization practises due to possibility of salt discharge situations. In this way, it will hopefully possible to protect the nature.

1.1.3 Metal recovery processes and selectivity

In the main concept of metal extraction in hydrometallurgical term, metals are usually leached in aqueous based environment, and some physical conditions have impacts on leaching, such as pressure, temperature and air as oxidant [6]. Recovery process, which can be classified in four parts; Electrowinning, Ion exchange, Precipitation, and Cementation as it is also shown in fig.1, are generally related the part after leaching process in which aqueous media contains various metals, and ready to suitable process for metal cleaning.

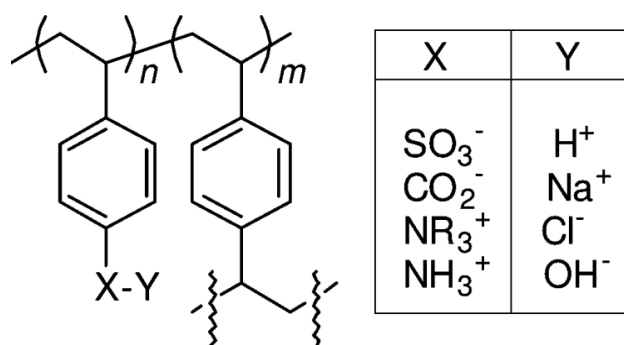
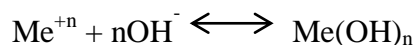

Figure 2: Polystyrene-divinylbenzene copolymers bearing ion-exchanging functional groups.

Electrowinning, also known as electroextraction, is the electrodeposition of metals from their ores that have been put in the solution or liquefied, generally obtained from leaching as aqueous medium. It is one of the most common methods, economical and straightforward, and generally used for the metals with positive redox potentials, such as silver, copper and gold. However, its potential windows in aqueous solutions is limited, and thus; it does not allow the same performance for some metals, such as chromium, and it does not have any effectiveness on some metals, such as aluminium. Electrodeposition process is mainly pH sensitive, and so; it is required to control pH properly, Pourbaix diagrams are widely available at this stage, so as to have ideal control on whole system. For the complex systems in which there are various sorts of metals dissolved, selectivity plays an important role. For this reason, some complexing agents have been widely used for different kinds of metals, such as cyanide or ammonia, allow controlling metal speciation in the solution. Hence, it becomes possible to manipulate order of the metal extracted metal species or deposited metal kinds in the processes. Ion exchange resins are generally used as reversible separating units and depending on mostly swapping ions. They are widely used in metal recovery and separation, ion substitution, acid base catalysis, as sensors or solid electrolytes in fuel cells, electrolyzers, and water purification units which mostly used at houses today ^[7-8]. In general, ion exchange units are formed polystyrene-divinylbenzene copolymers bearing ion-exchanging functional groups (Fig.2) ^[9]. Other sorts of exchange units can shortly be clarified as homopolystyrene and acrylic based resins and Nafion. Precipitation is one of the methods to separate desired, especially heavy ones, metals with their molecules form of hydroxides, sulphides-sulphates and carbonates. It has been mostly used for cleaning of industrial wastewaters. Hydroxide formation one of the most used metal precipitation methods, and it follows the basic reactions as below;



In the precipitation process, most helpful point comes from properties of heavy metals which are generally amphoteric which means their solubility differs and reach minimum values at certain level of pH values, and thus; the process is pH sensitive like electrodeposition, and pH can be raised by using some chemicals, such as NaOH, Ca(OH)₂.

Cementation is a process which also uses the redox potential of the metals for separation step. The main difference from electrowinning is practising the process without voltage. It is mainly work with the same logic with ion exchange units, but here the solution ions come into contact with a metallic surface which reduces them while oxidising its own metals, and system can be applied in different forms by changing temperature, and pH constantly. This process is also pH sensitive in some cases, and

mostly works on more electronegative ions in the solution and electronegative ions on metal surface, Fig.3 (see appendix) shows an example of cementation for metal removal in zinc electrowinning circuits ^[10].

Along with presented hydrometallurgical methods, there is also two other technics, called pyrometallurgy and electrometallurgy have been used in metal recovery. Pyrometallurgy basically is known as one of the high temperature practices on metal ores ^[3]. In the late 1950s INCO build a semi-commercial plant, and this plan was practically working in existence of metal sulphides. Briefly, they was using pressured oxygen in order to eliminate sulphur content as SO₂, and managing controlled reduction of the oxides to form metallic nickel which was previously leached by ammonia (Fig.4, see appendix) ^[3]. However, whole process of the plant was ended due to large tonnage of SO₂ emission to the atmosphere ^[3]. There is also another pyrometallurgical process which is known as smelting in which heat is applied to metal oxides along with the existence of carbon and reducing agent, which works to release the oxygen, and the refined metal was obtained. However, carbon dioxide, one of the greenhouse gases, has been released in this process as drawback of the process as it seen in Fig.5 (see appendix), one of the examples of zinc recovery ^[3].

As a last method of these traditional recovery methods, electrometallurgy appeared as more recent approach. Basically, it uses molten salts which are suitable for metal oxides to form charged species due to interaction with polar fluids metal ions. In principle, temperature of salts has been increased to higher values, such as *ca.* 500 to 1000 °C, in which strong lattice energy of the salt constituents has been broken and forming a liquid with very high conductivity, and this high conductivity open the door of electrochemical processes of Li, Na, Ti and Al, which are normally inapplicable in aqueous media ^[2-11]. On the other hand, high temperature molten salts are quite reasonable to use in electrowinning due to their aprotic and ionic structure. They present an atmosphere with low viscosity, high conductivity and viscosity and most importantly wide potential windows range which make metal salts highly suitable in their atmosphere. In addition to this, molten salts same even higher solvating properties than the aqueous media while not showing detrimental properties, such as high brittle structure during the hydrogen evolution, which are observed in aqueous media. However, it is quite costly process due to protect the physical form of the salt as liquid by supplying high temperature constantly as well as causing material compatibilities.

In light of this, it is quite obvious that all the processes have various drawbacks. Although there are lots of alternative methods to gain metal from hydrometallurgical processes, mainly they are slow, and also water based which are relatively hard to clean and generally encountered of natural water beds,

and becomes a grooving danger. In the same way, pyrometallurgy releases sulphur and carbon based constituents to the nature along with CO₂ which are also very harmful in long term processes. At the last point, molten salts actually seem as an alternative method for all others, but the process cost extremely high, and stability can be also a problem for plant scale applications. It is obvious that industry is needed to discover scale-up systems with new technics in which metal separations should be easily controlled by tolerating impurities along with increased solubility and current efficiencies, working temperatures should be in the range of moderate values, and most importantly non-aqueous environment should take place of the water-based systems. In that way, it will be possible to decrease current pollution and maybe increase the recovery rate of nature along with cost decreases in total processes.

1.2 Classification of ionic liquids

1.2.1 Ionic Liquids

A recent way to surpass all these difficulties and gaining more features to increase the general efficiency on metal recovery processes has been discovered by using a group of liquids known as ionic liquids. Mainly, they have the similar properties with molten salts with a significant difference remaining in liquid form even below 100°C. They are first described in the first decades of 1900s^[12]. Then, the concept of ionic liquid became one of the most important focused fields for both academia and industry due to their changeable wide range of physical properties along with eco-friendly chemical features. There are lots of organic cations and anions that potentially ready to prepare ionic liquids, and obtain some tuneable physical and chemical properties. These significant properties actually come from molecular structure of these liquids. When a normal salt taken, it is obvious that large attractive forces between opposite ions lock them together, and thus; common well known salts are in the form of solid phase. When these salts are exposed certain amount of heat, attractive forces decreases, and salts become to melt, but heating is not the only case to obtain a liquid ionic salt. It is also possible to reduce ionic attractions, such as making them with bigger or anti-symmetric structures in order to present them as low melted salts or directly liquid in the room temperature. In these sorts of structures, expected ion packing is not in good order, anti-symmetric structures blocks symmetric order ion packing. In other words, it is possible to make salts less attractive by making them more complex in terms of molecular order, so they can invariably poses a high degree of asymmetry. One way of this practise is mixing basic salts in suitable conditions so as to obtain less attractive ionic liquids. In fact, many of them have melting points below room temperature, and they are actually special kind of

electrolytes which mainly contains positive and negative ions without any solvent as 100% salt that is not the same salt dissolved in aqueous medium.

Large variety of cations and anions has been used to prepare ionic liquids. However, the kinds of anions and cations for specifically metal application based ionic liquids are a small part of whole picture in current literature. However, it is possible to use ligands as anionic components in extremely high efficiencies than the aqueous media solutes, and thus; selectivity are accessible for target metal ions in the media of ionic liquids. There is a well-documented study shows that some ionic liquids, prepared with ligand based specific anion tails, release great selectivity capabilities for toxic heavy metals, such as Cd^{2+} and Hg^{2+} [13].

The most outstanding characteristic of ionic liquids is their immeasurable vapour pressure [14]. Due to fact that very low vapour pressure of ionic liquids, they are still liquid under high temperatures without any important loss of evaporation up to their thermal decomposition point along with no flammability problem, and they also do not contribute air pollution because of this low vapour pressure that does not allow breaking up of any significant amount of molecule groups from liquids, and this is important once the study work goes on toxic ones. For these reasons, they are referred as green solvents, and application on metal processing of these tuneable ionic liquids will possibly allow great reduction in total amount of hazardous releases to a nature along with improved extraction efficiency in biphasic processes. Although ionic liquids generally are recognized with their toxicity, there is no disconcerting environment related issues on metal processing for both reasons, which are very low vapour pressure properties of them, and thus; no uncontrolled release is possible to the nature, and specifically chosen ones on metal processing have lower toxicity, which includes functionalized imidazoles, lactams, amino acids and choline, and the choline is especially have applied on metal recovery processes.

There is different kind of ionic liquid descriptions by depending on the anion kinds, used Lewis or Bronsted acid complex. Even discrete anions, such as BF_4^- , NO_3^- are the only limitation in description of ionic liquids for some authors. However, this definition will not adequate due to uncovering of chloroaluminate systems along with eutectic systems. On the other hand, classification is also quite difficult due to complex anionic species formed, which are also dependent on other constituents of the system, in the structure of ionic liquids. The formula given below actually covers many of the ionic liquids description [15].



In addition to this, complex cations could also be formed using species such as cryptans or crown ethers;



Eutectic Mixture	Metal Salt (ZnCl ₂)	Metal Salt Hydrate (ZnCl ₂ ·CoCl ₂ ·6H ₂ O)	Organic Salt (Choline Chloride)	Hydrogen Bond Donor (Urea)
Type-I	I		I	
Type-II		I	I	
Type-III			I	I
Type-IV	I			I

Table 2: Table.2 shows the general view of the classification of ionic liquids [15].

1.2.2 Discrete Anion or Second Generation Ionic Liquids

Discrete anion based ionic liquids emerged by Wilkes and Zaworotko along with the production of 1-ethyl-3-methylimidazolium tetrafluoroborate and acetate. In the research of Abbott and co-workers^[2] about trend of preferred ionic liquids from 2000 to 2010 shows that second generation ionic liquids based on discrete anions, such as BF₄⁻ and PF₆⁻, are most dominate kind in the literature from the invention of these tuneable liquids (Fig.6-7 see appendix). Especially these two anions, BF₄⁻ and PF₆⁻, were preferred because of their wide potential window that makes them usable in many electrochemical processes. However, they were water sensitive, and yielding HF, which is also released in aluminium production, and accepted one of the most dangerous chemical for human bones. For this reason, alternative anions, such as [CF₃SO₃]⁻ and bis-trifluoromethanesulfonylimide [(CF₃SO₂)₂N]⁻ take their place recently^[2]. However, these molecules can cause also issues when the hydrolysis of fluorinated anions occurs due to characteristic of fluoride which acts as a strong ligand for many metals, and tend to change metal speciation seriously during the recovery process. Due to ionic liquid production are generally derived from a metathesis reaction of a halide salt with group 1 metal or ammonium/phosphorus salts, which are also produced from a quarterisation reaction between amine/phosphate with a halogenated alkyl chain, of the desired anion as well as acid base neutralization reactions, second generation ionic liquids can also be formed by quarterisation reaction. On the other hand, temperature should be kept low in order to protect the salt structure and the purification of the constituents should be protected due to low vapour pressure of these systems as well as the high viscosity which make quite harder the second process in the time of any impurity occurred.

Viscosity and melting points along with some other physical properties are another important consideration in the decision of desired ionic liquids. As it is declared in beginning in the part of selectivity importance of ionic liquids, some anions as ligands are given as an example from Visser and co-workers study on Hg^{+2} and Cd^{+2} removing. In the same way, they also confirmed that length of alkyl groups of the ionic liquids can also lead to adjust these ionic liquids for desired viscosity, hydrophobicity and melting points^[16-17]. In their particular study, they used imidazolium cations along with alkyl appendages in order to change viscosity by changing the length of alkyl and substituent positions, such as changing from C_2 to C_4 imidazolium ring position make ionic liquid in optimum fluidity level^[2]. Another issue that should be considered is the anion effect on ionic liquid system. Although it referred as the cation has main control on specification of ionic liquids^[18], anion is more dominate on control in liquid due to tendency for interaction Lewis acid metal solute. However, it is contribution rate and features in different conditions are hard do discover, and classify.

In principle, a suitable metal recovery can be achieved with ionic liquid as long as it has satisfactory dissolving abilities which generally manageable by large amount of anionic constituents which system supplies. Main idea behind the necessity of large amount of anionic constituents is because of creating more anionic media with metal solute phase in the reaction. Another important point is the conductivity which becomes extremely important in metal processes. Although it is supposed that conductivity of medium is directly related with charge carriers, it is not enough to explain some situations, and so mobility of the ions are considered again. There is a reliable research was done by Abbott and co-workers on this phenomenon^[19]. They presented the data of four ionic liquids for viscosity and conductivity at first in order to get relation between them as it shown in graph.1 and graph.2 respectively^[19].

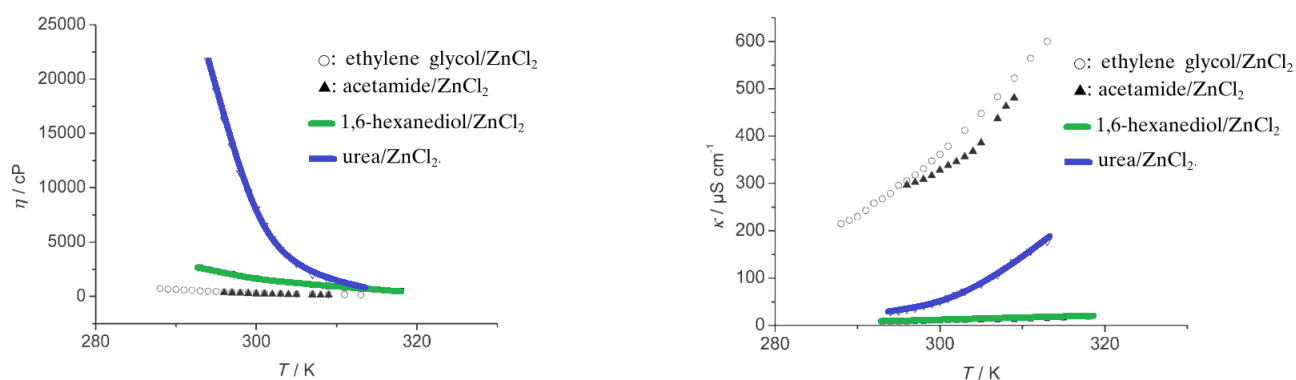

Graph 1 (viscosity), / Graph 2 (Surface Tension); Viscosities of a series of eutectic donor/ZnCl₂ liquids as a function of temperature / Plot of conductivity as a function of temperature for the donor/ZnCl₂ systems^[19].

At first glance, the conductivity can be evaluated by looking the viscosity by depending on mobility concept, and it can be declared that urea conductivity would be quite low than all of them with following of hexanediol, and ethylene and acetamide would possibly give the same results with highest values. Then, the group measured conductivity, and obtained some interesting results which was required them to spend more time to explain the phenomena. According to the conductivity graph; urea was more conductive than the hexanediol which was not expected by just depending on the viscosity. For this reason, it was explained with lower degree of ion dissociation of hexanediol. However, it is not only the case due to contribution of surface tension;

$$4\pi\langle r^2 \rangle = 3.5 \frac{kT}{\gamma} \quad \text{Y: surface tension, k: Boltzmann constant}$$

Surface tension requires the consideration of hole size of the whole structure of the ionic liquid in which the vacancies are available only for the small part of the ion among many, and this decide the motion of ions, and so; conductivity. Consequently, it can be referred that another important consideration in the decision of correct ionic liquid can be altered by depending on applications, e.g., electrowinning required high conductivity, and the metal used ^[19].

1.2.3 Deep Eutectic Solvents

Although it was called as just ionic liquid when it is discovered by Hurley and Wier in 1951, the description eutectic or deep eutectic actually was more suitable for the ionic liquid used for aluminium electrodeposition as a spark point of literature on electrodeposition. Hurley and Wier used N-ethylpyridinium bromide : 2AlCl₃ at 20°C. Then, AlCl₃ : 1-ethyl-3-methyl-imidazolium room temperature ionic liquid in the range of 33 and 67 mol% AlCl₃ was developed by Wilkes. Although first generation ionic liquid classification, for a wide variety of liquid salts term, is still common, first generation ionic liquids are very viscous than the ionic liquids and its derivatives that Wilkes discovered. Chloroaluminate systems can be suitable to call them as first generation along with the systems their anions have been formed by Lewis acid or Base.

Table.3 expands the classification information of ionic liquids given above paragraphs can be expanded with more information for the description of DES and along with other systems;

Constituents	Y	M	Z
1	MCl _x	Zn, Sn, Fe, Al, Ge, Ga	ROH, RCOOH, RCONH ₂
2	MCl _x .yH ₂ O	Cr, Co, Cu, Ni, Fe	
3	RZ		
4	MCl _x .yH ₂ O		

Table 3: Constituents of ionic liquids for wider description.

DES systems can be described with a general formula as $\text{Cat}^+\text{X}^-z\text{Y}$. The Cat^+ here can be a derivative of ammonium, sulphonium or phosphonium cation with a halide ion referred as X^- . The first generation eutectics, $\text{Cat}^+\text{X}^-z^{(1)}\text{Y}^{(1)}\text{M}^{(1)}$, involves metal halides in which they can be bond to organic ions strongly. The second generation eutectics, $\text{Cat}^+\text{X}^-z^{(1)}\text{Y}^{(2)}\text{M}^{(2)}$, involves hydrated form of different metal halides in which strong bond can be occurred between halide and organic. Third generation eutectics, $\text{Cat}^+\text{X}^-z^{(1)}\text{Y}^{(3)}\text{M}^{(2)}$, have hydrogen bonding groups which brings weaker bonds with respect to organic ones. The last one series of ionic liquids is known as fourth generation, $\text{Cat}^+\text{X}^-z^{(1)}\text{Y}^{(4)}\text{M}^{(2)}$, it uses metal chloride with hydrogen bond donor, and do not use an organic cation.

In the process of metal extraction, one of the point which are avoided is to have other metals, which are not intended to have normally, dissolved in the systems, and thus; eutectics were not use in a wide variety applications. However, Abbott and co-workers developed some metal containing eutectics by changing Lewis acid in the system with a Bronsted acid, and these eutectics can be prepared a quaternary ammonium halide and a hydrogen bond donor such as alcohols, amides or carboxylic acids. These eutectics showed high solubilities of metals, and they are also water insensitive although they are miscible with water. These eutectics were already tested in success on large scale in 2009 by Abbott.

1.3 Metal Processing with Ionic Liquids

Metal extraction is generally more common and preferred in metal processing by using ionic liquids rather than digestion. The main reason for this is availability of large scale application, but there are possible loses losses along with mutual solubility with water in this area. Physical loses in the process of digestion is large, and thus; only valuable metals can be extracted by this method in the choice of second generation ionic liquids. However, viscosity and cost make them applicable on small scale applications rather than large scale. It is also advantageous using small amount of ionic liquids to get the same efficiency with large amount of dilute liquid did ^[2].

1.3.1 Digestion of Metals

Metal digestion systems in the history did not have a mile stone evolution up to ionic liquids. Oxidising processes of metals from their elemental states are generally followed the traditional

methods in aqueous atmosphere by using some acids, sulphuric acid, nitric acid or the mixture of acids famous as aqua regia ^[21]. The consideration of choosing or developing an ionic liquid should be done carefully due to the possibility of decomposition which is not applicable for these systems. Whitehead and co-workers worked on this subject, and used 1-butyl-3-methyl-imidazolium hydrogen sulphate, iron (III) sulphide as oxidiser along with thiourea as a complexing agent. There are two aspects of this study besides the results they received. The ionic liquid can possibly be recycled, and it also was effective in terms of selectivity on different metal ores, Cu, Zn, Pb, Fe, along with its target metal gold, which released very reasonable results with high yields of gold, >85% and silver, >60%, although it was relatively slow with respect to aqueous media. However, it is also expanded later with new tries, such as changing the amount of sulphide or adding water, and the results were also improved by exceeding 85% gold, and 60% silver, and which gave better results than aqueous media in overall ^[20-21]. A recent study has been done, but not published yet by Abbott and co-workers on dissolution of a range of metals by using I₂/I⁻ ^[22]. They discovered that I₂/I⁻ redox potential was more positive than many common metals, and allowed to use it in even gold recovery or gold oxidation processes. Additionally, the test on electrocatalytic dissolution of copper and zinc showed that copper can also be separated quantitatively by electrodeposition.

1.3.2 Extraction

Traditional method on metal extraction is generally depended on using an immiscible organic solvent with a complexing agent to extract the metal in the aqueous media. In the similar way, along with the discovery of water immiscible ionic liquids, studies intended to use these ionic liquids in biphasic system to extract the metal, but this was not a simple replacement and required understanding of usable ligands with various tries to see the effectiveness ^[2]. Although several groups have focused on uranium processing processes, majority of the study was focused on imidazolium cations along with salts ^[2]. It is first found by Rogers *et al.* that ionic liquids with discrete anions can be used in biphasic systems which have similar partition coefficients with molecular biphasic systems. There is lots of study which focused on metal extraction with ionic liquids, and these systems are well classified in Abbott and co-workers study. They separated the studies into three different categories; complexing metal ions by using classical or neutral ligands, selective extraction of metals by depending mostly on anion interaction, and using task specific ionic liquids to extract the target metals ^[2]. The table 4^[2] shows the selected neutral ligands with ionic liquids which are used biphasic metal extraction studies.

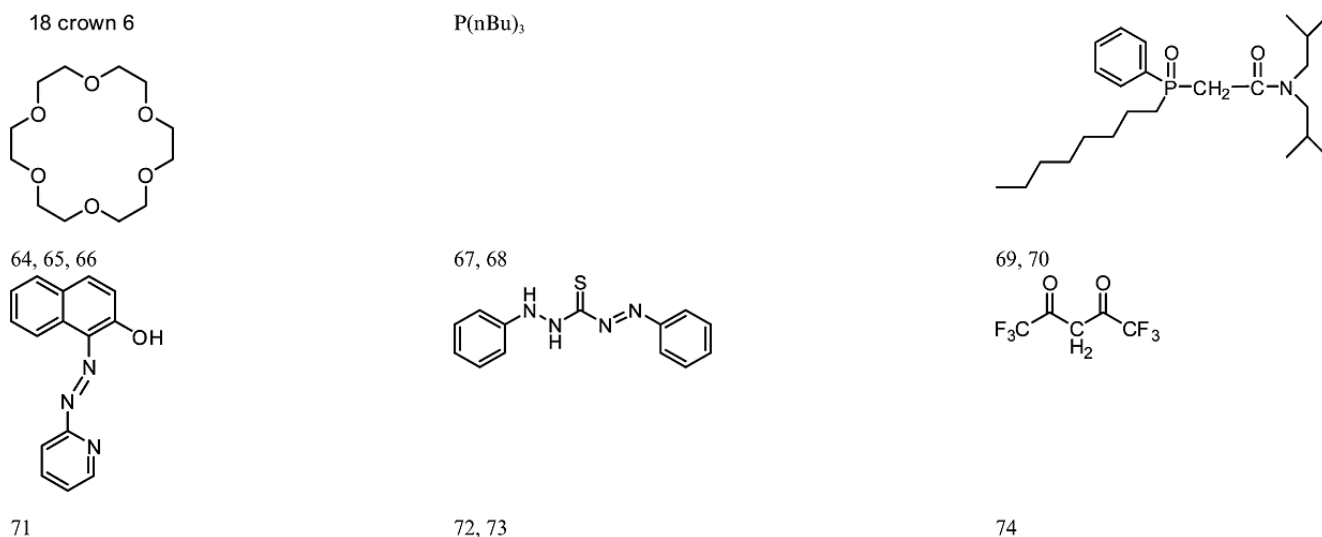

Figure 4: Commonly used ligands in biphasic extraction ^[2].

The feasibility of the process is hidden in the mechanism of the metal extraction process. The conditions of the extraction should be carefully considered in order to avoid any undesired leaching of ionic liquid or one of components of it which prevents the extraction process. In the realm of charged species transfer, it should be done in two ways due to higher solubility of the charged species in ionic liquids. The first method is the transfer of the metal ion to aqueous layer by having opposite charge carrier in aqueous side or using the same charged kind with the species in the ionic liquid and transferring it to the aqueous media. The mechanism of the metal transfer in ionic liquids and non-aqueous solvents were found different in various studies. One satisfying example came from Jensen and Dietz studies ^[23-24], 18 crown 6 were used as ligand, two axial nitrate ligands bind to metal centre as a result with neutral strontium complex. In the ionic liquid use, C₅mim Tf₂N. axial water ligands formed in cationic strontium complex transferring ^[2]. Dietz and co-workers also studied on sodium ions by dividing sections them between HNO₃ and C₅mim Tf₂N. The result was quite complex mechanisms can include up to three subsections; neutral, anionic and cationic transfer and further study was required to control pH of aqueous system along with cation hydrophobicity ^[2] in the system. In another study butyl-3-methylimidazolium nonafluorobutanesulfonate was used by Kozonoi and Ikeda for the extraction of various metals Li⁺, Na⁺, Cs⁺, Ca²⁺, Sr²⁺ and La³⁺. It showed that highly fluorinated anion was extremely hydrophobic which was possibly referred that cation exchange between two phases was due to metal ion transfer in the system. In a recent development of Liu *et al*, extraction of rare earth metals was studied with high extraction coefficients by using binary mixture of imidazolium and phosphonium ionic liquids as supporter on silica particles. The properties of the system has started to

show some similarities with ion exchange resins, such as high interfacial surface area, and they are also easy to apply modification due to depending on just the physical interaction between ionic liquid and support ^[2]. In these sorts of extraction systems, there is an important point which was emphasized by Dietz by showing the efficiency decrease in the use of neutral ligands which can be an issue due to mutual solubility capabilities of these substances even some ionic liquids shows immiscibility with water.

1.3.3 Electrowinning and reduction

A rectifier and a reaction chamber, which are houses of anodes and cathodes respectively, are main units to set up an electrowinning unit. In commercial systems, a set of cathodes and anodes are placed in reaction chamber along with the electrolyte. When potential difference applied, metal ions start to reduce onto cathode. Electrowinning has advantageous respectively the other methods in which elemental metal is recovered rather than a metal bearing solution. It is generally quite easy to recover and easy to use and control with one or two species metal containing systems. However, there is a very limited job done on recovery of complex mixtures of metal. Although electrochemistry of numerous metal salts have been studied with a wide variety of ionic liquids, there is still lack of consistency and understanding of reference potentials, speciation, electrode materials and temperatures which are the intersections of points make understanding and comparison difficult ^[2]. Electrowinning have been used extensively for years to extract metals, and thus; the importance of potential windows is well known. The best side of ionic liquids is the capability of high potential windows in some ionic liquids, such as [C₄mim][PF₆] 4.15V at Pt electrode or [BMP][Tf₂N] 5.5V at glassy carbon electrode, and it is also familiar that potential windows should be carefully considered in terms of hydrogen evolution which cause brittle structure, and some hazardous results. Additionally, Al, Mg, Ge and Si, low redox potential group, can be electrodeposit with ionic liquids which is not possible with aqueous media. In complex mixture of metal, electrodeposition is applicable as long as redox potential differences of species are large enough. The recent study of Abbott and co-workers gave an interesting behaviour of ionic liquids. They showed that metals salts behaviour in some ionic liquids is like ideal solutions in which redox potentials can be predicted as a function of concentration without activity coefficient contribution as shown below;

Chemical potential for an ideal solution: $\mu_A = \mu_A^\ominus + RT \ln[A]$

On the other hand, if the solution behaves non-ideal behaviour: $\mu_A = \mu_A^\ominus + RT \ln a_A$

$$a_a = \gamma_A \cdot [A], \quad \gamma_A \text{ is activity coefficient.}$$

This Nernstian behaviour was consistent up to 1 mol kg^{-1} . Hydrogen electrode was also involved in their study, and showed the Nernstian behaviour in which equilibrium electrode potential obeys the Nernst equation when the concentration/activity of a species taking in the account with reaction changes of the electrode. As it is known, it is possible to shift the redox potential of the liquid by using appropriate ligand in the formula. In the same way, it is possible the same effect in ionic liquids along with likely many metal-anionic complexes as unknown species with important effects on the system.

There are various issues to apply ionic liquids widely and without any problem in electrowinning processes. Counter-electrode reaction can be shown as one of it causes hydrogen evolution at the anode. There is also another consideration which is to protect the structure of ionic liquid from possible decompositions. There are some suggestions by Abbott and co-workers, such as using soluble metal anode, but can cause gas evolution, another solution can be use of electrocatalyst to oxidise metallic substrates and collect the metal at the cathode, all can be evaluated and applied by altering the conditions by depending on used ionic liquid ^[2].

1.3.4 Cementation

It is one of the alternatives to the electrodeposition, and uses more reactive metals as powder, and joined the metal containing solution. Basically, the metal in solution has been deposited onto reactive metal in the oxidation process. It is not suitable to use in acidic matrix due to hydrogen evolution as side reaction. Ionic liquids have been used to recover the lead from dust of electric arc furnaces. The main advantage of ionic liquids over the traditional aqueous solutions is mainly efficiency extraction of the metal from the solution. Although cementation works well, it can be quite slow in some applications because it uses the potential difference of the metals, and this drives the whole reaction without any external source of electricity, or other effective resources like electrowinning.

1.4 Photo-reduction with Different Light Sources

In the basic description of Photoreduction, reduction reactions induced by light in which one or more electrons joined to photo excited species or it occurs as photochemical hydrogenation of a substance in which the substrate is not electronically excited are also known as photo initiated reductions.

There are various studies on photo-reduction since it is one of the environmental and cost efficient methods. Photo-reduction has been widely studied in both inorganic and organic chemistry, especially practised with semiconductor materials (TiO_2 , ZnO , CdS , and WO_3) which have been show as appropriate light mediators for production of chemical fuels along with photo-chemical degradation of a few environmental contaminants^[1]. One of the advantages of semiconductors comes from their ability to generate electron/hole pairs when band-gap irradiation occurs, and these electron/hole pairs can be exploited in the various redox based processes. In the literature, there are lots of examples of these exploitations used in reduction of metals, especially noble ones. In 1980s, scientists studied on selective metal recovery, such as gold, platinum, palladium, rhodium, and silver, as well as other coinage metals which can be taken out from industrial wastes. In these semiconductor based systems, the metal has been photoreduced as deposition on semiconductor particles which could be separated from the slurry with centrifugation along with dissolution of the metal in HCL/HNO_3 as later process. These systems was required certain pH, some acid solvents along with scavengers like CH_3OH works as valance band hole (h_{vb}^+) as well ^[2].

There are also another examples have been studied under photoreduction in both water, and chloro aqua media, and determining the speciation is generally hardest and most difficult part in which photoreduction can be stop or completed very fast depending on the species metal bonded. The table below shows the link of photoreduction oxidation and interval stages ^[3].

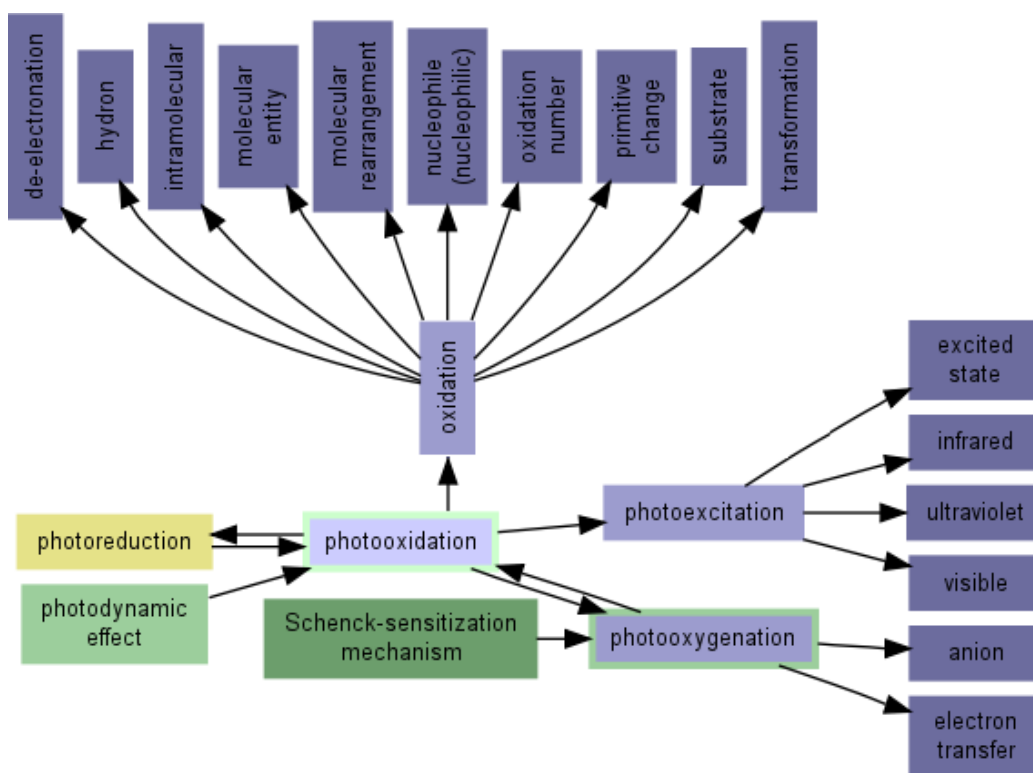
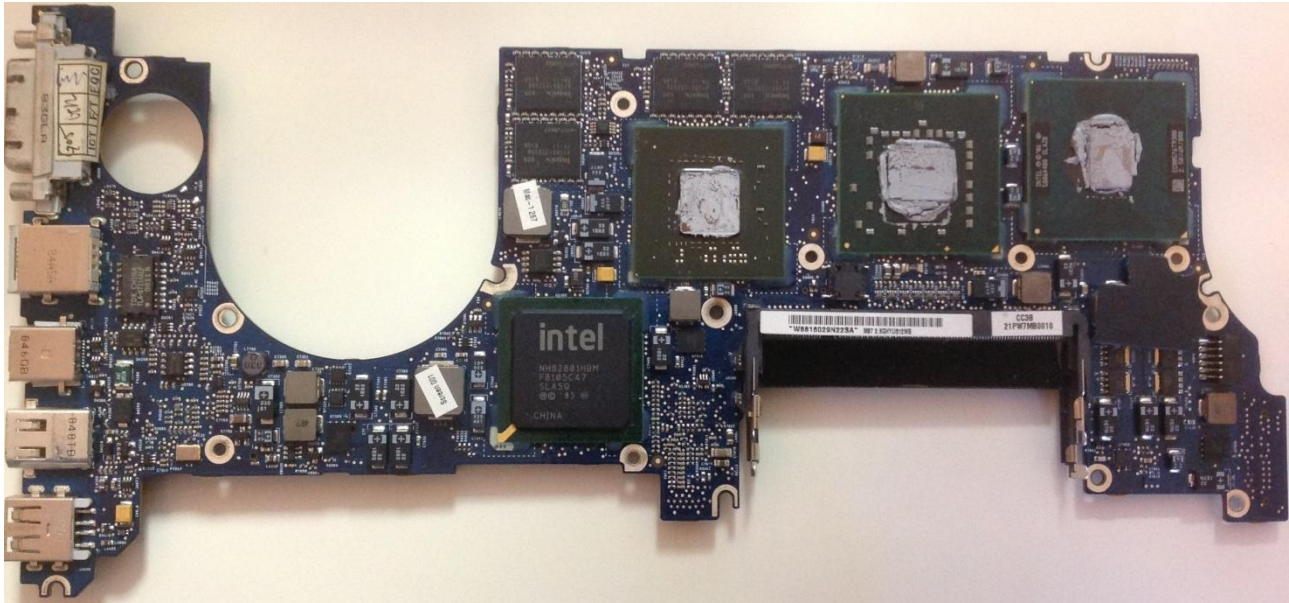

Figure 5 Interactive link map

1.5 Recycling of Printed Circuit Boards

There is a couple of whole review on this issue. However, it is mostly has spoken out by media in order to attract attention of both industry and academia. According to data of the media news, 320 tons of gold has been used throughout the worldwide in the production of PCBs which are placed in various kinds of electronic devices. It is estimated that the total value of recyclable gold is £10 billion in each year, but 15% can be recovered annually. To give an idea what printed circuit boards look like the picture below was taken from a computer;



Picture 1: Printer circuit board picture of laptop taken by Salih Cihangir

The thing that makes printed circuit board valuable is not just gold. There are numerous precious metals have been used in PCBs as it seen from table 4;

Electronic waste	Weight (%)					Weight (ppm)		
	Fe	Cu	Al	Pb	Ni	Ag	Au	Pd
TV board scrap	28	10	10	1.0	0.3	280	20	10
PC board scrap	7	20	5	1.5	1	1000	250	110
Mobile phone scrap	5	13	1	0.3	0.1	1380	350	210
Portable audio scrap	23	21	1	0.14	0.03	150	10	4
DVD player scrap	62	5	2	0.3	0.05	115	15	4
Calculator scrap	4	3	5	0.1	0.5	260	50	5
PC mainboard scrap	4.5	14.3	2.8	2.2	1.1	639	566	124
Printed circuit boards scrap	12	10	7	1.2	0.85	280	110	–
TV scrap (CRTs removed)	–	3.4	1.2	0.2	0.038	20	<10	<10
Electronic scrap	8.3	8.5	0.71	3.15	2.0	29	12	–
PC scrap	20	7	14	6	0.85	189	16	3
Typical electronic scrap	8	20	2	2	2	2000	1000	50
E-scrap sample 1	37.4	18.2	19	1.6	–	6	12	–
E-scrap sample 2	27.3	16.4	11.0	1.4	–	210	150	20
Printed circuit boards	5.3	26.8	1.9	–	0.47	3300	80	–
E-scrap (1972 sample)	26.2	18.6	–	–	–	1800	220	30
E-waste mixture	36	4.1	4.9	0.29	1.0	–	–	–

Table 4: Some additional metals given PCBs included ^[26].

In addition to this, PCBs recovery has been done for years by various companies. However, most of them use aqueous based, mainly acid based solvents to dissolve and recover the metals. While the metals are recovered, environment becomes unrecoverable day by day. For this reason, it is not wrong

to say that novel methods are required to recover these metals as green solutions in order to protect the environment.

1.6 Project Objectives

Electrowinning, cementation and precipitation will mainly be used to select numerous of metals which includes Au, Ag, Cu, Pt, Pd in current plan, but can be widened depending on the sources. Solution species will be identified, quantification of dissolution rates and electrochemistry of metals in solution will be studied. The project will also work on possibility of scale-up processes. One of the main issues identified above is the subsequent separation of metal ions from the ionic liquids once they have dissolved. One method that we have already identified as being suitable is electro-winning. To determine the overall suitability of this technique to the soluble metal species in a matrix the redox potentials for all of the metals. Electrochemical studies will be carried out for all of the metals extracted and predictive models will be developed to find the relationship between the reduction potential and the hydrogen bond donor in the ionic liquid. This will help with electrowinning methodologies and supply information on metal oxidation states. Additionally, different light sources and X-ray will be used along with different reducing agents soluble in chosen DES systems to determine whether light carries similar behaviours with other solvent systems which used to reduce silver nitrate or other valuable metal mixtures by hitting photon on halide metal shell order.

1.6.1 Project Outputs

- New reducing agents will be added to the library of solubility data of metal-DESmixtures
- Preliminary data on the efficiency of the scale up process
- Different light sources
- X-ray in Photoreduction
- Redox potential shifts
- Identification of metal speciation
- Electrochemical properties of metal salts
- Generic protocols for metal separation from simple and complex mixtures
- Case studies for successful separation protocols

2.0 Experimental

2.1 Equipment and preparation

2.1.1 Preparation of DES samples

In this study, three different deep eutectic solvents were used which are Ethaline 200, Reline and Oxaline. Majority of experiments mainly were completed with Ethaline 200, and sources of all chemical compounds are put in table below.

Compound Name	Obtained From	Purity
Choline chloride	Sigma-Aldrich	≥98.0
Urea	Sigma-Aldrich	98%
Ethylene glycol	Sigma-Aldrich	≥99.0%
Oxalic acid dihydrate	Fisher	98%
Gold(I) chloride	Aldrich	99.90%
Silver chloride	Sigma-Aldrich	99%
Copper(I) chloride	Sigma-Aldrich	≥90.0%
Iodine	Fisher	98%
Sodium thiosulfate pentahydrate	Sigma-Aldrich	≥99.5%
Catechol	Sigma-Aldrich	≥99.0%
Hydroquinone	Sigma-Aldrich	≥99.0%
Citric acid	Sigma-Aldrich	≥99.5%
Trisodium citrate dihydrate	Sigma-Aldrich	≥99.0%
Lithium bromide	Sigma-Aldrich	≥99.0%

Table 5 All used chemical throughout the project with source and purity rate

In the preparation of Ethaline 200, choline chloride ($(\text{CH}_3)_3\text{NCH}_2\text{CH}_2\text{OH}_9\text{Cl}$) and ethylene glycol ($\text{C}_2\text{H}_4(\text{OH})_2$) were put in a vessel as 1:2 molar ratio, and heated 70°C up to the homogenous solution form was obtained. Then, the solvents were allowed to cool at room temperature to *ca.* 25°C before any further experiments were performed.

In the preparation of reline, Urea ($(\text{NH}_2)_2\text{CO}$) and Choline chloride, at 2:1 ratio, were mixed at room temperature and left in oven over night, and then continued to stirrer at 60°C until homogenous solution was observed.

Oxaline preparation is basically is the substitution of ethylene glycol with oxalic acid. In brief, oxalic acid dihydrate $\text{C}_2\text{H}_2\text{O}_4 \cdot 2\text{H}_2\text{O}$ was mixed with choline chloride, and left in oven over night, and then continued to stirrer up to homogenous solution was observed.

As it is known, there is a hydrogen bond donor and hydrogen bond acceptor in ionic liquids and this hydrogen bond brings specific properties, such as non-volatility along with irregular ion cluster formation in the solution. In the below table, formulation and classification is declared for our compounds in the DES part.

Deep Eutectic Solvent	Hydrogen Bond Donor	Hydrogen Bond Acceptor	Ratio
Ethaline 200	 ethylene glycol	 chlorocholine chloride	2:1
Reline	 urea	 chlorocholine chloride	2:1
Oxaline	 oxalic acid	 chlorocholine chloride	1:1

Table 6 Classification of hydrogen bond donors and acceptors in used DES of the project

2.1.2 Preparation of silver and gold ion containing eutectics

Each silver ion containing DES was prepared as 50ml volume 100mM which contains 0.7166 gram AgCl.

Dissolution of silver was took around 4 hours by avoiding direct light in the bench at around 70 °C temperature with continuous stirring. Then, prepared 100mM AgCl in Ethaline 200 was put in closed, light proof oven.

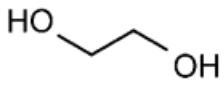
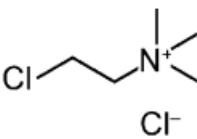
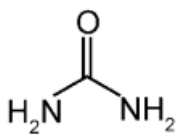
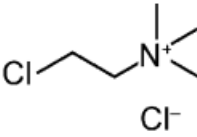
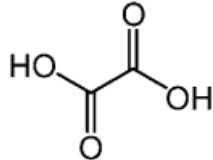
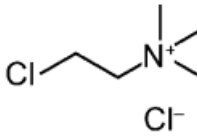
Gold ion containing solution was taken as prepared from previous study around 6 ml, and amount of gold calculated in every 2 ml (volume of mass tube that experiments were carried out) for the purpose of efficiency calculations in which recovered pure gold mass was compared with total mass of pure gold in 2ml.

When a basic calculation has been done regarding to 130mM AuCl mixture in each 2ml mass tube, total amount of gold calculated as **0.0512 gram**.

2.1.3 Preparation of reducing agents

A couple of reducing agent dissolution tests have been done for Ethaline 200, reline and oxaline separately. Reducing agents mainly have been chosen by depending on previous studies which will be explained widely in the part of dissolution of photo-induced reducing agents. In general, Ethaline 200 dissolve the most of them, and oxaline also worked on some along with reline, but the oxaline turned into extremely viscous solution after reducing agent addition, and even did not flow from sample tube in some studies. Furthermore, oxaline produces lots of bubbles, and make it hard to realize or analyse whether the reducing agent dissolved or not in the solution. Reline also worked on a few of reducing agents like Ethaline 200, but dissolution generally took hours more than 180 minutes in some. The only deep eutectic solvents in terms of stability for among three is Ethaline 200 in which majority of the physical properties did not change, such as colour, viscosity.

The table below summarizes of studied reducing agents, some is not in the list of Ethaline 200 which did not dissolve at all even partially.

DES + 0.1M AgCl	Trisodium citrate dihydrate	LiBr	Citric Acid	Hydrazine hydrate	Hydrazine dihydrochloride
Ethaline 200	X	X	X	X	X
Reline	X	X	X		
Oxaline	X	X	X		

Table 7 Studied mixtures with deep eutectic solvents

2.2 Experimental techniques used

2.2.1 XRF/UV/Laser

XRF used for the purpose of source of X-ray in photoreduction of mainly silver and gold containing samples. Normally, it is used to obtain X-ray emission from a sample. This emission(s) is produced when beam of charged high energy particles hit and excites a core electron and ejects from target atom. When ejection occurs, atoms turns to unstable condition due to hole on the shell, and thus; it is filled by

an electron from outer shell for the purpose of re-stabilization, and this filling processes are known as relaxation of an electron which creates an X-ray emission with special characteristics of this specific transition for a particular element. Basically, creating a core hole is the main condition of emitting X-ray, and a core hole can be created in two ways ^[27];

- 1) Material exposed to fast electron bombardment by (e.g. electron microscope, X-ray tube)
- 2) Ejection photo electrons from core orbitals by high energy X-rays (e.g. X-ray fluorescence spectroscopy) ^[27].

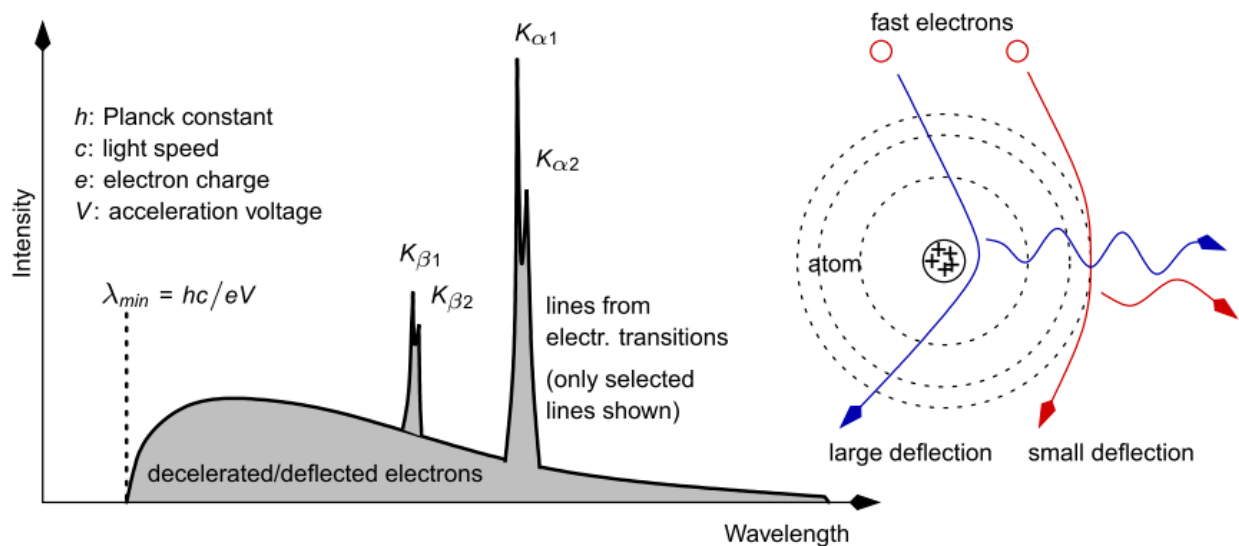

Figure 6 Illustration of large and small deflection ^[27]

After a target material hit by fast electrons, core holes created by some of these striking fast electrons along with creation of emission lines. The energy peak of an emission is directly related with intensity of created momentum of these electrons (Figure.1). Shortly, large deflection comes from emission of large photons (high energy, short wavelength).

There are various applications of exposition of electron beams to the sample, such as SEM, AES, EELS, EDX with different level of energy emissions.

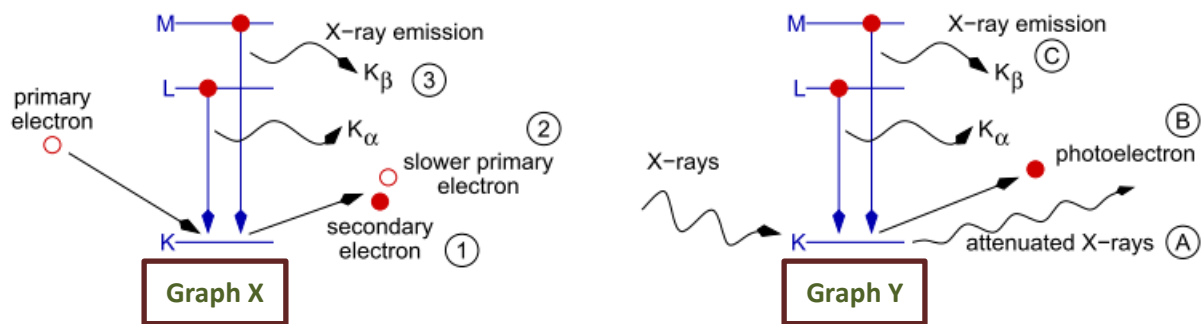

Figure 7 Graph X: Sample exposed to electron beam,

Graph Y: Sample exposed to X-ray beam ^[27]

1. Scanning electron microscopy (SEM) and Auger electron microscopy (AES)
2. Scanning electron microscopy (SEM) and Electron energy loss spectroscopy (EELS)
3. X-ray tube and energy-dispersive X-ray spectroscopy (EDX)
 - A. X-ray absorption spectroscopy (XAS, inelastic) and X-ray diffraction (XRD, elastic)
 - B. X-ray photoelectron spectroscopy (XPS)
 - C. X-ray fluorescence spectroscopy (XRF) also known as XAS

In our experiments we used XRF machine for the purpose of X-ray explosion not for purpose of analysing samples. The machine is Axios^{Max}-Advanced designed and configured for high speed XRF analysis. The system is equipped with 4.0kW operating power, 60kV excitation, 160mA tube current and a range of other features which makes it the fastest sequential WD-XRF spectrometer available (**for details see Appendix 1.1**) ^[28].

2.2.2 XRF/UV/Laser

Ultraviolet visible spectrometer was used for two purposes in our experiment as light source for photoreduction in kinetic mode with different wavelengths for different time scales, and used as analysing for prepared samples.

As light source we used in kinetic mode in which a chosen wavelength (e.g. 300nm) exposed to the sample in quartz tube in continuous spectrum for various times. Used device is The Shimadzu UV-1601 UV-VIS spectrometer is used for transmission spectroscopy in the range from 190 nm to 1100 nm. There are two lamps used: a tungsten lamp that covers the region from 350 nm to 1100 nm, and a deuterium lamp that covers the region from 190 nm to 350 nm. The instrument can be used in a scanning spectrum mode, a kinetics mode, and a quantitative analysis mode. Data acquisition and processing is controlled through the Shimadzu UV-Probe software (**machine picture Appendix 1.2**).

2.2.3 XRF/UV/Laser

In our study, two kinds of lasers were also used for the purpose of silver reduction. A basic less powerful laser $630\text{nm} \pm 10$ with maximum 5mW red-shift laser used as starting point (**see Appendix 1.3 for demonstration**). Then, more powerful 1064nm pulse laser system was set up in laser lab, and used to expose to the samples for variable times. Thus, laser has been used for professional applications and require to safety instructions prior to use. It was used with laser goggles along with protective stainless still sheet for absorption of laser after pass from solution filled quartz. The brand of the laser is Minilite is Continuum's level Q-switched Nd:YAG laser, and it is used at 5Hz and at 16 mJ power. General specifications of the laser (see **Appendix 1.4**)^[29].

2.2.4 Analysis Techniques UV/SEM/EDX

Ultraviolet visible spectrometer was used for analysing purposes in which possible nanoparticle observation was aimed to detect by analysing samples before and after light expose. This transmission spectroscopy has a scan range of 190nm to 1100nm .

2.2.5 Analysis Techniques UV/SEM/EDX

The scanning electron microscope (SEM) is used for the purpose of mainly compositional information of purified gold containing samples on carbon sticky pads. SEM has an electron gun which produces a stream of monochromatic electrons, and there are magnetic apparatus to de-magnify the beam in order to focus on scanning beam comes from target part from sample.

In brief description, primary electron beams are sent to sample, these electrons hit sample atoms and release as slower primary electron or secondary electrons;

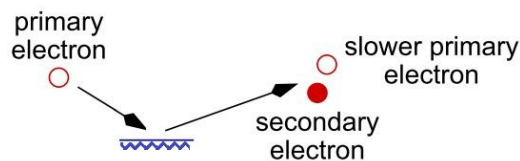

Figure 8 SEM - electron beam and release process

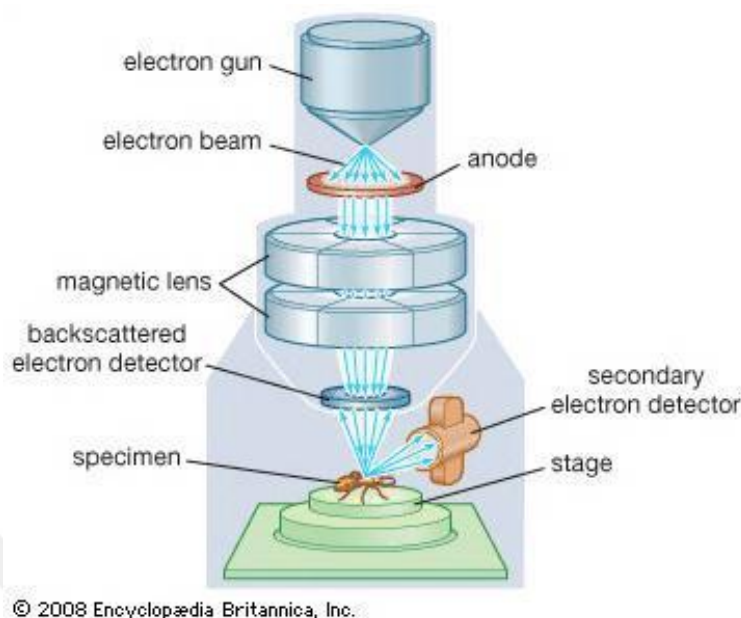

Figure 9 SEM with divided internal sections ^[30]

These emitted slower primary electrons or/and secondary electrons carries the required information and also are specific for each element in the nature. After theses released beams scanned, compositional information is also obtained from EDX analysis for target part of the sample. Samples prepared for SEM have to be conducting and electronically grounded to avoid accumulation of charge on the surface.

2.2.6 Purification

In the purification step, five different devices were used as centrifuge, ultrasonic cleaning unit, vortex mixer and oven. Purification step was applied to remove ionic liquid and other impurities around the gold particles in mainly Ethylene 200.

Centrifuge device was Centaur 2 and has the maximum limit of 4600 rpm with 2 swing-out rotors and 2 fixed angle rotors with a wide range of buckets and adaptors (**see Appendix 1.5 for more information**), and usually worked more than 5 times in each purified sample tube. Ultrasonic cleaning unit was Transsonic T460/H with 35 kHz maximum ultrasonic frequency supply, and mainly use to remove the very small gold particles from edge of both mass tube for original sample and each centrifuged plastic tube. In each intermittent section, vortex mixer was used to raise the precipitated small gold particles from tubes bottom. After all steps, sample was left in oven over night.

2.2.7 Cyclic Voltammetry

Measurements of current changes within certain potential windows were done for several samples. In cyclic voltammetry, measured unit is current which develops in electrochemical cell under conditions where voltage is in excess of that predicted by the Nernst equation. There are three electrodes in the system as working electrode (2mm diameter Platinum), reference electrode (Silver wire) and counter electrode (Platinum flag electrode). In principle, potential of working electrode is measured against reference electrode provides a constant potential, and resulting applied potential causes an excitation signal and declares the points where the voltage is sufficient enough to have caused an oxidation or reduction of an analyte. All electrodes were attached to the Fra2 μ AUTOLAB type3 potentiostat to control the potential and measured currents. The software used was GPES (v 4.9), the data was plotted as a measurement of current (A) versus applied voltage (V).

2.3 Dissolution of photo-induced reducing agents

The first point on this subject is to make clear the task of the reducing agents. In this study, silver chloride was aimed to recover with exposed light, such as UV, laser or bombardment with fast electrons, X-ray. In general, reducing agents work as electron acceptor or donator with the effect of photon or more powerful particle hits. Majority of the previous studies have used reducing agents along with added nanoparticles of target metal chosen for recovery. For instance, if the silver is the target metal of recovery, they added reducing agents which initiated the growing reaction of nanoparticles due to reduction of target metal ion on the surface of these nanoparticles. Briefly, metal species binds its own kind. In order to decide suitable reducing agents, variety of them has been decided to check in terms of solubility in our deep eutectic systems.

2.3.1 Sodium citrate tribasic dhydrate dissolution in eutectics

By depending on Munro and co-workers study, citrate or its derivatives wanted to be tried by expecting the increase the speed of recovery of silver ions on the nanoparticle surfaces after the initial reduction occurs. Solubility tests were started with 0.01 g reducing agent addition for each 4 ml DES.

Solubility at 100ml	Reducing Agent	T(°C)
Ethaline 200	Trisodium citrate dihydrate	70
Reline	"	60
Oxaline	"	65

Table 8 Trisodium citrate test conditions in three DES systems

2.3.2 Citric acid dissolution in eutectics

In the inspiration of the studies related nanoparticle growing with citrate and its derivatives, citric acid is also tried for the solubility properties in eutectics. Addition amount started with 0.02g up to 0.075g, and then; continued to addition process up to dissolution limit observed.

Solubility at 100ml	Reducing Agent	T(°C)
Ethaline 200	Citric Acid	65
Reline	"	60
Oxaline	"	65

Table 9 Studied citric acid amounts in three different DES

2.3.3 LiBr dissolution in eutectics

Different bromide salts were tried on three deep eutectic systems. The way of determination of the solubility of lithium bromide salts have been kept same with previous two compounds. Addition step was more complex in this agent due to quite different solubility in each of them. For this reason, LiBr was added from 0.01g to maximum 0.032g to the DESs.

Solubility at 100ml	Reducing Agent	T(°C)
Ethaline 200	LiBr	70
Reline	"	60
Oxaline	"	65

Table 10 Studied lithium bromide amounts in three different DES

2.4 Photo-induced reduction of silver and gold with different light sources

2.4.1 Ultraviolet light

Various light sources have been used to reduce the silver, and the first method tried is the ultraviolet light. Studied machine is the Shimadzu UV-1601 UV-VIS spectrometer is used for transmission spectroscopy in the range from 190 nm to 1100 nm as declared in section 2.2.1.

As it is known, standard UV machines has several modes, and one of them is called as kinetic mode in which continuous spectrum have been provided for chosen wavelength and time. In our study, we used kinetic mode of UV machine in order to reduce the silver. Although Mathieu (2003), and Munro (1995) used mainly laser as photon source^[31-32], UV was intended to try due to one study previously done by Courrol and co-workers^[33] in which the group used AgNO₃ rather than AgCl under different light sources 70-W, inner igniter, high-pressure sodium lamp (which produces virtually monochromatic light in the 589 nm wave-length), a 150-W xenon lamp, and an ultraviolet LED (390 nm), Nd:YAG

coherent laser pulses, at wavelength of 532 nm, 10ns and 10Hz, 15–200-mJ pulse energy. Courrol and co-workers observed particles formation and check this data with UV spectroscopy as declared figure below;

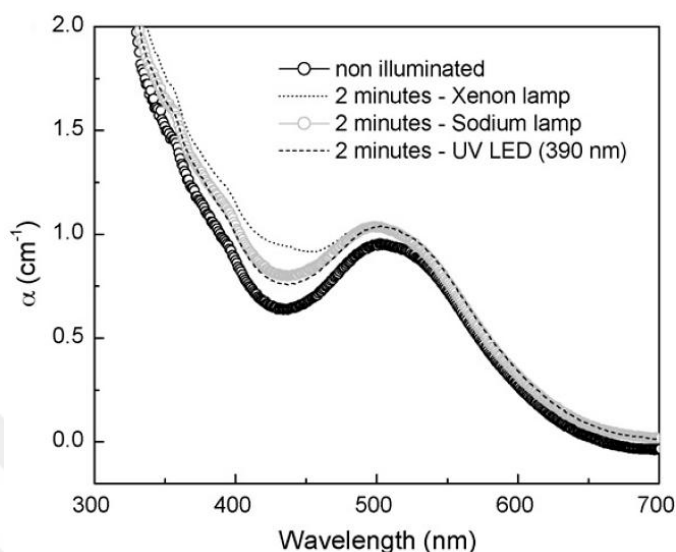

Figure 10 Changes in the absorption spectrum of a colloid solution caused by 2-min illumination with non-focused xenon light (XeNPs), sodium light (NaNPs) and UV LED (390 nm) (LEDNPs) ^[33]

UV was used in a certain order to detect the possible differences in different samples as follow;

- All samples were checked in UV spectrum mode from 190nm to 1100 nm against reference DES (ethaline 200, reline, oxaline).
- Samples was put in UV in kinetic mode and exposed to light as declared in table 10 and table 11 for certain time scales
- After UV exposition, all samples have been checked second time against reference sample, and the temperature was generally around 25°C.

Reference Sample	DES + 0.1M AgCl	Substances	UV(300nm)	UV(200nm)
Ethaline 200	Ethaline 200	LiBr	90 min	90min
"	"	LiBr	140 min	120min
"	"	LiBr	150min	160 min
"	"	Citric Acid	180 min	180min
"	"	Citric Acid	200 min	200 min
Reline	Reline	Citric Acid	200 min	180 min
"	"	Citric Acid	180 min	180 min
"	"	LiBr	180 min	150 min
"	"	LiBr	200 min	200 min

Table 10 Samples put in UV with one added reducing agent

Reference Sample	DES + 0.1M AgCl	Substances	Substances -2	UV(300nm)	UV(200nm)
Ethaline 200	Ethaline 200	LiBr	Citric Acid	140 min	120min
Reline	Reline	Citric Acid		-	-
"	"	LiBr	Citric Acid	180 min	150 min
"	"	LiBr	Citric Acid	200 min	200 min

Table 11 Samples put in UV with two added reducing agents

2.4.2 630nm laser light

In the same way with UV tests, basic laser around 630nm wavelength is also tried in our experiments (see **Appendix 1.3**), and the reason of this try is also comes from the study of Courrol and co-workers with various light sources ^[33].

The power of the 630nm laser was changing from time to time since it have not provided with continuous power source. However, it is expected that the wavelength of the laser was maintained around 630nm, and each sample tube was scanned intermittently with 2cm range as vertical position.

Reference Sample	DES + 0.1M AgCl	Substances	630nm Laser
Ethaline 200	Ethaline 200	LiBr	30 min
"	"	LiBr	60 min
"	"	LiBr	90 min
"	"	Citric Acid	30 min
"	"	Citric Acid	60 min
Reline	Reline	Citric Acid	90 min
"	"	Citric Acid	120 min
"	"	LiBr	60 min
"	"	LiBr	90 min

Table 12 The list of the chemical mixture exposed 630nm laser

2.4.3 1064nm 5Hz 16mJcm-2 Laser light

The idea of use of this powerful laser comes from another noted studies rather than Coureel and co-workers study. Alexander and co-workers worked on KCl solution and observe nucleation in the solution ^[34]. Their base was super saturated ultra-pure water. Solution was exposed 1064nm 7ns pulse laser with 5.8 mm diameter light area (see **Appendix 1.6**). Laser passed throughout to KCl solution. After laser expose, visible cumulative crystals were formed. In the same way, 1064 nm, 5Hz laser was used for various samples. All samples were put in quartz cuvettes and the laser light pass from sample as seen below picture for certain time scales, in some experiments laser was shifted vertically to scan everywhere.

Each sample tube was checked in the UV before the laser exposure, and rechecked after operation applied.

Reference Sample	DES + 0.1M AgCl	Substances	1064nm Pulse Laser
Ethaline 200	Ethaline 200	LiBr	210 min
"	"	Citric Acid	210 min
Reline	Reline	Citric Acid	210 min
"	"	LiBr	210 min

2.4.4 X-ray exposure

It can be called most powerful particle source in 2.4 part of experiment, study was jumped from photon size of bombardment to electron size of bombardment in the set of light exposure experiments. Previously, one of colleagues of mine study showed that X-ray can reduce the gold. The time of the study was not enough for further tests to get clearly visible results, and the declaration of power consumption and other quantitative parameters, such as recovered amount of gold. Besides, silver could not be investigated like gold. The X-ray machine was used is Axios^{Max}-Advanced that clearly explained with other properties in experiments techniques 2.2. Machine could be used once due to time and project plan.

Ethaline 200 was used as main DES with reducing agents as clear solutions for all (see Appendix 1.8). The procedure of the completed test with X-ray is below;

- Mass tube was used as sample tube and put in X-ray machine
- Each sample tube was prepared as 4 examples in order to try different power ranges in X-ray
- 4 sample mass tube were prepared as 16 sample tubes
- Each group with 4 mass tubes were exposed 4 different X-ray powers

Below tables shows the ingredients of the sample tubes along with exposure powers;

Tube Code	AgCl / mol ^{dm} ⁻³	AuCl mol/dm ⁻³	LiBr / g	Citric Acid / g
A1	0.1	-	0.032	-
A2	0.1	-	-	-
A3	0.1	-	-	0.075
A4	-	0.13	-	-

Table 13 Ingredients of the sample tubes

Four tubes in each set were coded from A1 to A4 in order to ease chose and read of data after X-ray exposure.

Set No	X-ray Power
1	30s / 30kV-20mA = 0.6 kW
2	30s / 60kV-50mA = 3.0 kW
3	300s / 30kV-20mA = 0.6 kW
4	300s / 60kV-50mA = 3.0 kW

Table 14 Exposure powers of each set (4 tubes)

Exposure times of X-ray were chosen as short 30 seconds and long 300 seconds. However, one of the latest study (published after X-ray part of experiment was completed) shows the time and power chosen by our group may actually be shorter for some metal halide groups. There are also noticeable similarities between their and our study, and all will be declared in the result and discussion parts with details.

2.5 Chemically reducing of silver to selectively remove from solution

It is aimed to check some possible reducing agents to practise chemical reduction in mixture in order to reduce silver from solution with assistance of electrochemistry. Mainly, three chemicals are determined to check potentials windows as alone, with silver only, with copper only, and silver and copper together. All experiments carried out in this section have been prepared as 10mM. Ethaline 200 is the only DES was aimed to check in this part of the experiment.

As starting point, it was aimed to see how does reference potential change when put target reducing agent in the DES. This set of tests has been performed with sodium thiosulfate pentahydrate, catechol and hydroquinone. Interesting results have been observed will be declared in section **3.0**.

Since Ethaline 200 will be used as solvent medium for all of reducing agents, it is potential window for no oxidation and reduction has been measured before starting to experiments.

Other interesting observation came from thiosulfate tests in which solutions shows some precipitations as seen pictures below in a short time. In the first a 20 second interaction of sodium thio sulphate with copper(I) chloride, which is originally yellowish in Ethaline, yellow colour of the solution turn into colourless form. Moreover, the solution produces black precipitation with the addition of the silver to the thiosulfate containing solution.

3.0 Results and discussion

This chapter will provide three sub categories as declared below, and will include all three sub sections of section 2.0 along with some discussions, and partial results of part of section 2.0. Later, overall result will be presented in section 4.0.

- Dissolution of photo-induced reducing agents
- Photo-induced reduction of silver and gold with different light sources
- Chemically reducing of silver to selectively remove from solution

3.1 Dissolution of photoinduced reducing agents

This section basically covers the results of the section 2.3, dissolution of photo-induced reducing agents. Intentionally, it is not aimed to explain the each dissolution of reducing agent separately in order to keep things more tidy and understandable.

As it declared in section 2.3, three different reducing agents, Sodium citrate tribasic dhydrate, Citric acid, LiBr, have been tested. In the following paragraphs, the solubility of the certain reducing agents will be presented along with reason of choose with provided references.

Although the aim of this study is not growing nanoparticles with reducing agents, some articles have been taken as reference point, for chosen reducing agents, due to applied mechanism in these systems which make us to believe the suitability of using them.

There are quite a lot studies on citrate and use of its derivatives in nanoparticle growing of silver metal. One of them comes from Munro and co-workers^[32]. In their study, two main experiments have been completed, citrate reduced silver, and borohydride reduced silver. Munro and co-workers shows a mechanism of citrate role on silver nanoparticles (see **Appendix 1.7**)

In the same way, Mathieu, Munro and co-workers shows the general mechanism along with the wavelength relation with reduction. They explain the importance of citrate molecules as key player in silver reduction in which 'Citrate acts as a capping ligand for the silver particles as well as photoreducing agent for the silver ion' (Mathieu, 2003). As it seen Munro and co-workers study, citrate has three carboxylic groups and two of them bind to the surface of silver nanoparticle, and the last carboxylic group stays alone as normal to the surface with negative charge which probably allows it to

make a colloid stabilization by electrostatic repulsion. The process of citrate placement on silver nanoparticle possibly comes from below process ^[32].

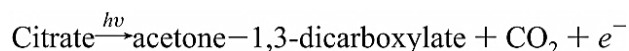

Another point is here the nucleophilic carboxyl groups in citrate which induces a fractional electron transfer when these groups adsorbed in the nanoparticle surfaces. Heglein and co-workers explain this situation as general for adsorbed molecules which induces a displacement of the metal Fermi level toward the more negative potentials ^[35]. Besides nanoparticles may play a role of electron storage and transfer medium which was already observed as a displacement of the Plasmon resonance after the electron injection inside the silver nanoparticles, in this way, increase the chemical reactivity on its surface, and so; ease reduction is possibly expectable on the surface of silver nanoparticles, and the possible reaction ^[2];

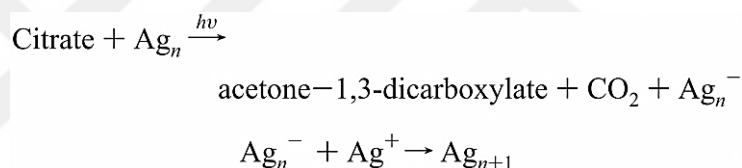

Equation 1 Possible reaction of citrate with silver nanoparticles under light exposure

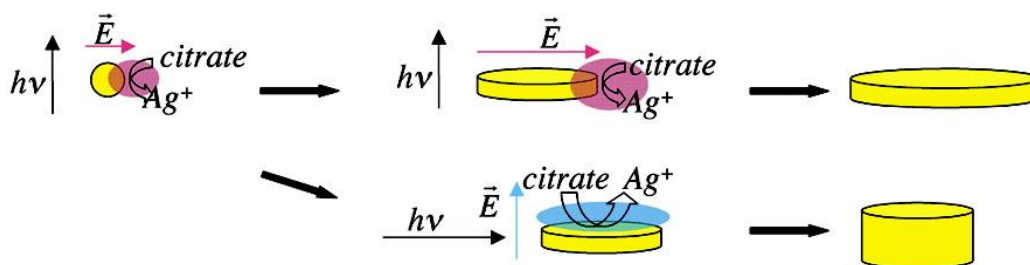

Figure 14 Visual description of possible mechanism ^[31]

Below table shows the solubility rate of tried reducing agents in the variant of three different deep eutectic solvents. As it is already declared, oxaline did not behave as solute any of the tried agents. Two successful solutes were Reline and Ethaine 200 along with two reducing agents as LiBr and Citric Acid.

DES[0,1M AgCl]	Reducing Agent	Solubility at 100mL /g
Ethaline	LiBr	0.8
Ethaline	Citric Acid	1.875
Reline	LiBr	0.032

Table 15 Solubility rate of reduced agents

There are also other tests done with UV in order to determine the peaks of the agents in Ethaline 200. Two measurements were completed with and without reducing agent between 190nm-1100nm wavelengths.

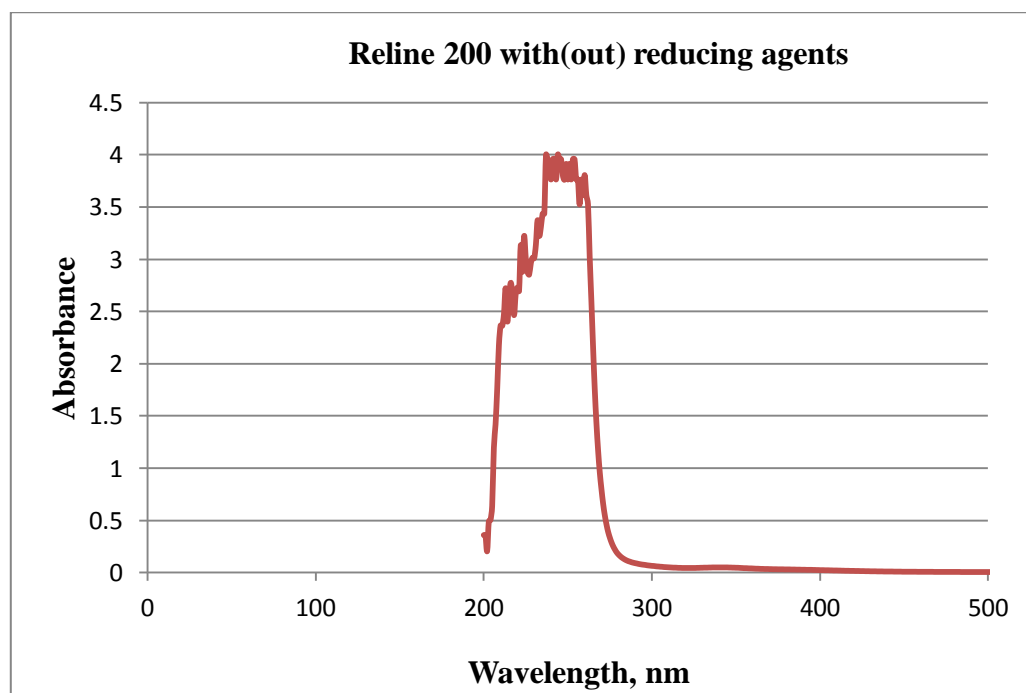
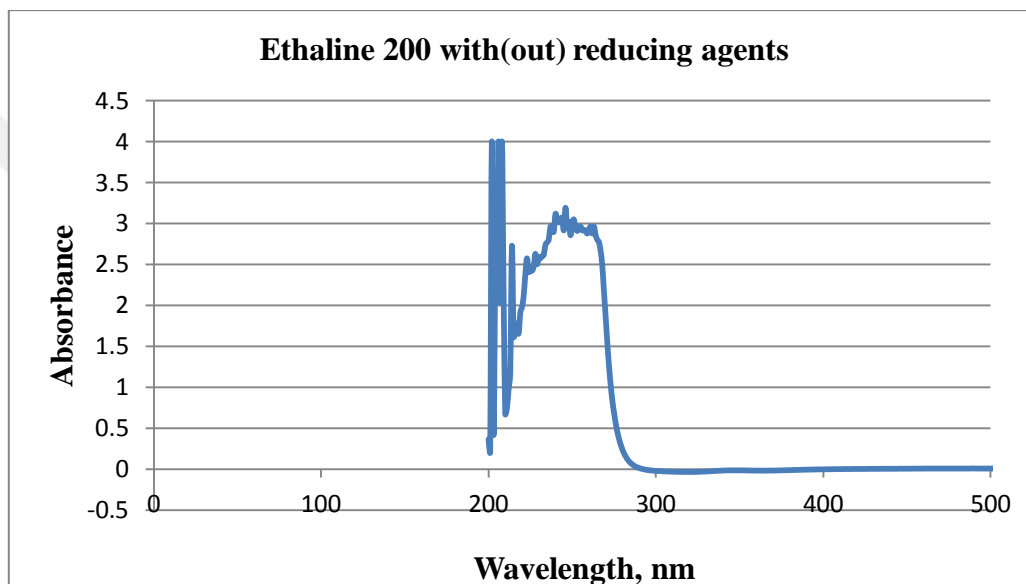

3.1.1 Conclusion

Overall, the experiments completed above show only two reducing agents can be dissolved including lithium bromide and citric acid among variety of them. The solubility ratio shows that the different reducing agents have different solubility capacity in the same deep eutectic solvent.

Moreover, it was also declared that ultra violet spectroscopy is not allowed to determine these reducing agents. There should be two reasons for this observation. The amount of the used reducing can be very low to determine or chemicals can have the similar peaks with Ethaline 200, and reline. As a result, it could not be determined with UV between 190nm and 1100nm wavelength range.

3.2 Photo reduction of silver and gold

There are four different light sources used in these experiments, and only X-ray gave some noticeable results. For this reason, result of ultraviolet light explosion, 630nm laser exposition and 1064nm laser exposition will be given in **one part**, and X-ray results will be given in the **second part**.

3.2.1 UV/630nm and 1064nm lasers

As mentioned in section **2.4.1**, ultraviolet light was exposed to group of samples which includes Ethaline 200 and 0.1M AgCl with some reducing agents reported in section **2.4**. **The table...** above summarizes the general results of the experiments as complete done with UV. As it is seen, there is no reduction have been observed with any of the used lasers regardless their wavelength and power capacity. In addition to this, UV did not release any reduction of silver or any observable peak for any light source.

TABLE



3.2.2 X-ray experiments for reducing process of gold

As it is mentioned in section 2.4.4, four different mixtures with repeating samples as totally 16 tubes were exposed to X-ray source.

Tube Code	Quantity	AgCl / mol/dm ⁻³	AuCl mol/dm ⁻³	LiBr / g	Citric Acid /g	30s 0.6 and 3kW	30s 0.6 and 3kW
A1	4	0.1	-	0.032	-	+	+
A2	"	0.1	-	-	-	"	"
A3	"	0.1	-	-	0.075	"	"
A4	"	-	0.13	-	-	"	"

Table 17 Brief description of practiced experiments with X-ray

After X-ray exposure, the tubes pictured directly, and the all gold containing tubes was carrying gold as precipitation on the bottom of the mass tubes.



Picture 2 One set of X-ray exposed tubes after a while from exposure (A4 is in intense colour due to gold nanoparticles)

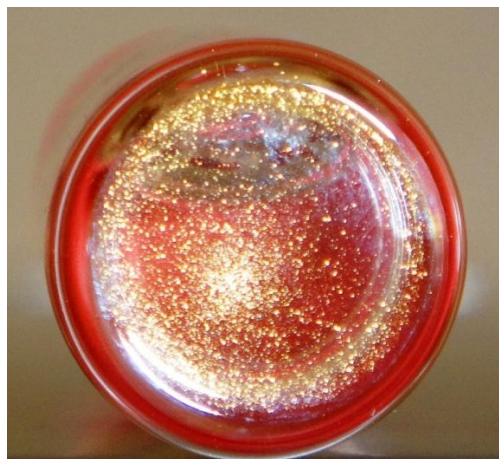

Picture 3 Bottom of one of gold containing tube

Although it is not quite clear at above picture due to very fine gold particles all around the tube along with pale background, and precipitation mainly cumulated at bottom, quite amount of gold is in there. After a few hours later with the assist of vortex mixer, all particles started to merge in the tube with clear visibility.

The pictures below clearly show the cumulated gold with different backgrounds with the assist of the flash light.

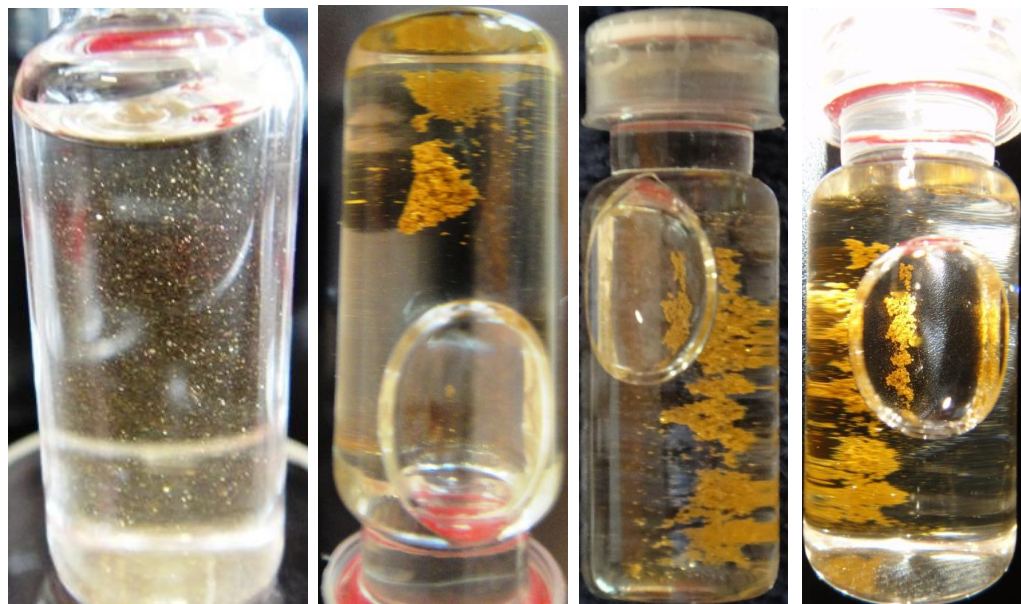

Picture 4 Four different pictures have been taken to show solid gold

After the visible gold observation, it was important to calculate the efficiency of the reducing process since initial amount of gold was calculated as 0.0512g in section 2.1. For this reason, different techniques have been considered and cleaning ethaline 200 from solution by using some solvents, mainly water, to clean the DES and leaving the gold alone was decided as most reasonable method since the time was limited and the other things was required more attention. Basically, the procedure was followed as;

- ❖ Mass containing tube was diluted with water as 10 ml
- ❖ Mass tube was put in centrifuge in 4000rpm for 10 minutes
- ❖ Liquid on top of gold precipitation was taken
- ❖ Mass tube was completed 10 ml with methanol
- ❖ Vortex mixture was used to re-shake and remove the gold particles from edge of tubes

- ❖ Centrifuge and drawing liquid processes as applied again
- ❖ Ultrasonic cleaning unit has been used by sinking the tube and applying 35 kHz for 10 minutes

All the processes mentioned above were repeated more than 5 times for each tube. However, high amount of fine gold particles, and possibly unseen nanoparticles, have been drawing with liquid above from the precipitated gold as seen the picture below;



Picture 5 Clearly visible un-recovered gold particles in the liquid removed after each centrifuge

In order to avoid this, last two tube were put in centrifuge unit for more than 30 minutes, but the results did not change. In addition to this, there were also visible gold particle unrecovered in very small size with fine distribution all around the both mass and centrifuge tubes as seen picture;



Picture 6 Fine gold particles could not be removed from cohesive tube edges

After all the possible DES removing processes applied, the pure gold obtained as shown in pictures below;

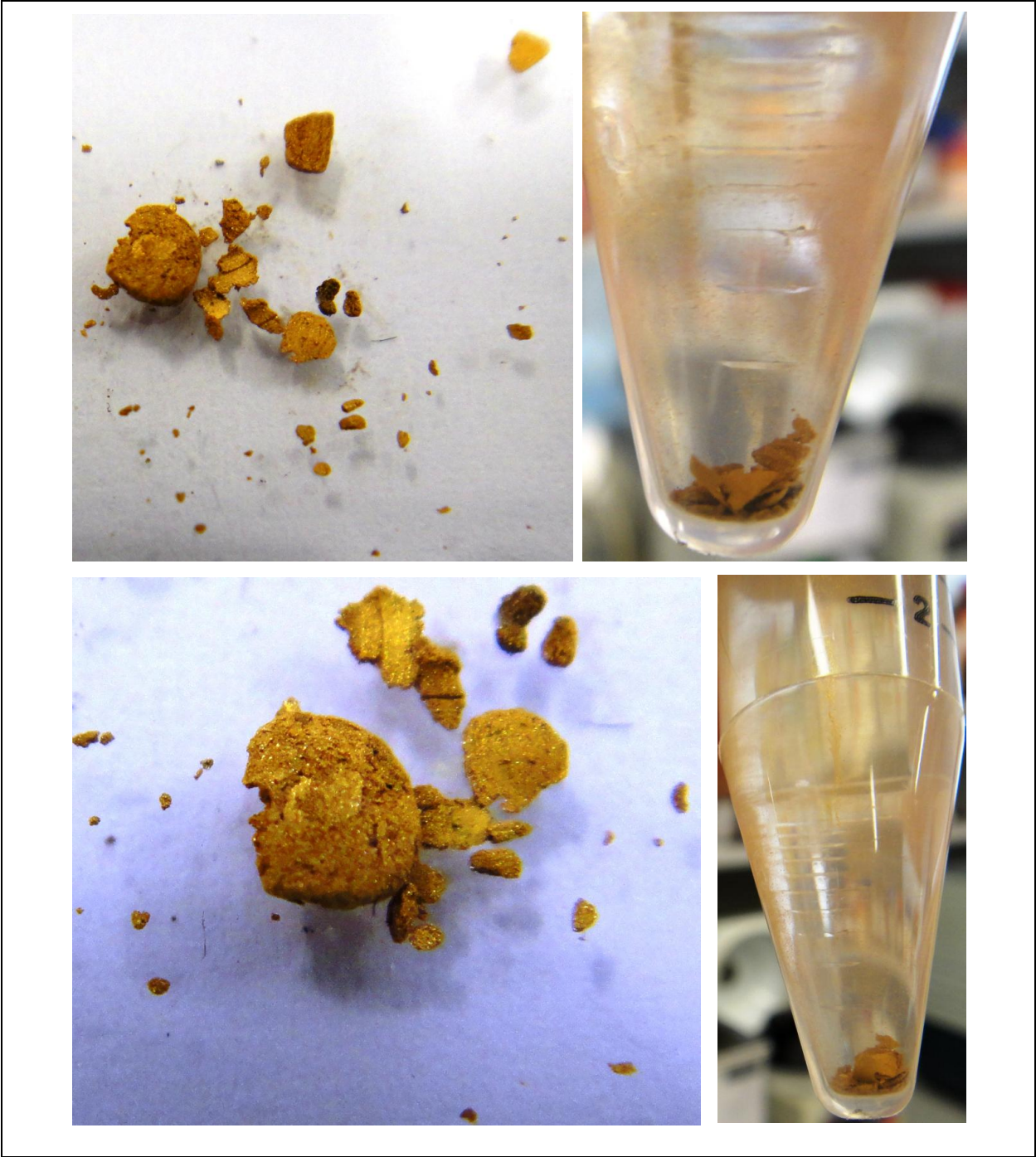

Picture 7 Gold particles after Ethaline 200 removed from 2ml mass tube

Obtained gold from one mass tube has been weighted; the weight and efficiency calculation done below is the sample of 300 seconds 3.0kW X-ray exposed;

- Empty centrifuge tube was weighted as 6.6555 g
- After DES cleaning processes, it is weighted with dry gold as 6.6742 g
- Gold amount ; $6.6742 - 6.6555 = 0.0187$ g.
- Net recovered gold percentage = $\frac{0.0187 \times 100}{0.0512} \sim \mathbf{\% 37}$

Although the result show roughly %37 recovery, it is strongly believed that this quantity is quite lower than the real recovered amount when we consider three loss points in which particles cannot be recovered at all around mass and centrifuge tube. In addition to this, there are also lots of losses after centrifuge in which very small particles did not cumulate on bottom of the centrifuge tube and have been carried along with DES solvent chemical, water, and methanol.

After obtaining gold particles, SEM tests have been carried on in order to determine any impurity in the particles. Obviously, we did not expect to see any surprise since the color is just yellow. Particles have been put on carbon sticky pads for the analyzing process of SEM, and the results shows **%89.91** (in weight %) is gold (see **Appendix 1.9**).



Picture 8 SEM test sample; gold particles on carbon sticky

3.2.3 Conclusion

Although it is expected to observe reductions from practiced experiments with both X-ray and other light sources by depending on the studies of (Alexander, 2009), (Mathieu, 2003) and (Munro, 1995) it could not be observed any reduction of the silver, or any visible particles, colour changes. In the same way, UV tests did not show any chemical formation or differences in logical level. In the silver side, all published articles, mentioned above, mainly discussed AgNO_3 with partially successful results, and thus; it may possibly due to AgCl structure, or the medium used Ethaline 200 in which solutions is already saturated with certain amount of chlorine ions, and maybe, in some way, this situation is not allowed to observe reduction. In normal conditions, Ethaline 200 should behave as both protective agent and reducing agent as generally room temperature ionic liquids behave ^[36]. To understand the mechanism of the silver, and the reasons behind no observed reduction, FT spectra, EXAFS may be studied. Another unexpected scenario is having silver nanoparticles which could be detected by TEM, but the aim of the experiment is not having the silver nanoparticles. However, there are still some variables can be changed which will be discussed in the **4.0**.

In the side of the gold processes, it is not wrong to say that X-ray is not perfectly practised way to reduce gold from complex mixtures in the industrial applications. On the other hand, it still leave the doors open for improvements and different studies, such as chemical catalysis, spectroscopic detection, and biomedical marking ^[37]. An interesting article has been published while this experiment was carrying on. Ma and co-workers suggest the mechanism of the formation of gold nanoparticles. Although there are suggested mechanisms in the literature reported by Wei and co-workers ^[38], Ma and co-workers study is also quite gratifying with strong supportive data.

Another point is the used ionic liquid, [BMIM] has been used as RTIL in their study, gold mixture in their study was the form of AuCl_4 , which carries the enough chloride ions that already provided massively by our medium of Ethaline 200. Briefly, we can possibly suggest their mechanism of gold nanoparticle formation as similar of our study. Previous studies mainly declares that the $\text{Cl}_3^- \text{Au}-\text{AuCl}_3^-$ dimer was proposed as the first intermediate that basically mentions Au-Au bond formation starts along with the cleavage of the Au-Cl bonds ^[37]. However, in Ma and co-workers study, Chloride ions surrounded the Au cation is gradually reduced, and Au-Au nanoparticle formation is started after Au-Cl bond is reduced to two. Thereafter, cumulating step of Au ions into clusters start gold nanoparticles is produced as shown below;

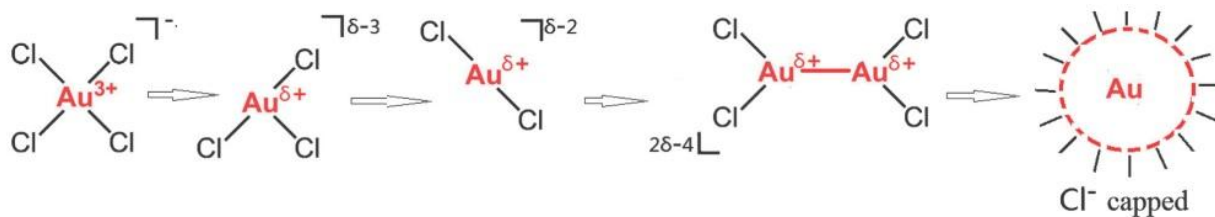

Figure 15 Formation process of gold cluster from Ma's group^[x2]

Moreover, both our study and their study used X-ray with some noticeable differences as follow;

- Ma's group was used a huge synchrotron radiation facility called BL14W1 of Shanghai^[x2] has 3.5 Giga electron volt, 140-200 mA along with 10^{11} - 10^{12} photons bombardment.
- Our study has been powered by a very light power supported X-ray analyzer 3.0 kW in total.
- Ma and co-workers expose their sample around 12 hours as maximum, and formations start from after 3-4 hours.

As it is clearly seen that conditions of the Ma and co-workers experiment is quite different than the conditions of our experiment especially in terms of cost and time both factor are hundreds of times lower than the Ma and co-workers experiment^[37]. The conditions of our experiment can be changed, and nanoparticles can easily be prepared rapidly. It is strongly believed that other light sources may also easily produce gold nanoparticles in Ethaline 200 since the short time and low power options produces a great deal of visible particles.

3.3 Chemical reducing agents for selectivity of silver

3.3.1 Potential window shifts with target reducing agents

As declared in the part of section 2.5, first tests are to observe potential shift against silver. Interestingly, it was observed that chosen reducing agents did not affect the redox potential of the solution compared to redox chemistry for silver. All the molarity of mixtures used to have voltammetry graphics below are **0.01M**.

- The first set of four graphics will show the **0.01M** AgCl of ethaline, catechol, hydroquinone and sodium thiosulfate pentahydrate.
- Second graphic will be mixture of ethaline and catechol merged graphics
- The third graphic will be mixture of catechol and hydroquinone.

- Final graphic will be merging of all of them to show the very little change in redox potential of the medium.

3.3.2 Conclusion

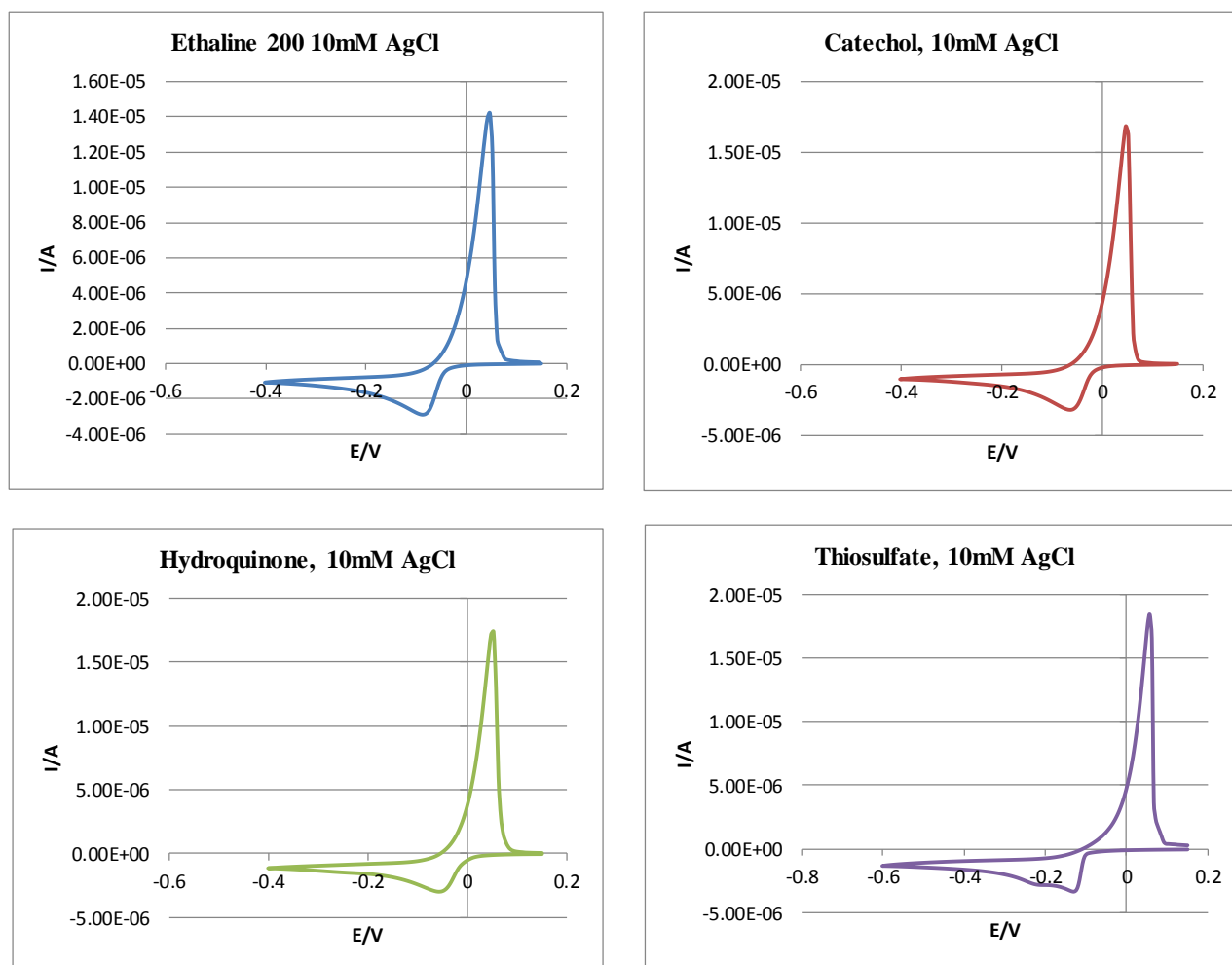
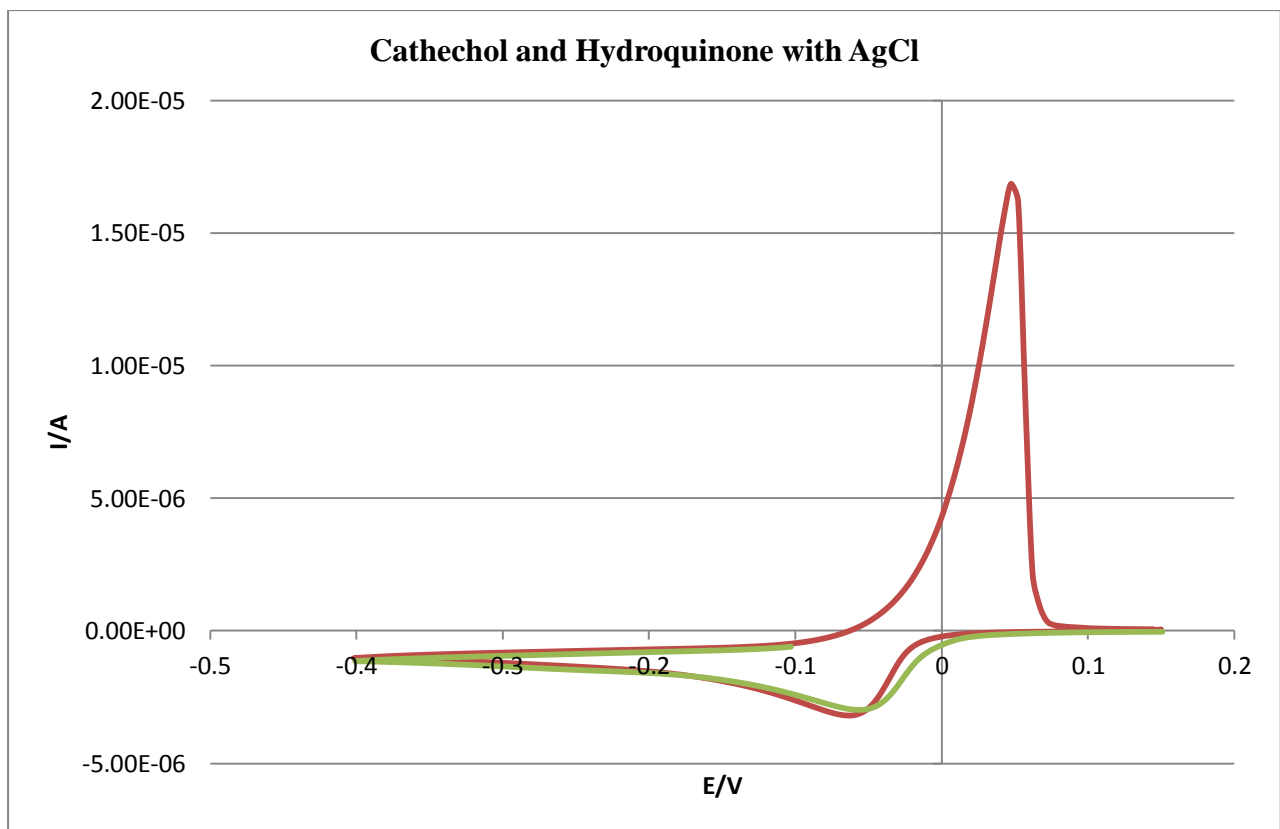
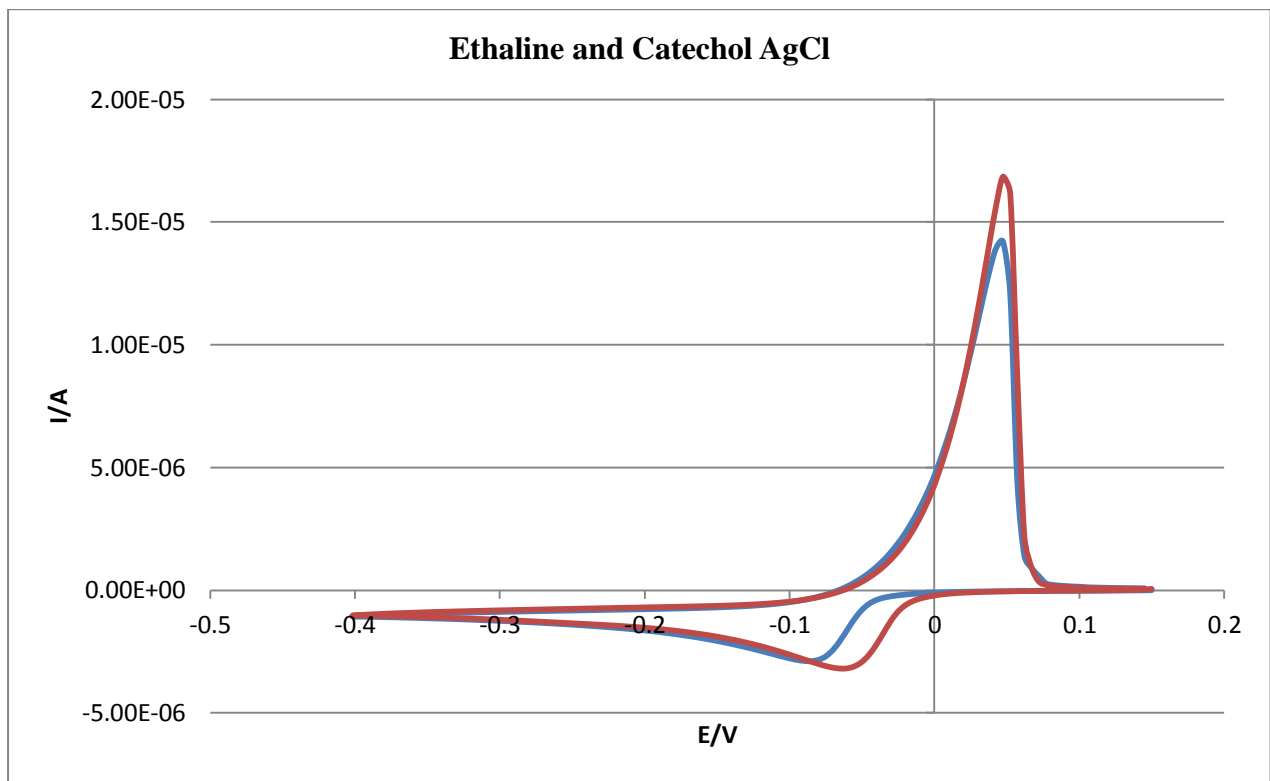
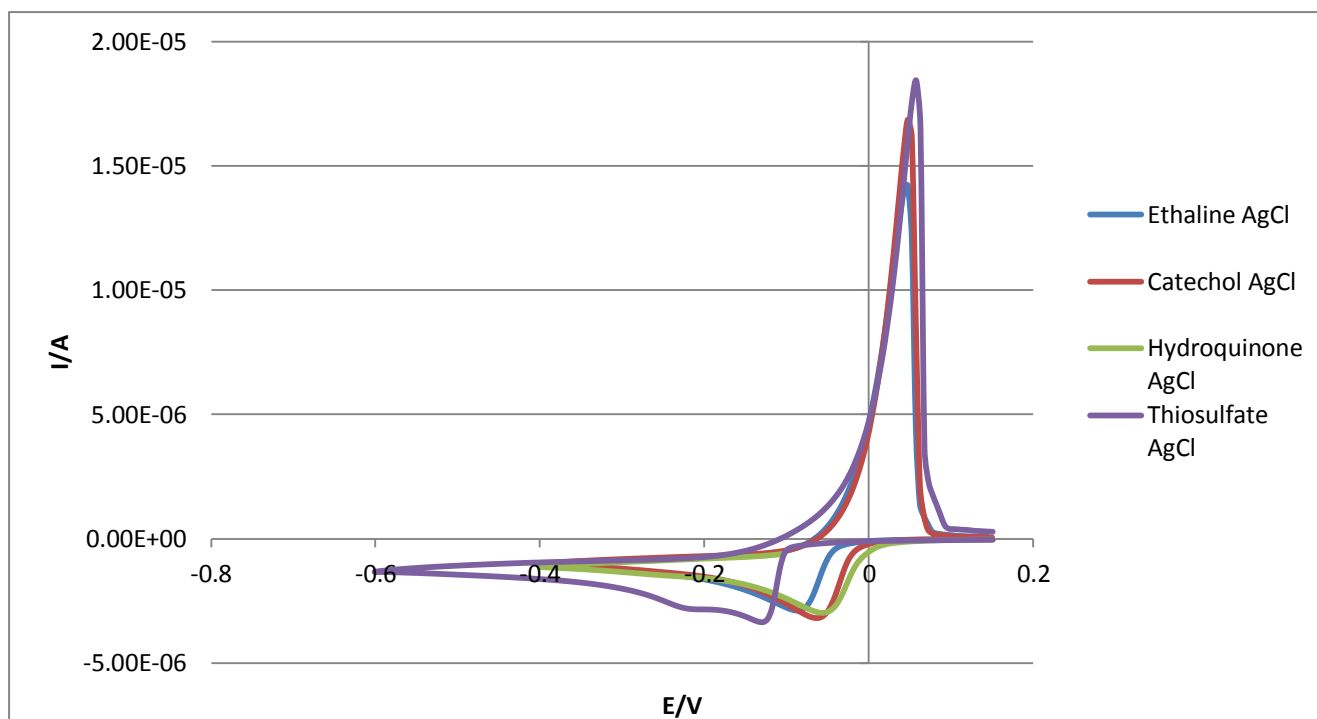

Figure 16 Voltammogram of set of four reducing agents with 0.01M AgCl



The last figure below carries all four agents to show clearly little changes from the reference solution.



As it shown at above figures, interestingly, chosen reducing agents did not cause important change in potential windows towards reference substances. It can give the idea that kinetic mobility, ion transfer properties other a few does not change significantly. Other noticeable observation comes from thiosulfate addition to the silver containing solution. After redox potential experiments were carried out, a few hours later, black particle formation was started in the solution tube.

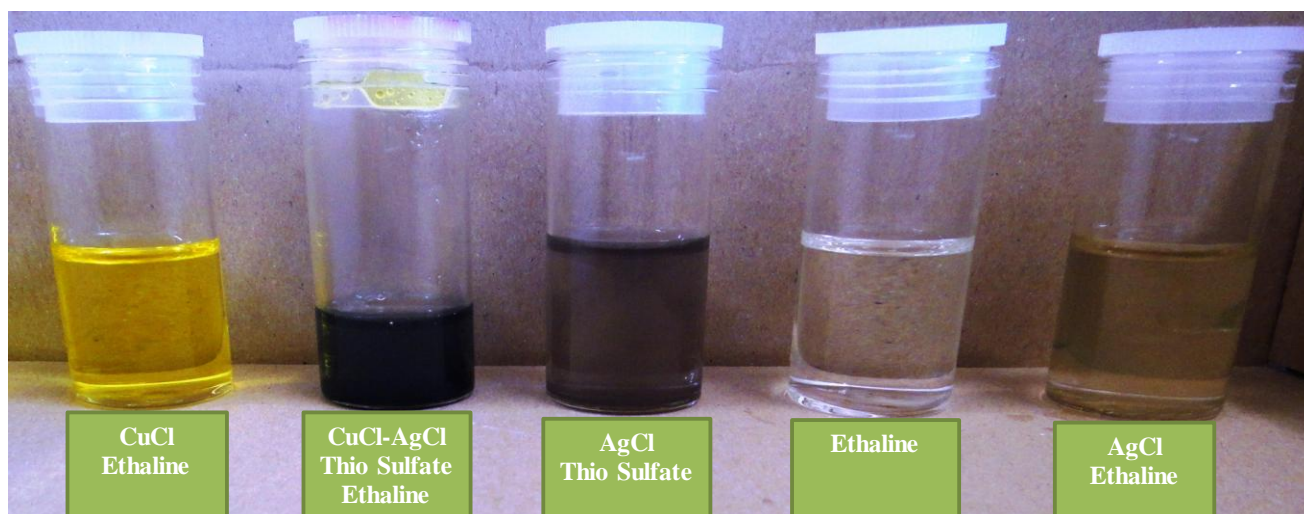

Figure 17 The picture of the after a while containing CuCl, AgCl combinations in Ethaline 200

It seems both Copper and silver complex have been reduced in time as, most probably, CuS, and AgS. In addition to this, there can be also some sulphate precipitates, such as $[\text{Cu}(\text{S}_2\text{O}_3)_3]^{5-}$. A small detail should be given here, Copper based precipitation occurred much later than silver based one, and just the silver precipitation have been purified from Ethaline 200 by just using water, not methanol or others did in the section 3.2, but other procedure was similar with 3.2 gold Ethaline 200 purification steps. Then, SEM with EDX have been performed on Silver based thiosulfate precipitation on carbon sticky pads.

Spectrum	In stats.	S	Cu	Ag	O	Total
Spectrum 1	Yes	11.5		66.37	22.13	100
Spectrum 2	Yes	12.03	0	65.14	22.84	100
All results in weight%						
Max.		12.03	0	66.37	22.84	
Min.		11.5	0	65.14	22.13	

Table 18 SEM results of silver(I) chloride with thiosulfate pentahydrate

These results show that precipitation is mostly the mixture of $\text{S}_2\text{O}_3^{2-}$ with Ag rather than AgS which was the first estimation.

4.0 Future Work

In our experiments three different tests have been done to recover precious metals from mixed solutions.

In the first section, different reducing agents, mainly chosen from previous studies, and tried for three different deep eutectic solvents. Instead of using directly declared reducing agent in the literature, their derivatives used, and this may possibly affected some of the results, especially in the part of silver reduction.

In the second section, different light sources have been used as electron/photon source in order to reduce the gold, and mainly silver. In these studies room temperature has been decided as operation temperature, and this may possibly affected some of the results, and did not show some expectations since the literature studies are not always use the room temperature due to valance electron bonds highly affected the Gibbs energies of the mediums. Furthermore, many experiments resulted with success in reduction of the silver, nanoparticle formation of silver, and nanoparticle growing of the silver used AgNO_3 instead of AgCl which mainly used in our experiments.

In the last section, cyclic voltammetry has been used to determine redox potential of the silver with different reducing agents. It is mainly expected to have a reversible process which carries and transfer electron between silver ions and included species, and precipitate the silver at the end of the process. This study is quite unique than tried other methods in this study. However, no gratifying results have been observed, used reducing agents tend to reduce or oxidise irreversibly. However, there are some points have been observed. Firstly, chosen reducing agents have nearly no effect of reference redox potential silver. Additionally, thiosulfate has been formed precipitation with silver and copper species.

4.1 Improvements and suggestions on future work

4.1.1 Dissolution

Ethaline 200 used as primary solvent in most of the experiments, and a couple of reducing agent could be tried due to both availability and time scale. There are also some others can be tried detail in three of the DES, such as sodium dodecyl sulphate, hydrazine dhydrate and some other declared in the literature.

Reline and oxaline can be tried in different conditions. Although reline does not allow operating at high temperatures as oxaline, it is viscosity is lower than oxaline, and may possibly worth to try with other reducing agents.

Oxaline should be checked in the literature for some reducing agents, but the viscosity is the major problem even in the step of stirring, and this becomes worse when reducing agents dissolved. For this reason, the best way to make oxaline suitable is using some reducing agents which decrease the viscosity of the oxaline without changing other properties a lot.

4.1.2 Photo reduction

Mainly two different lasers, ultraviolet light, and X-ray have been used to reduce silver with the effect of photon hitting to valance electrons of metal halide, and reducing it as elemental form. There are two metal has been focused on for recovery purposes. Silver and gold are both in chloride forms. Although there are great deal of experiments have been carried on silver reduction in the literature as declared in **3.0** with different mediums, it was not obtained as in elemental form. First of all, all the samples obtained in our study can be investigated with transmission electron microscopy (TEM) in order to check whether any nanoparticle formation occurred. Although lots of UV spectra have been

practised with those samples, and could not obtain any reliable data, this still did not show exactly absence of nanoparticles.

Alternatively, AgNO_3 can be tried as second option, and also in situ time-resolved EXAFS experiments, in situ synchrotron SAXS/WAXS experiments, in situ XRD, and FT spectra tests can be done to observe the Cl^- ion behaviour along with metal behaviour and the cleavage points if there are [x3].

The main advantage of this experiment is to open some study areas along with the observation of the capacity of Ethaline 200 for gold based halides. Since, gold nanoparticles have great importance in various areas as mentioned in section 3.0. It is possibly will give noticeable investigations of gold nanoparticle production. In our experiments, maximum X-ray irradiation time is 300 seconds. In addition to this, formation of nanoparticle has been observed even in the short time scale as 30 seconds, and maybe, most probably, formation happened in first 10 seconds, but not tried. It is strongly believed that other light sources even can easily produce gold nanoparticles in Ethaline 200 since the short time and low power options produces a great deal of particles and possibly nanoparticles, but not analysed with TEM.

4.1.3 Chemical reducing agents with CV

Three different reducing agents, sodium thioisulfate pentahydrate, catechol, and hydroquinone have been tried with Ethaline 200 and cyclic voltammetry in order to observe redox potentials, none of them seems to suitable for continuous processes since irreversible reductions have been occurred. The best data may possibly be observed is to obtain a group of reducing agents in one line to show the differences of redox potential observed.

5.0 References

1. British Metal Recycling Association
2. A.P. Abbott, G. Frisch, J. Hartley and K. S. Ryder, *Green Chem.*, 2011, **13**, 471 (DOI:10.1039/c0gc00716a).
3. F. Habashi, *Hydrometallurgy*, 2005, **79**, 15-22 (DOI:10.1016/j.hydromet.2004.01.008).
4. D.A. Wright and P. Welbourn, *Environmental Toxicology*, 2002, Cambridge University Press, Cambridge, UK
5. V.T. McLemore, *Basics of Metal Mining Influenced Water*, 2008, **1**, Society of Mining, Metallurgy and Exploration, Littleton, CO, USA
6. A.R. Burkin (2001). *Chemical Hydrometallurgy: Theory and Principles*. Word Scientific. 235-236.
7. L.S. Ettre, *Pure and Applied Chemistry*, 1993, **65**, 819-872 (DOI:10.1351/pac199365040819).
8. A. Marton, *Pure and Applied Chemistry*, 1997, **69**, 1481-1488 (DOI:10.1351/pac199769071481).
9. P. Barbaro and F. Liguori, *Chem. Rev.*, 2009, **109**, 515-529 (DOI:10.1021/cr800404j).
10. S.J.G. Casaroli, B. Cohen, A. R. Tong, P. Linkson and J. G. Petrie, *Minerals Eng*, 2005, **18**, 1282-1288 (DOI:10.1016/j.mineng.2005.05.017).
11. D. J. Fray and G. Z. Chen, *Materials Science and Technology*, 2004, **20**, 6 (DOI:10.1179/026708304225012242).
12. Walden, P.; *Bull. Acad. Impér. Sci. St. Pétersbourg*, 1914, **8**, 405-422.
13. A.E. Visser, R. P. Swatloski and R. D. Rogers, *Green Chem.*, 2000, **2**, 1-4 (DOI:10.1039/a908888a).
14. J.H. Davis, K. J. Forrester and T. Merrigan, *Tetrahedron Lett.*, 1998, **39**, 8955-8958 (DOI:10.1016/S0040-4039(98)02070-X).
15. F. E. P. Dr., *Electrodeposition from Ionic Liquids*, John Wiley & Sons, 2008.
16. J.D. Holbrey and K. R. Seddon, *Journal of the Chemical Society, Dalton Transactions*, 1999, 2133-2140 (DOI:10.1039/a902818h).
17. P. Bonhôte, A. Dias, N. Papageorgiou, K. Kalyanasundaram and M. Grätzel, *Inorg. Chem.*, 1996, **35**, 1168-1178 (DOI:10.1021/ic951325x).
18. H. Tokuda, K. Hayamizu, K. Ishii, M. A. B. H. Susan and M. Watanabe, *The journal of physical chemistry.B*, 2005, **109**, 6103-6110 (DOI:10.1021/jp044626d).
19. A.P. Abbott, J. C. Barron, K. S. Ryder and D. Wilson, *Chemistry*, 2007, **13**, 6495-6501 (DOI:10.1002/chem.200601738).
20. J.A. Whitehead, J. Zhang, N. Pereira, A. McCluskey and G. A. Lawrance, *Hydrometallurgy*, 2007, **88**, 109-120 (DOI:10.1016/j.hydromet.2007.03.009).
21. J.A. Whitehead, G. A. Lawrance and A. McCluskey, *Green Chem.*, 2004, **6**, 313 (DOI:10.1039/b406148a).
22. A.P. Abbott, G. Frisch, J. Hartley and K. S. Ryder, submitted for publication.
23. *EXAFS Investigations of the Mechanism of Facilitated Ion Transfer into a Room-Temperature Ionic Liquid*, - American Chemical Society.

24. M. L. - Dietz and J. A. - Dzielawa, - *Ion-exchange as a mode of cation transfer into room-temperature ionic liquids containing crown ethers: implications for the 'greenness' of ionic liquids as diluents in liquid-liquid extraction*, - The Royal Society of Chemistry.
25. A.P. Abbott, G. Frisch, H. Garrett and J. Hartley, submitted for publication.
26. J. Cui and L. Zhang, *J. Hazard. Mater.*, 2008, **158**, 228-256 (DOI:10.1016/j.jhazmat.2008.02.001).
27. CH3206 – Making X-rays – (Advance Physical Chemistry) by Dr. Gero Frisch (University of Leicester) 2013-2014
28. Official website of Panalytical, <http://www.continuumlasers.com/products/>
29. Official website of continuum lasers, <http://www.continuumlasers.com/products/>
30. 2008 Encyclopaedia Britannica, Inc.
31. 1. M. Maillard, P. Huang, and L. Brus, *Nano Letters*, 2003, **3**, 1611–1615.
32. 1. C. H. Munro, W. E. Smith, M. Garner, J. Clarkson, and P. C. White, *Langmuir*, 1995, **11**, 3712–3720.
33. L. C. Courrol, F. R. de Oliveira Silva, and L. Gomes, *Colloids and Surfaces A: Physicochemical and Engineering Aspects*, 2007, **305**, 54–57.
34. 1. A. J. Alexander and P. J. Camp, *Crystal Growth & Design*, 2009, **9**, 958–963.
35. 1. A. Henglein and M. Giersig, *The Journal of Physical Chemistry B*, 1999, **103**, 9533–9539.
36. M. Antonietti, D. Kuang, B. Smarsly, and Y. Zhou, *Angewandte Chemie* (International ed. in English), 2004, **43**, 4988–92.
37. J. Ma, Y. Zou, Z. Jiang, W. Huang, J. Li, G. Wu, Y. Huang, and H. Xu, *Physical chemistry chemical physics: PCCP*, 2013, **15**, 11904–8.. Yao, Z. Sun, Y. Li, Z. Pan, H. Wei, Y. Xie, M. Nomura, Y. Niwa, W. Yan, Z. Wu, Y. Jiang, Q. Liu, and S. Wei, *Journal of the American Chemical Society*, 2010, **132**, 7696–701.

Appendix

Figure 1: Basic flow chart of metal recovery redrawn from one of the references [2].

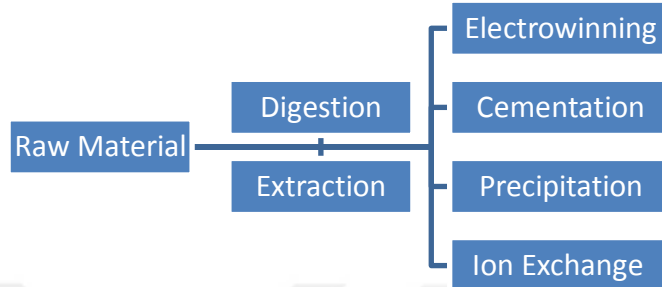

Figure 2: polystyrene-divinylbenzene copolymers bearing ion-exchanging functional groups

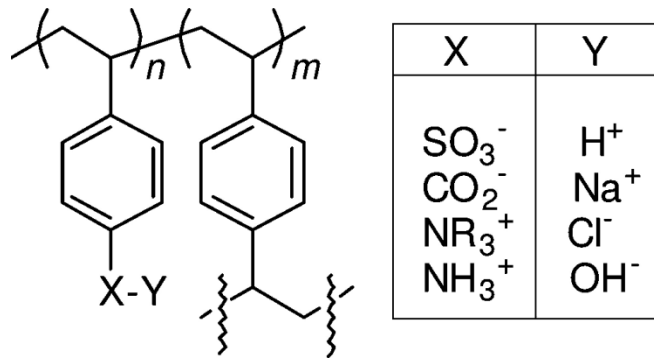

Figure 3: example of cementation for metal removal in zinc electrowinning circuits [10].

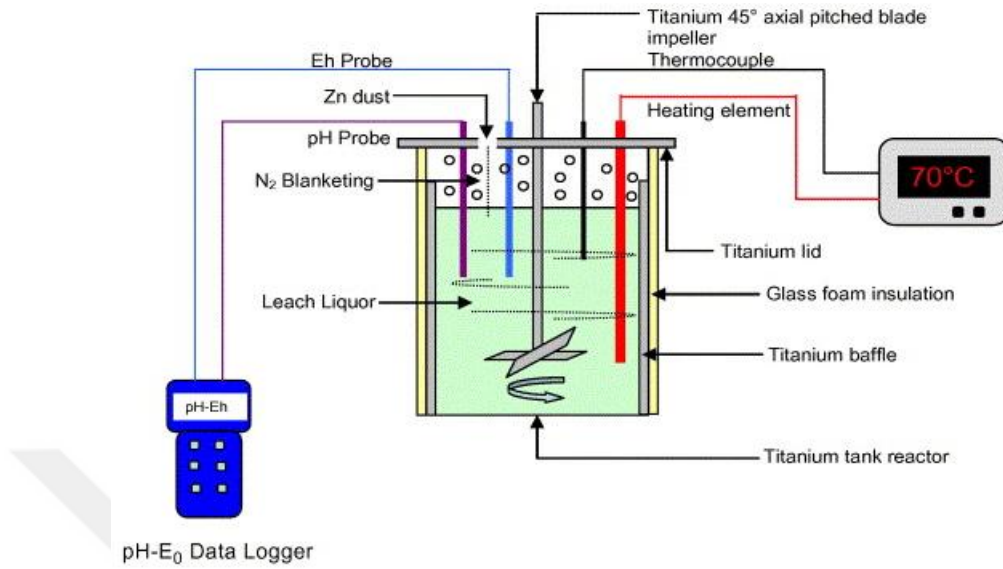

Figure 4: One of the pyrometallurgical application from 1950s, which was stopped due to large amount of pollution was created by the reactor.

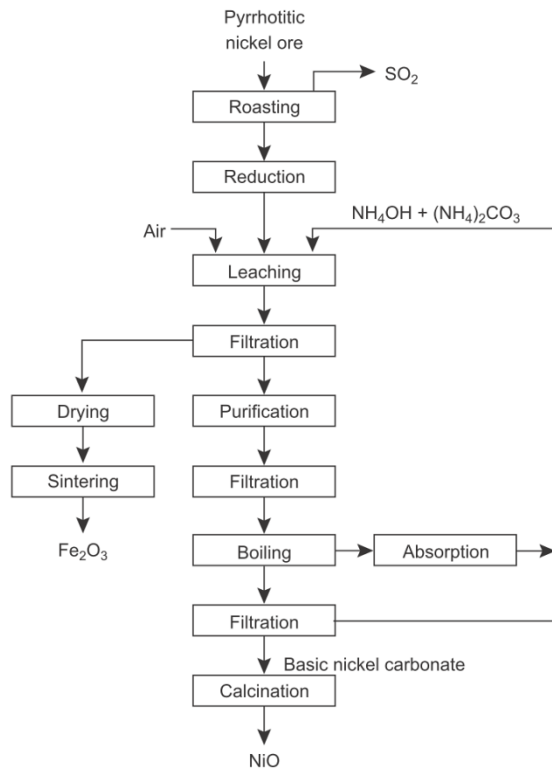

Figure 5: Pure Zinc Recovery from ZnO, heavy metal Cd, and CO, CO₂ gases release.

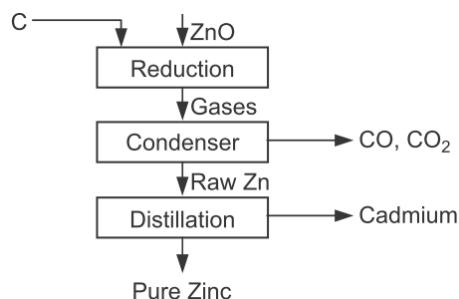
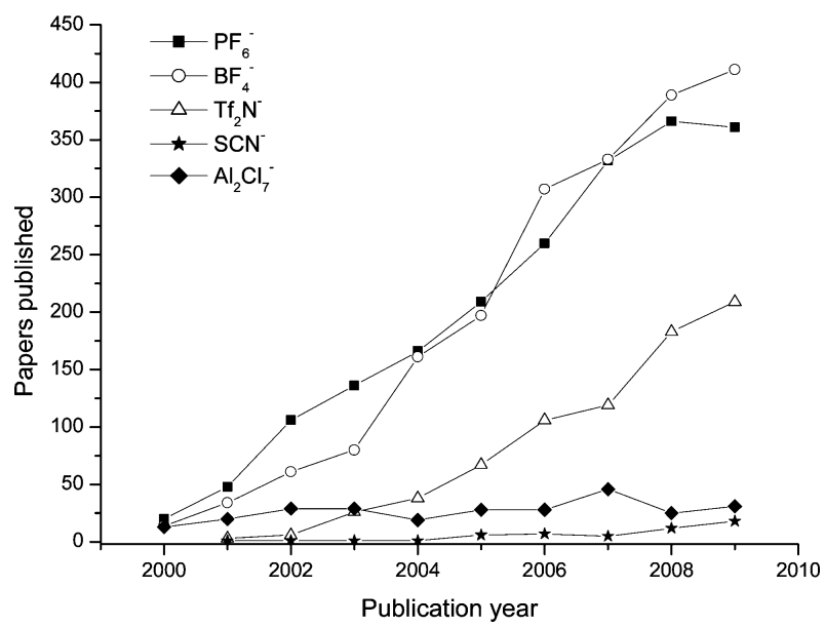

Figure 6: Commonly selected cations and anions for the purpose of metal recovery based ionic liquid preparation.

Common cations	Discrete anions
<p> $R_1 = \text{CH}_3$ $R_2 = \text{Et}$ C₂mim $R_2 = \text{Bu}$ C₄mim $R_2 = \text{Hex}$ C₆mim </p>	<p>-</p>
<p> $R = \text{CH}_3$ BPY $R_1R_2R_3R_4N^+$ $R_1=R_2=R_3=\text{CH}_3$ $R_4=\text{C}_2\text{H}_4\text{OH}$ Choline </p>	<p>-</p>
	<p>Tf₂N⁻</p>

Figure 7: Trend of preferred ionic liquids from 2000 to 2010 shows that BF_4^- and PF_6^- are the most used and researched ones among five of them.



Appendix of Experimental Part

1.1

Axios ^{mAX} -Advanced		
Axios ^{mAX} – wavelength dispersive spectrometer with controlling software		
	Standard configuration	Optionally configured items
X-ray tube	Rh-anode SST-mAX ⁵⁰ with ZETA technology, thin window and CHI-BLUE coating	Cr-anode, other anodes on request
Generator	4.0 kW	
Tube filters	Choice of four	Brass 100, 300 μm, Al 200, 750 μm, beam stop, Be tube protection filter
Collimator mask	6 position programmable mask (6, 10, 20, 27, 30, 37 mm)	
Primary collimators	Choice of three	100, 150, 300, 550, 700, 4000 μm
Crystals	PX10, LiF220, PE002 curved, PX1, Ge111 curved	LiF420, TIAP coated, PX1, PX4a, PX5, PX6, PX7, PX8, PX9 (max. 8)
Detectors	Flow, Scint	Sealed Xe (duplex with flow)
Fixed channels		Hi-Per channels, max. 2, for B to Mg
Loading		Continous: 30 s/sample less instrument overhead Direct: up to 10 2/sample less instrument overhead
Analysis medium	Vacuum	He (N ₂) path
Dust removal		Dust removal device
Spinner	Included	
Sample changer	Included	High-capacity changer up to 209 samples (32 mm) or 140 samples (40 mm)
Sample identification		Integrated barcode reader
Software	SuperQ, Omnian	Pro-Trace, FP Multi, SPC, UAI, Enhanced Data Security
Industry-specific modules		WROXI minerals module CEMOXI cement module Oil-Trace petro module ADPOL and TOXEL polymer modules NiFeCo-FP and Cu-base-FP metals modules

1.2



1.3



1.4

Description	ML I
Repetition Rate (Hz)	1-15
Energy (mJ)	
1064 nm	28
532 nm	12
355 nm	4
266 nm	2
Pulsewidth ¹ (nsec)	
1064 nm	5-7
532 nm	3-5
355 nm	3-5
266 nm	3-5
Linewidth (cm ⁻¹)	1
Divergence ² (mrad)	<3
Beam Diameter (mm)	3
Jitter ³ (±ns)	0.5

1.5

Specifications	
Max. Tube Size	200ml
Max. Capacity	800ml
Max. Speed	4,600 rpm
Max. RCF	3,120 x g
Time Display Range	0–30 mins
Time Accuracy	±1 min
Dimensions	
Height	336mm
Width	436mm
Depth	487mm
Weight	36kg

1.6

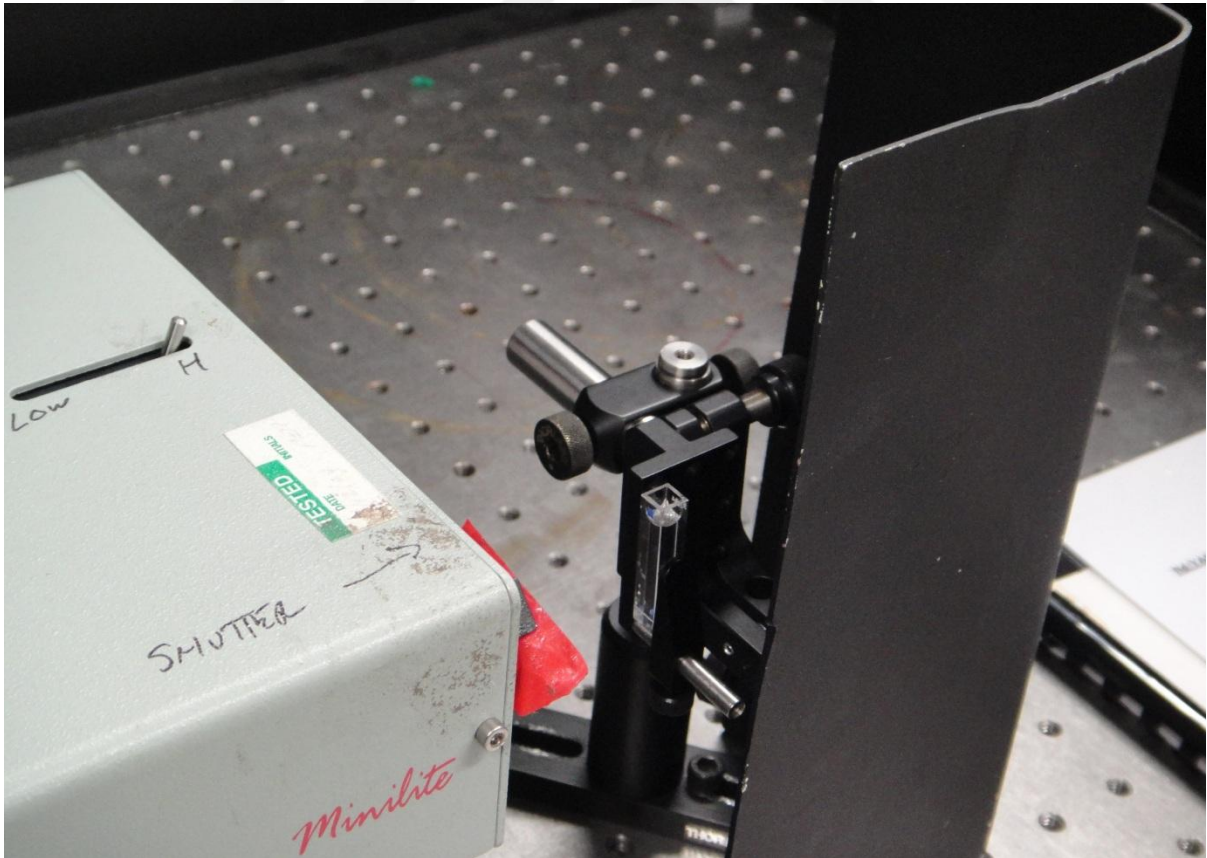

1.7

Citrate molecule orientation on the silver nanoparticle colloid surfaces [1], prepared with ChemDraw

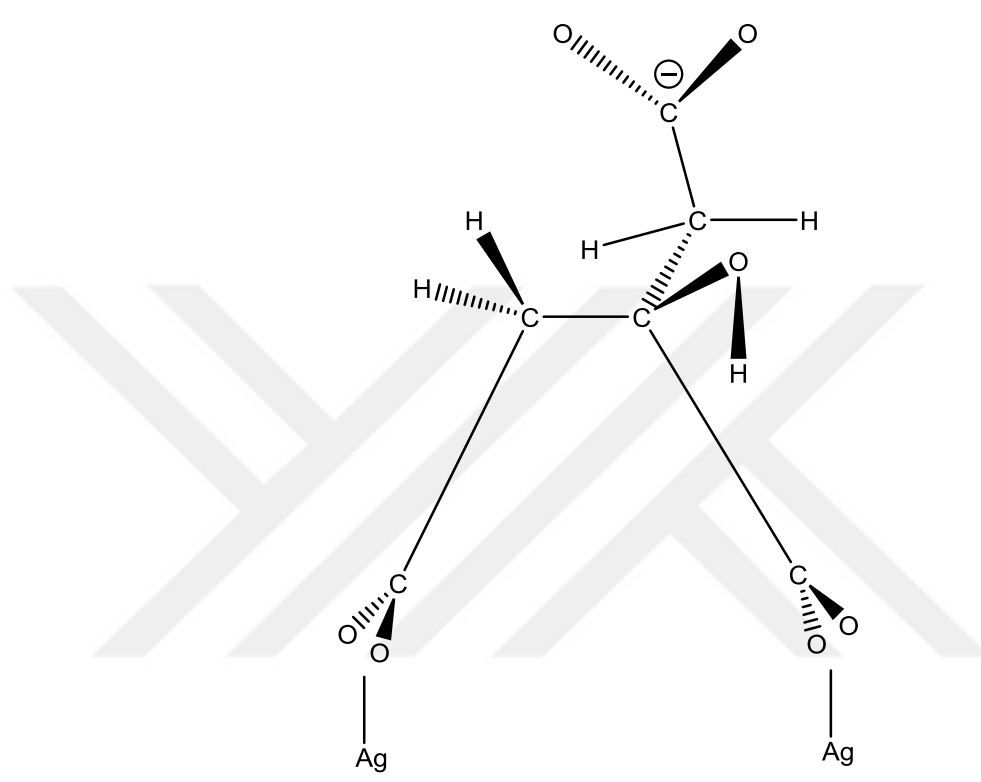

1.8

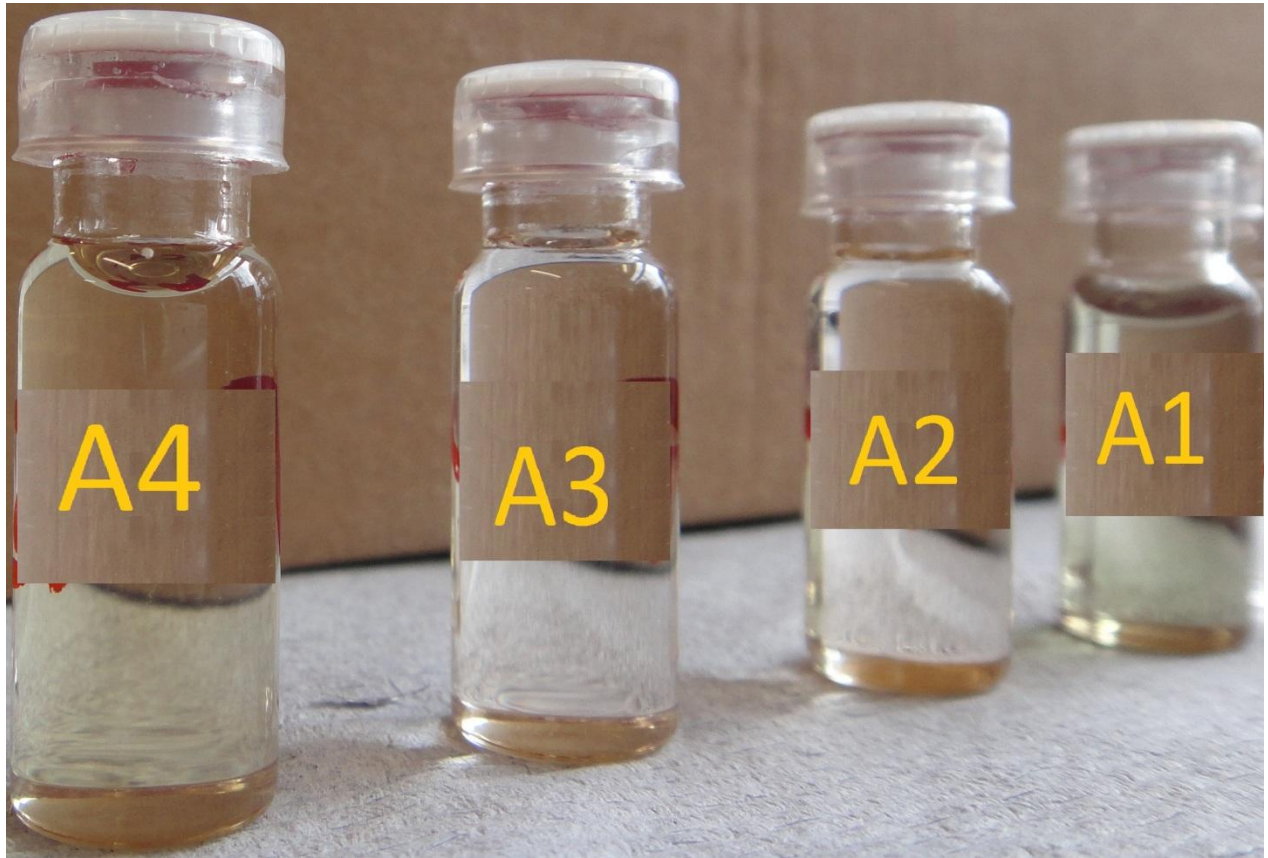

1.9

