

# **Monitoring the Performance of a Small-Scale Wind Turbine**

**Mehdi Lajavardi Esfahani**

Submitted to the  
Institute of Graduate Studies and Research  
in partial fulfillment of the requirements for the Degree of

Master of Science  
in  
Mechanical Engineering

Eastern Mediterranean University  
February 2012  
Gazimağusa, North Cyprus

ABSTRACT

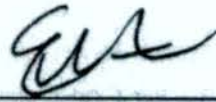

Prof. Dr. Elvan Yılmaz  
Director

I certify that this thesis satisfies the requirements as a thesis for the degree of Master of Science in Mechanical Engineering.

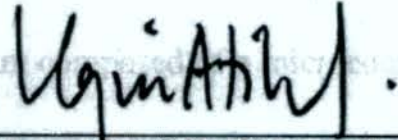

Assoc. Prof. Dr. Uğur Atikol  
Chair, Department of Mechanical Engineering

We certify that we have read this thesis and that in our opinion it is fully adequate in scope and quality as a thesis for the degree of Master of Science in Mechanical Engineering.

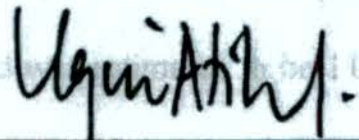

Assoc. Prof. Dr. Uğur Atikol  
Supervisor

Examining Committee

1. Prof. Dr. Hikmet Aybar
2. Assoc. Prof. Dr. Uğur Atikol
3. Assoc. Prof. Dr. Fuat Egelioglu

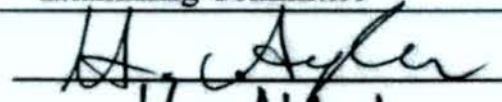
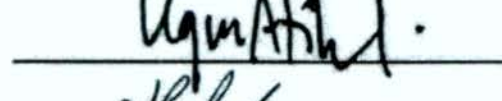
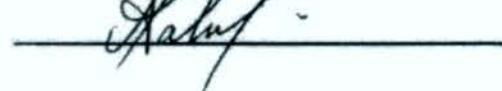
## ABSTRACT

Small wind turbines are known to generate less than 100 kW of electricity and they are used in farms, homes and small businesses for backup electricity to reduce electricity bills. The present work is concerned with the monitoring of a small scale wind charger which is mounted on the roof of the building of the department of mechanical engineering at Eastern Mediterranean University. Rutland 913 wind charger used for this work has a swept diameter of 910 mm and produces a power output up to 300Wp. A data acquisition system composed of a microcontroller and a series of resistors are used to measure the current and voltage and calculate the corresponding power and wind speed. Using a serial port, data are sent to a personal computer (PC). The data transferred to the PC are recorded to a text file using a purpose-designed program for this system. Two methods of estimating annual energy output (AEO) are introduced and compared with actual data. Data recorded are displayed as a power versus hour curves for each month. Average wind speed for the period of measurements (7 months) was obtained as 4.9 m/s and power produced at this speed was measured as 12.6W. AEO generated was estimated to be 110kWh/yr according to experimental data. By using the swept area and power curve methods, the theoretical AEO was estimated as 103.2kWh/yr and 112.21kWh/yr respectively.

**Keywords:** Small-scale wind turbine, power output, data acquisition system, microcontroller, annual energy output.

## ÖZ

Küçük rüzgar türbinleri 100 kW elektrik üreten türbinler olarak biliniyor ve evlerde ve çiftliklerde kullanılıyor. Ev ve işletmelerde elektrik depolamak için kullanılarak elektrik faturasının azalmasını sağlıyor. Yapılan iş makina mühendisliği binasının çatısı üzerine monte edilmiş küçük ölçekli şarj izleme ile ilgilidir. Bu iş için Rutland 913 modelinde türbin kullanılmıştır ve bu iş için çapı 910 mm olan türbin kullanılmıştır. Bu türbin 300 Wp bir güç üretiyor. Bir veri toplama sistemi üreten gücü ölçmek için ve rüzgarın hızını hesaplamak için kullanılır. Seri port verileri PC'ye gönderilir. Gönderilen veriler bu sistem için hazırlanmış özel bir programla text dosyasında kaydediliyor. Tahmini yıllık enerji üretimi için iki yöntem tanıtılmış ve pratik veri ile karşılaştırılmıştır. Kaydedilen bilgiler güç saat grafiği oluşturularak grafik oluşturuldu. 7 ay boyunca alınan ölçümler sonucu ortalama rüzgar hızı 4.9 m/s ve bu hızda üretilen güç 12.6 W olarak saptandı. Yıllık üretilen enerji yaklaşık olarak 110kWh/yr. Swept area methodla yıllık üretilen enerji 103.2kWh/yr ve power curve methodla da 112.21kWh/yr olarak bulundu.

**Anahtar kelimeler:** Küçük ölçekli rüzgar türbini, güç çıkışı, veri toplama sistemi, mikro işlemci, yıllık enerji üretimi.

*TO MY FAMILY*

## ACKNOWLEDGMENTS

I am very grateful to have an opportunity of working with my supervisor Assoc. Prof. Dr. Ugur Atikol who let me use his knowledge and guide me with his experience. I wish to have other projects and studies with him, in order to get benefit in my future works.

I would like to thank my dear friends Dr. Reza Abrishambaf and Ms. Farzaneh Ansary for their cooperation in designing hardware and software used in this project which was very useful and without them data taking would be very difficult and less in accuracy.

Sincerely thank other friends in ME department and people who I didn't mentioned their names and have cooperation in this project, and finally I appreciate my family who afford me for master education and gave me chance to study in Cyprus.

## TABLE OF CONTENTS

ABSTRACT.....	iii
ÖZ .....	iv
DEDICATION.....	v
ACKNOWLEDGMENTS .....	vi
LIST OF TABLES .....	ix
LIST OF FIGURES .....	x
LIST OF ABBREVIATIONS.....	xiii
1. INTRODUCTION .....	1
2. LITERATURE REVIEW .....	3
3. ANNUAL ENERGY OUTPUT ESTIMATION .....	7
3.1 wind speed measurement methods.....	7
3.2 Effect of Altitude: .....	10
3.3 Data Analysis and Output Estimating:.....	11
3.4 Method of Swept Area .....	12
3.5 Power Curve Method:.....	16
4. MEASUREMENT APPARATUS, HARDWARE AND PROGRAM .....	17
4.1 Wind Turbine .....	18
4.2 Data Acquisition Board: .....	20
4.3 Wind Turbine Monitoring Software: .....	24
5. RESULTS AND DISCUSSION .....	28
5.1 Applying swept area method: .....	29
5.1.1 Error estimation.....	30
5.2 Applying Power Curve Method:.....	30

5.2.1 Error estimation:.....	32
5.3 Economic Feasibility.....	34
6. DISCUSSION AND CONCLUSIONS.....	37
REFERENCES .....	39
APPENDICES .....	42
Appendix A: Theoretical Aspects of wind energy .....	43
A1: Power in the wind .....	43
Appendix B : Experimental Data with the Aim of Graph.....	48
Appendix C : Europe and Western Asia Wind Classifications by US Department of Energy.....	62
Appendix D : Basic Program Codes for Monitoring Software.....	64
Appendix E : Life Cycle Analysis .....	66

## LIST OF TABLES

Table 3-1 : Overall efficiency estimation .....	14
Table 3-2: Estimated annual energy output at Hub height in mWh/yr .....	15
Table 5-1: Average of data taken from each month.....	28
Table 5-2: Estimating Annual Energy Output from wind speed distribution, and power curve for Rutland WG913.....	31
Table 5-3: Parameters and results related to feasibility analysis: .....	35

## LIST OF FIGURES

Figure 2-1: Aye Khaing small-scale wind charger .....	5
Figure 2-2: Measurements instrument of Aye Khaing.....	5
Figure 2-3: Monthly generated power by combined solar and wind energy system of Hilkat Soysal and Oguz Soysal .....	6
Figure 3-1: Anemometer.....	8
Figure 3-2: Digital data logger.....	8
Figure 3-3: Effect of tower in enhancement of power output percentage .....	10
Figure 4-1: Schematic diagram of the system.....	17
Figure 4-2: Current output versus wind speed for Rutland WG913 .....	18
Figure 4-3: Rutland 913 wind charger .....	19
Figure 4-4: Rutland WG913 wind charger and dimensions .....	20
Figure 4-5: flow chart of the software .....	22
Figure 4-6: Schematic of data acquisition board .....	23
Figure 4-7: Hardware used.....	24
Figure 4-8: Designed program and preview. ....	26
Figure 4-9: Sample text file from latest data.....	27
Figure 5-1: Front view of Rutland WG913.....	29
Figure 5-2: Rutland WG913 power graph .....	31
Figure 5-3: Rutland WG913 wind speed distribution chart for 3393hr .....	31
Figure 5-4: Average power produced in 7 months .....	33
Figure 5-5: Average wind speed in 7 month.....	33
Figure 5-6: Wind speed versus Hours graph in December .....	34
Figure A-1: Theoretical power production in different rotor diameter.....	45

Figure A-1: Voltage versus Hours graph in April .....	48
Figure A-2: Current versus Hours graph in April .....	48
Figure A-3: Power versus Hours graph in April .....	49
Figure A-4: Wind speed versus Hours graph in April .....	49
Figure A-5: Voltage versus Hours graph in May.....	50
Figure A-6: Current versus Hours graph in May .....	50
Figure A-7: Power versus Hours graph in May .....	51
Figure A-8: Wind speed versus Hours graph in May .....	51
Figure A-9: Voltage versus Hours graph in June.....	52
Figure A-10: Current versus Hours graph in June .....	52
Figure A-11: Power versus Hours graph in June .....	53
Figure A-12: Wind speed versus Hours graph in June .....	53
Figure A-13: Voltage versus Hours graph in September.....	54
Figure A-14: Current versus Hours graph in September .....	54
Figure A-15: Power versus Hours graph in September .....	55
Figure A-16: Wind speed versus Hours graph in September.....	55
Figure A-17: Voltage versus Hours graph in October .....	56
Figure A-18: Current versus Hours graph in October .....	56
Figure A-19: Power versus Hours graph in October .....	57
Figure A-20: Wind speed versus Hours graph in October.....	57
Figure A-21: Voltage versus Hours graph in November .....	58
Figure A-22: Current versus Hours graph in November.....	58
Figure A-23: Power versus Hours graph in November.....	59
Figure A-24: Wind speed versus Hours graph in November.....	59
Figure A-25: Voltage versus Hours graph in December.....	60

Figure A-26: Current versus Hours graph in December .....	60
Figure A-27: Power versus Hours graph in December .....	61
Figure A-28: Wind speed versus Hours graph in December .....	61
Figure A-29: Europe and western Asia wind classifications .....	62
Figure A-30: Classes of wind power density .....	63

## LIST OF ABBREVIATIONS

AEO	Annual Energy Output
kWh	Kilowatt-Hour
MWh	Megawatt-Hour
DC	Direct Current
AC	Alternative Current
LCD	Liquid Crystal Display
IC	Integrated Circuit

# Chapter 1

## INTRODUCTION

Wind is one of the renewable natural air movements available in our environment. Wind has a lot of advantages with a few disadvantages and it does not harm water and soil and does not cause air pollution. Wind can be captured and consumed as a form of energy. The energy captured from the wind can be converted into other forms of energy. The mechanical energy of the wind turbine can be used directly, like in grain grinding or water pumping. On the other hand, energy produced by windmill can be converted in to electricity through a generator connected to the turbine shaft.

After the “Renewable Energy Law” was put into force in October 2011, in North Cyprus, the performances of small-scale wind turbines have become the subject of interest for the policy makers and investors. Since the feasibility of these types of turbines is always questioned, there is a need of collecting data during their operation under real life conditions. The Rutland 913 type charger, installed on the roof of the Mechanical Engineering Building, was used for taking measurements of current and voltage and determining the hourly wind speed for this location. Rutland 913 has a swept diameter of 910mm and it is located about 10 meters above the ground level. This turbine operates with a six bladed rotor and a high efficiency generator.

The wind speed at which Rutland WG913 starts producing electricity is 3.5 m/s (cut-in speed). The wind charger rotates itself towards the prevailing wind direction using its tail.

The energy captured by this small-scale wind turbine is converted in to electricity with the use of a small alternator. DC voltage produced can be either used directly or stored in a battery.

The present work is concerned with the use of a data acquisition system for measuring the performance of a small-scale wind charger. The data acquisition system used for this work was specifically designed and programmed for this project. With the aid of this system it will also be possible to estimate the wind speeds 3m above the M.E. building by using the current wind speed graph supplied in the user manual of the charger.

The next four chapters discuss, the literature review, system description, data acquisition system, measurements and analysis. In the second chapter data collection for wind energy will be discussed, in which ways and how these data was collected. Third chapter will be about the system used for this project including all equipments used, connections and their functions. Data acquisition system itself describing with detail information about hardware and the program will be placed in fourth chapter, and finally the last chapter will be about measurements, analysis and final results.

## Chapter 2

### LITERATURE REVIEW

In the recent years, Wind energy conversion systems have become a main point in the research of renewable energy sources.

According to Paul Gipe [1], using a kilowatt-hour meter the performance of small scale wind machine can be estimated. In order to check the instantaneous wind speed, an anemometer can be installed on the tower of wind turbine. A Simple way of testing the system is to measure the wind speed when the wind charger starts to generate electricity. In this case the anemometer should be installed near the rotor. Pual says all the measurements are only approximations, because the measured wind speed by anemometer is not the one which strikes the rotor, even when the rotor and anemometer are next to each other.

Leckie Jim et al [2], experimentally investigated small-scale wind turbines. They indicated that there was a delay between wind speed and power produced by the wind turbines. Wind turbines do not instantly follow the power curve. It takes some time to reach the steady state conditions. It is also explained that it would not be surprising if the recorded wind speeds do not match with power generation of the turbine given in the manufacturers' specifications.

An alternative way of performance measurement test is given by Marier Donald [3]. Donald conducted experiments to compare the measured power output of the turbine at various speeds with the power curve of turbines. In large wind machines a control panel is installed and one of its functions is to measure watts (power output), but small wind chargers does not have this system. Using a kilowatt-hour meter the net energy generated will be recorded. Donald used data recorded by kilowatt-hour meter and calculated power output. He also compared the energy generated with the wind turbine power graph.

In the method which Marier [3] used for measuring the performance of his 0.3kW micro wind turbine, the number of revolutions of turbine is counted in a period of time (for example 30 seconds) and using the following relation he obtained the power output.

$$P = N \times kh \times 60 \text{ min/h}$$

P = power (Wh)

kh = factor of energy that passes through the meter per revolution of the disc.(watt-hours/revolutions)

N = number of revolutions per minute

Aye Khaing Soe and Wanna Swe [4], in a performance test of their small-scale power system measured voltage by using voltmeter. With the aim of resistors they measured the current and calculate the power output. They manufactured a turbine with a swept diameter of 2m and the rated power of 212W. Figure 2-1 shows the Aye Khaing Soe and Wanna Swe's wind charger. In their work two ways of measurements was used; No-load and loaded cases. In On-load case they used

H. Soysal and O. Soysal , used combined wind and solar grid connected system for their experimental work[5]. They used a 1.8 kW wind turbine and 2kW solar panels [5]. According to their study, this system is enhanced by using both PV and wind power having a smooth power output. This combined system is adopted with seasons. In winter electricity is generated mostly from the wind but, in summer the system tends to produce electricity from the PV.

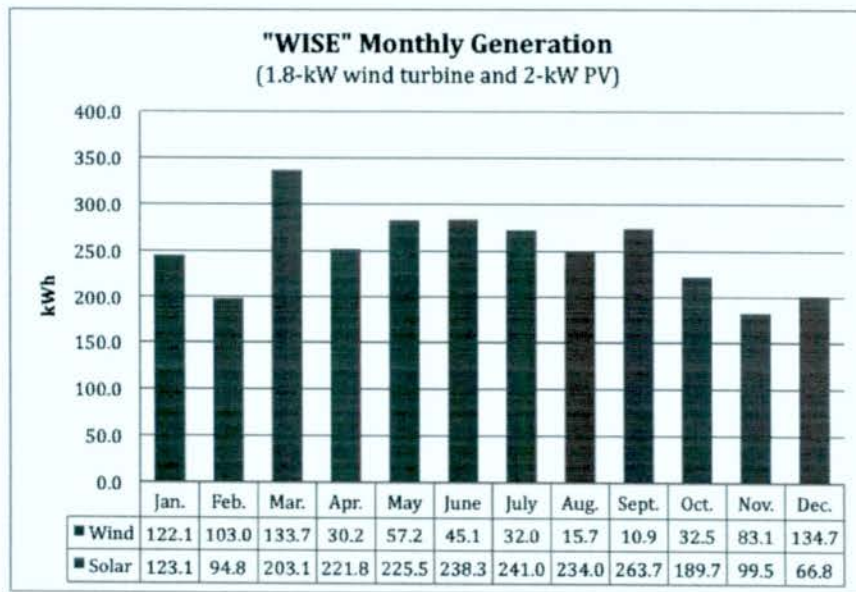

Figure 2-3: Monthly generated power by combined solar and wind energy system of Hilkat Soysal and Oguz Soysal [5]

resistors and found power output. However in No-load case they only measured Voltage and Frequency (Hz). The electricity generated from this system is used to charge a 12V battery. The energy spared in battery is used for lighting. Figure 2-2 shows the measurement system used by Khaing and Swe. They found that the Voltage can be affected when an electrical load like a resistor is loaded. So in No-load conditions the average Voltage output from turbine is slightly (around 10%) more then On-load case.



Figure 2-1: Aye Khaing small-scale wind charger [4]

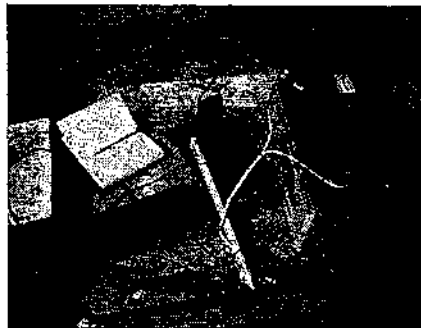

Figure 2-2: Measurements instrument of Aye Khaing [4]

## Chapter 3

### ANNUAL ENERGY OUTPUT ESTIMATION

#### 3.1 wind speed measurement methods

In order to perform a measurement of wind speed, an anemometer and a recorder is needed. The instruments to measure the wind speed are readily available and accessible. Such systems are much cheaper than those needed for solar measuring systems [6]. A wind speed measuring system is made of two main parts; an anemometer head (Figure 3-1) and a recorder (Figure 3-2). The recorder may also have a displaying measured data from the anemometer. The anemometer can also be mechanically connected to a DC generator to generate electricity. Change in DC voltage is proportional to wind speed, and then the voltage is calibrated with voltmeter. Sometimes AC alternator is used for better accuracy and measuring frequency. An anemometer with a voltmeter is not enough to calculate average wind speed; only the instantaneous wind speed can be measured using these two instruments.



Figure 3-1: Anemometer [6]



Figure 3-2: Digital data logger [7]

Like the odometer used for the cars, an accumulator counts the kilometers of wind passed the anemometer, the number of kilometers recorded is divided by elapsed time [8]. For different wind speeds there are different counters. For instance wind

speeds from 0 to 1m/s will fall in the first counter, wind speeds between 2 and 3m/s will fall in to second and so on. Each counter is adjusted to count hours of different wind speed range. By using this method it would be possible to check how many hours in a year the wind blows with the speed of 2 to 3m/s. The annual speed distribution can be found using data taken from accumulator. The speed distribution will be useful to calculate Annual Energy Output of any turbine which has power curve. Accumulators do not help us to find instantaneous wind speed. Data loggers were introduced to obtain instantaneous wind speed in any time. The wind speed is measured and recorded in a memory every second. Recorded data is transferred to a personal computer. Wind speed distribution chart can be obtained from PC.

Data loggers can be used for small-scale wind systems. The percentage of error would be very low by using a data logger because; all the data are taken and recorded automatically. In this study a computer and a data acquisition system is used to calculate the wind speed by measuring the instantaneous power output from a small-scale wind turbine. Since wind direction does not affect the measurement for wind speed, data taken from wind charger and anemometer can not be distinguished. Because Rutland WG913 wind charger adopts itself with direction of wind. Tail vane puts the turbine in direction of the wind.

### 3.2 Effect of Altitude:

Wind speed tends to be higher on the top of a ridge or hill, so it is better to install the wind turbine at hilly locations (check Appendix A for more information). The same amount of power should not be expected from a wind turbine to produce all the time; power generation depends on the wind speed. For example if the wind speed varies by 10% the power produced by wind turbine can vary up to 25% [9]. Another important factor which affects the power output is height of its tower. It has been recommended [9] that towers should be 24-37 m high. Installing a wind turbine on a tower that is too short is like installing a solar panel in a shady area. Figure 3-3 shows the increase in power output when the height of the tower increases [9].

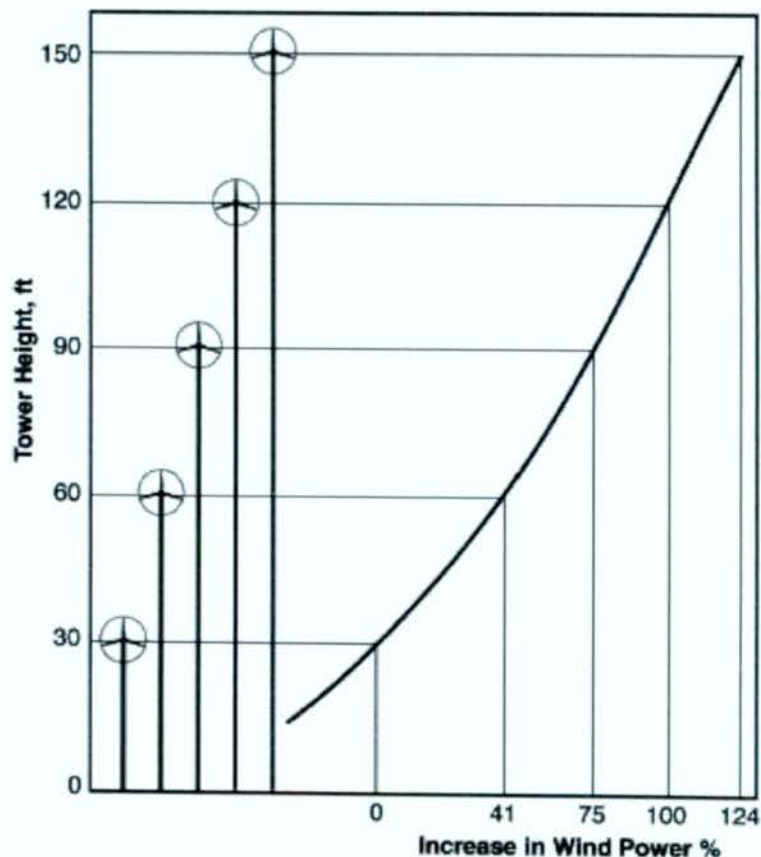

Figure 3-3: Effect of tower in enhancement of power output percentage [9]

### **3.3 Data Analysis and Output Estimating:**

The average wind speed can vary from year to year as much as 25% [9]. Even one year data may not be enough for determining the average wind speed accurately. But one year average is suggested by scientists, data obtained from one year measurements can be compared with the nearest airport data which were collected during a long period. With the aim of this comparison the probability of increasing or decreasing the wind speed in the future can be checked. Although the nearest airport will not always be the best reference, it can be assumed as good source.

Another method of comparison is introduced by Pual Gipe[1] and it gives the ratio between two sites by testing the degree of correlation. This method is done by drawing a mid line between two curves. But these data and numbers do not show the whole picture, since the power density should be calculated.

By estimating the annual energy output (AEO), economical feasibility can be calculated for this project. Even for a small wind system these calculations should be done. A micro wind system costs about \$1500, not much more than an anemometer and an odometer. Although it is not very accurate, easy and cheap way to measure the wind speed, it works. What is gained is the energy output of the wind system and the quantity of the energy, exactly what we are looking for it. What we are looking for is how well a small wind charger is working at our site. Using a small-scale wind system can help us to use larger wind machines; In order to make some analysis the performance of the wind turbine should be estimated. For instance, if it is found that a 6kW turbine will meet our needs first; by installing a 0.4kW micro turbine the wind quality can be obtained. Then, if it is calculated and proved that the wind works well

at the site of experiment , the size of the turbine can be increased again to a 6kW machine. It would be more economical if the tower and foundation are built for a 6kW wind turbine.

When the calculation of AEO is completed, the feasibility analysis and wind turbine selection can be processed according to the energy needed. One way of estimating output is, the Swept Area Technique. If the wind speed and diameter of rotor is known, AEO can easily be calculated. Another method is to have wind speed distribution at the selected site and use the power curve for the wind turbine which is going to be installed. A third approach is to use the manufacturer's estimate for typical wind regimes.

### **3.4 Method of Swept Area**

This method is used to find the energy in the wind. What captures the wind is the rotor of the turbine. The generator, tower, transmission and other parts do not specify the energy generated. These parts are important in energy generating but they do not have direct effect on power produced. Unlike other components the rotor gives direct information about the capacity of the turbine.

The swept area is calculated by using the following equation:

$$A = \pi R^2 \quad (3-1)$$

Where  $\pi$  is 3.14 and R is the radius of the swept area. And power output is estimated by Equation 3-2:

$$P = p \times A \quad (3-2)$$

Where P (W) is the ideal power generated, p is the power density ( $\text{W}/\text{m}^2$ ) and A is the swept area ( $\text{m}^2$ ). For example, if the annual average power density of  $250 \text{ W}/\text{m}^2$  and 1m swept diameter is assumed, by using Equation 3-1 and Equation 3-2; power can be calculated to be 195W.

The amount of energy consumed is the product of time and power, therefore

$$E = \int p \cdot dt \quad (3-3)$$

Where E is the energy consumed over a defined period of time, if the power generated is constant, then

$$E = P \times t \quad (3-4)$$

For example, if the power generated P is 195W, then the Annual Energy Output can be calculated. There are 8760 hours in a year, if there is 195W of energy passes through the rotor annually then according to the Equation 3-4, energy can be calculated to be 1708 kWh/yr.

This is not what the wind charger produces because it can't capture all of this energy. Albert Betz was a German scientist that gives the reason. According to his theory the portion of the wind that keep moving through the rotor can not be captured 100 %. According to Betz the maximum limit of energy that can be obtained from a wind turbine is 59.3% of total energy. In reality, wind turbine rotors convert much less

than the Betz limit wind into energy. The best designed rotors can convert up to 40% of energy available. Even usable energy is much less because a lot of energy is lost in generators, transmissions and convertors. Generator efficiency can be more than 90% but sometimes they are partially loaded so the efficiency suffers as a result. In Table 3-1 overall efficiency of a wind turbine is calculated using those numbers.

Table 3-1 : Overall efficiency estimation[10]

Rotor Efficiency	Transmission	Generator	Yawing and Gusts	Overall
40% ×	90% ×	90% ×	90% =	29%

In reality wind turbines capture 12-30% of the energy in the wind [10]. Wind turbines are designed for specific purposes in different wind conditions. Small scale wind turbines generally convert 25-30% of the total energy. In wind sites where average wind speed is below 5.5 m/s, the efficiency of small scale wind turbines tends to be higher [10].

To calculate the AEO of the wind turbine, the following steps should be done:

Power density P should be known at the height where the wind machine will operate.

Swept area A should be given.

Approximate value for efficiency should be given.

All calculations should be done based on 360 days period.

So:

$$AEO = P/A \times A \times \% \text{efficiency} \times 8760 \text{ h/yr} \quad (3-5)$$

In Table 3-2 annual energy output is available in terms of mWh/yr. If the rotor diameter and average wind speed are given, the other specifications of the wind turbine can be found from the table. The assumed efficiencies have been obtained from a survey of manufacturers of wind turbines. These numbers show approximate quantity and they can be changed from turbine to turbine. Power density can be calculated using Equation 3-6:

$$P/A = \frac{1}{2} \rho v^3 \quad (3-6)$$

Table 3-2: Estimated annual energy output at Hub height in mWh/yr [10]

Average Speed (m/s)	Power Density (W/m <sup>2</sup> )	Total Effic	Rotor Diameter (m)							
			1	1.5	2	3	4	5	6	7
4.0	75	0.28	0.1	0.3	0.6	1.3	2.3	3.6	5.2	7.1
4.5	110	0.28	0.2	0.5	0.8	1.9	3.4	5.3	7.6	10
5.0	150	0.25	0.3	0.6	1	2.3	4.1	6.5	9.3	13
5.5	190	0.25	0.3	0.7	1.3	2.9	5.2	8.2	12	16
6.0	250	0.21	0.4	0.8	1.4	3.3	5.8	9	13	18
6.5	320	0.19	0.4	0.9	1.7	3.8	6.7	10	15	20
7.0	400	0.16	0.4	1	1.8	4	7	11	16	22
7.5	490	0.15	0.5	1.1	2	4.6	8.1	13	18	25
8.0	600	0.12	0.5	1.1	2	4.5	7.9	12	18	24
8.5	720	0.12	0.6	1.3	2.4	5.3	9.5	15	21	29
9.0	850	0.12	0.7	1.6	2.8	6.3	11	18	25	34

If the average wind speed is unknown, the power density can be estimated by finding the location in wind speed distribution maps. If the value of the power density is known, we can estimate how much energy a wind turbine will generate.

### **3.5 Power Curve Method:**

With this method the AEO can be calculated by using the wind speed distribution chart for selected site and the turbine power curve given by manufacturers. This technique is used by meteorologists to determine the AEO of a wind turbine. Eventually, by matching the power curve and the wind speed distribution chart, the calculations of the total power generation by turbine can be done by using corresponding wind speed range. Sum of the energy generated in all wind speed range will be AEO.

## Chapter 4

### MEASUREMENT APPARATUS, HARDWARE AND WIND TURBINE MONITORING PROGRAM

This system is made up four main parts: a wind charger, personal computer, data acquisition system and connecting cables. Figure 4-1 shows the schematic diagram of our system. Power output is connected to an electronic apparatus which measures the power produced. The measured power is converted to data language and data about power will be recorded by using a PC.

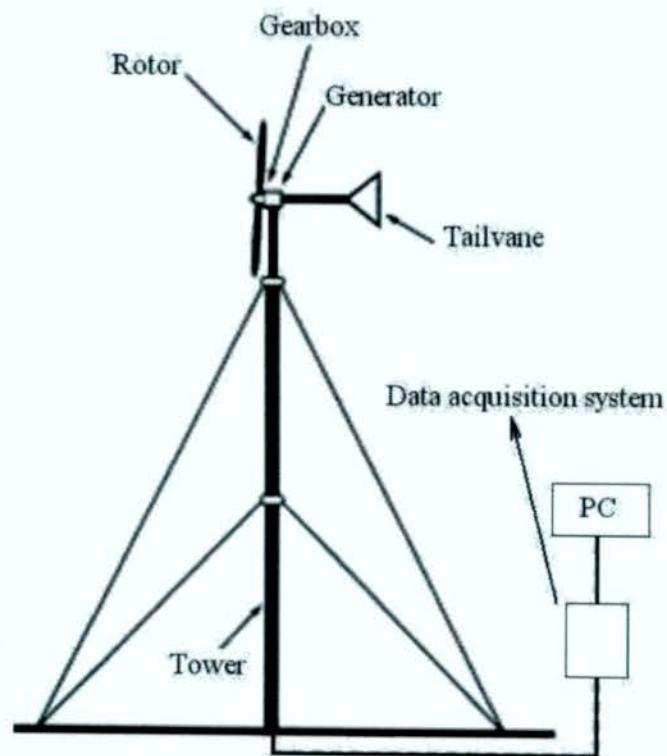

Figure 4-1: Schematic diagram of the system [9]

## 4.1 Wind Turbine

Wind speed and electricity generated are directly related to each other; as the wind speed is increased, electricity produced is increased. The small-scale wind charger generates 0-12V DC. Current produced by the wind charger is plotted against the wind speed in Figure 4-2 [11].

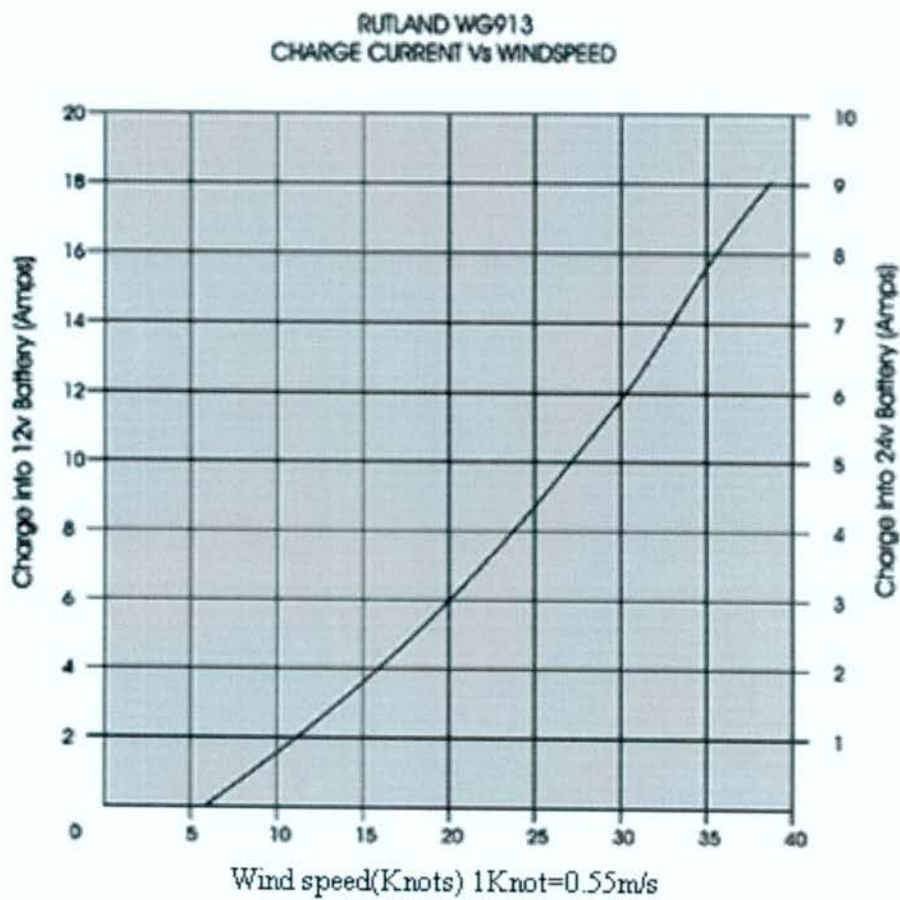

Figure 4-2: Current output versus wind speed for Rutland WG913 [11]

Swept diameter of this wind charger is 910mm with a six bladed rotor. This small-scale turbine has a weight of 10.5Kg and it is mounted on a 3m long tower located on

the roof of the mechanical engineering building as can be seen in Figure 4-3. The total height of the turbine from ground level is around 12m. The cut-in speed of this turbine is 3.5m/s. Rutland WG913 generates 24W and 90W at wind speeds of 5.5m/s and 10.5m/s respectively. Maximum power output of this turbine is 300W [11]. The total length of the turbine with its vane tail is 608mm. Technical drawings are available in two dimensional with front and side views in Figure 4-4[11].



Figure 4-3: Rutland 913 wind charger

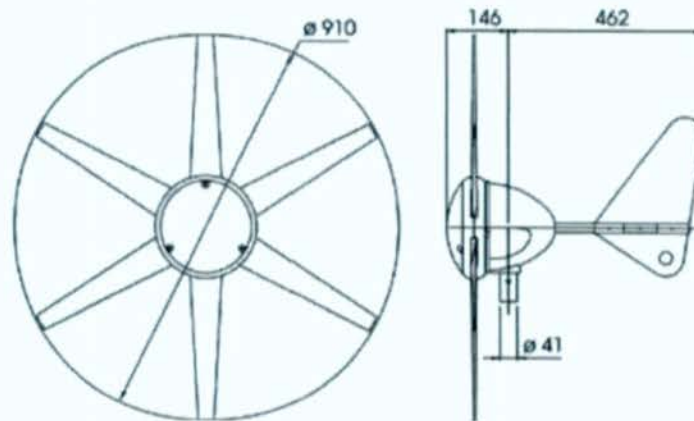

Figure 4-4: Rutland WG913 wind charger and dimensions [11]

#### 4.2 Data Acquisition Board:

Data acquisition board is the measurement apparatus used in this project specially designed and programmed for our investigation; it can measure from 0 to 20 voltages with very high accuracy up to  $\pm 10^{-5}$ . Input of this electronic board is power output of the Rutland WG913 wind turbine and outputs are data about voltage, current, power and wind speed. This board is made of one micro controller, voltage adopter, resistors and one LCD. The micro controller is an interface between turbine and computer; the voltage coming from the turbine is decreased by resistors and measured by controller; at the same time current, power and wind speed is calculated by this device. The instantaneous current and voltage will be displayed on the LCD and the same data will be sent to a PC before passing the voltage adopter.

Voltage adopter is an IC which increases the voltage from 5 to 12, in order to be received by serial port of PC. In another word this data acquisition board is an interface between turbine and PC. The duty of this hardware is to measure the power produced by wind turbine, at the same time sent it to computer as a data. PC receives

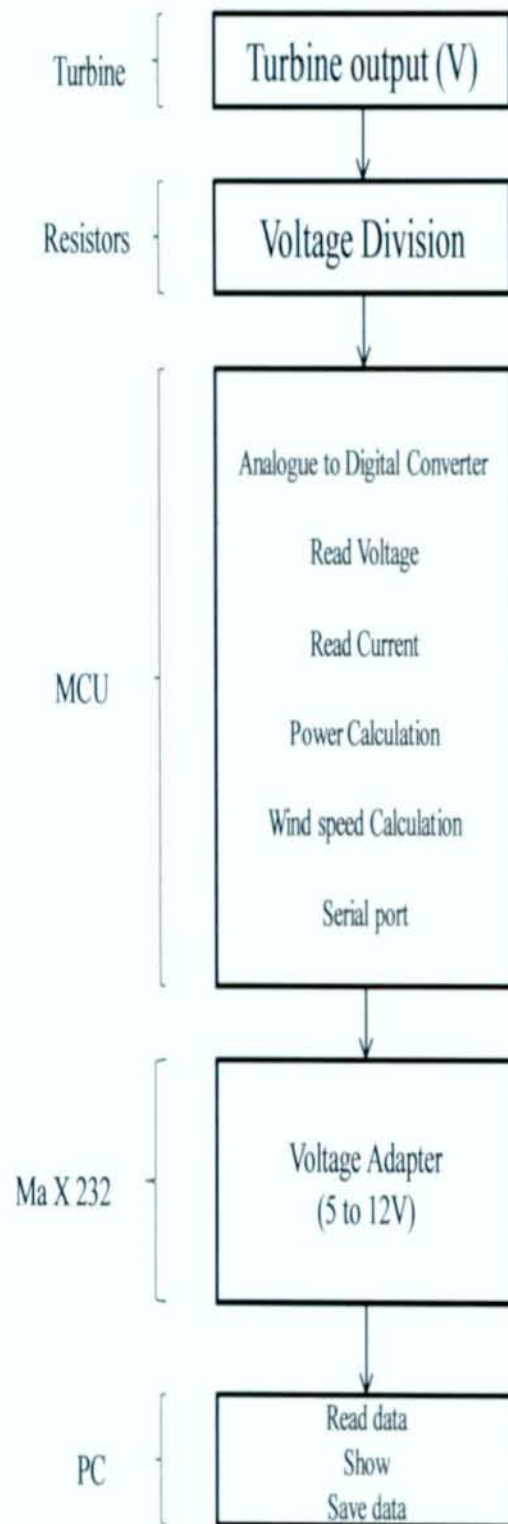

Figure 4-5: flow chart of the software

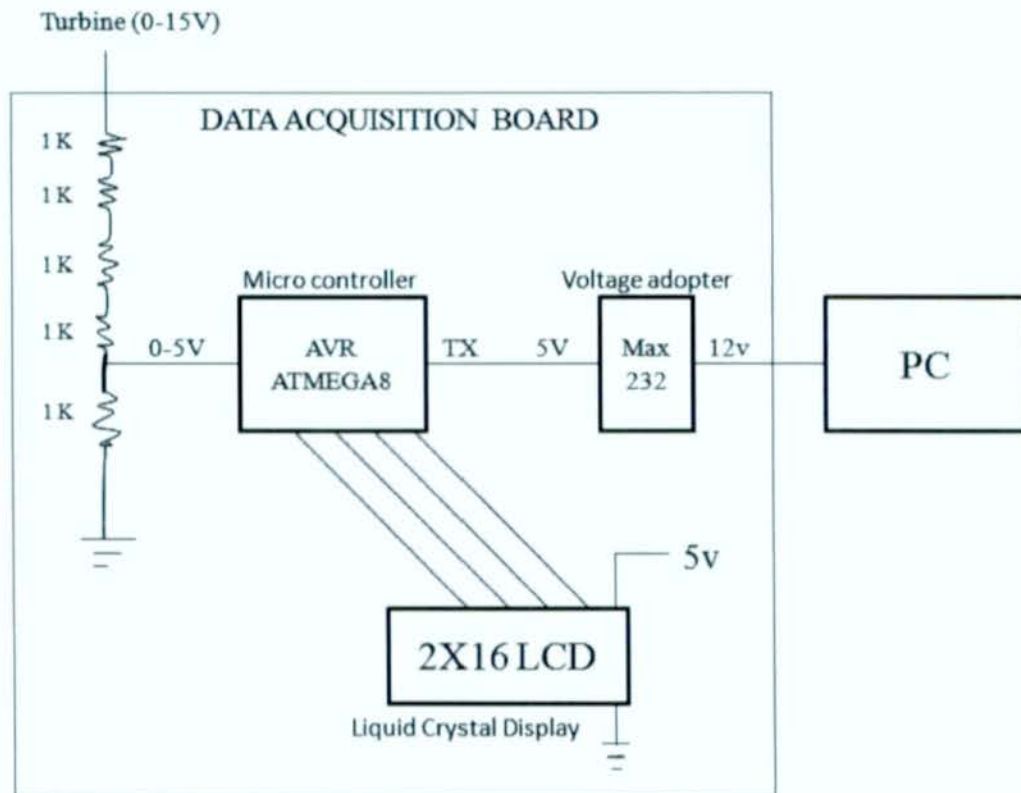

Figure 4-6: Schematic of data acquisition board

Figure 4-6 shows the schematic of data acquisition board. There are total 4 main components installed on this board. They are connected together with wire. The voltage output of the turbine after crossing the resistors comes to AVR ATMEGA8 micro controller; there is an analog to digital converter inside this micro controller because signals should be converted to digital ones first. All the calculations involving voltage, current, power and wind speed are done in this micro controller which is programmed at the beginning. There are two out let ports from this unit, port A and port B. Data sent from port B is received by digital 2×16 LDC. Instantaneous voltage and current are displayed on LCD. Data from port A are sent to 5-12V voltage adopter; voltage will be increased from 5 to 12V in this unit in

order to be recognized by computer. Figure 4-7 shows our data acquisition board in operation.

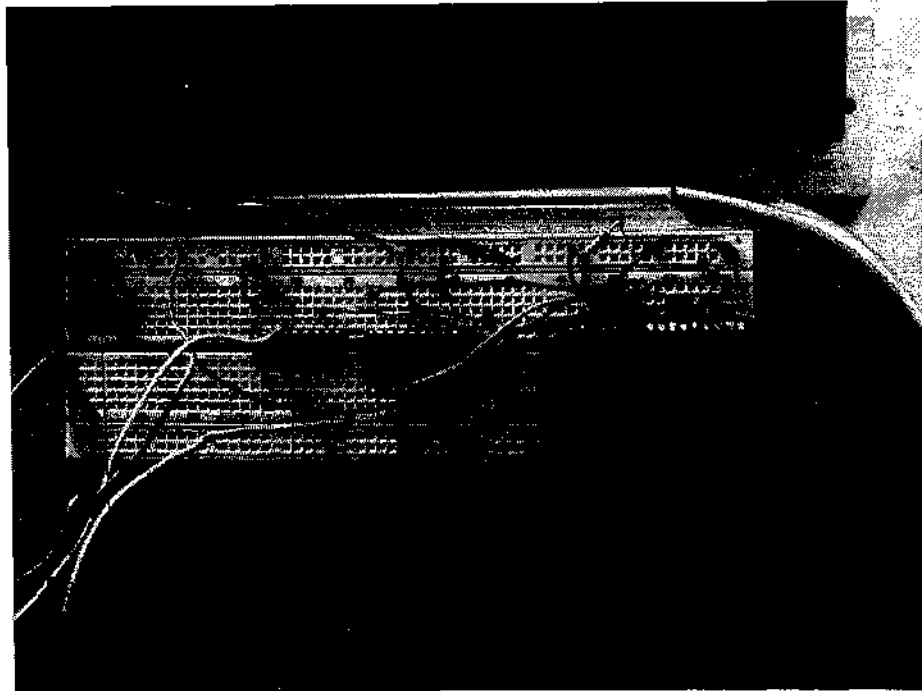

Figure 40-7: Hardware used

### **4.3 Wind Turbine Monitoring Software:**

Monitoring and recording is carried with the aim of software. The software is custom designed and developed by Reza Abrishambaf (PhD student in EE department) according to the hardware output; you can check Appendix D for program codes. Data taken from the hardware is read every 2 seconds and is recorded every 1 hour. Power curve of the turbine is defined for the program, when the program calculates the power produced at the same time it computes the corresponding wind speed from the curve. Power curve of the turbine is given as a function; where Y is power and X is wind speed, the program substitute instantaneous power produced to the function and

it finds the wind speed. All data are written in a selected text file on the desktop of the PC and they will be saved every 1 hour. So after 24 hours 24 groups of data is obtained, including date, time, wind speed, voltage, power and current which is recorded by program.

The following linear equation is used to calculate the wind speed respect to voltage output of the wind turbine:

$$Y = 1.058201X - 3.9841$$

Where X is wind speed (m/s) and Y is Amps when the turbine is charging a 12V battery. This equation is extracted from performance curve of the wind turbine given by manufacturers. However the curve is not linear, the best line is drawn and the linear equation of the line is found. In Figure 4-8 the window of the software can be seen.

Following steps should be done to run the program:

Install the program

Open the program

Create a Text file on desktop

Click on choose file and select the created Text file in previous step

Click on connect and don't close the program

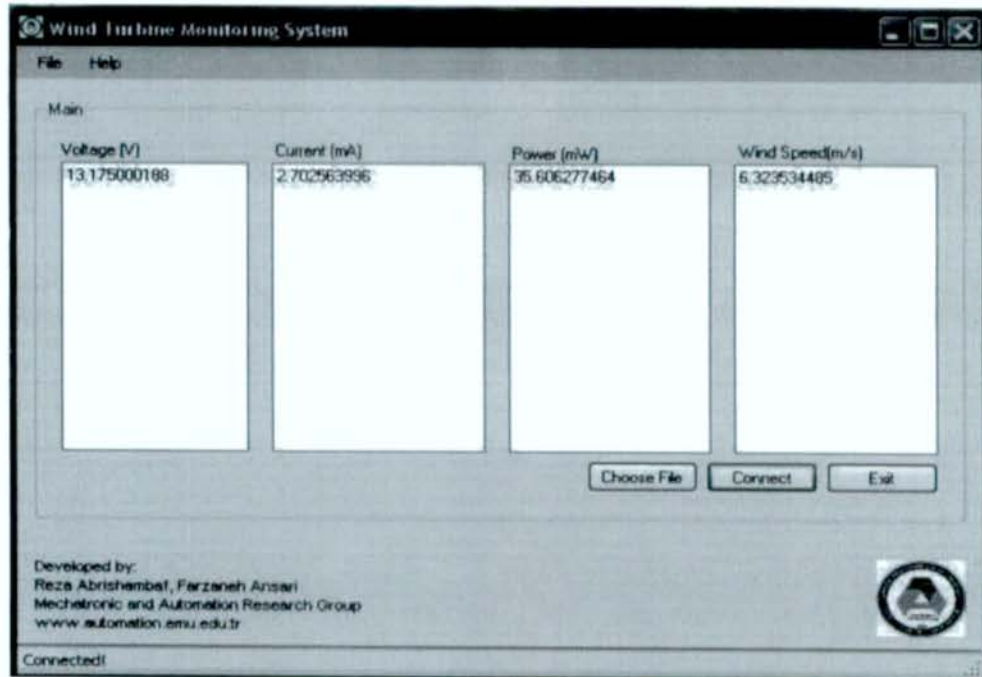

Figure 4-8: Designed program and preview.

The instantaneous voltage, current, power and wind speed can be seen on the top of each column (see Figure 4-9), when the program is connected to the hardware.

The data will be recorded every one hour in the selected text document. A sample of text file and last data can be seen in the Figure 4-9.

```
data1 Notepad
File Edit Format View Help
591069 Power: 0.549350201785557 wind Speed: 3.96231885052111 12/29/2011 4:37:09 AM
55760922223 Power: 0.0538032472155555 wind Speed: 3.84714185147111 12/29/2011 5:39:44 AM
44365799997 Power: 0.0297700562333332 wind Speed: 3.84184868610112 12/29/2011 6:42:15 AM
76844199997 Power: 0.0294937034455554 wind Speed: 3.84171944683 12/29/2011 7:44:44 AM
004184445 Power: 5.53609347422555 wind Speed: 4.46256094466555 12/29/2011 8:47:18 AM
361572224 Power: 1.57071047084221 wind Speed: 4.05666821261778 12/29/2011 9:49:55 AM
431695556 Power: 0.941919956735556 wind Speed: 3.98629119445 12/29/2011 10:52:30 AM
96145667 Power: 12.2808537633256 wind Speed: 5.18889250704222 12/29/2011 11:55:15 AM
11124222 Power: 14.55800116543 wind Speed: 5.32402496449223 12/29/2011 12:57:59 PM
15293778 Power: 19.4672714056145 wind Speed: 5.62305457225888 12/29/2011 2:00:45 PM
58371667 Power: 21.3354155628778 wind Speed: 5.72289624006333 12/29/2011 3:03:32 PM
64197 Power: 23.8357406731133 wind Speed: 5.84260715648666 12/29/2011 4:06:20 PM
0440889 Power: 20.9922950191445 wind Speed: 5.70285466995556 12/29/2011 5:09:07 PM
9656556 Power: 20.7027820208712 wind Speed: 5.68315233763556 12/29/2011 6:11:53 PM
22622667 Power: 26.4569178870189 wind Speed: 5.95284114850334 12/29/2011 7:14:39 PM
77087889 Power: 25.1460443404634 wind Speed: 5.89818185389554 12/29/2011 8:17:25 PM
41727333 Power: 26.8550992635078 wind Speed: 5.97229038465223 12/29/2011 9:20:10 PM
01140445 Power: 29.6599538531089 wind Speed: 6.08917433745778 12/29/2011 10:22:56 PM
35858889 Power: 31.04008152314 wind Speed: 6.14816820674445 12/29/2011 11:25:42 PM
46166111 Power: 29.1508206721267 wind Speed: 6.06176123418224 12/30/2011 12:28:26 AM
22531667 Power: 23.1290177151467 wind Speed: 5.79946555726556 12/30/2011 1:31:11 AM
66626445 Power: 15.6328840372869 wind Speed: 5.40516044723778 12/30/2011 2:33:52 AM
88354 Power: 28.47611839034 wind Speed: 5.94007939972778 12/30/2011 3:36:35 AM
27506111 Power: 37.5417057454022 wind Speed: 6.38607678350224 12/30/2011 4:39:19 AM
34751445 Power: 37.2560999119678 wind Speed: 6.37830136822333 12/30/2011 5:42:03 AM
51284555 Power: 37.6222691474245 wind Speed: 6.39161753117667 12/30/2011 6:44:49 AM
11534 Power: 34.5745019753466 wind Speed: 6.28341364119111 12/30/2011 7:47:34 AM
92058111 Power: 32.7685234291433 wind Speed: 6.21625132309777 12/30/2011 8:50:19 AM
81051778 Power: 34.3547474013122 wind Speed: 6.27345209655556 12/30/2011 9:53:06 AM
```

Figure 4-9: Sample text file from latest data

## Chapter 5

### RESULTS AND DISCUSSION

In chapter 4 two methods for estimating AEO were introduced. In this chapter these two methods are applied and compared with actual power generated by Rutland WG913 wind turbine. Average power output in 3393hr of measurement is calculated to be 12.6W. Constant average power of 12.6W for a period of 1 year is assumed for the estimation of AEO. Table 5-1 is a brief display of data taken in 7 months. "TOTAL AVERAGE" shows the average of all data in 7 months.

Table 5-1: Average of data taken from each month

	Voltage (V)	Current (A)	Power (w)	Wind Speed (m/s)
April	6.3825163	1.3092341	13.3380521	5.006836265
May	6.7001101	1.3743815	14.9653923	5.068400666
June	6.9306094	1.4216634	15.5333616	5.113082079
July	No data	No data	No data	No data
August	No data	No data	No data	No data
September	5.2785031	1.0827698	9.46905469	4.792827313
October	5.5735697	1.1432963	11.9001917	4.850024899
November	5.9326308	1.2169499	13.1503333	4.919627579
December	4.9708824	1.0196682	9.88808581	4.733196147
TOTAL AVERAGE	5.9669	1.22399	12.606*	4.926

\*Based on experimental data, estimated AEO = power  $\times$  1year = 12.606W  $\times$  8760hr = 110.42 kWh/yr

The maximum recorded wind speed was 6.6m/s. It does not mean that the wind speed does not exceed 6.6m/s during one year. Each group of data includes voltage, current, power wind speed time and date. One group of recorded data is the average of data taken in one hour. Therefore, 6.6m/s maximum wind speed is the average of the wind speed in one hour and it is not instantaneous wind speed.

### 5.1 Applying swept area method:

The swept area (A) can be evaluated from the radius R, which is half of the diameter and approximately equal to the length of one blade (See Figure 5-1), using Equation 3-1, A can be evaluated:

$$A = \pi R^2 = \pi(0.910/2)^2 = 0.65 \text{ m}^2$$

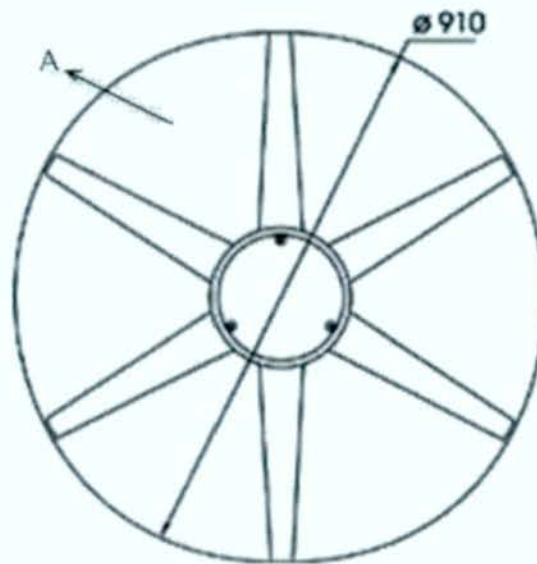

Figure 5-1: Front view of Rutland WG913

Using swept area method, power density should be estimated. To calculate power density wind speed is needed. According to Table 5-1 average wind speed (s) in 7 months was measured to be 4.926m/s, assuming average wind speed does not change during 1 year measurement.  $\rho$  is air density at sea level at 15°C.

$$P/A = \frac{1}{2} \rho v^3 = 0.6125 \text{ s}^3 = 0.6125 \times 4.926^3 = 72.502 \text{ W/m}^2$$

Now AEO can be evaluated. According to Table 3-2, for our turbine 25% efficiency is estimated.

$$\text{AEO} = 72.502 \text{ W/m}^2 \times 0.65 \text{ m}^2 \times 25\% \times 8760 \text{ h/yr}$$

$$\text{AEO} = 103.206 \text{ kWh/yr}$$

### 5.1.1 Error estimation

Estimated AEO obtained from experimental data is given to be 110.42kWh/yr. On the other hand, using swept area method AEO is found to be 103.2kWh/yr.

$$\% \text{ Error} = \frac{110.42 - 103.2}{110.42} \times 100 = \pm 6.53\%$$

### 5.2 Applying Power Curve Method:

Each wind turbine's performance is defined by a power curve which shows the power (W) generated versus wind speed (m/s). Rutland WG913 power curve is given in Figure 5-2; this graph is sketched by using one month data in different wind speeds with corresponding power output. This curve is not given by manufacturers, the only given information is voltage and wind speed relation (Figure 4-2), which

does not verify power. The power produced was measured by our monitoring system. Figure 5-2 is the power curve obtained by various power outputs and various wind speed. Each point is one data, the junction these points make this curve.

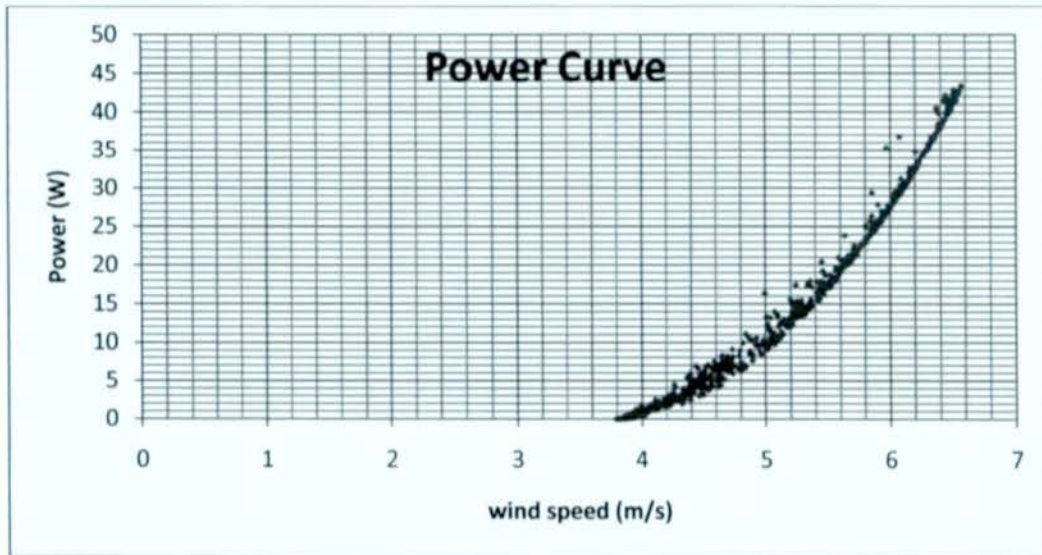

Figure 5-2: Rutland WG913 power graph

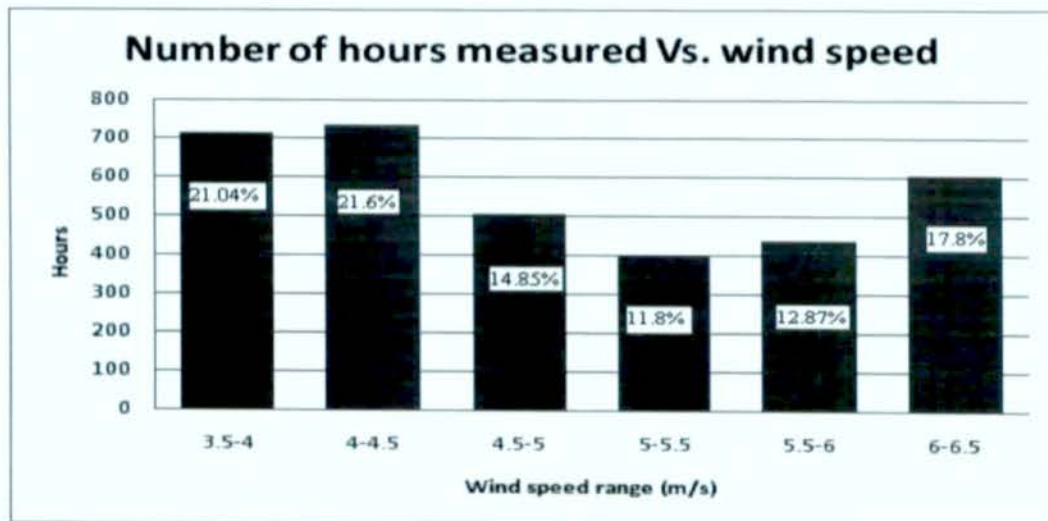

Figure 5-3: Rutland WG913 wind speed distribution chart for 3393hr

Table 5-2: Estimating Annual Energy Output from wind speed distribution, and power curve for Rutland WG913.

wind speed range (m/s)	Instantaneous power (W)	hr/3393hr	%/year	Hours/year	Energy kWh/yr
3.5-4	1	714	21.04	1843.1	1.84
4-4.5	3	733	21.6	1892.1	5.67
4.5-5	8	504	14.85	1300	10.4
5-5.5	14	401	11.81	1034.5	14.5
5.5-6	22.5	437	12.87	1127	25.3
6-6.5	35	604	17.8	1559.2	54.5
TOTAL		3393	100	8760hr	AEO=112.21

There are totally 3394 hours of data available from our measurement period. In Figure 5-3 total time of measurement is divided to 6 categories as it is shown. Each category specifies a wind speed range, in which turbine generates power. Wind speed distribution diagram helps us to find hours of operation in different wind speed range, so the speed in which our wind turbine will operate more economically can be decided. Moreover using the performance curve of other turbines there will be possible to select the required wind turbine, at this stage the performance curve of new turbine is distinguished with operation hours and decide in which speed the turbine will generate more electricity.

### 5.2.1 Error estimation:

Experimentally estimated AEO is 110.42kWh/yr as it was discussed before, and AEO computed by using the power curve method is 112.21kWh/yr.

$$\% \text{ Error} = \frac{112.21 - 110.42}{110.42} \times 100 = \pm 1.62\%$$

The average power produced in each month of measurement is shown in Figure 5-4. It was not possible to take measurements for July and August due to shortage of time. If the Figure 5-4 and 5-5 are studied, it can be easily recognized that, even a small change in wind speed can have a large effect on the power output. This is because of the power law, which states that power output is a cubic function of wind

speed (see Appendix A for more information) therefore, these two figures verify that wind speed and power have parabolic relations.

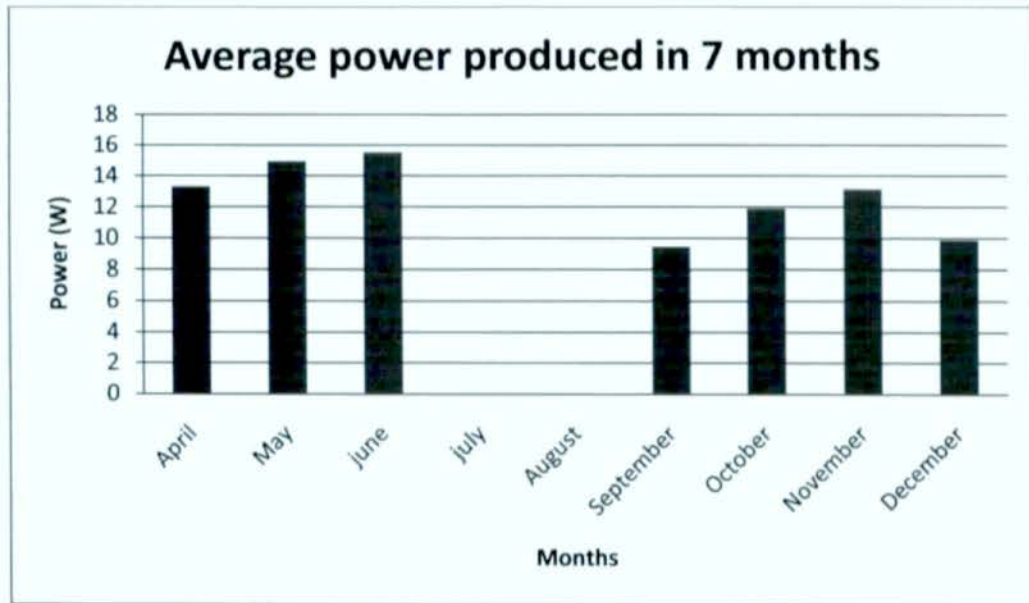

Figure 5-4: Average power produced in 7 months

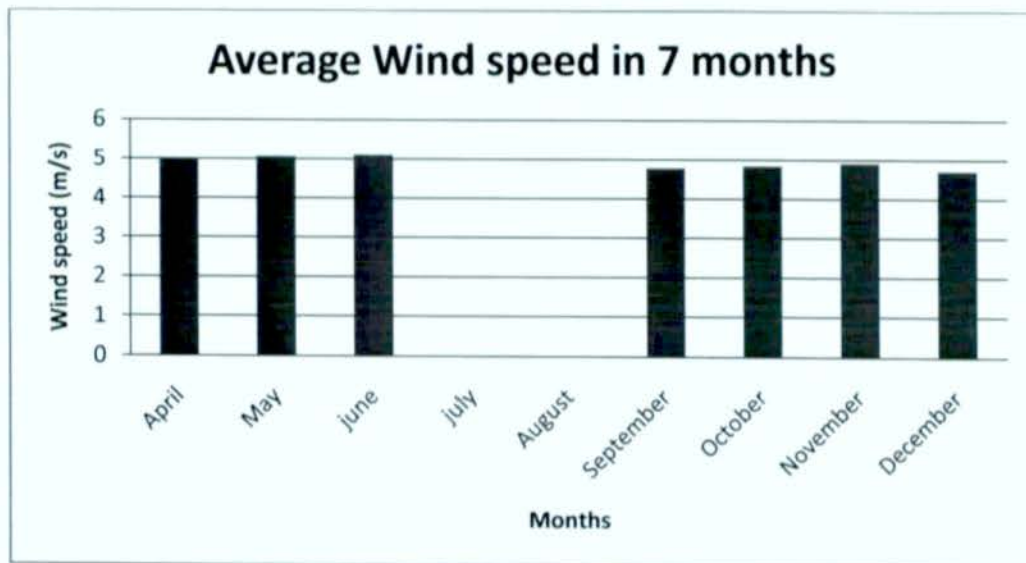

Figure 5-5: Average wind speed in 7 month

Data obtained from 7 months measurement are shown in Appendix B as a graph of time versus wind speed. The graph of time versus wind speed for December 2011 is shown below. Power, current voltage and wind speed graphs of all 7 months are available in Appendix B.

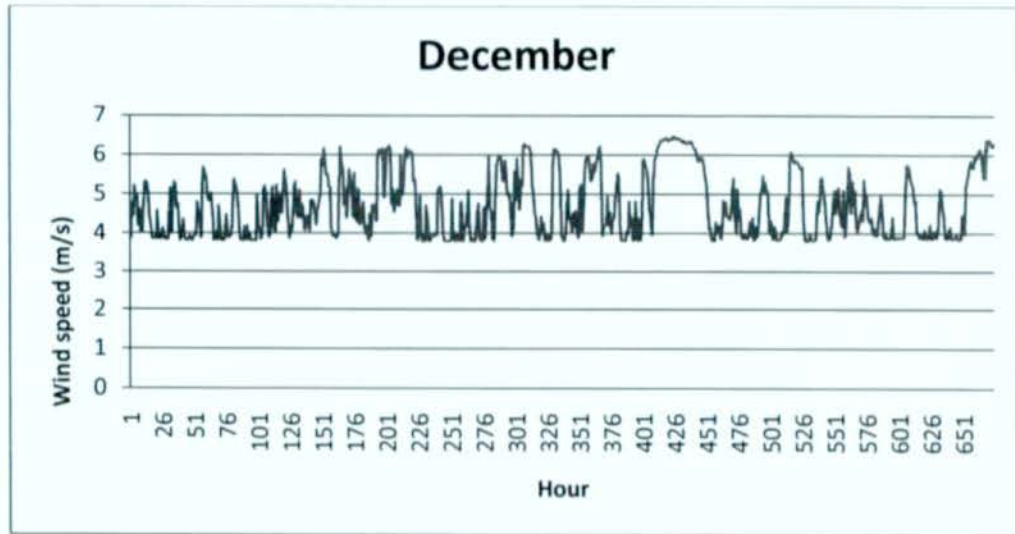

Figure 5-6: Wind speed versus Hours graph in December

### 5.3 Economic Feasibility

Economical analysis is the unique approach of measuring economic feasibility of a project. These evaluations should be done by considering the value of project and time value of money. The value of the project is expressed as present value (PV) of the investments and savings during the life-cycle of the project. The economical performance measures take account of net present value (NPV), saving to investment ratio (SIR), internal rate of return (IRR) and simple pay back. The equations are given as follows:

$$NPV = \sum PV \text{ Annual savings} - \sum PV \text{ Life cycle investments} \quad (5-1)$$

$$SIR = \frac{\sum PV \text{ Annual savings}}{\sum PV \text{ Life cycle investments}} \quad (5-2)$$

$$IRR = \text{Discount rate, where } SIR = 1, \text{ or } NPV = 0 \quad (5-3)$$

$$\text{Simple pay back} = \frac{\text{Initial investment}}{\text{Annual savings}} \quad (5-4)$$

For simple pay back calculation the time value of money does not take into account. Simple pay back should not give results more than one year; otherwise it would not be a meaningful calculation. AEO of Rutland WG913 was estimated as 110.4 kWh/yr. By considering 0.32 \$/kWh of electricity price in North Cyprus, the total amount of money saved annually can be calculated. Multiplication of AEO and price of electricity gives us total annual saving to be 35\$. The price of Rutland WG913 is equal to 700\$ (initial cost). The analysis period is taken to be 15 years. Residual value and discount rate was assumed as 200\$ and 7% respectively.

By using the available parameters and corresponding equations mentioned to calculate NPV, SIR, IRR and simple pay back economical analysis is done. The results are shown in Table 5-3:

Table 5-3: Parameters and results related to feasibility analysis:

Old costs (\$)	0
New costs (\$)	0
Discount rate (%)	7
Analysis period (Years)	15
Residual value (\$)	200
Annual saving (\$)	35
Initial cost (\$)	700
Net present value (\$)	-309
Savings-to-investment ratio	0.5
internal rate of return	0.0

Savings-to-investment ratio is calculated to be -309\$ and this project is not economically feasible since a negative number is obtained. Appendix E is the excel program used for economical feasibility analysis.

If the Annual saving is increased to 69\$, the project would be economically feasible. In this case AEO should be more than 220kWh/yr. Average power output of the wind turbine should exceed 25.5W. According to turbine power curve the average wind speed of 5.9m/s is needed to produce this much energy. By using Figure 3-3, If the height of the turbine is increased by 5 to 7 meters, most probably this much energy can be captured. Another way is to move the wind turbine to a better place like a hilly area. There are a lot of buildings and trees in the current location of the wind turbine which prevent wind to strike the turbine directly.

## Chapter 6

### DISCUSSION AND CONCLUSIONS

According to the Pacific Northwest Laboratory of the U. S. Department of Energy, Cyprus was given class 4 in wind power density (Check Appendix C for other classes). In this class, average wind speed measured at 10m altitude is given to be between 5.6 and 6 m/s which are measured at 10 meter altitude. If the altitude is increased up to 50 meters there would be 7 to 7.5 m/s wind speed which are very ideal to install large-scale wind turbines.

The average wind speed value of 4.9m/s was measured in 7 months measurement in this work. However in the wind speed potential map given by US Department of Energy, average wind speed at 10m altitude is given to be 5.6 to 6m/s (See Appendix C). In this map each region is specified by a number. The number on each country indicates the wind class of that region. According to this the wind class of North Cyprus is 4. The average wind speed measured in this work is approximately 20% less than the speed given by potential map for North Cyprus. This is due to the location and the height of the wind charger. The wind turbine is mounted at 3m above the ME building which below the level of trees and CL building. These conditions prevent wind to strike directly to the wind charger. Increasing the altitude of the wind charger will definitely enhance the power rating.

The results show that the average power generated by Rutland WG913 wind turbine is not much different than those of estimated by using the power curve method and method of swept area.

Objectives of the present work were largely satisfied since, data acquisition system was designed and specifically used to measure and record all desired data. Measurements were made with very high quality and accuracy during 7 months. Current, voltage, power and wind speed were measured and recorded every one hour. Two methods of AEO estimation were applied to find theoretical AEO. Theoretical AEO were calculated with very low percentage of error. By using economical feasibility analysis annual saving was calculated.

## REFERENCES

- [1] M.C. Percival, P.S. Leung, P.K. Datta, "The Development of a Vertical Turbine for Domestic Electricity Generation," Univ. of Northumbria.
- [2] April 2000 Southwest Windpower, [Online]. Available: <http://www.windenergy.com>
- [3] Marier D, "Dynamometer Proportional Load Control," M. Eng. thesis, Kakatiya University, India May, 2001.
- [4] Aye K.S, Wanna S, 2002, *New features of the MIGAL solver*, Proc. Of the Phoenix Users Int.Conf., Moscow, Sept. 2002
- [5] Hilkat S, Oguz S, Vosper 2005, *Neutral Turbulent flow over forested hills*. Quart. J. Roy. Meteorol. Soc. 131:1841–1862
- [6] Retrieved Feb. 11, 2010 from the World Wide Web: [http://en.wikipedia.org/wiki/Small\\_scale\\_wind\\_power](http://en.wikipedia.org/wiki/Small_scale_wind_power)
- [7] Retrieved Feb. 16, 2010 from the World Wide Web: <http://en.wikipedia.org/wiki/formation/>
- [8] The Combined Power Plant: the first stage in providing 100% power from renewable energy". SolarServer. January 2008.

[http://www.solarserver.de/solarmagazin/anlagejanuar2008\\_e.html](http://www.solarserver.de/solarmagazin/anlagejanuar2008_e.html). Retrieved 2008-10-10.

[9] Green Energy Ohio. 2008-01-10.  
[http://www.development.cuyahogacounty.us/pdf\\_development/en-US/ExeSum\\_WindResrc\\_CleveWtrCribMntr\\_Reprt.pdf](http://www.development.cuyahogacounty.us/pdf_development/en-US/ExeSum_WindResrc_CleveWtrCribMntr_Reprt.pdf). Retrieved 2008-11-27.

[10] Common Affordable and Renewable Electricity Supply for Europe" Claverton Energy Conference, Bath, October 24th 2008

[11] Net Generation by Energy Source: Total (All Sectors)". Energy Information Administration (EIA), Dept. of Energy (DOE). September 11, 2009.  
[http://www.marlec.com/cneaf/electricity/epm/table1\\_1.html](http://www.marlec.com/cneaf/electricity/epm/table1_1.html). Retrieved 2009-09-22.

[12] Massachusetts — 50 m Wind Power" (JPEG). U.S. National Renewable Energy Laboratory. 6 February 2007.  
[http://www.cere.energy.gov/windandhydro/windpoweringamerica/images/windmaps/ma\\_50m\\_800.jpg](http://www.cere.energy.gov/windandhydro/windpoweringamerica/images/windmaps/ma_50m_800.jpg). Retrieved 2008-01-15.

[13] Blackwell BB, Sheldahl R, Feltz LV. Wind Tunnel Performance Data for Two and Three Bucket Savonius Rotor. *Journal of Energy* 1978; **2**:160-164.

[14] Watts, Jonathan (2008-07-25). "Energy in China: 'We call it the Three Gorges of the sky. The dam there taps water, we tap wind'". *The Guardian*.

<http://www.guardian.co.uk/environment/2008/jul/25/renewableenergy.alternativeenergy>. Retrieved 2008-10-07

[15] Neil, C. (2009). Darrieus Wind Turbines. Retrieved Jan 14, 2010 from the World Wide Web: <http://www.reuk.co.uk/Darrieus-Wind-Turbines.htm>

[16] Musgrove wind turbine. Retrieved November 29, 2009 from the World Wide Web: [www.memagazine.org/.../apptowind/apptowind.html](http://www.memagazine.org/.../apptowind/apptowind.html).

[17] Savonius wind turbine. Retrieved January 15, 2010 from the World Wide Web: [www.britannica.com/.../1384/A-Savonius-rotor](http://www.britannica.com/.../1384/A-Savonius-rotor)

[18] Wwindea (2009). World wind energy report 2008. Retrieved Jan 10, 2010 from the World Wide Web: [http://www.wwindea.org/home/images/stories/worldwindenergyreport2008\\_s.pdf](http://www.wwindea.org/home/images/stories/worldwindenergyreport2008_s.pdf)

## **APPENDICES**

## Appendix A

### Theoretical Aspects of wind energy

#### A1: Power in the wind

One of the most important factors of designing a wind system is to know how much power is available in the wind. As we know air is a mixture of gases and it contains a lot of substances. A container full of water is same as a container full of air, but the container containing air is lighter; because the density of air is smaller than water. When the wind strikes to an object it applies some force to it and cause the object to move [12]. From this action kinetic energy of the wind can be proved.

$$\text{Kinetic Energy} = \frac{1}{2} m S^2 \quad (\text{A-1})$$

Where  $m$  is air's mass ( $m$ ) and  $S$  is wind speed ( $m/s$ ). The air's mass can be determined from the product of air's density and its volume. The volume can be found by swept area  $A$  times wind speed  $S$  during time period  $t$ .

$$m = SAtd \quad (\text{A-2})$$

Where  $d$  is density ( $Kg/m^3$ ) of the air [13].

$$\text{Wind energy} = \frac{1}{2} (dAst) S^2 = \frac{1}{2} dAtS^3 \quad (\text{A-3})$$

Power is the rate at which energy is available.

$$P = \frac{1}{2} \rho A S^3 \quad (\text{A-4})$$

Factors which affect the wind power are: air density, swept area of the turbine, and wind speed

Change in swept area has a direct effect on the power output of the wind turbine. If the area is increased by two, the power output will be increased by two; because the turbine will be able to capture more wind [14].

$$A = \pi R^2$$

Doubling the rotor diameter increases the swept area by four.

$$A/\pi = R^2 = (1/2)^2 = \frac{2 \times 2}{1 \times 1} = 4$$

Same as air density, swept area of the wind turbine also affect the output power of the wind turbine. The swept area is shown with A and it is square of radius multiply with  $\pi$ . The radius of the wind turbine is approximately equal to length of one blade.

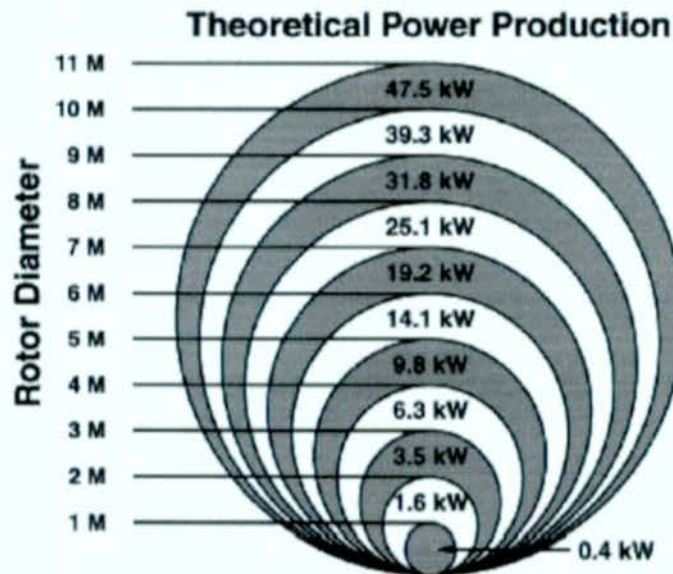

Figure A-1: Theoretical power production in different rotor diameter [15]

$$A = \pi R^2$$

The most important factor affecting power output of a wind turbine is wind speed, because power in the wind is cubic function of wind speed. Consider two sites where there is only 20% difference in wind speed. At one site wind speed is 5 (m/s) and at the other site wind speed is 6 (m/s). How much does it affect the power produced?

$$P_2/P_1 = \left( S_2/S_1 \right)^3 = \left( 6/5 \right)^3 = 1.73 \text{ therefore } P_2 = 1.73P_1 \quad (\text{A-5}) [16]$$

Only 20% increase in wind speed affect the power produced by 73%.

Now assume 50% increase in wind speed.

$$P_2/P_1 = \left( S_2/S_1 \right)^3 = \left( 10/5 \right)^3 = 8 \text{ therefore } P_2 = 8P_1$$

When wind speed is increased by 2, power will be increased by eight times.

At this point it is important to know which speed should be used. Average wind speed alone will not give the correct result, if the average wind speed is used directly to the power equation, there would be more than 50% error. If somebody asks why the average can't be used directly, the answer is time variance of the speed. The wind speed varies from time to time. Average wind speed contains above and below numbers of average. To estimate the power, power density should be calculated firstly. Let's assume average annual speed of 6 m/s.

$$P/A = \frac{1}{2} \rho v^3 \quad (A-6)$$

Power density is a relation which wind experts use it because it is a good parameter to see how much electricity can be obtained during a period, typically one year. Power density is given in units of watts per square meter. So take the temperature of air 15 C° at sea level and substitute air density.

$$P/A = 0.6125 \rho v^3, \text{ where } v \text{ is in meters per second [17]}$$

$$P/A = 0.6125 (6)^3 = 132.3 \text{ W/m}^2$$

So how will be the rate of power if half of the time there is 3m/s and half of time 9m/s! The average speed still will be the same! Let's check how power density will change when these two speeds are used.

$$\text{At 3 m/s, } P/A = 0.6125 (3)^3 = 16.5 \text{ W/m}^2$$

$$\text{At } 9 \text{ m/s, } P/A = 0.6125 (9)^3 = 446.5 \text{ W/m}^2$$

$$\text{Average } P/A = \frac{16.5 \frac{\text{W}}{\text{m}^2} + 446.5 \frac{\text{W}}{\text{m}^2}}{2} = 231.5 \text{ W/m}^2$$

As it is seen power density  $P/A$  is  $231.5 \text{ W/m}^2$ , when we compare with  $132.3 \text{ W/m}^2$  a big difference can be recognized. Most of the power will be provided from amount of wind above the average. If the graph of wind speed versus time is plotted it can be noticed that there is sometimes no wind, windy and extremely windy periods. The distribution of wind speed vary from place to place, but in general they follow a bell-shaped curve like Rayleigh distributions at a site where has different average wind speed. The power density can be obtained from distribution of Rayleigh for any average wind speed.

## Appendix B

### Experimental Data with the Aim of Graph

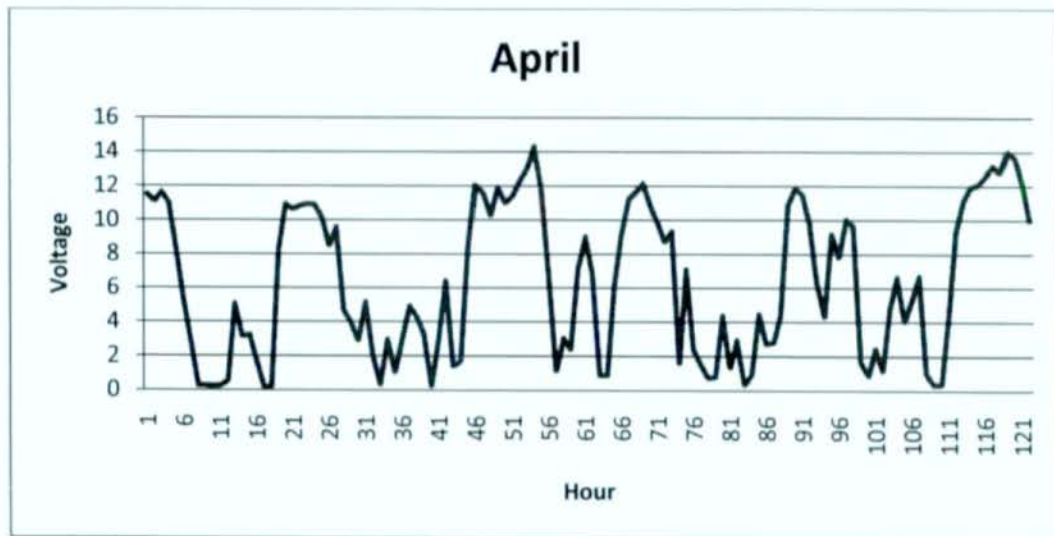

Figure A-1: Voltage versus Hours graph in April

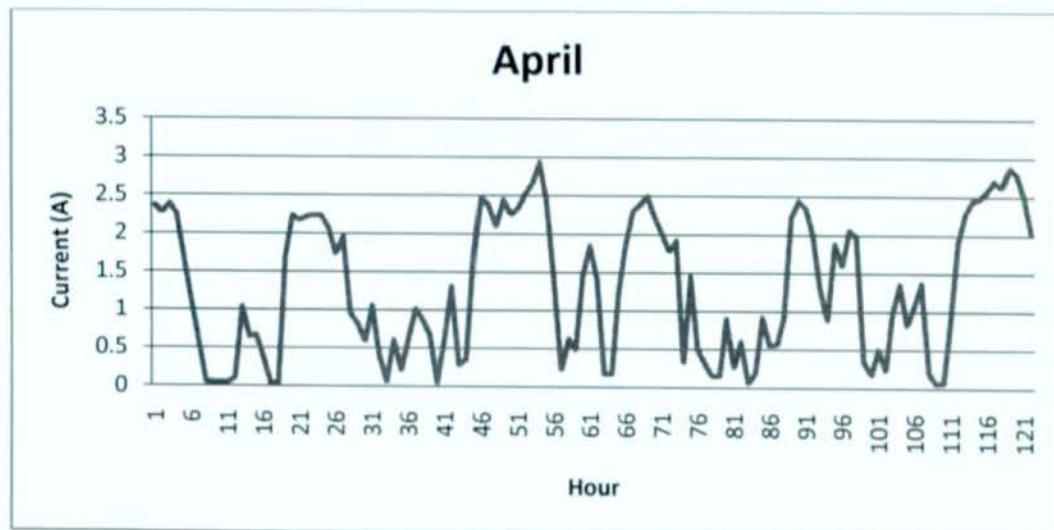

Figure A-2: Current versus Hours graph in April

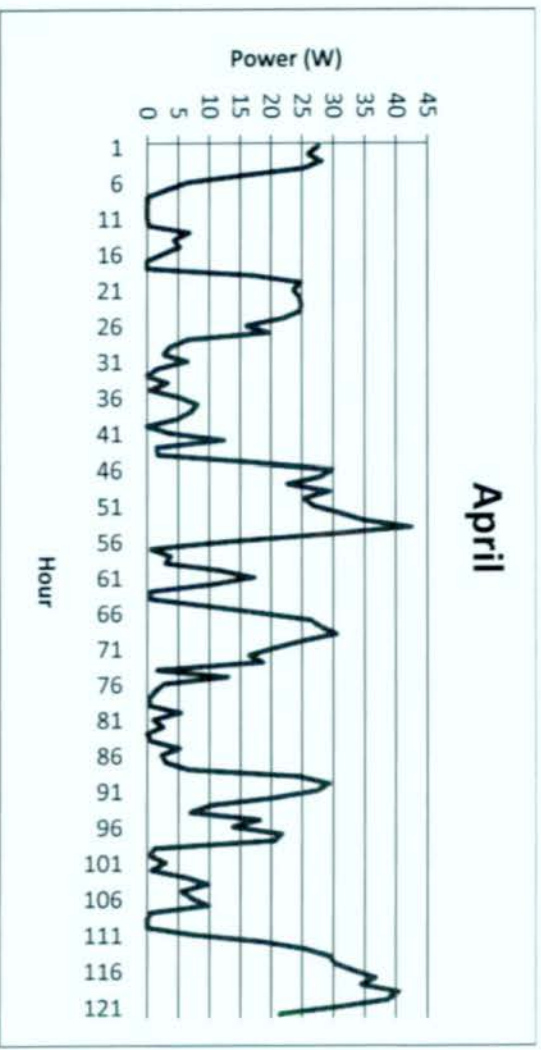

Figure A-3: Power versus Hours graph in April

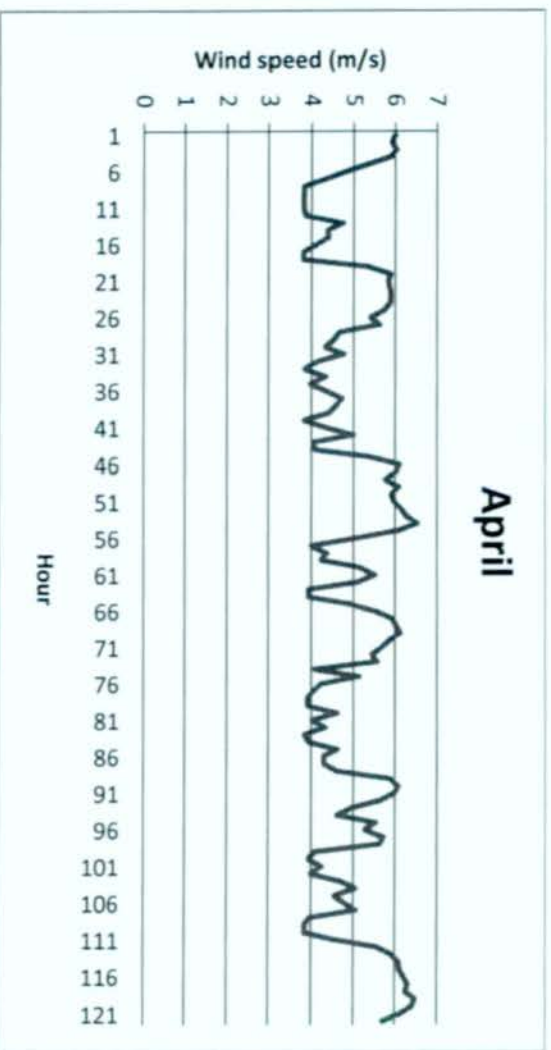

Figure A-4: Wind speed versus Hours graph in April

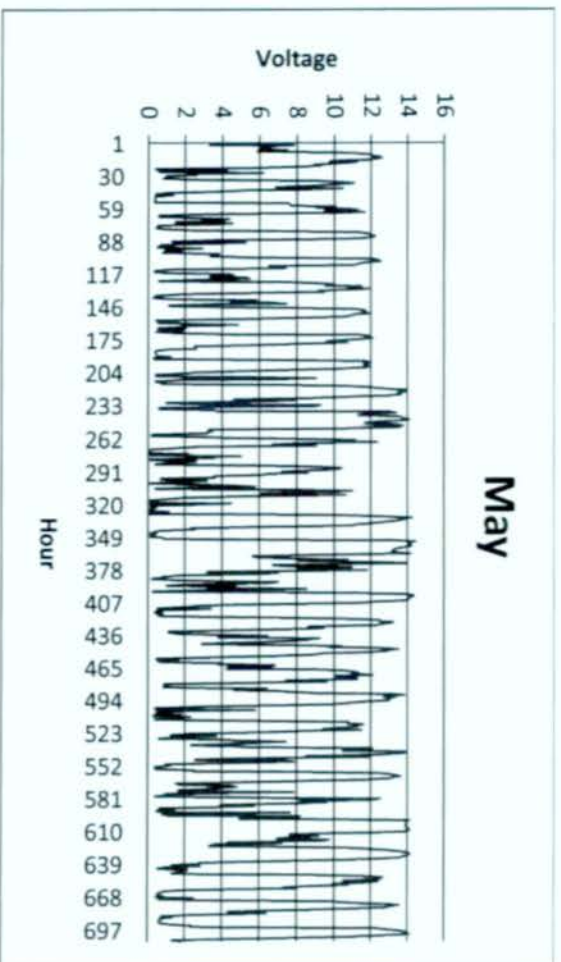

Figure A-5: Voltage versus Hours graph in May

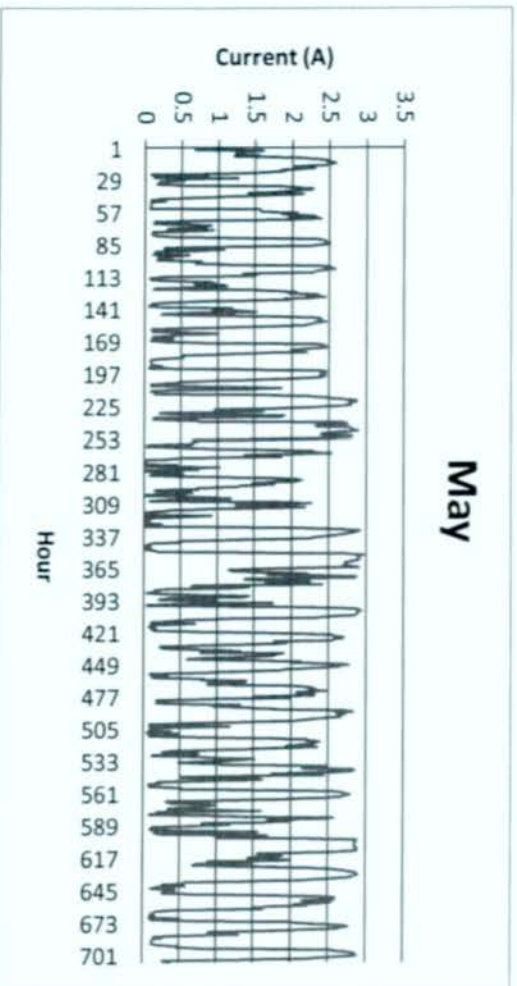

Figure A-6: Current versus Hours graph in May

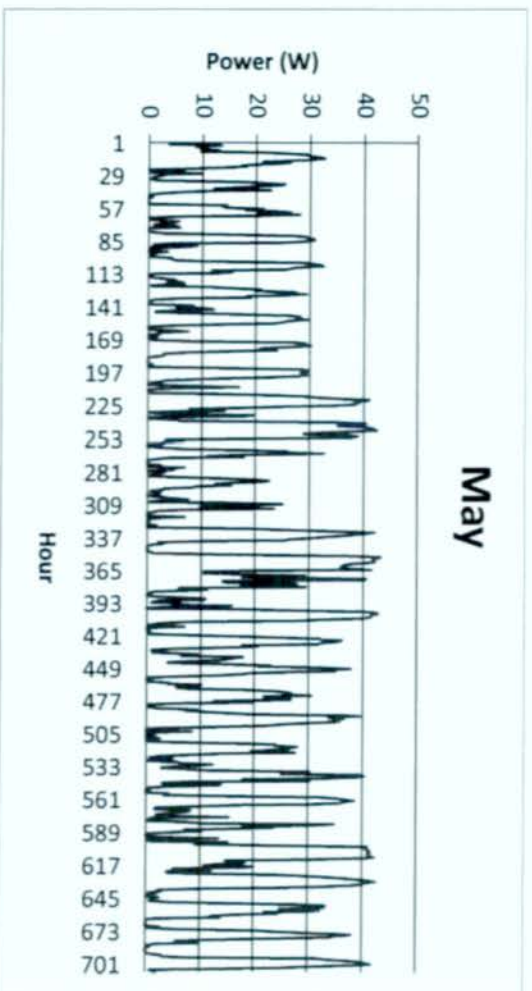

Figure A-7: Power versus Hours graph in May

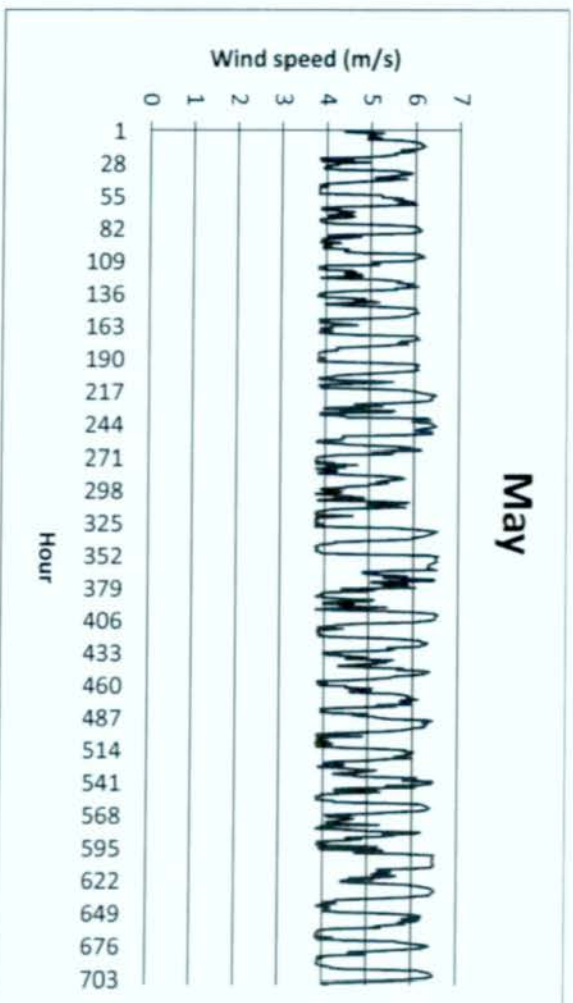

Figure A-8: Wind speed versus Hours graph in May

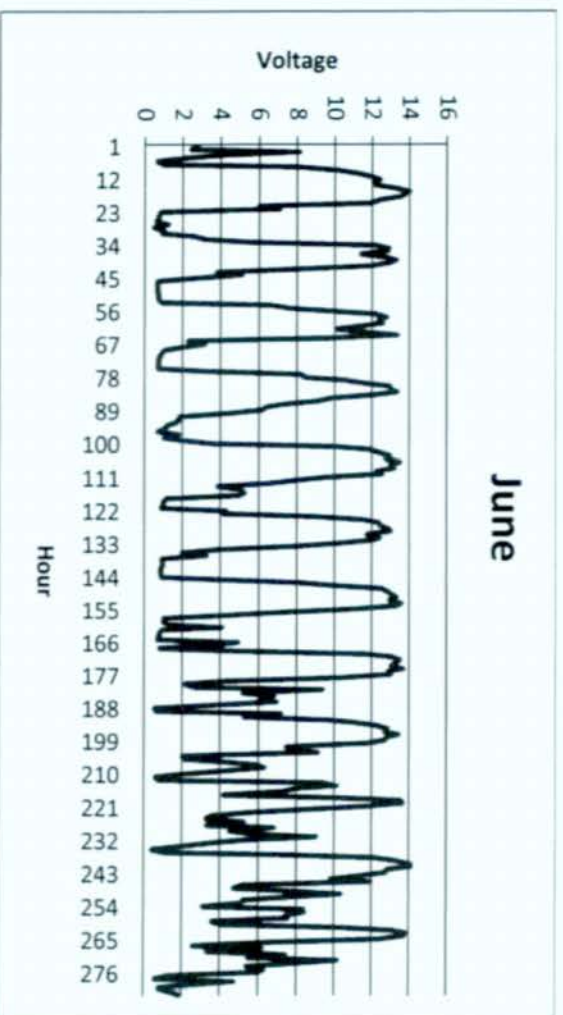

Figure A-9: Voltage versus Hours graph in June

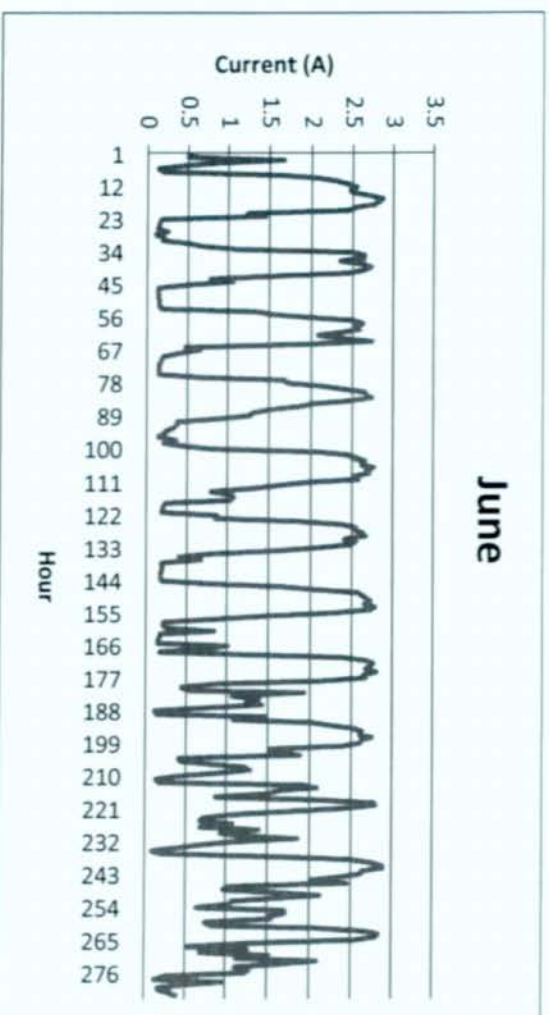

Figure A-10: Current versus Hours graph in June

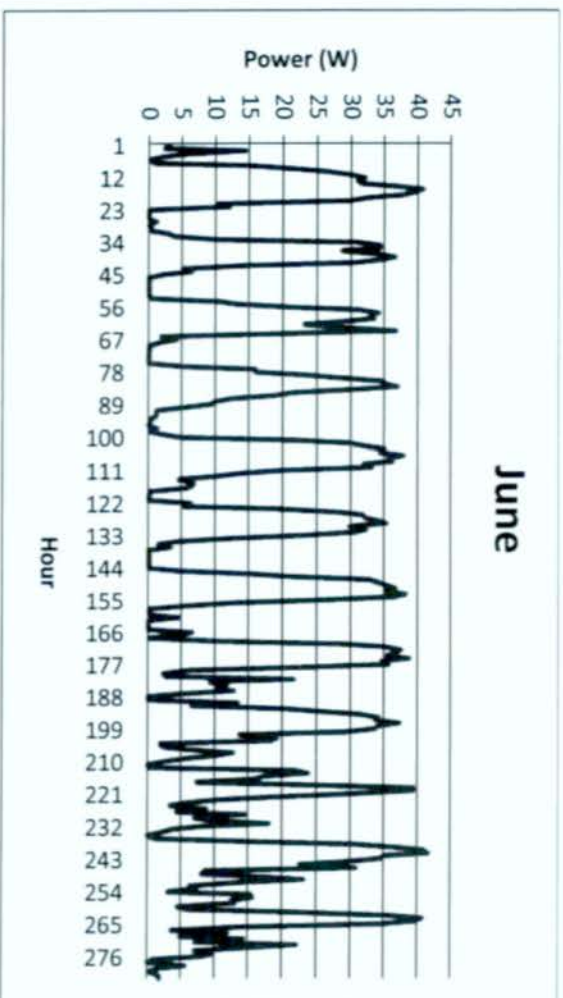

Figure A-11: Power versus Hours graph in June

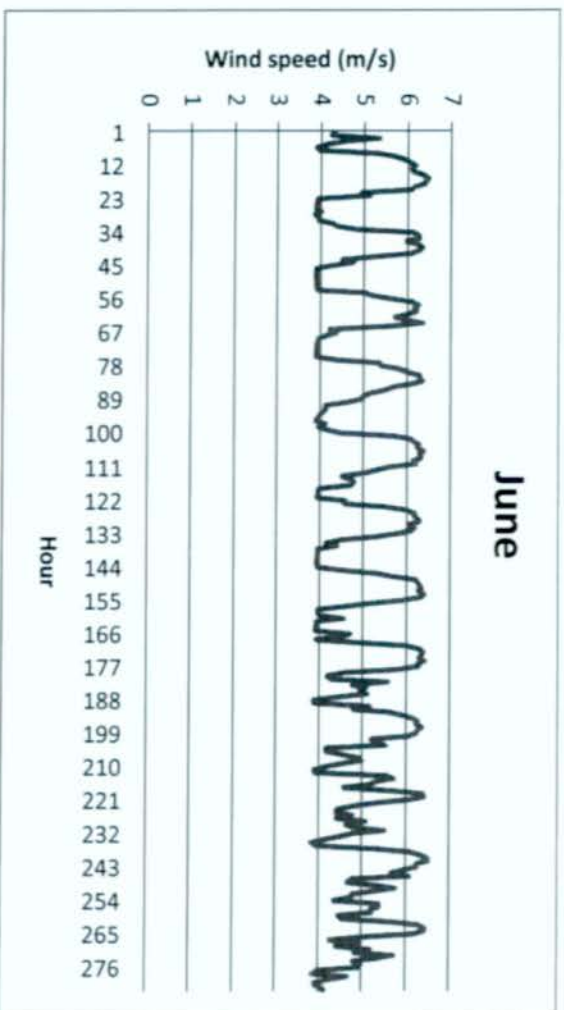

Figure A-12: Wind speed versus Hours graph in June

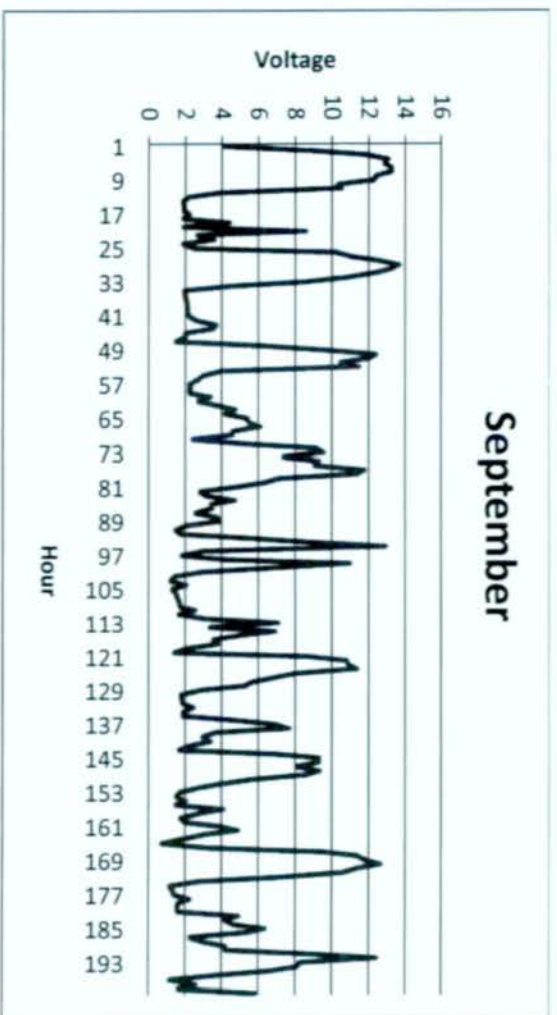

Figure A-13: Voltage versus Hours graph in September

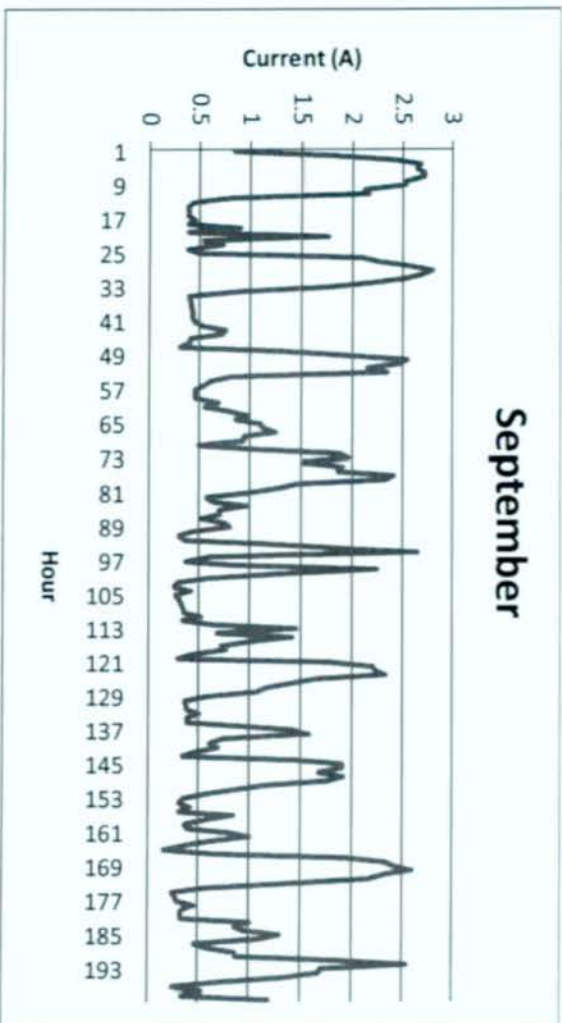

Figure A-14: Current versus Hours graph in September

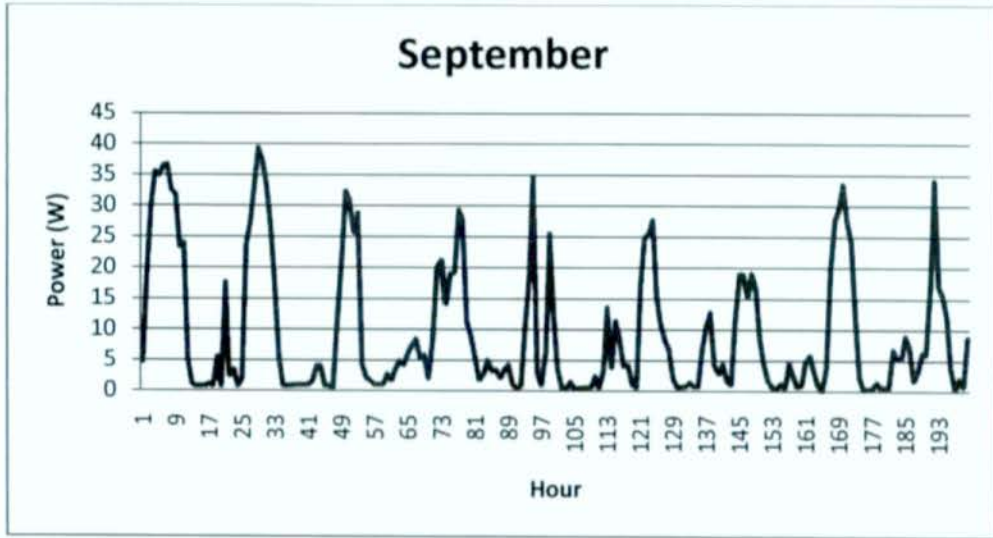

Figure A-15: Power versus Hours graph in September

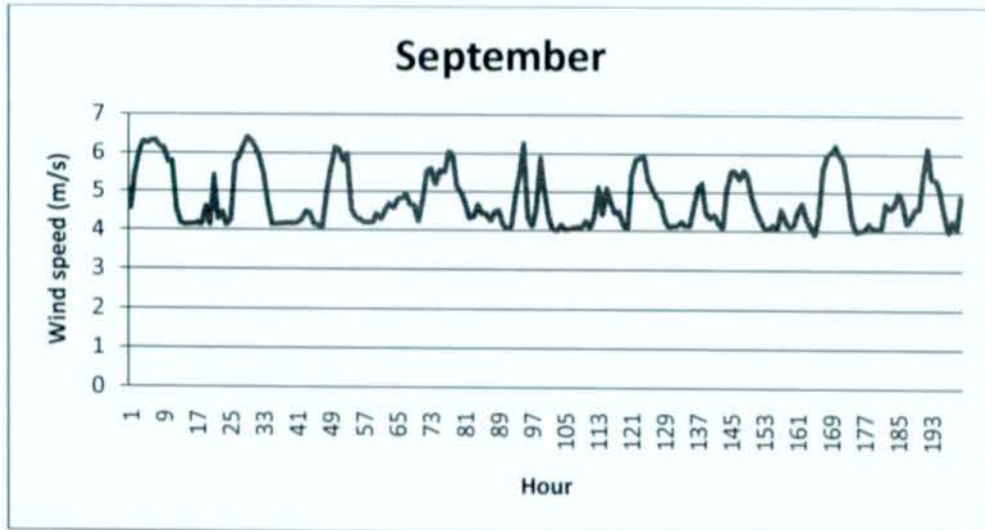

Figure A-16: Wind speed versus Hours graph in September

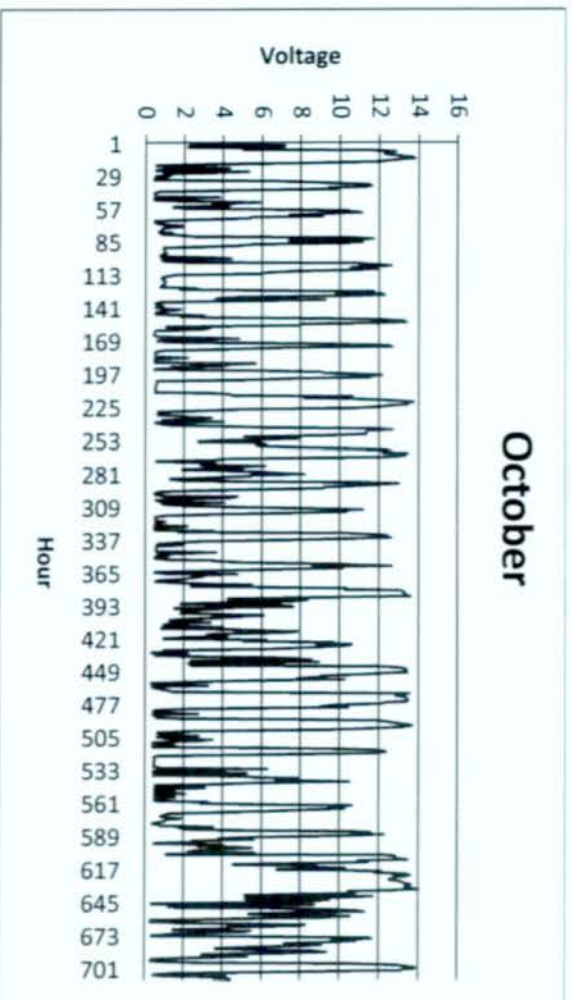

Figure A-17: Voltage versus Hours graph in October

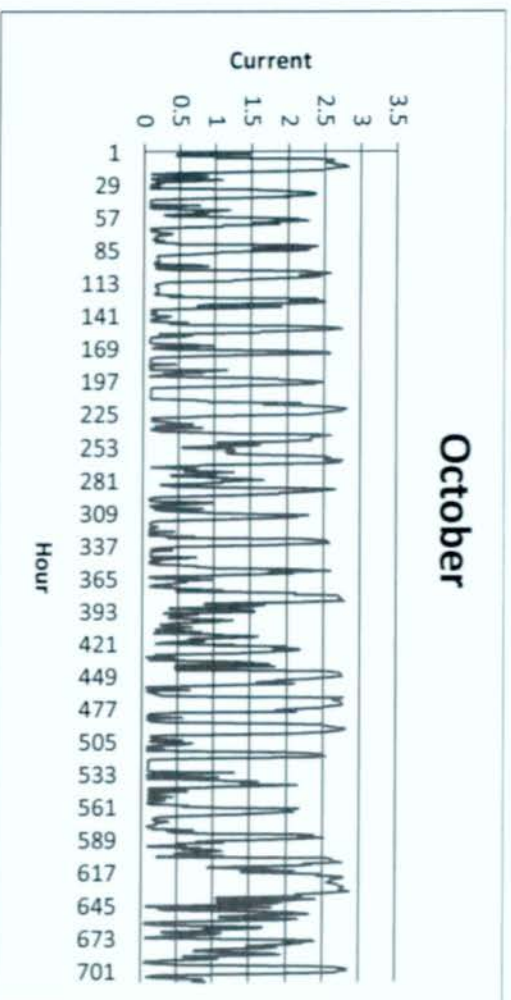

Figure A-18: Current versus Hours graph in October

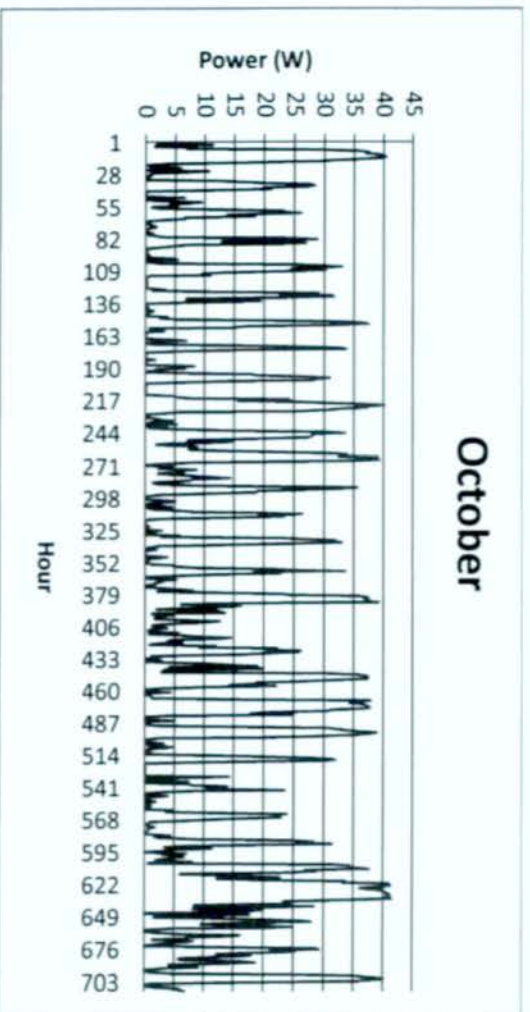

Figure A-19: Power versus Hours graph in October

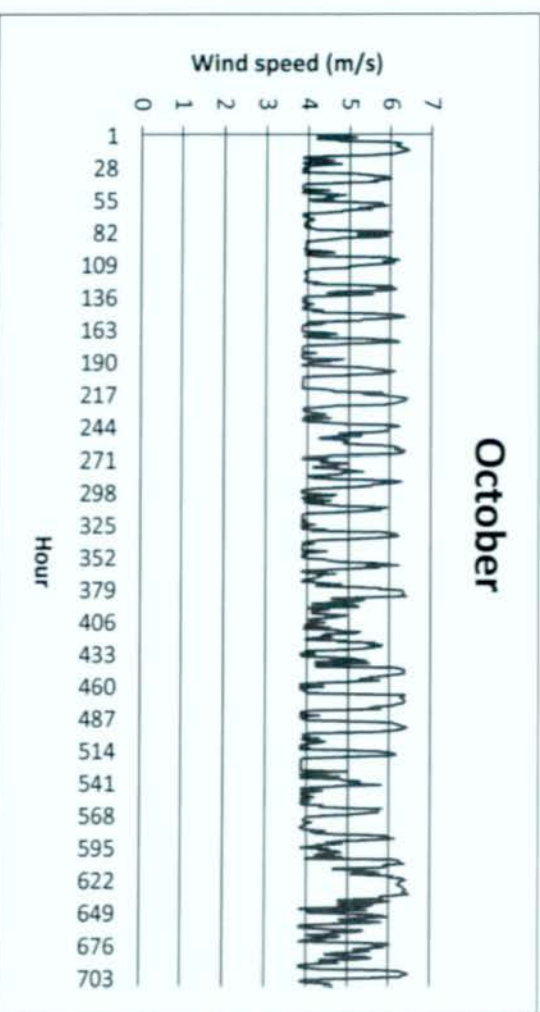

Figure A-20: Wind speed versus Hours graph in October

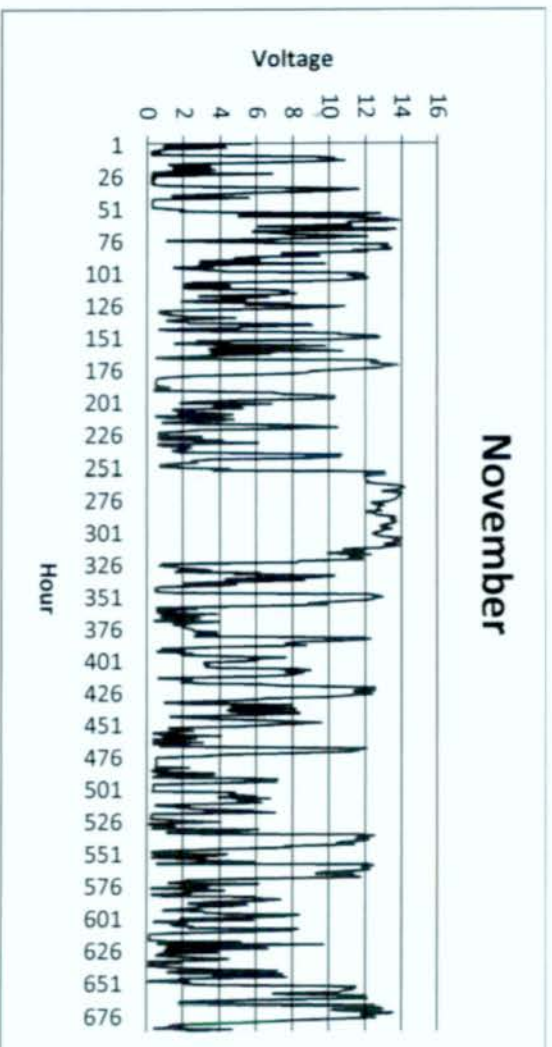

Figure A-21: Voltage versus Hours graph in November

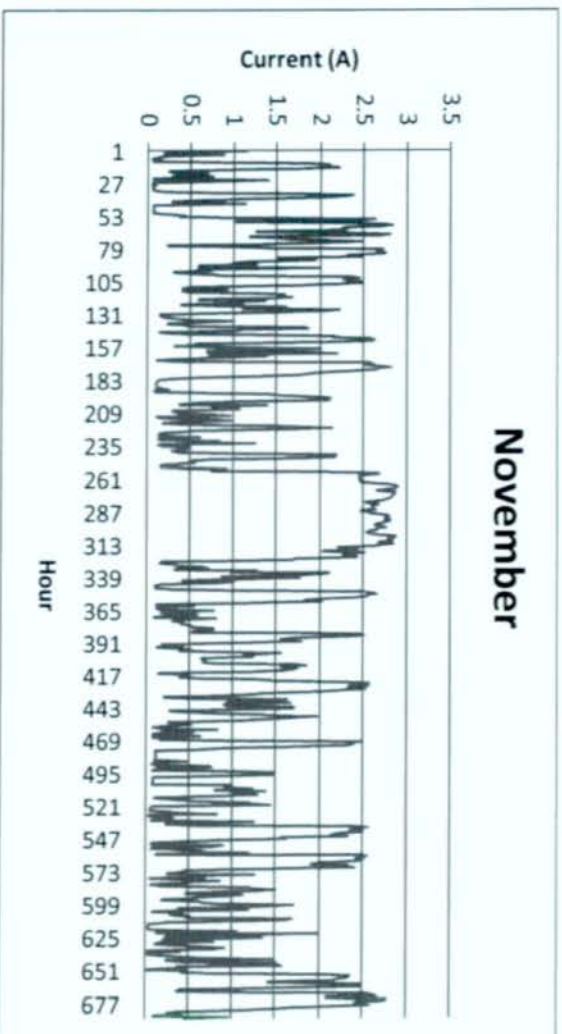

Figure A-22: Current versus Hours graph in November

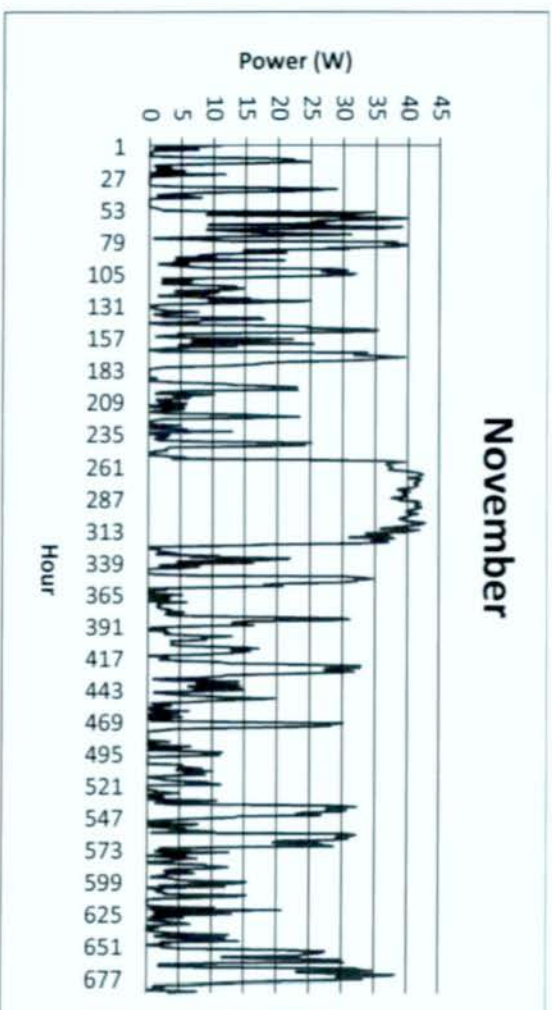

Figure A-23: Power versus Hours graph in November

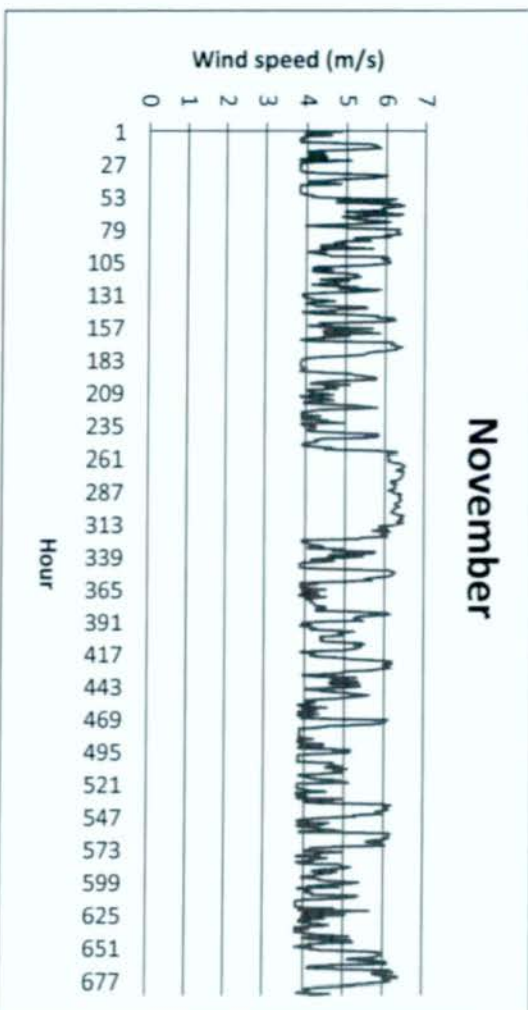

Figure A-24: Wind speed versus Hours graph in November

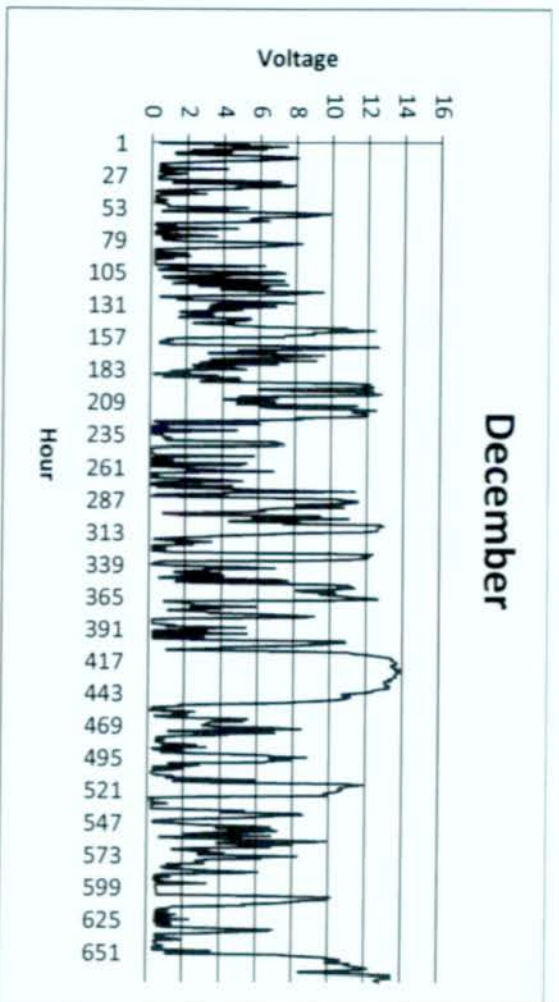

Figure A-25: Voltage versus Hours graph in December

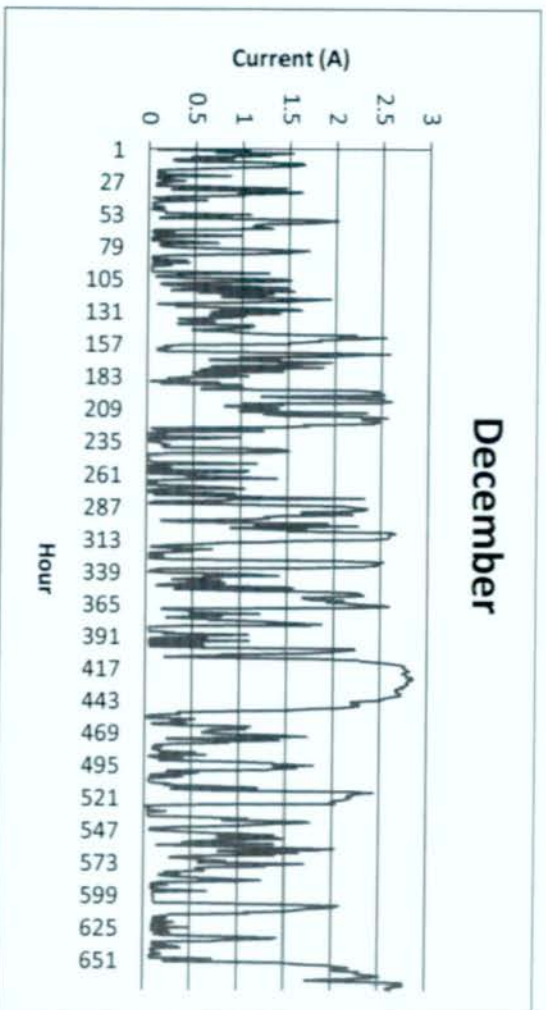

Figure A-26: Current versus Hours graph in December

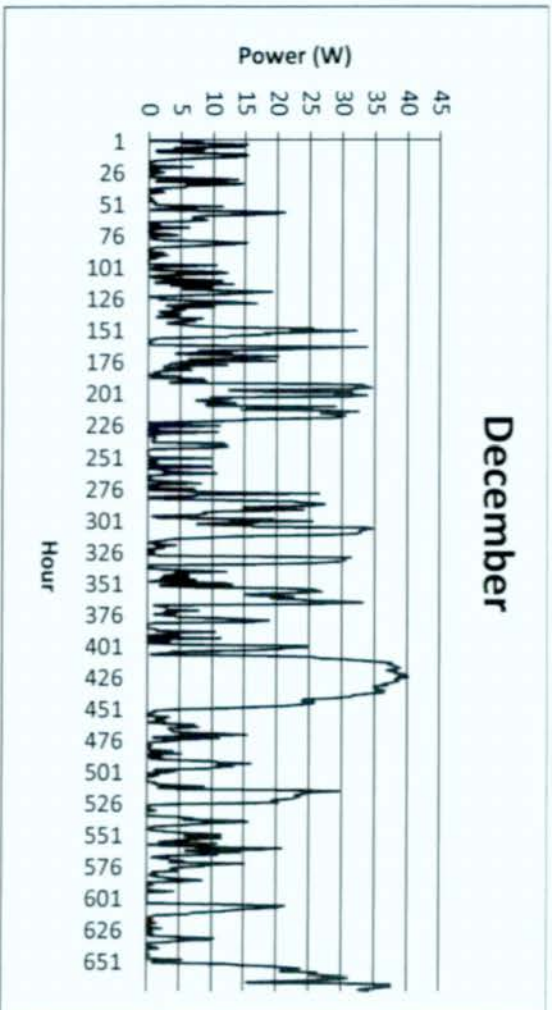

Figure A-27: Power versus Hours graph in December

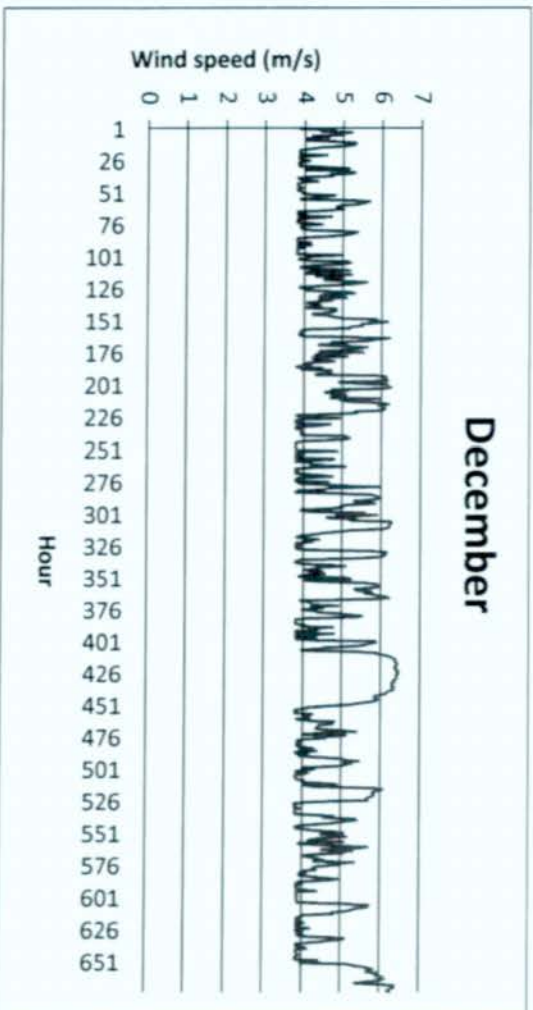

Figure A-28: Wind speed versus Hours graph in December

## Appendix C

### Europe and Western Asia Wind Classifications by US

Department of Energy

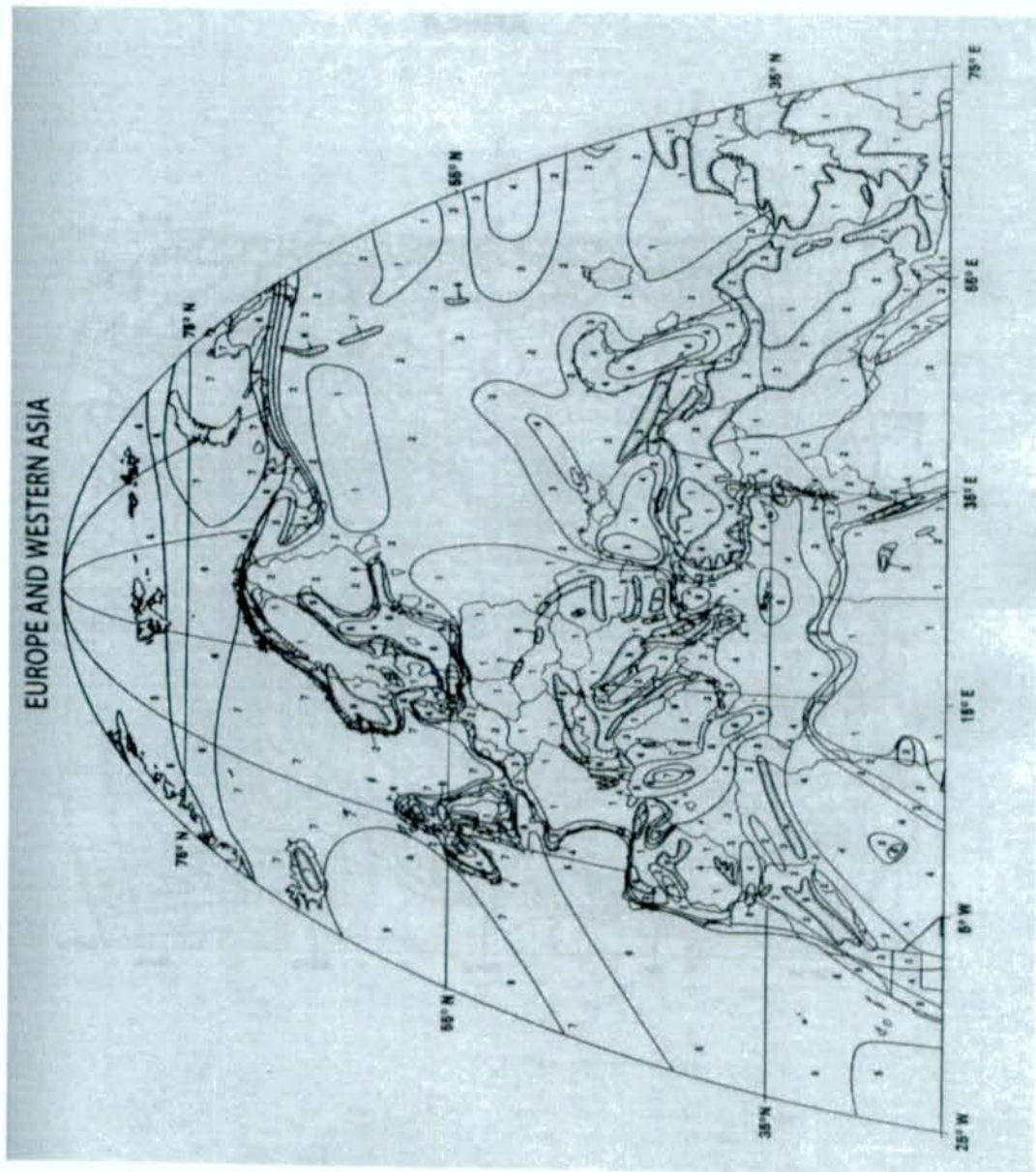



Figure A-1: Europe and western Asia wind classifications [18]

Figure A-2: Classes of wind power density [18]

WIND POWER CLASS	10m (33 ft)			50m (164 ft)		
	WIND POWER	SPEED		WIND POWER	SPEED	
	W/m <sup>2</sup>	m/s	mph	W/m <sup>2</sup>	m/s	mph
1	0	0	0	0	0	0
2	100	4.4	9.8	200	5.6	12.5
3	150	5.1	11.5	300	6.4	14.3
4	200	5.6	12.5	400	7.0	15.7
5	250	6.0	13.4	500	7.5	16.8
6	300	6.4	14.3	600	8.0	17.9
7	400	7.0	15.7	800	8.8	19.7
	1000	9.4	21.1	2000	11.9	26.6

 RIDGE CREST ESTIMATES (LOCAL RELIEF = 1000 FT)

## Appendix D

### Basic Program Codes for Monitoring Software

```
$regfile "m8def.dat"  
$crystal = 8000000  
$baud = 9600  
Config Lcdpin = Pin , Db4 = Portb.4 , Db5 = Portb.5 , Db6 = Portb.6 , Db7 = Portb.7  
, E = Portb.0 , Rs = Portb.1  
Config Lcd = 16 * 2  
'Config Single = Scientific , Digits = 5  
Cls  
Config Adc = Single , Prescaler = Auto  
Dim W As Word , Channel As Byte , V As Single , I As Single , P As Single , Ws As  
Single , Wf As Single  
Channel = 0  
Start Adc  
Home  
Cls  
Lcd "Voltage(v):"  
Lowerline  
Lcd "Current(mA):"  
Cursor Off
```

```
Do
W = Getadc(channel)
V = W / 40
Locate 1 , 13
Lcd V
Print V
I = W / 195
Locate 2 , 14
Lcd I
Print I
P = V * I
Print P
Wf = I + 3.989
Ws = Wf / 1.0582
Print Ws
Waitms 2000
Loop
End
```

## **Appendix E**

### **Life Cycle Analysis**

## Life Cycle Cost Analysis Input

Input in BLUE cells only.

### INSTRUCTIONS

**TABLE 1**

Life Cycle Investment Schedule, from Steps 1, 2, and 3

Year	New	Old	Net Amount
0	\$700		\$700
1			\$0
2			\$0
3			\$0
4			\$0
5			\$0
6			\$0
7			\$0
8			\$0
9			\$0
10			\$0
11			\$0
12			\$0
13			\$0
14			\$0
15			\$0
16			\$0
17			\$0
18			\$0
19			\$0

**Table 1: Life Cycle Investment Schedule**

- In Year 0, New: Enter sum of new initial investments of ECMs.
- In Year 0, Old: Enter sum of replacement costs required in year 0 for old technologies in all ECMs.
- In Year 1-19: Enter schedule of future costs (replacement costs not counted in annual operation & maintenance) for new and old technologies in all ECMs.

The net amount for each year is the difference between old costs and new costs for each year. These are automatically calculated by the spreadsheet.



Net Cash Flows  
(for IRR calculation)

(\$700)	\$35	\$35	\$35	\$35	\$35	\$35	\$35	\$35	\$35	\$35	\$35
---------	------	------	------	------	------	------	------	------	------	------	------

## Life Cycle Cost Analysis Output

### TABLE 5: Results

Net Present Value (NPV)

OUTPUTS
<b>-\$309</b> (from Step 9)

Savings-to-Investment Ratio

<b>0.5</b> (from Step 10)
---------------------------

Internal Rate of Return (IRR)

<b>0%</b> (from Step 10)
--------------------------

Simple Payback (years)

<b>20.0</b>
-------------

### Formulas:

Life Cycle Net Savings

$$= \sum PV \text{ Annual Savings} - \sum PV \text{ Life Cycle Investments}$$

Savings-to-Investment Ratio

$$= \sum PV \text{ Annual Savings} / \sum PV \text{ Life Cycle Investments}$$

Internal rate of return

$$= \text{Discount rate, where } SR = 1.0, \text{ or } NPV = 0$$

Simple payback

$$= \text{Initial investment} / \text{annual savings}$$