

**TRANSMITTING FSK SIGNALS BASED ON  
SOFTWARE DEFINED RADIO USING HACKRF  
ONE**



**2017  
M. Sc. Thesis  
Electrical and Electronics Engineering**

**Abdulgader Elamin Elsaghier**

**TRANSMITTING FSK SIGNALS BASED ON SOFTWARE DEFINED  
RADIO USING HACKRF ONE**

**A THESIS SUBMITTED TO  
THE GRADUATE SCHOOL OF NATURAL AND APPLIED SCIENCES  
KARABUK UNIVERSITY**

**BY**

**Abdulgader Elamin ELSAGHIER**

**IN PARTIAL FULFILLMENT OF THE REQUIREMENTS FOR  
THE DEGREE OF MASTER OF SCIENCE  
INDEPARTMENT OF  
ELECTRICAL-ELECTRONICS ENGINEERING**

**September 2017**

I certify that in my opinion the thesis submitted Abdulgader Elamin ELSAGIER titled “TRANSMITTING FSK SIGNALS BASED ON SOFTWARE DEFINED RADIO USING HACKRF ONE” is fully adequate in scope and in quality as a thesis for the degree of Master of Science.

Assoc. Prof. Dr. Necmi Serkan TEZEL  
Thesis Advisor, Department of Electrical-Electronics Engineering



This thesis is accepted by the examining committee with a unanimous vote in the Department of Electrical-Electronics Engineering as a master thesis. September 13, 2017

Examining Committee Members (Institutions)

Signature

Chairman : Assoc. Prof. Dr. Ziyodulla YUSUPOV (KBÜ)

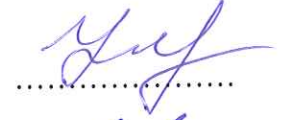

Member : Assoc. Prof. Dr. Necmi Serkan TEZEL (KBÜ)



Member : Assist. Prof. Dr. Murat LÜY (KKÜ)

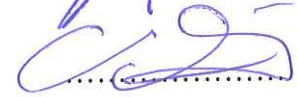

..... / ..... / 2017

The degree of Master of Science by the thesis submitted is approved by the Administrative Board of the Graduate School of Natural and Applied Sciences, Karabuk University.

Prof. Dr. Filiz ERSÖZ



Head of Graduate School of Natural and Applied Sciences



*“I declare that all the information within this thesis has been gathered and presented in accordance with academic regulations and ethical principles and I have according to the requirements of these regulations and principles cited all those which do not originate in this work as well.”*

Abdulgader Elamin ELSAGHIER

## **ABSTRACT**

**M. Sc. Thesis**

### **TRANSMITTING FSK SIGNALS BASED ON SOFTWARE DEFINED RADIO USING HACKRF ONE**

**Abdulgader Elamin ELSAGHIER**

**Karabük University**

**Graduate School of Natural and Applied Sciences**

**Department of Electrical and Electronics Engineering**

**Thesis Advisor:**

**Assoc. Prof. Dr. Necmi Serkan TEZEL**

**September 2017, 44 pages**

Practically, a communication transmitter is a part of a communication network, which accepts input signals, arranges the information transmission process on a certain transmission link and increases the output power to get a successful transmission. It consists of an oscillator that produces a carrier frequency and a buffer amplifier that offers a high impedance load in order to reduce drifts and modulated using amplified intelligence signal. The most common used digital modulation technique in wireless communications is the Frequency Shift Keying (FSK), which is a frequency modulation that uses modulating wave shifts to choose one of two recognized frequencies to the corresponding output. Therefore, this project aims to implement Software Defined Radio (SDR) using HACKRF One to transmit FSK signal and evaluate its performance. Various environment measurements are carried out in this project to assess the system performance with

using an interface to measure the signal reception quality. Results revealed that the transmitter is able to keep its position constant for all experiments according to the included points in the experimental environment, which includes two rooms with a door connecting them. Furthermore, the lowest needed power was for open door case among both rooms.

**Key Words** : FSK, hackrf one, transmitter, modem, gnu radio.

**Science Code** : 905.1.067



## **ÖZET**

**Yüksek Lisans Tezi**

### **YAZILIM TABANLI RADYO İLE HACKRF ONE KULLANARAK FSK SİNYALLERİNİN İLETİMİ**

**Abdulgader Elamin ELSAGHIER**

**Karabük Üniversitesi**

**Fen Bilimleri Enstitüsü**

**Elektrik-Elektronik Mühendisliği Anabilim Dalı**

**Tez Danışmanı:**

**Doç. Dr. Necmi Serkan TEZEL**

**September 2017, 44 sayfa**

Pratik olarak, bir iletişim vericisi, giriş sinyallerini kabul eden, belli bir iletim hattı üzerinde bilgi aktarım işlemini düzenler ve başarılı bir iletim elde etmek için çıkış gücünü arttıran bir iletişim ağının bir parçasıdır. Taşıyıcı frekansı üreten bir osilatör ve sürüklenmeleri azaltmak için yüksek empedans yükü sunan ve yükseltilmiş bilgi sinyali kullanılarak modüle edilen bir tampon amplifikatörden oluşur. Kablosuz iletişimde en yaygın olarak kullanılan dijital modülasyon tekniği, frekansı kaydırmalı anahtarlama (FSK). Bu, frekans modülasyonunda modüle edilen dalga kaymalarıyla tanınan iki frekanstan birini çıkış olarak seçer. Bu nedenle, bu çalışmada FSK sinyalini iletmek ve performansını değerlendirmek için HACKRF One' ı kullanarak Yazılım Tabanlı Radyo (SDR) uygulamayı amaçlamaktadır. Bu projede, sinyal alımı kalitesini ölçmek için bir ara yüz kullanarak sistem performansını değerlendirmek için çeşitli çevre ölçümleri yapılmıştır. Sonuçlar, verici sabit bir konumda tutularak ve deney ortamında yer alan ve bunları birbirine

bağlayan bir kapı bulunan iki oda içeren noktalara göre alınan işaret elde edilerek değerlendirildi. Ayrıca, belirli bir alış gücü seviyesi için gerekli olan en düşük güç, her iki oda arasında kapının açık olduğu durumda olduğu görüldü.

**Anahtar Kelimeler** : FSK, hackrf one, transmitter, modem, gnu radio.

**Bilim Kodu** : 905.1.067



## **ACKNOWLEDGMENT**

First of all, I would like to give thanks to my advisor, Assoc. Prof. Dr. Necmi Serkan TEZEL, for his great interest and assistance in preparation of this thesis.

I am highly grateful to the head and all teachers of the Electrical-Electronics Engineering Department, Karabük University who took the time to offer me guidance. I would also like to thank my great mother, my lovely family and friends, for their encouragement, support and unwavering love, which make my dream come true. I appreciate support and patience of my wife and family.

This work was supported by the Karabük University Scientific Research Project Unit under contract No. KBÜ-BAP-17-YL-033. We would like to thank the Karabük University Scientific Research Project Unit for their financial support.

## CONTENTS

	<b><u>Page</u></b>
APPROVAL.....	ii
ABSTRACT.....	iv
ÖZET.....	vi
ACKNOWLEDGMENT.....	viii
CONTENTS.....	ix
LIST OF FIGURES.....	xi
LIST OF TABLES.....	xii
SYMBOLS AND ABBREVIATIONS INDEX.....	xiii
CHAPTER 1.....	1
INTRODUCTION.....	1
1.1. PROBLEM STATEMENT.....	4
1.2. OBJECTIVE OF STUDY.....	4
1.3. CONTRIBUTION.....	4
1.4. RESEARCH OUTLINE.....	4
CHAPTER 2.....	6
LITERATURE REVIEW.....	6
2.1. THE CONCEPT OF SOFTWARE DEFINED-RADIO.....	7
2.2. FREQUENCY SHIFT KEYING (FSK).....	10
2.2.1. Binary Frequency Shift Keying (BFSK).....	11
2.2.2. M-ary Frequency Shift Keying (MFSK).....	15
2.2.3. Gaussian Frequency Shift Keying (GFSK).....	15
2.3. SOFTWARE DEFINED RADIO HARDWARE PLATFORM.....	18
2.3.1. Universal Software Radio Peripheral.....	20
2.3.2. HackRF One.....	21
2.3.3. RTL_SDR.....	22
2.4. OPEN SOURCE SOFTWARE PLATFORM.....	22

	<u>Page</u>
2.4.1. GNU Radio .....	23
2.4.2. GNU Radio Features.....	25
2.4.3. C++ Programming Language .....	26
2.4.4. Python Programming Language .....	27
2.4.5. SWIG Software Development Tool.....	27
 CHAPTER 3 .....	 29
DESIGN AND IMPLEMENTATION.....	29
3.1. DESIGN CONSIDERATION .....	29
3.2. SCOPE OF THE STUDY .....	29
3.3. INSTRUMENT .....	30
3.3.1. HackRF One .....	30
3.3.2. GNU Radio Companion .....	31
3.4. IMPLEMENTATION .....	31
3.4.1. Design Diagram .....	32
3.4.2. Requirement.....	33
3.4.3. Software Block Diagram .....	33
 CHAPTER 4 .....	 36
RESULT AND DISCUSSION .....	36
 CHAPTER 5 .....	 40
CONCLUSION AND RECOMMENDATION.....	40
5.1. CONCLUSION .....	40
5.2. RECOMMENDATIONS .....	40
REFERENCES.....	41
 RESUME .....	 44

## LIST OF FIGURES

	<u>Page</u>
Figure 2.1. Transmitter and receiver of ideal software defined radio.....	8
Figure 2.2. Software-defined radio block diagram. ....	9
Figure 2.3. BFSK modulation. ....	12
Figure 2.4. Parameters of FSK.....	13
Figure 2.5. FSK signal waveform.. ....	14
Figure 2.6. Spectrum of FSK waveform. ....	14
Figure 2.7. M-ary FSK modulator. ....	15
Figure 2.8. General GFSK diagram. ....	16
Figure 2.9. SDR transmitter block diagram. ....	18
Figure 2.10. SDR receiver block diagram.....	19
Figure 2.11. GNU radio. ....	23
Figure 2.12. GNU configuration for osmocom source. ....	25
Figure 3.1. HackRFone architecture. ....	30
Figure 3.2. Proposed method diagram. ....	32
Figure 3.3. Transmitter subsystem.....	32
Figure 3.4. Receiver subsystem. ....	32
Figure 3.5. Hardware setup. ....	33
Figure 3.6. Transmitter block diagram.....	34
Figure 3.7. Receiver block diagram. ....	34
Figure 4.1. Received signal.....	36
Figure 4.2. Absence signal. ....	37
Figure 4.3. Signal power measurements. ....	37
Figure 4.4. Experiment environment. ....	38

## LIST OF TABLES

	<b><u>Page</u></b>
Table 2.1. Available SDR devices in the market. ....	19
Table 4.1. Experimental results.....	38



## SYMBOLS AND ABBREVIATIONS INDEX

### ABBREVIATIONS

ADC	:Analog Digital Converter
AM	: Analog Modulation
ASIC	: Application Specific Integrated Circuits
ASK	: Amplitude-Shift Keying
BER	: Bit Error Ratio
BFSK	: Binary Frequency Shift Keyings
CORBA	: Common Object Request Broker Architecture
CPFSK	: Continuous-Phase Frequency Shift Keying
DAC	: Digital Analog Converter
DDC	: Digital Down Converter
DM	: Delta Modulation
DPWM	: Digital Pulse Width Modulator
DSP	: Digital Signal Processors
DSP	: Digital Signal Processing
DUC	: Digital Up Converter
FIR	: Finite Impulse Response
FM	: Frequency Modulation
FPGA	: Field Programmable Gate Array
FSK	: Frequency Sift Keying
GFSK	: Gaussian Frequency Shift Keying
GPP	: General Purpose Processors
GRC	: GNU Radio Companion
IF	: Intermediate Frequency
ISM Bands	: Industrial, Scientific, and Medical radio band
MFSK	: M-ary Frequency Shift Keying
PPG	: Photo-Plethysmo-Gram

PRMS : Percentile Root Mean Square Error  
PSK : Phase-Shift Keying  
PWM : Pulse Width Modulator  
RF : Radio Frequency  
RX : Receiver  
SWIG : Simplified Wrapper and Interface Generator  
TX : Transmitter  
USRP : Universal Software Radio Peripheral  
VHDL : VHSIC Hardware Description Language





## CHAPTER 1

### INTRODUCTION

Software Defined Radio (SDR) has been a choice to develop a single hardware which is able to perform multiple waveforms. It introduced by Joseph Mitola in 1990s that known as an radio identifier which is possibly reprogrammed and reconfigured in form of a software. SDR's receiver ideally has components which are an antenna and an Analog Digital Converter (ADC) and the transmitter will consist of only a Digital Analog Converter (DAC) and an antenna transmission. Programmable processors would be handled some functions. Software-defined radio is a permeate technology which offers multiple services, standards, band, and reconfigurable radio systems, which based on a reprogrammable software. It is also defined as a radio that is considerably defined in software that the physical layer array can be changed through its software [1].

The other definition of SDR is "A communication system implementing most system blocks in software style and requires minimal hardware designs" [2]. This system is specifically designed to receive computation resources of multiple baseband. The SDR's transcendence is the minimum receiver area to perform various standards. The reprogrammable hardware resulted in reducing cost and provided a solution of balanced power for the future development of wireless communication. Modern wireless communication standards lie a bandwidth variation, modulation and duplexing, those requires the most stringent necessity of SDR specification.

In fact, the purpose of applying wireless communication techniques is to find reliable and cheap communication with the maximum possible use of channel resources. The channel allows transmitting information from the source to the corresponding destination. However, such channel may cause some noises, interferences and distortions, where these problems must be considered with the design of a transmitter

and receiver end technique. As well, both the bandwidth and power efficiency must be taken into account with ensuring low implementation complexity [3]. To get a successful transmission, a carrier frequency is created to modulate the imported signals to the transmitter containing the target information. This carrier frequency also increases the coupling power level to an antenna [4-6]. Practically, when the input signals are not compatible to the medium one, such signal is then utilized in modulating sine wave signal with higher-frequency, which is in a compatible frequency spectrum with that medium. This signal in turn is known as a carrier, while the circuit that allows the modulation of the carrier by a low-frequency signal is known as a modulator [6, 7].

Transmitter is a part of a communication network that accepts input signals, arranges the transmission of information on a specific link of transmission and increases the output power in order to result a successful transmission. It generally composed of oscillator, which produces a carrier frequency and a buffer amplifier that offers a high impedance load to reduce drifts and modulated using amplified intelligence signal [8]. A receiver represents the communication system destination end that is able to recover original transmitted information. It receives the transmitted signals, amplifies and filters them to remove undesired signals and then retrieves the original information. It generally composed of a Radio Frequency (RF) amplifier, oscillator and mixer [9]. These components are the receiver front end, which allows setting the receiver noise figure. Specifically, the RF amplifier must have a low noise design since it is used to amplify low-level signals including noises from the antenna. There is also a rhombic antenna at the amplifier input terminal to receive transmitted signals and surrounding ones, in which they must be separated [8].

Frequency Shift Keying (FSK) is one of digital modulation techniques that is used in wireless communication. It is a frequency modulation that uses modulating wave shifts to choose one of two recognized frequencies to the corresponding output [10, 11]. These frequencies are called the space, which associated with zeros and mark, which associated with ones [12].

The FSK has a narrow bandwidth, which provides a slight enhanced noise performance when compared to analog modulation schemes. But, it has a larger number of transmitted sidebands that offer more enhanced fading characteristics. The output frequency of the FSK is related directly to the logic condition corresponding to the binary input signal. The basic concept of the FSK, which is the most deployed digital modulation type when a high frequency spectrum is considered, is the transmission of digital information based on varying the carrier signal frequency.

Practically, the main idea of the modulation and demodulation of digital signals is the processing of converted digital symbols into waveform in a way that is efficiently related to the transmission channel properties. The application of the FSK model permits transforming such symbols into regular frequencies related to a steady duration, which is known as baud-rate. It is in turn stands for the number of symbols for each second. Particularly, several factors are considered to segment the FSK model into different classes, where the main factors are the symbol number, the correlation among related frequencies and the such frequencies phase. Modulation techniques are a crucial role since they define data that must to be transmitted.

The FSK demodulator recovers the original message from the modulated waveform [13]. On the other hand, after receiving the modulated signal by the corresponding receiver, the demodulation process is carried out. The demodulation then processes the modulated carrier signal to get the original data or in formations [14].

This study proposes HackRF One based Software-Defined Radio (SDR) to transmit digital data using FSK scheme. HackRF One is a hardware platform of SDR which is available in the market. It is catagorized as mid-range hardware which is also compatible with open source of software platform to implement SDR. GNU Radio is proposed to simulate radio communication process, where it allows measuring and evaluating the model performance. The FSK scheme is selected in this work due to its simplicity in both the modulation and demodulation as well as due to its inherent insensitivity to the nonlinearity of communication systems.

## **1.1. PROBLEM STATEMENT**

This research is conducted with considering the following problem statements:

1. How to implement SDR using HACKRF One to transmit FSK signal?
2. How is the performance of HACKRF one to transmit FSK signal?

## **1.2. OBJECTIVE OF STUDY**

The present research is purposed to:

1. To design the SDR implementation using HACKRF One to transmit FSK signal.
2. Evaluate the performance of HACKRF One for FSK signal transmission.

## **1.3. CONTRIBUTION**

The SDR is a key of wireless technology, which enables flexibility of hardware, power and price. It has been taken of a novel of wireless technology to be reached in any market range. There are many offers fairly SDR hardware in the market. It gives the public possibility to bring wireless device and program it based on their needs with a simple hardware. HACKRF One is mid-range SDR hardware with fairly price of US\$300 which offers transmitter (Tx) and sentr (Rx) functionality. The FSK digital modulation is applied for radio spectrum having high frequency range. This study is expected to give reference to design the transmission of FSK signal through HACKRF one as mid-range system. It is also looked forward the performance of the FSK signal generation using HACKRF One.

## **1.4. RESEARCH OUTLINE**

The report is preseted as following outline:

Part 1: This chapter presents introduction which consist of background of the study, problem statement, objectives, and contribution of the study.

Part 2: This chapter consists of literature review related to SDR concept, FSK scheme, hardware and software platform.

Part 3: This chapter explains about the proposed method design and implementation.

Part 4: This chapter describes the experiment results and its discussion.

Part 5: This part is conclusion.



## CHAPTER 2

### LITERATURE REVIEW

Software-defined radio and its implementation including the transmission schemes within SDR system have gotten great attentions either scholars or engineers. There were a lot of studies have been carried out in order to develop this wireless communication system since its concept introduced. They investigated and proposed digital modulation and demodulation techniques for digital communication systems. The FPGA was used in [15] to design various digital techniques with the aid of different approaches and tools. Three modulators were basically implemented in VHDL using Xilinx and Modelsim, namely; ASK, PSK and FSK modulators. Furthermore, such modulators were then designed by the MATLAB. Researchers discussed that each modulator has its own benefits and challenges and their use is based on the application.

Researchers in [16] focused on the Digital Pulse Width Modulator (DPWM) and introduced that its resolution increased by a on-time/off-time modulation constantly control in comparison with constant frequency modulation. But, this modulation control method increases also the switching frequency under weighty conditions of the load, respectively. Thus, switching losses occur as well as the needed for more efficient controller increases. Therefore, researcher introduced an advanced PWM technique using such control method for a buck converter of dc/dc as a solution for high switching losses and frequency. Results proved the ability of this technique to decrease the converter switching frequency and enhancing the modulator efficiency and resolution.

Researchers in [17] provided a tutorial about the use of SDR and presented applications constructed using GRC. The purpose of such tool kit is to offer a realistic experience in the field of communication and its concepts, such as signal

operations, digital and analog modulators, signal generations and multiplexing schemes using GNU radio. The GNU radio differs from the Labview and MATLAB in being an open source with easily obtained concepts and less programming concepts.

Researchers in [18] focused on the digital discontinuous PWM generalized technique, which is an advanced method when the inverter switching losses on any embedded system are considered. The work was based on carrying out an optimal choice at each sampling period to clamp a half bridge. When compared with traditional DPWM, this advanced version outperforms them in its low computation time, operation under both dynamic and steady-state operating conditions and independence on the load power factor. Researchers verified their algorithm using simulation and results proved its effectiveness with considering a starter-generator application with a resistance-inductance load.

Researchers in [19] used a compression technique called Delta Modulation (DM) with considering a Photo-Plethysmo-Gram (PPG) signal with high resolution. It was based on assessing the impact of step size on the DM performance in order to hold clean PPG signals and those influenced by motion artifacts. Consequently, this enhances the technique before using it in any data acquisition system. A 16-bit ADC was used to record PPG signals with 1000 Hz sampling rate. The Percentile Root Mean Square Error (PRMS) with and without DC component was estimated to consider the impact of the PGG DC and AC during assessing the performance. Based on the results, the PRMS with DC was lower than that without DC for all step sizes.

## **2.1. THE CONCEPT OF SOFTWARE DEFINED-RADIO**

The definition from wireless innovation forum (formerly SDR forum) states: A software-defined radio is a radio in which some or all of the physical layer functions are defined by software. A main characteristic of SDR is the ability to be compatible with various different waveforms [20].

Joseph Mitola presented it as an identifier for a specific radio class with an ability to be reprogrammed using software. It was composed of an ADC located at the receiver and a DAC at the transmitter with simple transmitting and receiving antenna, in which other functions were carried out by software. The first real application of the SDR was in soldierly radio systems to assist in integrating several radio channels in a certain frequency bandwidth. In the following decades, several developments were presented for the SDR, where it now offers a support for both digital and analog radios with a support also for their particular protocols and standards [21].

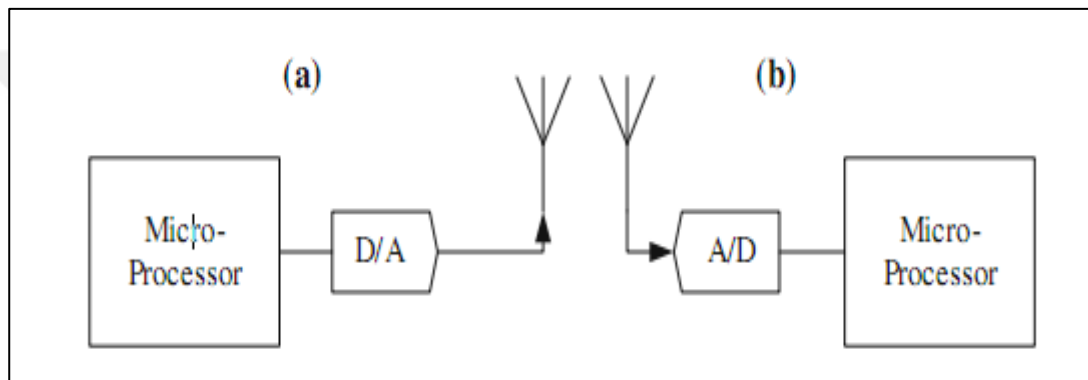

Figure 2.1. Transmitter and receiver of ideal software defined radio [13].

Figure 2.1 shows the general representation of the SDR. The data of users are included in the specified waveform within the microprocessor. The digital samples are converted directly into an RF signal and sent to the antenna. The receiver antenna capture the transmitted signal and then digitization and processing are applied on it using a specific processor. Ideally, the SDR must be able to support all types of waveforms for any bandwidth and carrier frequency.

Almost all radio functions, such as modulation, multiplexing, amplification, super heterodyne mixers, multi-access and other transmitter and receiver processes are performed within software. The software should be capable to complement new air interfaces without reloading the entire set of software. Traditional radio hardware are replaced with a software in SDR. Furthermore, in the digital domain, intermediate frequency (IF) sampling based SDR radios are able to carry out more signal processing than in the analog domain. Figure 2.2 shows the flow of typical data

in a software-defined radio system. The nearly entire processing of baseband signal on both Tx and Rx ends is undertaken in the domain of software [22].

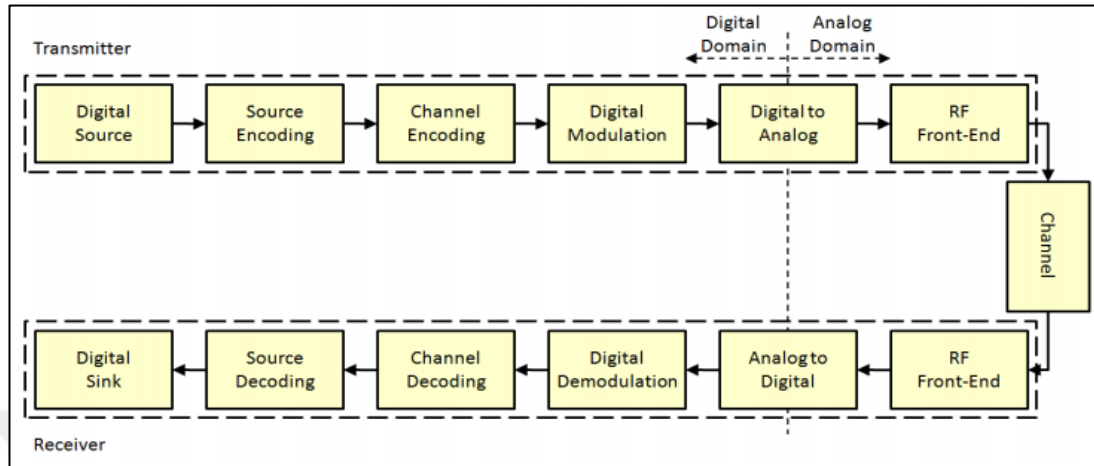

Figure 2.2 . Software-defined radio block diagram.

Digital domain performed in software and analog domain performed in hardware. Particularly, a specific smart antenna is used to implement the receiver to offer a gain against direction characteristic in order to decrease noises, multipath and undesired interfaces. This antenna offers the same benefits at the receiver side. One essential point is that the signal digitalization is performed near that antenna at the receiver based on deploying the ADC. Similarly, the signal is converted into analog domain as late as possible in the transmitter using DAC.

In the signal digitization, the IF range is considered to carry out the process. Practically, this solves the problems of the carrier offset and the involved imaging in this process with the use of a super-heterodyne approach that deployed in traditional radios. In the transmission route the DAC is interfaced to process the digital hardware by the channelization and sample rate transformation processes, while at the receiving route, this is performed based on interfacing the ADC. Generally, the baseband processing is carried out with deploying various techniques, such as the DSPs, "General Purpose Processors (GPPs)", "Application Specific Integrated Circuits (ASICs)" and "Field Programmable Gate Arrays (FPGAs)". On the other hand, several software methodologies are deployed to modulate/demodulate signals, as middleware and the "common object request broker architecture (CORBA)"

Some features of Software-defined Radio are as follows:

1. **Reconfigurable:** the SDR has a reconfigurable architecture that offers several communication standards to co-occur on general hardware. Therefore, it offers efficient wireless abilities and features to radio systems with no need for using new hardware.
2. **Reprogrammable:** various waveforms and protocols can be used to effectively reprogram the SDR. With considering mobile communication, it is simple to upgrade the software functionality over the air, where this is helpful and suitable for both the service provider and subscribers.
3. **Multi-featured:** the SDR permits multiple modes, standards, band features for one device.

SDR technology development and escalation is believed to revolutionize communication technology. One of SDR benefit is the flexibility to support multiple standards. The extraordinary of SDR is capability to configure device, which may be used by various communication systems (e.g., cellular phones, wireless-fidelity (WI-FI) transceivers, frequency modulation (FM) and analog modulation (AM) radios, terminals of satellite communications). It means that one hardware piece will be configured to perform multiple functions. The platform re-configurability will ensure hardware reusability. Re-programmability system enables hardware reuse until the next generation of hardware platforms available. These SDR characteristics consider as efficient system in cost especially. Manufacturers will not be limited to reduced hardware platform set and large commercial production will set into lowered costs.

## **2.2. FREQUENCY SHIFT KEYING (FSK)**

Digital modulation and demodulation processes the digital symbols which are transformed into waveform that is compatible with the characteristics of transmission channels. Frequency Shift Keying (FSK) scheme enables to convert the digital

symbols into distinct frequencies for a constant duration. The constant duration is known as the baud-rate that generally is defined as the number of digital symbols per second. Frequency Shift Keying is divided based on the number of digital symbols, the corresponding frequencies correlation and the phase of frequencies.

FSK is the most popular digital modulation form in the high-frequency spectrum [23]. FSK generally is classified into Binary FSK (BFSK) and M-ary FSK. The difference is the number of digital symbols where the BFSK has the number of different digital symbols equals to two and M-ary FSK has number of signaling more than two. Binary FSK is classified into Coherent and Non-coherent. The coherent one has the phase of the tones  $s_i(t)$  describing each symbol that is selected based on the tone phase describing the previous symbol. The transmitted signal phase can remain continuous. Non-coherent has no continuity of phase where the phase of the tones describes two successive digital symbols which are independent one another.

### 2.2.1. Binary Frequency Shift Keying (BFSK)

Binary FSK (BFSK) is a modulation scheme to send digital information among digital equipments. This scheme allows transmission of the data by frequency switching of a continuous carrier in a binary manner to one or other of two discrete frequencies. One frequency is designated as the ‘mark’ and another is as ‘space’ frequency. In the modulation of BPSK signals, the RF carrier phase is shifted by  $180^\circ$  based on the digital bit stream, where zero stands for a transition, while one stands for a phase transition. Thus, the carrier phase changes in a binary form, while both the amplitude and peak remains constant with the change in phase. Figure 2.3 describes the correlation between data information and the signal being transmitted [24].

A modulated signal of BFSK uses two tones with distinct frequencies  $f_0$  and  $f_1$  in delivering a binary 0 or 1:

$$x_0(t) = A \cos(2\pi f_0 t + \theta_0) \quad kT_s \leq t < (k+1)T_s \text{ for binary 0}$$

$$x_1(t) = A \cos(2\pi f_1 t + \theta_1) \quad kT_s \leq t < (k+1)T_s \text{ for binary 1} \quad (2.1)$$

$T_s$  is the symbol or bit period, and  $\theta_0$  and  $\theta_1$  are arbitrary phases.  $P_{fsk} A^2/2$  is the signal power.  $\theta_0$  and  $\theta_1$  are not equal phases in the event, further the signal is stated to be discontinuous or no coherent. This FSK modulation type is not common. The common type is coherent FSK modulation in which the phases  $\theta_0$  and  $\theta_1$  are equal ( $\theta_0=\theta_1=\theta$ ).

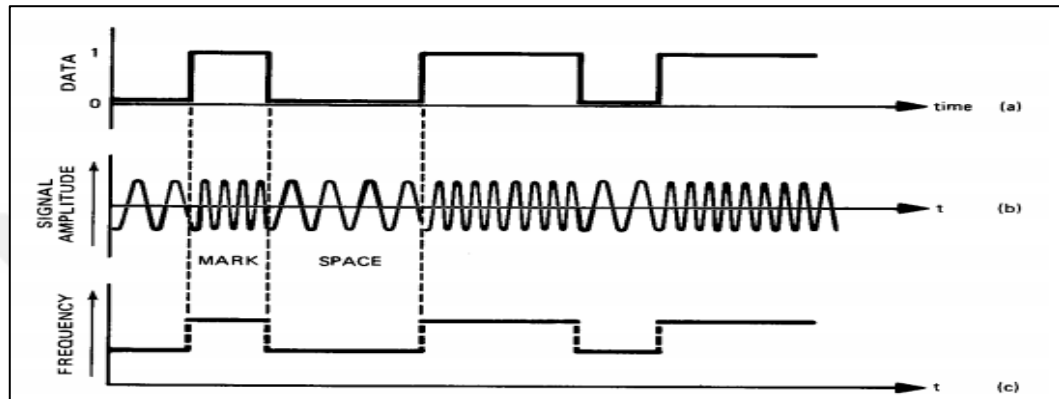

Figure 2.3. BFSK modulation, a) Binary data; b) Modulating frequency of FSK Signal production, c) Frequency characteristics.

Demodulation is a process to recover the original digital data from the modulated waveforms. There are two method to demodulate FSK signal which are synchronous (coherent) and asynchronous (non-coherent). Coherent method needs the carrier phase knowledge because it involves have multiplying received signal of the same phase and modulating signal frequencies which is used in FSK signal modulation. Coherent method or detection gives better demodulation results than non-coherent method. Non-coherent makes envelope detectors usage and allows simple circuicity to implement it. The frequencies  $f_0$  and  $f_1$  are chosen to enable coherent FSK demodulation as follows:

$$r(t) = \int_{kT_s}^{(k+1)T_s} x_0(t)x_1(t)dt \cong A^2 \int_{kT_s}^{(k+1)T_s} \cos(2\pi f_0 t + \theta) \cos(2\pi f_1 t + \theta) dt = 0 \quad (2.2)$$

Parameters of FSK signal are described in figure 2.4. Minimum duration of a mark or space is known as length of element which has values between 5 and 22 milliseconds. Frequency measurements of FSK signal are usually delivered in shift

and center frequency. Both the center frequency and shift are used to describe the FSK signals and its measurements. The minimal center frequency locates at the halfway among both the space and mark frequencies, while the shift stands for the difference in frequency among them and it is mainly in the range 50-1000Hertz. Irregularly, these signals are described using the deviation, which is the difference among one of those frequencies and the center one or the half of the shift.

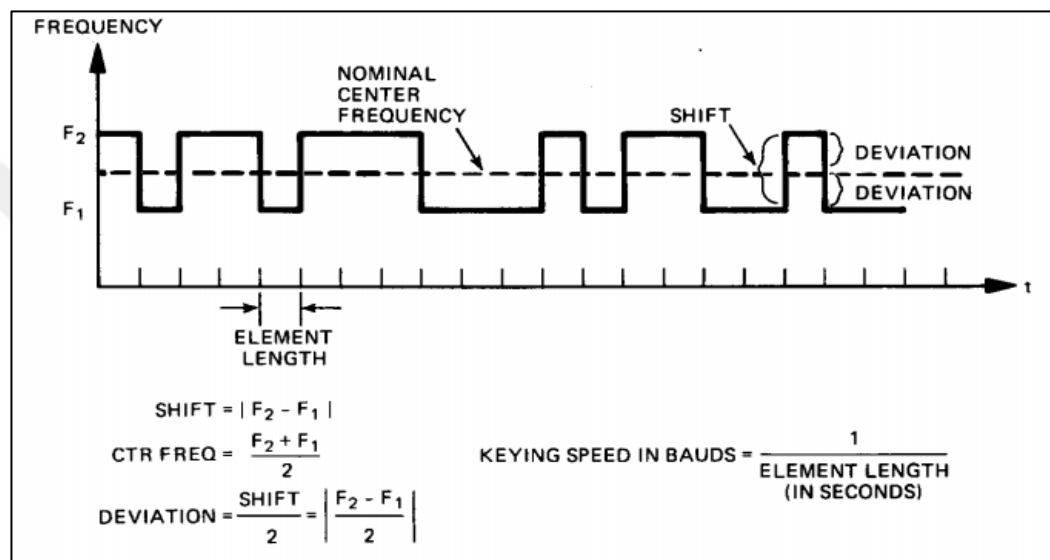

Figure 2.4. Parameters of FSK.

There are two manners to transmit FSK signals; coherent and non-coherent. The first manner involves that each space/mark tone phase is in a constant relation with a specific reference. Practically, this is the same as the production of FSK signals based on the switch among two constant oscillators to generate both the space and mark frequencies. However, there must be an interrelation among the keying and shift rate due to the continuity of transitions among the space and mark. Although the coherent method can offer efficient error reduction, the non-coherent one is generated more simply and can be deployed for most of the FSK transmissions. It does not in turn have constant relations among consecutive elements, where the phase changes in a random manner.

Figure 2.5 and 2.6 describe typical coherent FSK signal waveform with discontinuous and continuous phase with their relative spectra. The main difference

between both phase is the wide range of the spectrum at former over the latter. The spectral containment property of continuous phase FSK makes it a more desirable signaling scheme.

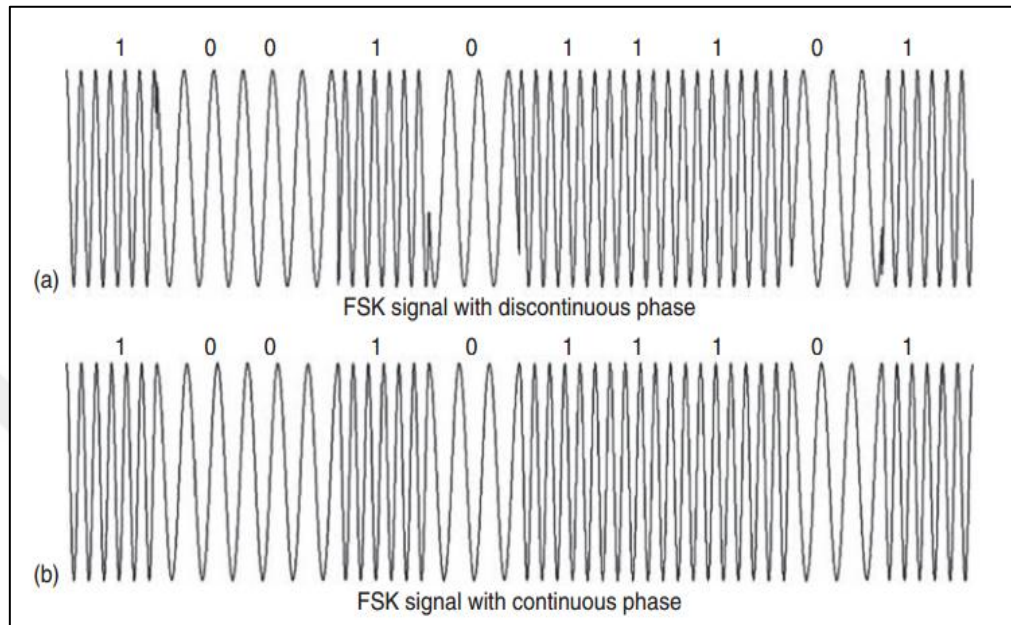

Figure 2.5. FSK signal waveform; a) Discontinuous phase waveform (non-coherent) and b) Continuous phase waveform (coherent).

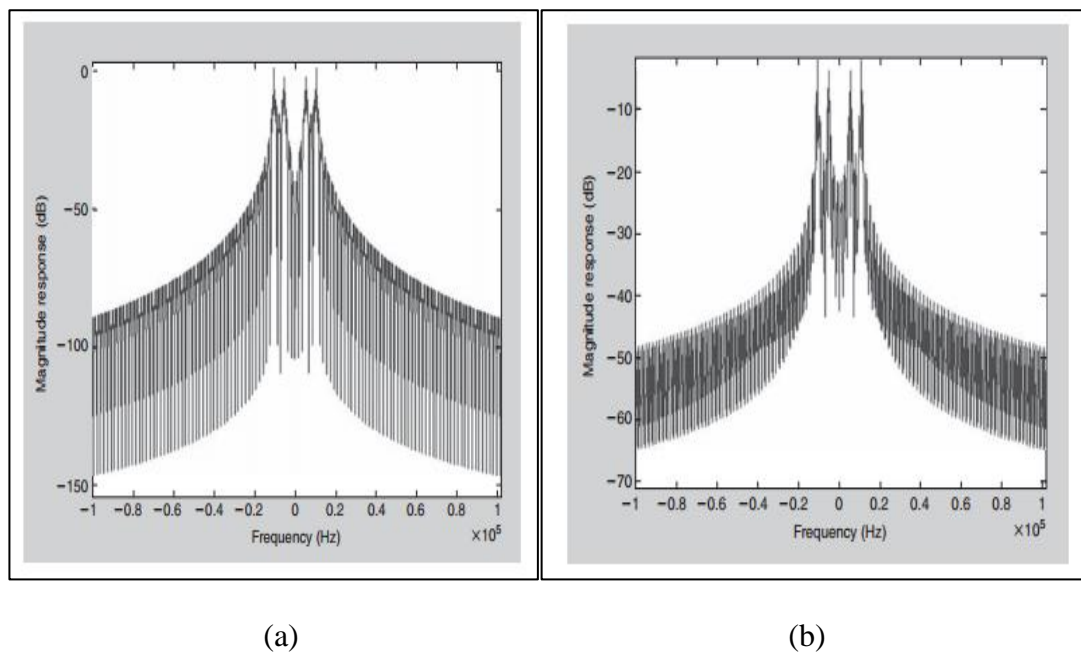

Figure 2.6. Spectrum of FSK waveform; a) Continuous phase spectrum b) Discontinuous phase spectrum.

### 2.2.2. M-ary Frequency Shift Keying (MFSK)

BFSK extension is M-ary FSK. It has more than two carriers. These carriers can be orthogonal or not, but the orthogonal could result better BER [25]. M-ary FSK requires larger bandwidth but BER decreases along with the increase of M's number. The coherent modulator of binary FSK can change to coherent M-aryFSK. It can be seen in the figure 2.7. The frequency synthesizer produces M signals by using the particular frequencies that have been designed and the coherent phase, further the multiplexer will pick one of them by the  $n = \log_2 M$  bits.

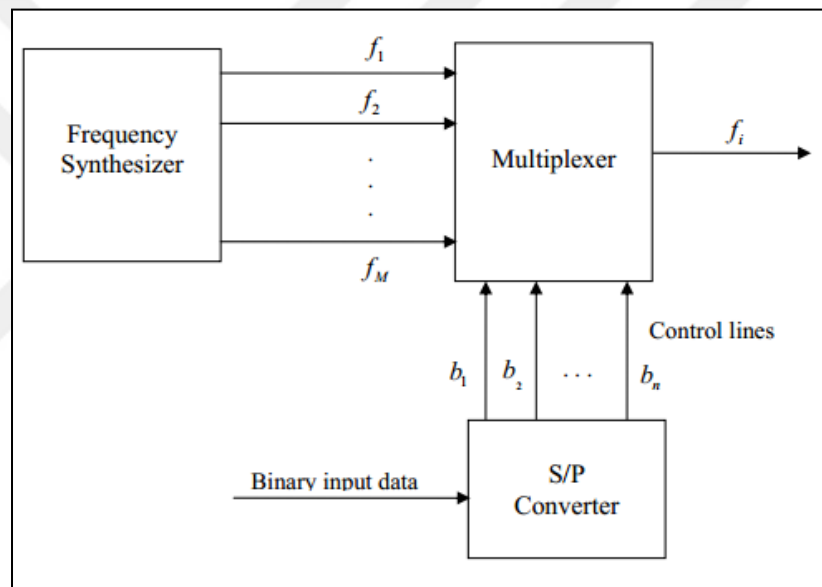

Figure 2.7. M-ary FSK modulator.

The demodulator of coherent M-ary decends in the general form of detector for M-ary equiprobable, equal-energy signals with known phases. The demodulator is a M correlator bank or matched filters.

### 2.2.3. Gaussian Frequency Shift Keying (GFSK)

Gaussian frequency shift keying (GFSK) is a typically modulation scheme that usually applied in various standards such as Bluetooth, DECT and Wavenis. The digital transmission derives from symbols translation which is usually known as a

discrete alphabet where the symbols translation then transforms into a signal. This transmission generally is transferred through medium. The Rx side will capture the signal and then recover its original symbols. The symbols are known as bits while the alphabet has only two symbols that is 0 and 1. The modulation method is a variant of frequency modulation (FM) of some carrier frequency  $\omega_c$ . 2-FSK carries the data by decreasing the carrier of the 0 symbol duration and increasing the frequency of the 1 symbol duration. GFSK is generated by adding Gaussian filtering to the square-wave signal which function to shift the frequency of carrier. Figure 2.8 is general GFSK diagram.

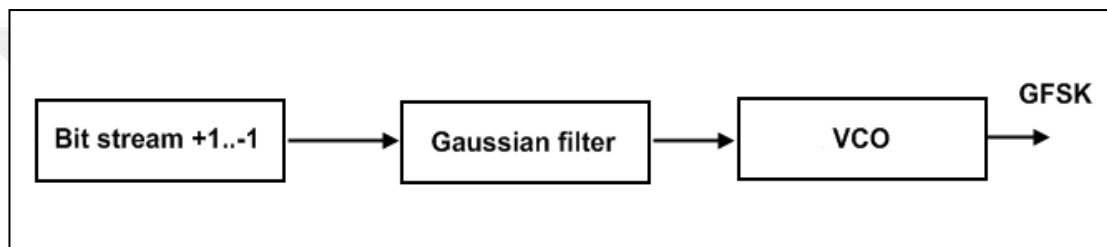

Figure 2.8. General GFSK diagram.

The high-frequency components are reduced in the output spectrum of the modulated signal because there is variation of the continuous phase of CPSK signal which is being modulated. Pulse-Shaping Gaussian Low Pass Filter establishes baseband signal half-sinusoidal shape before being modulated in order to get smooth phase trajectory of the FSK signal. This way also produces stable variations of instantaneous frequency over the time. It has some advantages as follow:

1. This system provides a constant envelope of the modulated signal. There is no need regeneration of spectrum to operate GFSK signal with the power amplifier of class C. It consequently consumes lower power which means better power efficiency.
2. It produces a narrow Main Lobe and a lower level of spectral Side Lobes of output spectrum. It has high spectral efficiency because of contiguous channel interference into low levels. It is crucial for a band limited channel and the non linear channel.

3. The GFSK modulated signal can be demodulated by Non-Coherent Demodulation schemes leading to low-cost GFSK receivers [26, 27].

The important purpose of lowpass filtering before modulation is the transmitted spectrum minimization of the FSK modulated transmitted signal. The other important advantage is that the lowpass filter has a well-behaved time-domain response. A Gaussian Filter is a class of filters that has a well-behaved time domain response. The frequency response of a Gaussian Lowpass Filter is 'Gaussian' in nature, following the following relation:

$$H(\omega) = \tau \sqrt{2\pi} e^{-\frac{1}{2}(\tau\omega)^2} \quad (2.3)$$

where:

$\omega$  = frequency (in radians/sec)

$\tau$  = constant

That is the Gaussian shape or Normal Probability Density Function. A typical filter with a Gaussian frequency response is that has Gaussian time-domain or impulse response also [27].

The Gaussian Filter has impulse response which is generally well-behaved, there are less noise or no overshoot. But the filter frequency response becomes slowly. Time domain response of a filter is better with the gradual frequency domain response. Gaussian filters are the most gradual frequency-domain responses of any analog filter type which has linear frequency-domain response of the Gaussian Filter. So that the phase of the Gaussian filter is consequently linear as well.

Algorithm of demodulation of FSK modulated signals are applicable to the GFSK modulated signals because the GFSK modulation is the modification of the FSK modulation. A matched filter is important to get optimum demodulation algorithm. A matched filter means that frequency response of the filter is designed to accurately match to frequency spectrum of the input signal. A matched filter operation is the same as correlating a signal with a delayed copy of itself.

### 2.3. SOFTWARE DEFINED RADIO HARDWARE PLATFORM

There are available two kind devices of SDR hardware which are functioned as transmitter and receiver. The transmitter hardware has usually receiver functionality or in other word transciever. SDR transmitters receive modulated data in form of baseband signal as an input and further will be generated by a DSP processing. It can be seen in the Figure 2.9 [28].

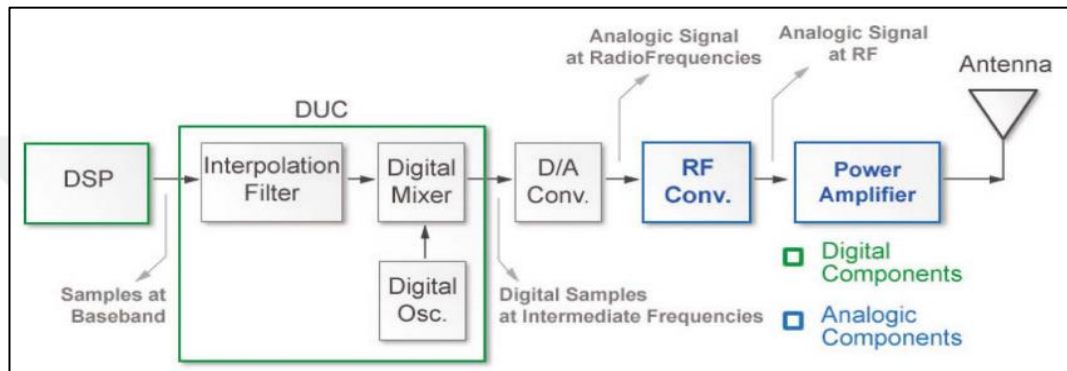

Figure 2.9. SDR transmitter block diagram.

A Digital Up Converter (DUC) placed on the first block. It is functioned to transfer modulated data or signal of the baseband to IF. Next, DAC transform the samples to the analog domain. RF converts the signal into higher frequencies. The signal finally is amplified and directed to the antenna. The Interpolation Filter is proposed to increase the baseband signal's sample rate in order to adjust the operating frequency of the components which is belong to. Furthermore, the Decimator's reservely operation is performed in architecture of the receiver. The samples are delivered to IF by digital mixer and local oscillator and the local oscillator also will control the shifted samples. Some hardware of SDR which is available in the market is shown on the Table 2.1.

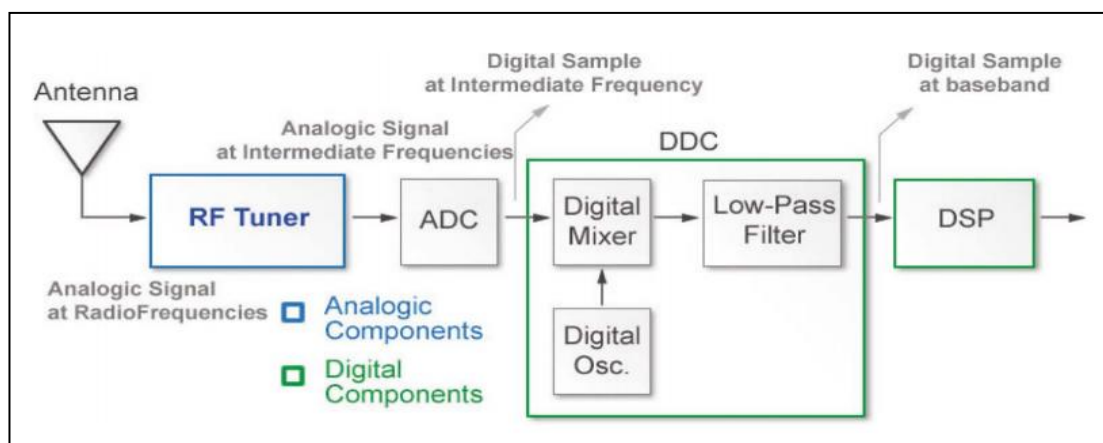

Figure 2.10. SDR receiver block diagram.

Figure 2.10 describes a SDR receiver block diagram. Initially RF tuner functions to convert the analog signal to intermediate frequencies. The IF signal further proceed to the ADC converter in transformation of the signal's domain and switching digital samples at its output. The samples become feed to the next stage's input which processes on a Digital Down Converter (DDC). The DDC is usually a monolithic chip and it is the key part in receiver side of the SDR system. It consists of three main components which are a digital mixer, a digital local oscillator, and a Finite Impulse Response (FIR) low-pass filter. The Digital Signal Processing (DSP) block receives baseband samples, further demodulating and decoding tasks are performed within DSP block [28].

Table 2.1. Available SDR devices in the market.

Commercial Name	Min. Freq. (MHz)	Max. Freq. (MHz)	Band width	Resolution of the ADC	Transmit?	Price
RTL-SDR 2831	24	1766	3,2	8	No	10 -20
FuncubePro	64	1700	0,096	16	No	150
Funcube Pro+	410	2050	0,192	16	No	200
HackRF	1	6000	20	8	Yes	300
BladeRF	300	3800	40	12	Yes	400-650
USRP1	10	6000	64	12	Yes	700
MatchStiq	300	3800	28	12	Yes	4500

SDR hardware has become popular and is being widely deployed in the market, which has increased the popularity of this system since its introduction. Strong and complete-featured concepts in delivering instructions, either in the analog or digital communication areas, are the reasons behind its popularity. Those SDR hardware units which are widely available in the market offer a wide range of features and prices as well. There are three ranges of SDR hardware. The first is a high-end system of the Universal Software Radio Peripheral (USRP) platform that provides complete stand-alone radio systems. It is able to acquire and process large portions of the RF spectrum. The second, which is considered a mid-point system, is the HackRF One. It has features to receive and transmit, sample rates of up to 20 MS/sec, and operating up to 6 GHz. The third is a very modest system such as the RealTek RTL2832U stick. It has a sampling rate up to 2.4 MS/sec, operating up to 2 GHz. It has proper capability enough to perform SDR receiver [29].

### **2.3.1. Universal Software Radio Peripheral**

Universal Software Radio Peripheral (USRP) is a variant of high-end system SDR hardware. This series is able to operate as a stand-alone system which is an open source platform and has completely featured to perform SDR instructions. It can be functioned as transceivers. Besides, USRP has the ability to deliver DAC/ADC hardware with high performance that can be operated in a wide spectral bandwidth when coupled with a specialized wideband RF front end daughterboard. It should be noted that high-Q, narrow-band daughterboards are also available for ISM bands.

The USRP hardware architecture consists of a FPGA for digital up/down-conversion to/from the DAC/ADC for the IF signal to/from the RF daughterboard, respectively. This technique proposes for achieving highest resolution ADC/DAC conversion between the baseband and IF signals. The additional function of DSP can be also deployed through FPGA, although this may bring consequence where FPGA digital sample rate conversion performance is possible getting reduced.

Three models of USRP series are:

1. USRP Bus Series is the cheapest model of USRP series. The single transceiver B200 model prices below \$750. This model is connected to interface to the host through a USB 3.0 connection.
2. The higher priced model is USRP Network Series which priced near \$1500 and it communicates to the host via Gigabit Ethernet.
3. The USRP Embedded Series is stand-alone models which is able to perform full-functioned SDR and it is no need to be connected to the host on its operation. Being priced about \$1500, USRP Embedded Series E110 consists of a TI OMAPprocessor 16, an ARM Cortex A8 running at 800MHz and a TI C64 DSP in delivering its function. The ARM processor runs Linux that is completed with preinstalled GNU Radio. The models with additional features such as dual transceivers and upgrade processing capability are available at higher cost.

### **2.3.2. HackRF One**

HackRF One as middle range SDR hardware can perform transmitting or receiving functions but it cannot deliver both functions synchronously (half-duplex). The HackRF One is an open source hardware platform that can be programed for stand-alone operation or can be utilized as a USB peripheral. The architecture can be found on the Github Repository [20](#) so that the users are able to learn the schemes and improving the schematic as the users' desire. TheRF front end has RX/TX gain which programable and filter of baseband. The advanced applications, for example radar function, can also be deployed because HackRF hardware platform provides Clock In and Clock Out lines for timing synchronization across multiple devices.

RF and digital hardware components of HackRF One are placed within one PCB. A single out RF filtering is not easily swapped in and out because of that. So that the signals tend to diminish to noise ratio for many applications, as this device is meant to be used as a general purpose, widebandSDR. The custom built external front end filters is a technique that usually applied to take out a majority general purpose of

SDR. The reception is possible to be greatly improved for the bands of interest by additional filter placement between the antenna and the SMA input of the SDR.

### **2.3.3. RTL\_SDR**

There are two popular low cost SDR receiver hardware which are RTL-SDR 21 dongle and FUNcube Dongle 22 with significant online support communities. The RTL-SDR is based on the RTL2832U 23 IC that actually a reception IC of European TV. It employs a driver of modified software which is modified in particular form in order to function performing SDR. The chipset is used to be able to performed as USB interface, ADC, filtering and demodulation. The RTL-SDR dongle includes an RF frontend tuner IC such as the Elonics E4000 that able to tune in signals from 24-1766MHz. The tuner will produce that signal at an Intermediate Frequency (IF) around 4.57MHz, which then the RTL IC will process it. This hardware is considered as the most effective in cost. RTL device can be purchased with not more than \$10 that even includes an antenna capable of operating over the tunable range.

The second one is FUNcube Dongle which can be purchased about \$175. This device is tunable over the frequency ranges of 150kHz to 240 MHz and 420 MHz to 1.9 GHz with a USB 2.0 host connection. The Funcube Dongle Pro+ (FCD) operates in much the same way as the regular FUNcube Dongle, with the E4000 Tuner IC at the frontend, but has better performance. The higher quality components are used for the ADC and LNA in the Pro+ device, along with a separate microcontroller. Both systems performs mixed RF spectrum directly to baseband frequencies by utilizing a direct conversion” or “zero-IF” SDR architecture technique which means there is no intermediate frequency is used. This method is different with the USRP and HackRF One, which utilizes mixing from passband to an IF, then downsamples or upsamples from the IF using the FPGA.

## **2.4. OPEN SOURCE SOFTWARE PLATFORM**

SDR system need a software that includes the ability to write custom routines in various programming languages such as C++ or Python or the option of using the

GNU Radio signal processing package to link the routines to the hardware. Graphical development tools such as GNU Radio Companion (GRC) or MATLAB Simulink is used for instructional purposes that enables to configure and link the communication blocks in creating communication systems. An open source modules are available to seamlessly and easily connect these communication system flow graphs to various compatible hardware devices with a low-cost antenna. Communication signals can be transmitted and received at the same time their characteristics can be examined on standard laboratory test equipment. Additionally, powerful and easy to use analysis tools such as SDR# augment the experience [29].

### 2.4.1. GNU Radio

GNU Radio is an open-source software toolkit that encompasses various blocks of signal processing that allow implementing SDRs effectively in a virtual simulation environment or with using exterior RF hardware. Its main application fields are in mobile communications, tracking satellites, audio processing, radar systems and commercial and academic environments to offer an adequate support for investigation in the wireless communications field and for practical radio systems [30]. As well, it is used to implement several band-restricted communication standards. The general representation of the GNU Radio is demonstrated in Figure 2.11.

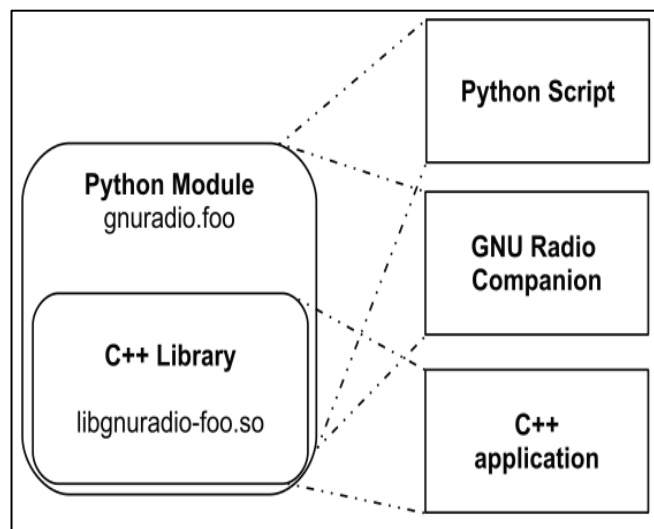

Figure 2.11. GNU radio.

Several processes are carried out by the GNU Radio, such as writing applications to allow receiving or pushing data from/to digital streams. In addition, there is a variety of demodulators, equalizers, decoders, vocoders, channel codes, filters and synchronization elements within it. As well, there is an efficient method to connect such elements and control the transmission of data among its blocks.

GNU Radio is able to handle digital information only, where mainly the input/output data of both the transmitter and receiver are complicated baseband samples. Thus, an analog hardware is deployed to get the target center frequency. Therefore, several types of data can pass among blocks, as bytes, bits, bursts and several complicated types. Basically, the Python language is deployed to write the applications of the GNU Radio, while the C++ is deployed to implement the signal processing path with deploying specific processor floating-point extensions. Therefore, developers can design radio systems with high simplicity, throughput and speed [30].

Python or C++ are programable language tools that able to write blocks of generated signal processing and add it to the signal chain. GNU Radio is considered as an impeccable software platform because the general signal processing applications and communications have already been written and optimized. This makes GNU Radio highly modular. GNU Radio also has featured with a run-time scheduler that able to optimize the data flow among processing blocks and creating a more robust test environment in real-time.

GRC is the graphical user interface for GNU Radio, where users set functional blocks into a processing chain or flowgraph. GRC application simplifies the way in develop communication system using GNU Radio. Blocks is used to create the most comprehensive functions of communication system. The users are expected to simply configure the block with a handful of parameters particular to the system. A user can create a custom graphical flow block (in either Python or C++); the blocks can be found via the user community and by default in GRC. Once a flowgraph has been created, the user generates a Python file with a click of a button in GRC, where the signal processing blocks (written typically in C++) are connected together, hence Python glue code.

The GRC blocks themselves are somewhat self-documenting in that any user can study the underlying code that creates the block to better understand its functionality. Many online tutorials are also available which explain most of the underlying idiosyncrasies of the program.

GRC provides drivers for many of the SDR transceivers that are exist in aneasily implemented “source block”. The source block is withdrawn into the flow diagram. Then it is configured according to preference of the user and based particular hardware which is used. All SDR devices that are mentioner in previous section have source blocks available both in GNU Radio and GRC, where most use the Osmocom source. Figure 2.12 shows the configuration foran Osmocom source.

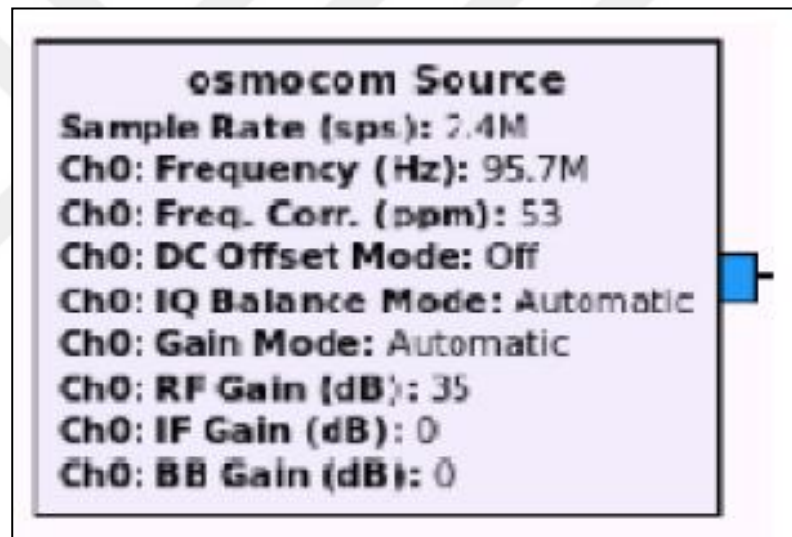

Figure 2.12. GNU configuration for osmocom source.

#### 2.4.2. GNU Radio Features

Signal flow graphs and source codes are basically generated using the GNU Radio Companion (GRC) tool. The most essential features of the GNU Radio are:

- It bundles the GRC.

- The ability to completely integrating the GRC into a desktop environment, which offers a support for desktop standards that are available for free, such as mime type and icons.
- Several Cheetah templates are utilized by the GRC in order to produce a source code using the python for a flow graph. Thus, a source code can be produced for non-GUI and WX GUI flow graphs.
- Documentations can be simply extracted for the blocks of the GNU Radio using doxygen-generated xml files
- The flow graph can include variable blocks, which map specific variable names to specific values. As well, various graphical variable blocks are included in the GRC to permit producing WX GUI flow graphs.
- There is a related xml file for each GRC block, which includes specific template, IO ports and parameters, in which there is a match among the variable name and the GNU Radio block one to enhance the portability. The definitions of all blocks are authenticated upon execution.
- Any change in the definitions of blocks and variables causes a change on the flow graph files structure. This is mainly conducted automatically by the GRC, but this is not completely accomplished in a correct way.
- Each block has two states; enabled/disabled, where it is enabled by default. In the disabled mode, the block is converted into a gray one and neglected by both the source code generator and validator. Furthermore, it is allowed to copy, paste and cut blocks among flow graphs.
- Hierarchical blocks can be generated by the GRC

### **2.4.3. C++ Programming Language**

C++ is a middle-level language and a general-purpose, assembled, statically typed, free-form and case-sensitive language supporting object-oriented, technical and generic programming. Its first introduction was in 1979 by Bjarne Stroustrup. Basically, it includes three portions; core language, standard library and "Standard Template Library (STL)". The core language offers all needed building blocks, such as data types and variables, the standard library offers several functions manipulating

strings, files and others and the STL provides approaches for manipulating structures of data [31]. The main features of the C++ are [32]:

- Simplicity.
- Portability.
- Powerful and syntax, platform and compiler based language.
- Case-sensitivity and utilization of pointers.
- Object oriented language.

#### **2.4.4. Python Programming Language**

Python is a high-level language, which was proposed initially in 1991 by Guido van Rossum. It has code readability and a syntax that permits expressing concepts by programmers using fewer lines than other languages, such as Java and C++. As well, it offers intended constructs to permit writing clear programs. Python offers an automatic memory management with an ability to support several paradigms, such as imperative, object-oriented, procedural and functional programming. Furthermore, it composed of a large standard library. The main features of the Python are [33]:

- General purpose and open-source language
- Functional, procedural and object oriented language
- Interfacing with other languages, such as Java, C and C++ by SWIG
- Effective interactive environment

#### **2.4.5. SWIG Software Development Tool**

Simplified Wrapper and Interface Generator or SWIG is a software development tool, which mainly deployed to associate programs implemented by C++ and C using various high-level languages and offer compatible codes with profitable and non-profitable projects. It is utilized with several languages, as Python, Ruby, JavaScript and other non-scripting languages, such as Java, R, C# and Octave. Moreover, it supports various compiled and interpreted scheme implementations, such as MzScheme/Racket.

In practice, the SWIG is the most utilized tool to make high-level compiled/interpreted user interfaces, programming environments and test C/C++ languages. Usually, SWIG is utilized in parsing /C++ interfaces and making the needed glue code to the languages mentioned above to call them into the C/C++ code [34]. The main features of the SWIG are:

- Generating wrapper codes for several languages, such as C#, Go, Java, JavaScript, Lua, PHP, Ruby, R, Perl and Python.
- Including global functions, variables, constants, pointers, structures, arrays with multiple-dimensions and variable length arguments.
- Memory management.
- Template instantiation.
- Class/structure extension.
- Ambiguity resolution.
- Extensive diagnostics including errors and warnings.

## **CHAPTER 3**

### **DESIGN AND IMPLEMENTATION**

#### **3.1. DESIGN CONSIDERATION**

Proposed method designed based several considerations as follow:

1. Flexibility: Proposed system is designed and implemented in order to get flexible design in implementing SDR system. It is expected to be flexible in:
  - Cost which means using affordable cost of hardware in the market, but still can perfoms transceivers with full featured system.
  - Re-configurability which means that the system can use to support any modulation, demodulation or other schemes.
  - Compatibility which means that the system compatible with any PC.
2. Open source: The source code of system must be able to modified or customized. Both hardware and software are open source platform which available in the market widely for anyone or all users of any levels.
3. Simplicity: The proposed method is designed with consideration that it will be simple SDR application either to be design or operated.

#### **3.2. SCOPE OF THE STUDY**

Proposed method is designed to get design a software defined radio system and implement it using mid-range available SDR hardware platform in the market. It is also proposed to deliver transmision using FSK modulation and demodulation scheme.

### 3.3. INSTRUMENT

#### 3.3.1. HackRF One

HACKRF One is an SDR bordering, which allows the radio signals transmission and reception in the range from 1 MHz to 6 GHz. This hardware is classified as mid-range systems with full-featured transceivers system. It allows developing and testing current and future radio technologies. It is also deployed as a USB peripheral or in other cases; it is programmed to get stand-alone operational systems.

Some featured HACKRF one specifications are: the half-duplex transceiver, 8-bit Quadrature samples, offering around 20 million samples in each second, well-matched with GNU Radio, hi-Speed and powered USB, interior expansion pin headers, controlled antenna port power, configurable RX and TX gain and SMA female antenna connector and IO clock.

Figure 3.1 illustrates the general HackRF One architecture. The schematics are available on the Github Repository 20. It can be studied in detail and improved as desire of the user. The RF front-end features a programmable RX/TX gain and baseband filter. Clock In and Clock Out lines are provided on the HACKRF One for timing synchronization across multiple devices when more advanced applications (such as radar) are to be used. HACKRF One will connect to a PC.

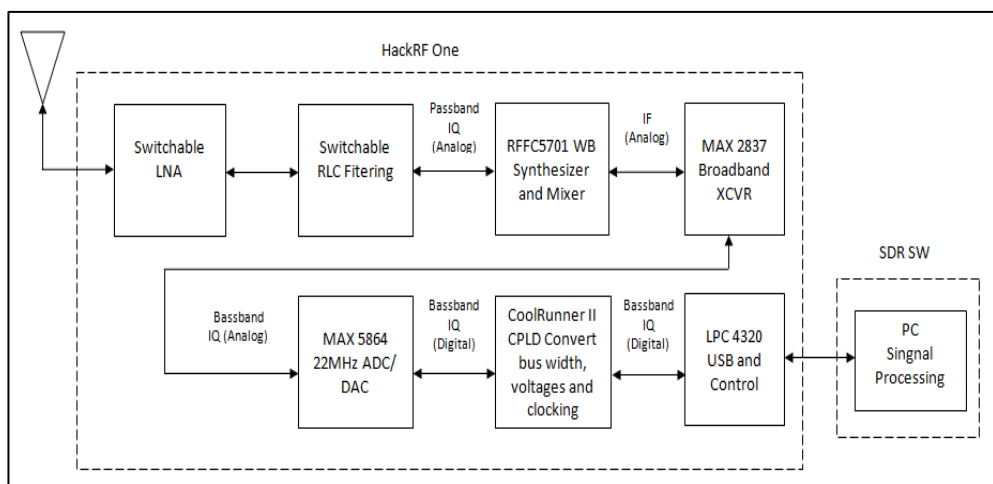

Figure 3.1. HackRF One architecture.

### **3.3.2. GNU Radio Companion**

All the signal processing is performed in GNU Radio including to create applications receiving data out of digital streams or pushing data into digital streams, which is proceed to be transmitted over hardware. GNU Radio has filters, channel codes, synchronization elements, equalizers, demodulators, vocoders, decoders, and many other elements in the GNU Radio jargon. Those elements are known as blocks which are typically found in radio systems. Method of connecting these blocks is important to manages the way of data is passed from one block to another.

Python is the major programming language to write applications in GNU Radio, while C++ using processor floating point extensions implemets the supplied, performance-critical signal processing path. The developer is able to implement real-time, high-throughput radio systems in a simple-to-use, rapid-application-development environment. GNU Radio Companion (GRC) is a graphical tool to create signal flow graphs and to generate source codes. GRC is usually bundled with GNU radio [24].

### **3.4. IMPLEMENTATION**

The proposed design in this project includes modulation and demodulation using SDR features. The presented modulation scheme is based on the Gaussian Frequency Shift Keying. It is deployed for such as amateur radio, caller ID and emergency broadcasts communication systems. The binary FSK (BFSK) is the simplest FSK, where it deploys a couple of discrete frequencies to send binary (0s and 1s) information. In such scheme, one denotes the mark frequency, while zero denotes the space frequency. On the other hand, the BFSK has a wide spectrum content that needs more bandwidth. The Gaussian frequency-shift keying (GFSK) basically filters the data pulses using a Gaussian filter to get smoother transitions. Such filter can decrease the sideband power and the interference with adjacent channels with increasing the inter-symbol interference. Furthermore, Gaussian filtering is a typical manner to decrease the spectral width so it is known as "pulse shaping" in this application.

### 3.4.1. Design Diagram

The proposed communication system in this project is shown figure 3.1 source not found. A music source, which is playing music continuously, is included. The signal goes to the transmitter that is modulated and broadcasted to the air. A nearby receiver then captures the signal, demodulates and reproduces the result in an audio sink.

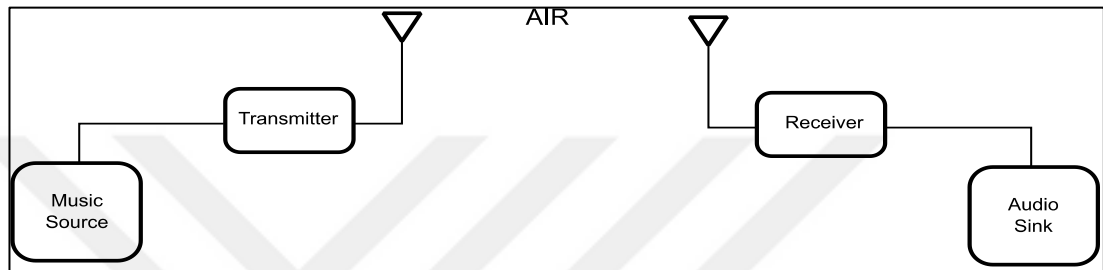

Figure 3.2. Proposed method diagram.

Figure 3.3 and 3.4 illustrate the general structure of transmitter and receiver subsystems.

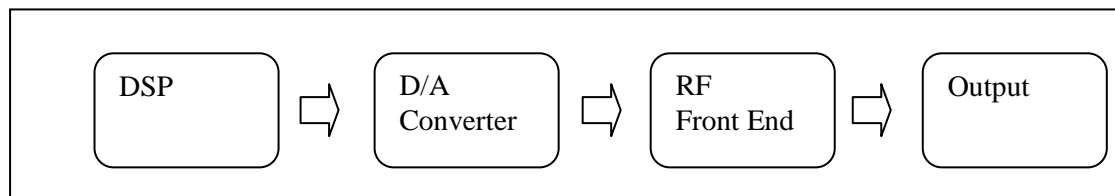

Figure 3.3. Transmitter subsystem.

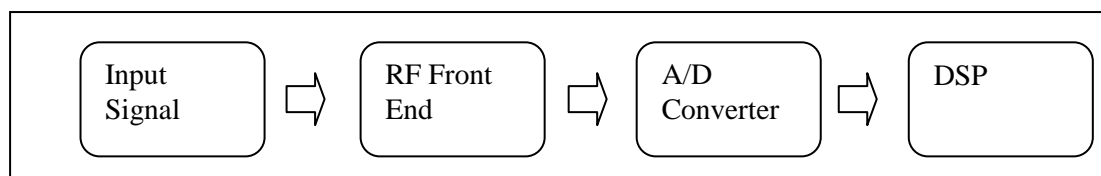

Figure 3.4. Receiver subsystem.

### 3.4.2. Requirement

The demonstration of the design does not require a significant amount of elements. Most part of the hardware can be seen in the Figure 3.5. The devices are needed for present study is as follow:

1. Two computer stations. One for transmitting design and other for receiving.
2. Two HackRF one. The hardware's have transmitting and receiving capabilities.
3. Two telescopic antennas.



Figure 3.5. Hardware setup.

Both computer need to have GNU Radio companion installed. It is important to highlight that GNU Radio installation does not include native support for HackRF one. Thus, it is needed to visit Great Scott Gadgets website and download the drivers required to make HackRFone compatible with GNU Radio.

### 3.4.3. Software Block Diagram

The GNU Radio design includes the transmitter and the receiver. The output frequency is 433 MHz in ISM band which is a free space to transmit. Figure 3.6 draws the transmitter block diagram:

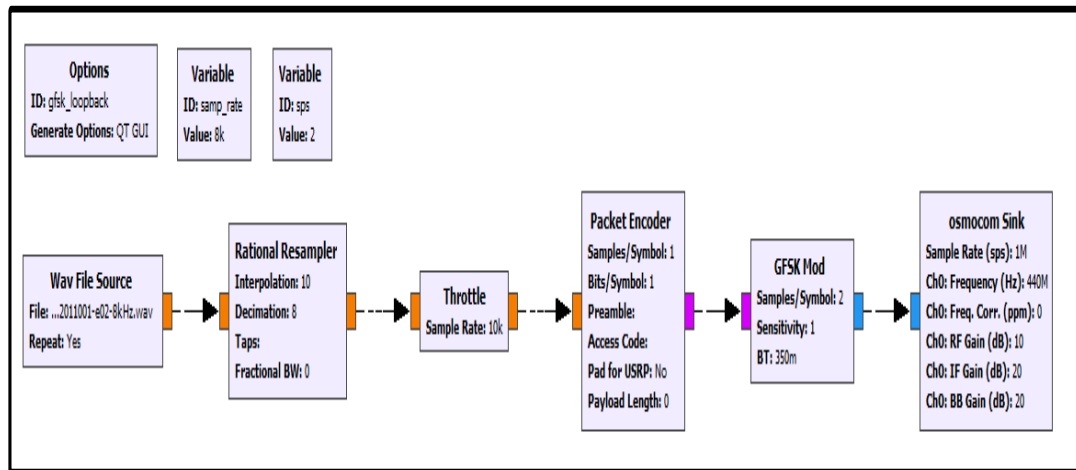

Figure 3.6. Transmitter block diagram.

Gfsk\_loopback was created as option to generate the interface engine (GUI) that would be rendering the results. Two variables of the transmitter which were sample rate 8k and sps with the value 2. The digital file source of this study was wav form with the interpolation and decimation value of 8. Throttle block with the sample rate 10k proposed to keep the sample rate constant when the hardware attached to a computer. Packet encoder was for an encoder and it controlled introducing structures for synchronization. GFSKMod was for modulating the GFSK signal with sample/symbol of 2, sensitivity of 1 and BT 350m. Osmocom sink used to link the interface with HackRF one to control the output with the sample rate of 1M, 440M frequency, RF gain of 10 dB, IF gain of 20 dB and BB gain of 20 dB.

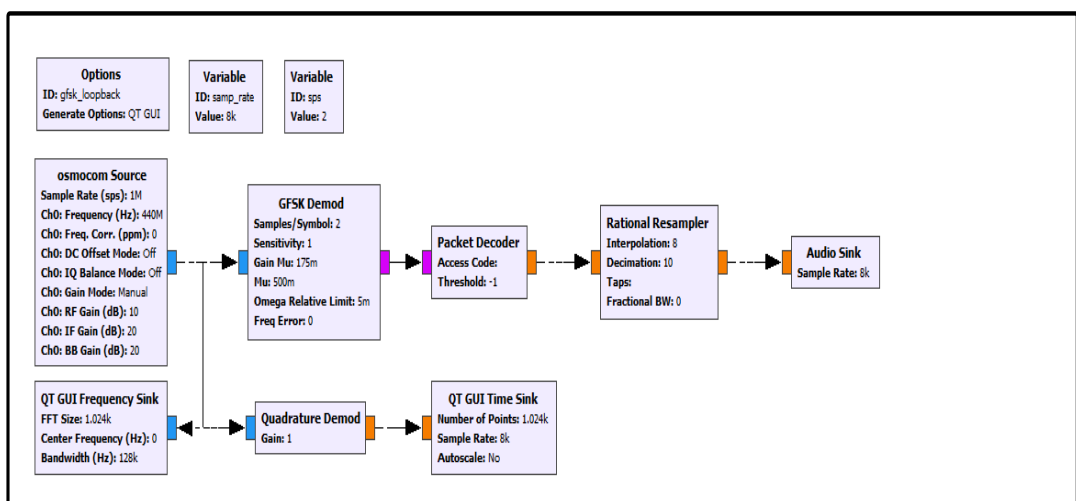

Figure 3.7. Receiver block diagram.

Figure 3.7 shows receiver block diagram. Osmocom source was interfacing HackRF one and working as input. The variables of this block were in line with the osmocom sink in the transmitter. GFSK Demod proposed to receive IQ signal and demodulated it with design of sample value of 2, sensitivity 1, gain mu about 175 m, Mu about 500 m and omega relative limit about 5m. Packet decoder received package transmitted and extracts the information with the threshold value of 1. Rational resample block has interpolation of 8 and decimation of 10 to recover signal into a suitable audio sampling rate. Audio Sink reproduced the received signal to the computer speaker with the sample rate of 8k. QT GUI Frequency sink block was designed with FFT size 1024k and bandwidth 126k to present the signal being received in the frequency domain. Quadrature Demod Gain was 1 to convert the complex signal in a time domain representation. QT GUI Time Sink block presented plots the signal on time domain into the interface. It designed with number of point 1024k and sample rate 8k.

## CHAPTER 4

### RESULT AND DISCUSSION

In this project, initial experiments are conducted with the GNU Radio design in order to evaluate the performance of the proposed system. The running of the designs described earlier presents some results through the window interfaces. The received signal frequency spectrum and time domain in real time are presented in the receiver. That way is possible to see the frequency and time domain signal from transmitter side. Figure 4.1 shows a sample of signal received in frequency and time domain.

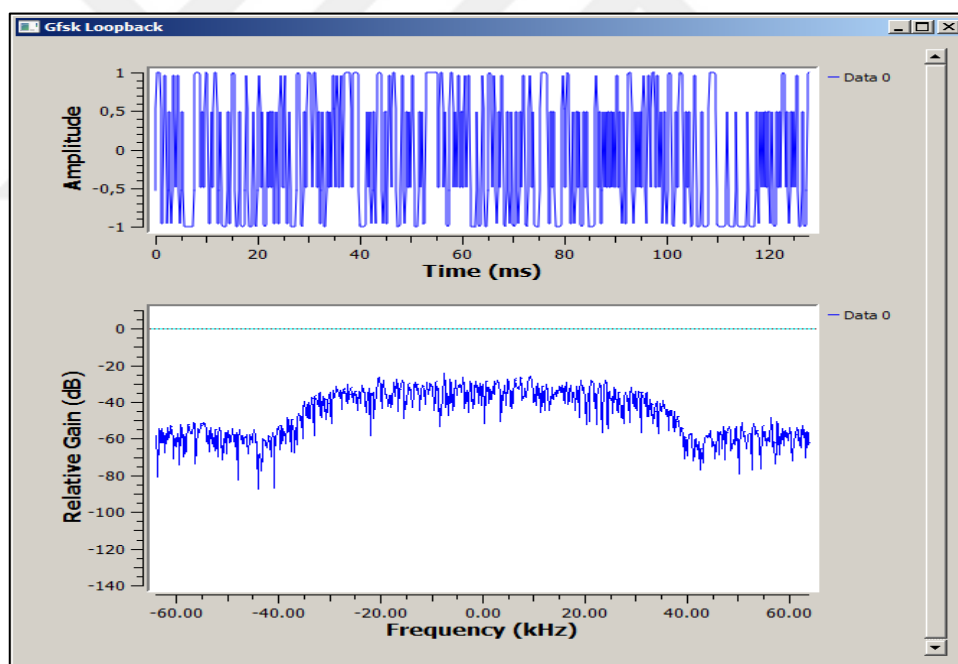

Figure 4.1. Received signal.

When there is no signal being received the spectrum, the power level of the noise spectrum is only illustrated. A regular pattern of the signal on time domain can be observed from the previous figure. If there is no signal being received the regular pattern of GFSK does not appear on the time domain interface. Figure 4.2 shows the result for absence of signal. Figure 4.3 shows the signal power measurements.

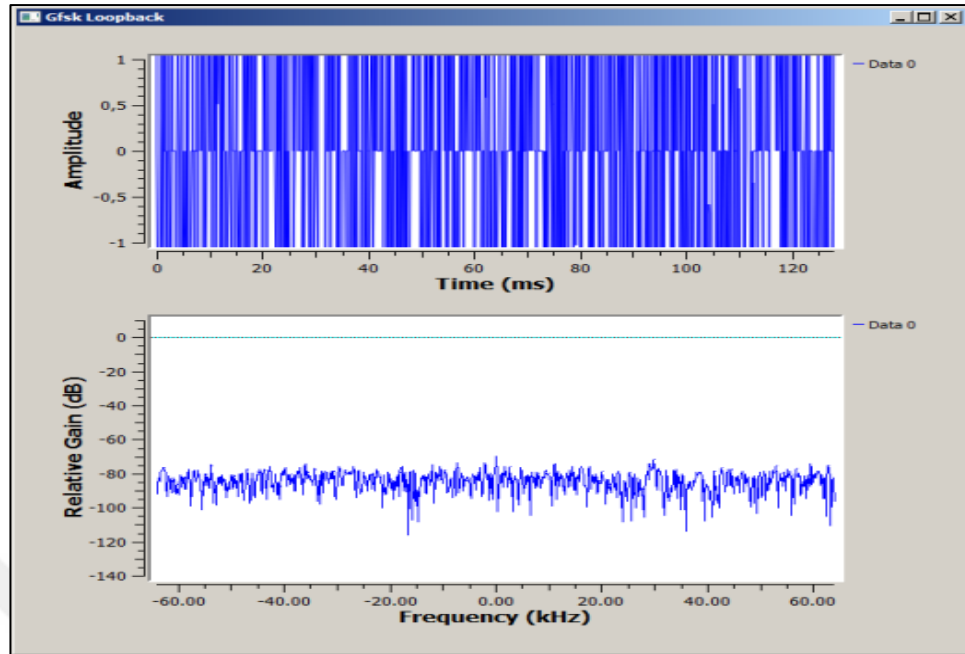

Figure 4.2. Absence signal.

Several environment measurements are performed in order to evaluate if the system works properly. The interface is deployed to measure the signal reception quality. There is 10 dB of signal being received in other simulation.

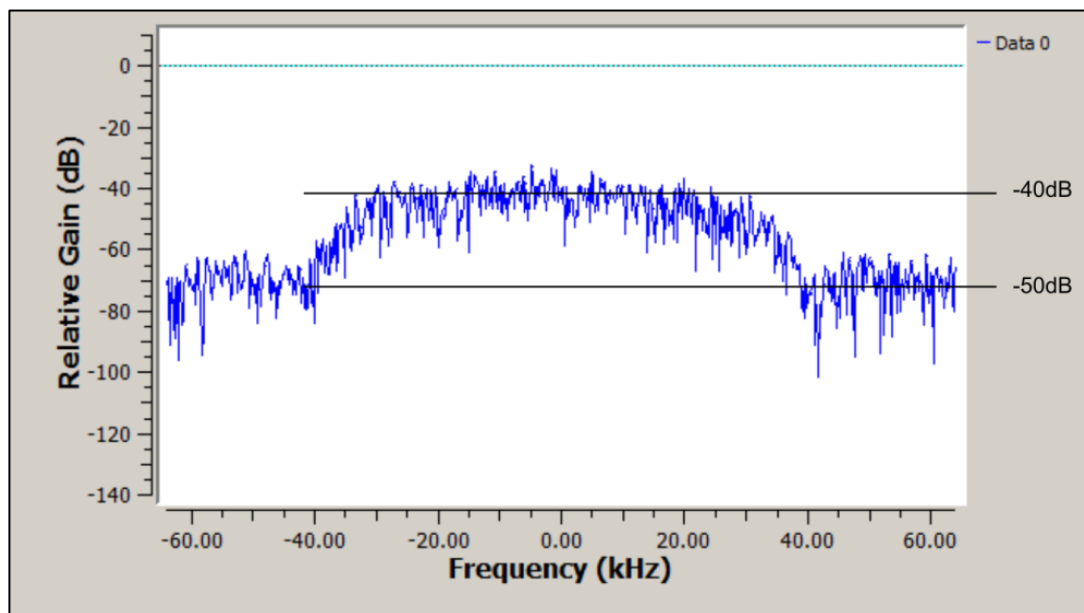

Figure 4.3. Signal power measurements.

Further, both transmitter and receiver were placed in multiple locations in experimental environment. The environment was designed in 3 m x 6 m that consist of two rooms. These two rooms were connected by a door. Four scenarios were design to carry out this experiment. The transmitter placed in fixed position. Receiver placed in four different positions which were position I, II, III and IV as illustrated in the Figure 4.4.

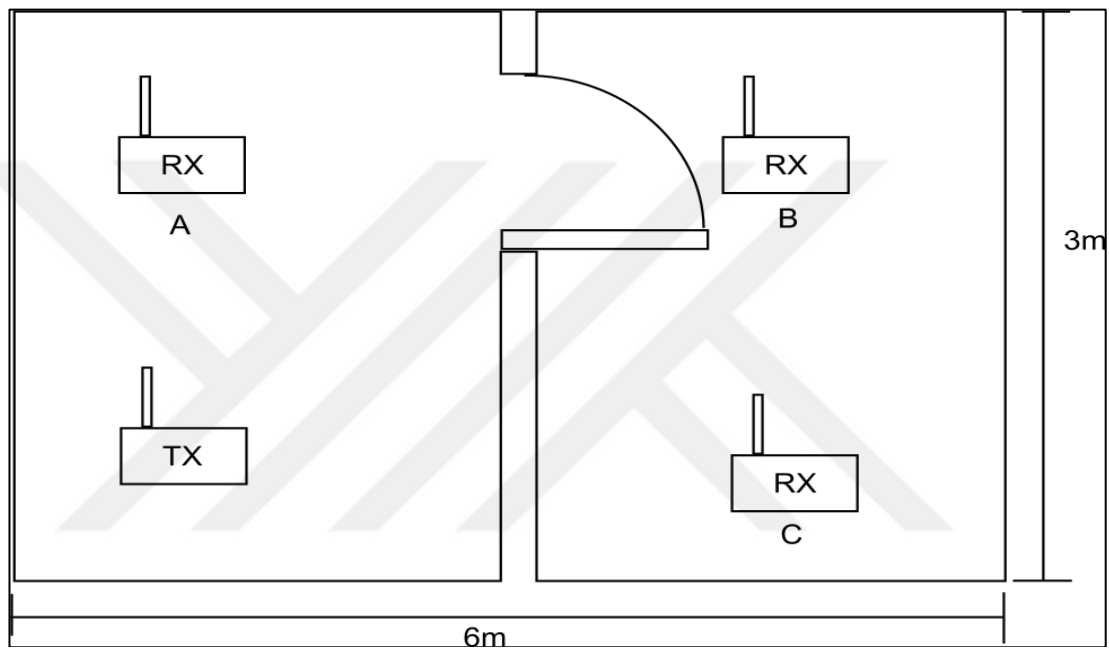

Figure 4.4. Experiment environment.

Table 4.1. Experimental results.

Scenario	Point	Distance	Power	Result
I	A	2m	12 dB	Music ON
II	B	4m	10 dB	Music ON
III	C *	3,7m	9 dB	Music ON
IV	C **	3,7 m	5dB	Music ON

\* Door opened.

\*\* Door closed.

Table 4.1 describes that there are different power in each scenario. The first scenario carried out by placing the receiver in point A with the distance about 2 m between the transmitter and receiver as shown in the figure. This scenario produced power of 12 dB and the music was able to be received and played in the receiver device. The second scenario taken place by placing the receiver in point B in separated room with the transmitter with 4 m distance from the transmitter. This scenario produced power 10dB. The music was on in the receiver device. The third and fourth scenario was conducted by placing the receiver and transmitter in the separated room with the distance about 3.7 m. The difference was that the third scenario conducted without closing the door, but the fourth scenario conducted with the closed door. The results show that the third scenario produced 9 dB while fourth scenario was 5dB. The music was able to received and played in both scenarios.

## **CHAPTER 5**

### **CONCLUSION AND RECOMMENDATION**

#### **5.1. CONCLUSION**

This project aims to implement Software Defined Radio (SDR) using HackRF One as a mid-range open source hardware to transmit and receive GFSK signal and evaluate receiving performance. Various scenario measurements were carried out to assess the performance of signal reception quality. GNU radio proposed as a software platform. All signal processing blocks were written using the C++ programming language, while the python was used to link among blocks. The results show that the digital data was successfully transmitted and received by proposed method. It produced different power in each scenario which was 12dB in the scenario I, 10dB in scenario II, 9 dB in scenario III and 5 dB in scenario IV.

#### **5.2. RECOMMENDATIONS**

The Gaussian Frequency Shift Keying (GFSK) filters the data pulses with the use of a Gaussian filter in order to get smoother transitions. The filter can reduce the sideband power and the interference with adjacent channels with increasing the inter-symbol interference. Gaussian filtering is a typical manner to decrease the spectral width so it is known as "pulse shaping" in this application.

## REFERENCES

1. Mannan, P.M., "Framework for the Design and Implementation of Software Defined Radio Based Wireless Communication System", *The University of Akron*, (2009).
2. Rong, L., "All Digital Polar Transmitter Design for Software Defined Radio: Architecture and Low Power Circuit Implementation", *KTH Royal Institute of Technology* , (2012).
3. Mitra, A., "Lecture notes on mobile communication", A Curriculum Development Cell project Under QIP, *IIT Guwahati* , (2009).
4. Hudson, W.J. and Luecke, J., "Basic Communications Electronics Radio Shark", *Master Publishing Inc.*, Lincolnwood, Illinois, (1999).
5. Beasley, J.S. and Miller, G.M., "Modern Electronic Communication, 8th Edition", *Pearson Inc.* , (2005).
6. Tomasi, W., "Advanced Electronic Communication System", 2nd ed., *Prentice Hall inc.* , (1992).
7. Batho, E.S., "Electronic design principles", 1st Edition ed., *Prentice Hall Inc.* New York, (1992).
8. Fagbohun, O.O., "Development of a low-cost frequency shift keying signal Transmitter for digital signal processing", *IOSR Journal of Electronics and Communication Engineering (IOSR-JECE)* ,p. 2278-2834, (2014).
9. Omura, A.V.J., "Principles of digital communication and coding", Third Edition, *Prentice Hall International inc.* ,(2004)
10. Singh, A. and Chhabra, A. K., "Fundamental Of Digital Electronics And Microprocessors", *S. Chand Publisher* ,(2005).
11. Berube, R.H., "Learning Electronics communications through experimentation using electronic workbench multisim", *Prentice Hall inc.* ,(2002).
12. Bob, W., "FSK: signals and demodulation", *Watkins-Johnson Company Tech-notes 7.5* (1980).
13. Marriwala, N., Sahu, O. and Vohra, A., "Design of a hybrid reconfigurable Software Defined Radio transceiver based on frequency shift keying using multiple encoding schemes", *Egyptian Informatics Journal*, 17(1): p. 89-98 (2016).

14. Internet: Feng, Z., "A software defined radio implementation using MATLAB", <https://www.theseus.fi/handle/10024/60089> ,(2013).
15. Quadri, F. and Tete, A.D., "FPGA implementation of digital modulation techniques. in Communications and Signal Processing (ICCSP)", **2013 International Conference on IEEE**, (2013).
16. Yeh, C.-A. and Lai, Y.-S., "Digital pulsewidth modulation technique for a synchronous buck DC/DC converter to reduce switching frequency", **IEEE Transactions on industrial electronics**, 59 (1): p. 550-561, (2012).
17. Gandhiraj, R. and Soman, K., "Analog and digital modulation toolkit for software defined radio", **Procedia Engineering**, 30: p. 1155-1162, (2012).
18. Nguyen, T.D., et al., "A direct digital technique implementation of general discontinuous pulse width modulation strategy", **IEEE Transactions on Industrial Electronics**, 58(9): p. 4445-4454 ,(2011).
19. Chong, K., et al., "Evaluation of the effect of step size on delta modulation for photoplethysmogram compression", **Procedia Technology**, 11: p. 815-822 , (2013).
20. Grayver, E., "Implementing software defined radio", **Springer Science & Business Media** ,(2012).
21. Purani, A.M., "An evaluation of low cost FPGA-based software defined radios for education and research", **The University of Tennessee at Chattanooga** , (2010).
22. Olivieri, S.J., et al. "Modular FPGA-based software defined radio for CubeSats. in Communications (ICC)", **2012 IEEE International Conference** , (2012).
23. Roupheal, T.J., "RF and digital signal processing for software-defined radio: a multi-standard multi-mode approach", **Newnes** , (2009).
24. Watson, B., "FSK: signals and demodulation", **Watkins-Johnson Company Tech-notes**, 7(5), (1980).
25. Langton, C., "Tutorial 12 Coding and decoding with Convolutional Codes", **Complex2Real. com Complex Communications Technology Made Easy** , (1999).
26. Haykin, S., "Communication Systems", 4th Edition, **John Wiley & Son Inc.** , (2001).
27. Virk, K.M., "Design of an integrated GFSK demodulator for a Bluetooth receiver", **Project report, Informatics & Mathematical Modeling, Technical University of Denmark**, Lyngby, Denmark, (2001).

28. Machado-Fernández, J.R., "Software Defined Radio: Basic Principles and Applications", *Facultad de Ingeniería*, 24(38): p. 79-96, (2015).
29. VonEhr, K., Neuson, W., and Dunne, B.E., "Software Defined Radio: Choosing the Right System for Your Communications Course", *ASSE's 123<sup>rd</sup> Annual Conference Exposition*, New Orleans, LA, (2016).
30. Internet: Gnuradio , "Gnuradio", <http://gnuradio.org/>. (2017).
31. Internet: Tutorialspoint, "Overview, T.C.-", [https://www.tutorialspoint.com/cplusplus/cpp\\_overview.htm](https://www.tutorialspoint.com/cplusplus/cpp_overview.htm) (2017).
32. Internet: Sitesbay, "C++, S.F.o.", <http://www.sitesbay.com/cpp/features-of-cpp> (2017).
33. Internet: Python, "Python", <http://www.python.org> (2017).
34. Internet: Swig, "Swig, W.t.S.", <http://www.swig.org/> (2017).

## **RESUME**

Abdulgader Elamin ELSAGHIER was born in Misurata, Libya in 1978. He studied first and elementary education in this city. He graduated Secondary School of Scientific in 1996. He hold bachelor degree in Communication from Engineering Faculty of Al-Margib University, Al-Khoms, Libya in 2001. His work experiences started by joining Secondary Institute of Polytechnics in Misurata (Libya) as a Trainer from 2002 to 2003. He continued his career as Trainer at High Institute of Polytechnics in the same city from 2004 to 2014 and he was also as the Head of Schedule Preparation Team. He promoted as the Registration Director of Study and Examination Office in same institution from 2012 to 2014. Further he continued his master education at Karabuk University, Turkey.

### **CONTACT INFORMATION**

Çankaya/Ankara. Sokullu Mehmet Paşa, Nimet Sk. No: 35/8

Phone (0090) 5385-149746

E-mail: [abdulgadir\\_amin@yahoo.com](mailto:abdulgadir_amin@yahoo.com)