

**OPTIMIZATION OF SURFACE ROUGHNESS ON A
MILLING PROCESS USING STOCHASTIC
METHODS**

**A Thesis Submitted to
the Graduate School of Engineering and Sciences of
İzmir Institute of Technology
in Partial Fulfillment of the Requirements for the Degree of
MASTER OF SCIENCE
in Mechanical Engineering**

**by
Özcan DİNÇ**

July 2019

İZMİR

We approve the thesis of **Özcan DİNÇ**

Examining Committee Members:

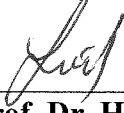

Assoc. Prof. Dr. H. Seçil ARTEM

Department of Mechanical Engineering, İzmir Institute of Technology



Assist. Prof. Dr. Ebubekir ATAN

Department of Mechanical Engineering, İzmir Katip Çelebi University

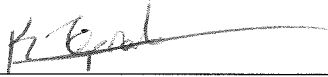

Assist. Prof. Dr. Kasım TOPRAK

Department of Mechanical Engineering, İzmir Institute of Technology

17 July 2019



Assoc. Prof. Dr. H. Seçil ARTEM

Supervisor, Department of Mechanical Engineering, İzmir Institute of Technology



Prof. Dr. Sedat AKKURT

Head of the Department of Mechanical Engineering

Prof. Dr. Aysun SOFUOĞLU

Dean of the Graduate School of Engineering and Science

ACKNOWLEDGMENTS

I would like to express my deeply and sincerely thanks to the precious scientist and my advisor Assoc. Prof. Dr. H. Seil ARTEM. I could not imagine finishing this study without her help and continuous support. She gave me constructive comments and warm encouragement.

I would like to thank Assist Prof. Dr. Levent AYDIN, İzmir Kâtip elebi University for sincere helps. Without his guidance and persistent help this thesis would not have been possible. I would like to thank Mr. Melih SAVRAN for fast feedbacks and comments during the whole thesis period. I am grateful to Atıl KARAKAŐLI, machining department manager and Ali KARA, Ph.D. R&D engineer in CMS Group and also to CMS Group, for their endless support and for encouraging me during my work through the whole period of my thesis.

Finally, I would like also to thank to my parents and express my gratitude to my mother and father for their endless support, motivation and understanding at every stage of my life.

ABSTRACT

OPTIMIZATION OF SURFACE ROUGHNESS ON A MILLING PROCESS USING STOCHASTIC METHODS

Nowadays, milling process is one of the most widely used metal processing methods in many fields from space and aircraft to automotive industry. The surface roughness values of the workpiece in milling process vary depending on the thermal, chemical and abrasive loads that occur during cutting. Spindle speed, depth of cut and feed rate are the cutting parameters affecting the surface roughness. Hence, these parameters at the time of machining constitute an important issue. Accordingly, in this thesis optimization of surface roughness has been performed using the stochastic search methods. First, using experimental data obtained in the milling process, it was aimed to establish a regression model to determine average surface roughness equation as an objective function. The cutting parameters and average surface roughness value were considered as input and output in regression analysis, respectively. In this study, seven different mathematical models have been established and examined to carry out regression analysis. The reliability and stability of the mathematical models were investigated. The most appropriate mathematical model has been constructed and then used as an objective function for optimization. Nelder-Mead, Random-Search, Simulated Annealing, and Differential Evolution were the stochastic search algorithms to perform the optimization in the present study. In conclusion, it was found that the minimum average surface roughness value depends on spindle speed, depth of cut and feed parameters.

ÖZET

STOKASTİK YÖNTEMLER KULLANARAK FREZELEME İŞLEMİNDE YÜZEY PÜRÜZLÜLÜĞÜ OPTİMİZASYONU

Günümüzde metal işleme yöntemlerinden biri olan frezeleme işlemi uzay ve uçak sanayinden otomotiv sanayisine kadar bir çok alanda yaygın olarak kullanılmaktadır. İş parçasının yüzey pürüzlülük değerleri kesme anında oluşan termal, kimyasal ve aşındırıcı yüklere bağlı olarak değişmektedir. İş mili hızı, kesme derinliği ve ilerleme, yüzey pürüzlülüğünü etkileyen kesme parametreleridir. Bu nedenle, işleme anındaki bu parametreler önemli bir konudur. Buna göre, bu tezde yüzey pürüzlülüğü optimizasyonu stokastik arama yöntemleri kullanılarak yapılmıştır. İlk olarak, frezeleme işleminde elde edilen deneysel verileri kullanarak, ortalama yüzey pürüzlülüğü denklemini amaç fonksiyonu olarak belirlemek için bir regresyon modelin oluşturulması amaçlanmıştır. Kesme parametreleri ve ortalama yüzey pürüzlülüğü değeri, optimizasyon analizinde sırasıyla girdi ve çıktı olarak kabul edildi. Bu çalışmada, regresyon analizi yapmak için yedi farklı matematiksel model kurulmuş ve incelenmiştir. Matematiksel modellerin güvenilirliği ve kararlılığı araştırılmıştır. En uygun matematiksel model inşa edilmiş ve sonra optimizasyon için amaç fonksiyonu olarak kullanılmıştır. Nelder-Mead, Random-Search, Simulated Annealing ve Differential Evolution bu çalışmada optimizasyonu gerçekleştirmek için kullanılan stokastik arama algoritmalarıdır. Sonuç olarak, minimum ortalama yüzey pürüzlülük değerinin iş mili hızına, kesme derinliğine ve ilerleme parametrelerine bağlı olduğu bulunmuştur.

TABLE OF CONTENTS

LIST OF FIGURES.....	viii
LIST OF TABLES	ix
CHAPTER 1. INTRODUCTION	1
1.1. Literature Survey.....	1
1.2. Objectives.....	5
CHAPTER 2. MILLING PROCESS	6
2.1. Milling.....	6
2.2. Tool Wear.....	8
2.3. Tool Wear Measurement.....	10
CHAPTER 3. REGRESSION ANALYSIS	13
3.1. Regression Models	13
3.2. Purpose of Regression Analysis.....	14
3.3. Non-Linear Regression Analysis	15
CHAPTER 4. MATHEMATICAL MODEL.....	17
4.1. Mathematical Models.....	17
4.2. Coefficient of Determination	23
4.3. Adjusted Coefficient of Determination	25
4.4. Training and Testing	26
4.5. Stability Analysis of Mathematical Models.....	28
CHAPTER 5. OPTIMIZATION.....	37
5.1 Single-Objective Optimization.....	38
5.2 Multi-Objective Optimization.....	38
5.3 Stochastic Optimization Algorithms	38
5.3.1 Nelder-Mead Method	39

5.3.2 Random Search Method	39
5.3.3 Simulated Annealing Method.....	39
5.3.4 Differential Evolution Method	40
CHAPTER 6. RESULTS AND DISCUSSION	43
6.1 Problem Statement	43
6.2 Evaluation of Regression and Optimization Results	44
CHAPTER 7. CONCLUSION.....	50
REFERENCES.....	51



LIST OF FIGURES

<u>Figure</u>	<u>Page</u>
Figure 2.1 Milling types (a) face milling (b) shoulder milling.....	7
Figure 2.2 Milling types (a) peripheral (or flank) milling (b) ball-end milling.....	7
Figure 2.3 Groove or slot milling operation with different types of end mill	8
Figure 2.4 Cutting speeds in milling for different materials.....	9
Figure 2.5 Comparison between the workpiece surfaces (a)new cutting tool and (b)worn cutting tool	9
Figure 2.6 Central wear and flank wear at the cutting edges are monitored by SEM with original magnification 100 times.....	10
Figure 2.7 The probe tip scans the surface profile with selected probe speed	11
Figure 2.8 Surface roughness measurement instrument Form Talysurf120.....	11
Figure 4.1 Schematic illustration of a milling process	18
Figure 4.2 Stability analysis for Model 1	29
Figure 4.3 Stability analysis for Model 2	30
Figure 4.4 Stability analysis for Model 3	31
Figure 4.5 Stability analysis for Model 4	32
Figure 4.6 Stability analysis for Model 5	33
Figure 4.7 Stability analysis for Model 6	34
Figure 4.8 Stability analysis for Model 7	35
Figure 5.1 The flowchart of Nelder-Mead optimization algorithm	40
Figure 5.2 The flowchart of Random Search optimization algorithm.....	41
Figure 5.3 The flowchart of Simulated Annealing optimization algorithm	42
Figure 5.4 The flowchart of Differential Evolution optimization algorithm.....	42
Figure 6.1 The effect of spindle speed and feed-rate for 3 mm depth of cut	45
Figure 6.2 The effect of depth of cut and feed-rate for 2000 rev/min spindle speed	45
Figure 6.3 The effect of depth of cut and spindle speed for 50 mm/min feed-rate	45
Figure 6.4 The effect of 3 different inputs on average surface roughness	46

LIST OF TABLES

<u>Table</u>	<u>Page</u>
Table 4.1. Input and output parameters	17
Table 4.2. Experimental data used to carry out regression analysis	19
Table 4.3. Different mathematical models.....	20
Table 4.4. Formulations for different mathematical models	21
Table 4.5. Experimental(R_a^*) and Predicted (R_a) values for models 1 to 7.....	22
Table 4.6. Average prediction error of the models	22
Table 4.7. Prediction errors (%) of the models	23
Table 4.8. R^2 values for mathematical models	24
Table 4.9. R_{adj}^2 values for 7 models	25
Table 4.10. Training data set	26
Table 4.11. $R_{training}^2$ and $R_{training_{adj}}^2$ values for 7 models	27
Table 4.12. $R_{testing}^2$ values for the selected models	28
Table 4.13. Stability analysis for Model 1.....	29
Table 4.14. Stability analysis for Model 2.....	30
Table 4.15. Stability analysis for Model 3.....	31
Table 4.16. Stability analysis for Model 4.....	32
Table 4.17. Stability analysis for Model 5.....	33
Table 4.18. Stability analysis for Model 6.....	34
Table 4.19. Stability analysis for Model 7.....	35
Table 6.1. Comparison of experimental and predicted results of Model 6.....	47
Table 6.2. S/N ratio effects as constraint	47

CHAPTER 1

INTRODUCTION

1.1 Literature Survey

Requirement of the good quality work pieces for industry, a wide variety of machining techniques has been developed since the accuracy and precision desired by the customer, have been increased related with the working condition of the work pieces. Over the last decades, demand of the metal-machining increased steadily [1].

Copying the work pieces has been based on two different methods in 1960s. The work pieces have been machined by turning centers and machining centers. Several tools have been investigated to perform the special processing operations and thus the tool industry has grown simultaneously. Due to the high cost investment budget, the machines have been heavily run in order to increase productivity. As a requirement of this, the need for high-speed centers has been increased [1].

In automotive and aerospace industry, the parts have generally hole and mounting profile for installation. End milling process has wide range use for complex profiles and geometry. The tool material is generally chosen from high-speed steel, solid carbide, or with coated or uncoated carbide inserts. Quality of the work piece surface depends on material thermal properties, machining parameters, cutting fluids and environmental conditions [2].

The Taguchi method has been studied for finding the optimal cutting parameters for surface roughness in turning operation. Taguchi's robust orthogonal array has been used to calculate the smaller-the better signal-to-noise ratio which to obtain minimum surface roughness for the material AISI 1030 carbon steel [3]. A full quadratic polynomial has been used for modelling the process which is used for optimization of cutting parameters of an aluminum mold in order to get good bonding of a PDMS. In this study, response surface method is performed to achieve the minimum value of surface roughness

by finding the optimal cutting parameters [4]. Eşme and Serin have investigated the cutting parameters to find the optimum values such as depth of cut, feed rate and cutting speed. ANOVA results indicate that which parameter has more effect of the tangential, radial and axial forces [5].

The several coating and tool types and specific cutting parameter effects were investigated and optimized to get the minimum average roughness of the milling surfaces. Due to F and P-test results, a general linear regression model has been used to predict the process with the determination coefficient of 0.90 [6]. Neural networks have been investigated to predict CBN (cubic boron nitride) tool wear and average surface roughness in turning process. Workpiece hardness, feed rate, cutting speed and tool edge geometry were studied to decrease the average surface roughness by non-linear mapping system neural networks. A comparison between the regression and neural network indicate that the neural network has more fitted in flank wear and surface roughness than exponential regression model [7].

Genetic algorithms have been studied for machining process time, tool wear and process energy. Within three objective functions and machining constraints were investigated based on posteriori multi objective resource consumption. In order to model the process design of experiment regression equation in computer program MATLAB was used. For genetic algorithm implementation based on non-dominated algorithm MATLAB was applied [8].

The hybrid artificial bee colony algorithm was investigated for feed rate, cutting speed, and depth of cut in rough and finish turning. This study includes a comparison of results with different optimization techniques such as hybrid robust differential evolution, differential evolution receptor editing, hybrid robust genetic algorithm, scatter search, float encoding genetic algorithm and simulated annealing and Hooke-Jeeves Pattern Search [9]. One of the multi-objective optimization approaches that is called neural network has been applied to maximize the life of the tool which is made from HSS. Neural networks is useful for fault-tolerant structure. To compute the data and the modelling the phenomena is simple. Radial basis neural network has been chosen due to the time to process the training and testing data [10]. Fuzzy synthetic evaluation and Back Propagation (BP) Neural Network with Bayesian regulation optimization method have been used together for aluminum to obtain optimum milling parameters. In some

complex decision-making problems, numerical methods are not sufficient due to the number of inputs and complexity. Fuzzy synthetic evaluation method can compensate the effect of different indexes at the same time. Bayesian regularization is used for increase the generalization of neural network with BP Neural Network. In the case of problems with too many outputs, the effect can be better observed [11].

Especially in recent studies on fine hard ceramic coatings, experimental design methods have been used to reduce the number of experiments. Other studies have shown that cutting force is a criterion that can be used in evaluation. Thus, both the use of the experimental design and the evaluation through the shear forces, the time and costs required to achieve the results and to achieve the optimization have been greatly reduced. There are some points that should not be forgotten when evaluating these values calculated with Taguchi Experiment Design. The most important of these is that the interactions between the experimental design and the factors (such as the interaction between the cutting speed and the feed rate) are ignored and the factors cannot be selected for an optimum value other than the levels determined at the planning stage. The design of such limitations should be considered at the forefront of the studies to be used [12].

To minimize the mean roughness depth and average roughness value on the surface of hardened AISI 4140 with the hardness of 51 RC, statistical methods have been used. Signal-to-noise ratio and variance analyses which is called ANOVA are two basic methods for determine the optimum cutting speed, feed rate and depth of cut. The smaller the better approach was applied for surface roughness value to gain maximum signal-to-noise ratio. The mutual effects of cutting speed with depth-of-cut and feed-rate have a great importance. The minimum feed-rate, depth of cut and cutting speed are the optimum values subsequently [13]. Another study gives an insight the optimum parameters change for different machining conditions and materials. Cutting speed and depth of cut are major effects for turning of mild steel with hardness 130 BHN with coated carbide tool. Feed rate has the least effect [14].

Hybrid optimization techniques are used to increase the search ability and to make the results more accurate. This new approach is based on the principle of simultaneously using stochastic optimization techniques such as differential evolution to bring solution to machining problems. The optimum machining parameters have been selected to minimize a machining cost by two stage Differential Evolution optimization method.

With this method, better results have been obtained compared to single use of Differential Evolution. Significant results have been obtained that hybrid robust differential evolution can be used to optimize machining parameters [15]. Genetic algorithm and simulated annealing have been studied for multi-pass milling as a hybrid approach to minimize the production time which is the total time to produce a completed part from preparation to machining. For all four time periods mathematical equations were investigated. Five different constraints have been chosen for the machine and apparatus limits. Genetic simulated annealing algorithm have better results than genetic algorithm and geometric programming in milling operation for different objective functions [16].

The Taguchi method is also used to optimize multiple parameters at the same time. The end milling process has been investigated L27 orthogonal array to obtain the minimum surface roughness, temperature and cutting force. Magnesium metal matrix composite by using carbide tool in end milling process have been studied. Regression analysis is used to build the mathematical structure. Optimization algorithms which are Grey Relational Analysis (GRA) and Techniques for Order Preferences by Similarity to Ideal Solution (TOPSIS) have been applied to multiple objective problem. These two techniques have almost same solutions [17]. Response surface methodology and Genetic Algorithm have been used to find the most suitable machining parameters for the Al 7075-T6 material in shoulder milling. The second order equation which represents the model have been studied and have been tested by analysis of variance. Genetic Algorithms have been selected to optimize the machining parameters to obtain lower cutting force. Cutting forces are simply measured with tool dynamometers. The computer program MATLAB have been used to solve the genetic algorithm by algorithm solver [18].

Optimization methods are commonly used in several engineering problems to create or design complex systems to increase the efficiency of the system in the field of aerospace, automotive, marine and chemical industries. Some of their applications are cost-friendly machining processes, high efficiency energy consumptions processes or lightweight product design. Even though most engineering design problems can be solved using non-linear programming techniques stochastic programming techniques such as Differential Evaluation, Nelder-Mead, Random Search, Simulated Annealing which are most suitable [19].

1.2 Objectives

In this thesis, analysis and optimization of end-milling process machining parameters spindle speed (n), depth of cut (a), and feed (f) for minimum surface roughness have been performed by four different stochastic algorithms. Differential Evolution (DE), Simulated Annealing (SA), Random Search (RS), and Nelder Mead optimization algorithms have been studied.

The objectives of this study can be considered as follows;

- Defining the phenomenon and finding the coefficient of determination by mathematical model in the best way
- The possibility of experimental parameters selected and commenting behavior of machine for different machine parameters
- Determination of objective function
- Investigating optimum average surface roughness value for three different machining parameters
- Comparison of four different stochastic optimization algorithms

It should be noted that defining the best mathematical model is not simple for any machining parameters as well as another machining process turning, drilling etc. Because, different disturbances dominate the system at different levels. Therefore, the mathematical model might be built according to other parameters such as material of cutting tool, cooling flowrate, workpiece material etc. However, if some of input values are selected to decrease the average roughness value, it would be more accurate to define the optimization problem.

In this thesis, the experimental data taken from the study of... is used for analysis and optimization purposes. This data set have the cutting parameters, spindle speed (n), depth of cut (a), feed rate(f) and the corresponding average surface roughness values. First, the mathematical model predicting the data was investigated for average surface roughness by performing Regression analysis. The accuracy of the model has also been verified by regression test methods. Then, cutting parameters were optimized for minimum surface roughness utilizing optimization methods.

CHAPTER 2

MILLING PROCESS

2.1. Milling

Machining is any of various processes in which a piece of raw material is cut into a desired final shape and size by a controlled material-removal process. There are so many types of machining such as turning, milling, drilling etc.

Milling process has different technique from turning operation. Tools have multiple cutting profiles. These cutting edges move along the tool path in order to obtain flat or required surface profiles. The feed direction is perpendicular to the rotation of the axis of the tool [20].

The cutting tool is made of harder material than the workpiece material. Relative motion is necessary to machine the workpiece. The first motion is achieved with a specific speed as called cutting speed (v). Besides the cutting speed, the tool also moves with the terms of feed (f). The remaining parameter is the distance that the tool moves into the workpiece called depth of cut (a). These three terms are completely known as cutting conditions. The machine tool is a to hold the work piece, position the tool relative to the work, and provide power for the machining process at the speed, feed, and depth that have been set [20].

Early 1960s milling had been used for single purpose as obtaining flat surface. However, after machine center technology with desired accuracy and precision any desired tool path geometry is processed. Nowadays there are four types of milling operations such as face milling, shoulder milling, peripheral milling (or known as flank milling), and ball end milling shown in Figure 2.1 and Figure 2.2 [21].

In order to achieve the desired geometry, the number of types of milling operations have increased for more specific machining such as profile milling, square shoulder

milling, slot milling. In slot milling tool generates a tool path within slot by various types of end mill as shown in Figure 2.3 [22].

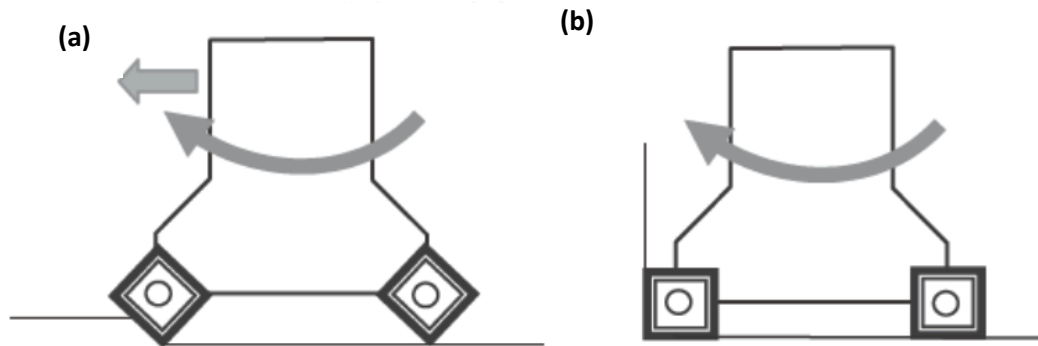

Figure 2.1 Milling types (a) face milling (b) shoulder milling (Source: [21])

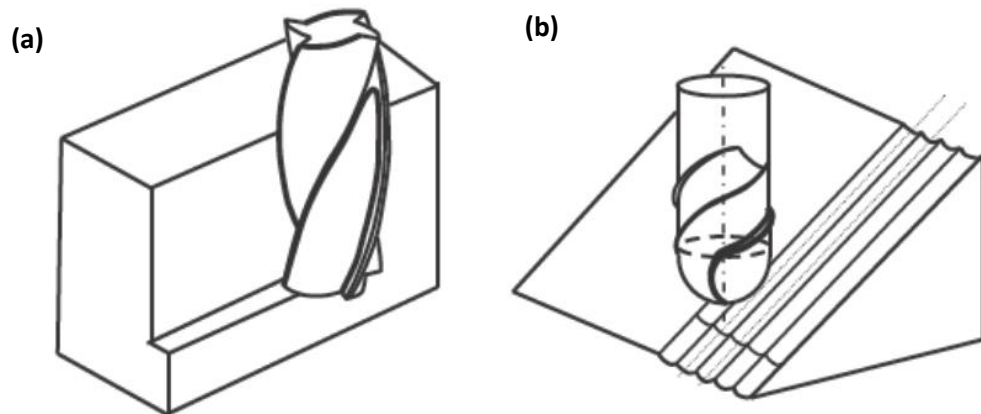

Figure 2.2 Milling types (a) peripheral (or flank) milling (b) ball-end milling (Source: [21])

With the increasing of machining technologies and processing speeds, the wear of the tool is increasing. Machine tools need to be renewed due to the reduced workpiece surface quality with the wear of the tools. This leads to increased tool costs. On the other hand, due to the fact that the surface roughness values are desired, the effect of the tool wear on the surface quality is increasing.

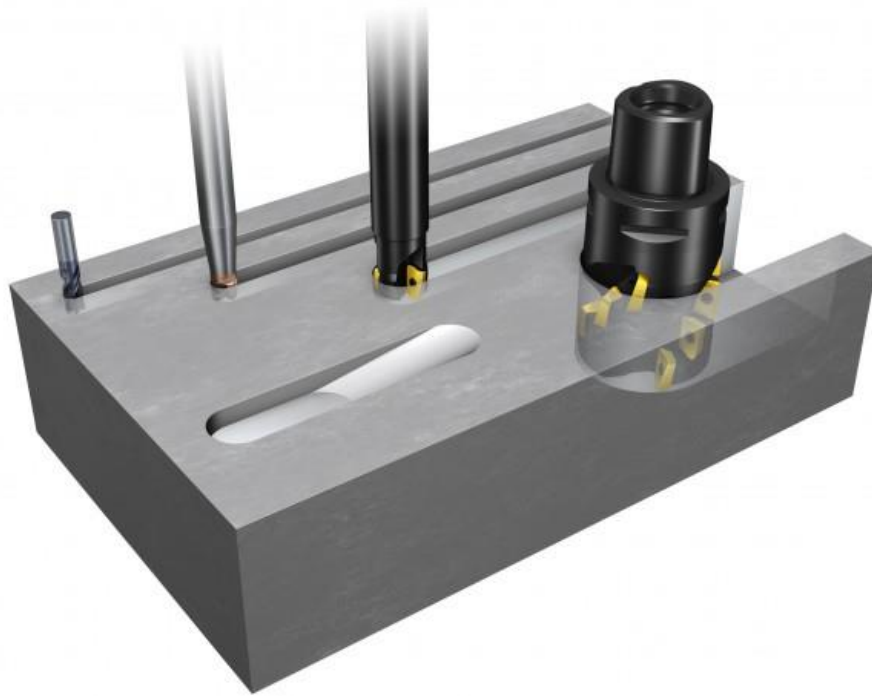

Figure 2.3 Groove or slot milling operation with different types of end mill
(Source: [22]).

2.2 Tool Wear

A material removal process provides dimensional accuracy and surface quality of the material. The degree of surface quality is mostly related to the surface profile of the cutting tool. Tools wear over time because of the mechanical, thermal, chemical and abrasive loads and thus tool change operations makes an unproductive production due to cutting tool cost and set-up time which is unavailable period to produce. These instabilities create different work areas for tool users and machine manufacturers.

The tool wear is based on friction of metal cutting which is affected by the cutting power, machining quality, tool life and machining cost. As tool wear reaches high, the surface quality decreases and dimension error starts appearing as shown in Figure 2.5.

Determining the life of the cutting tool is beyond the measurements of flank or crater wear because the unknown inputs also play a role for tool wear in small and even large part. With high-speed cutting operations cutting loads on cutting tools increase in proportion to cutting speed. Figure 2.4 indicates that cutting speed ranges according to different materials [23].

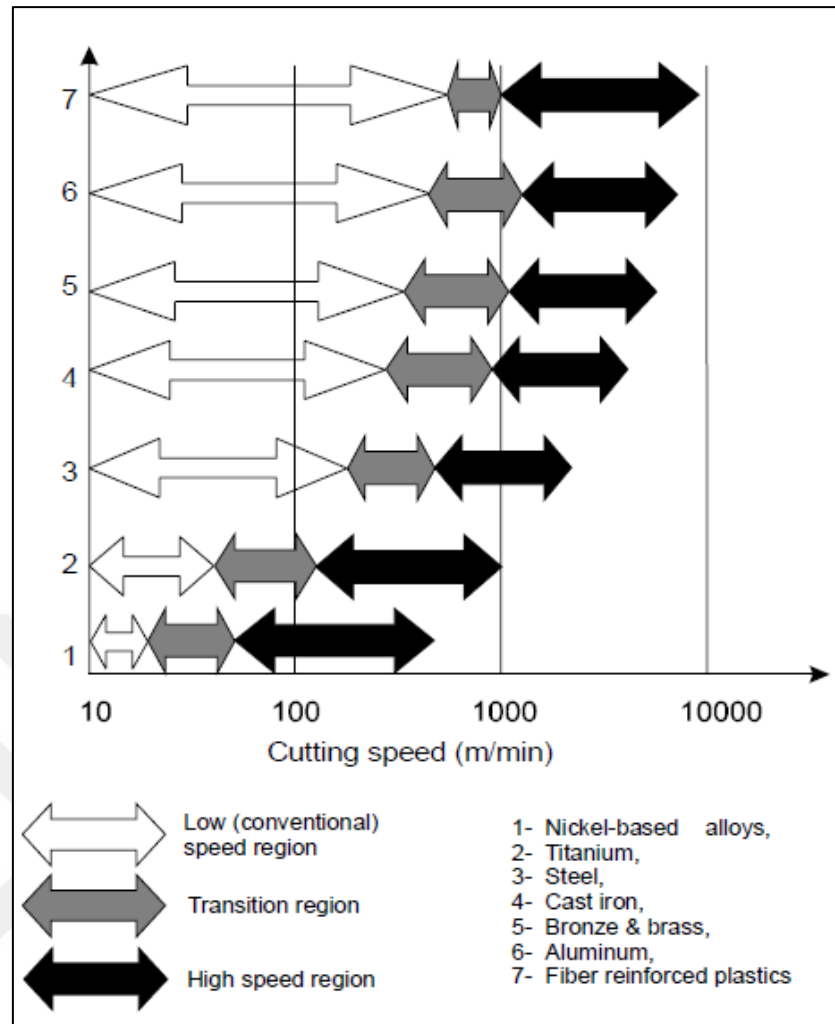

Figure 2.4 Cutting speeds in milling for different materials (Source: [23])

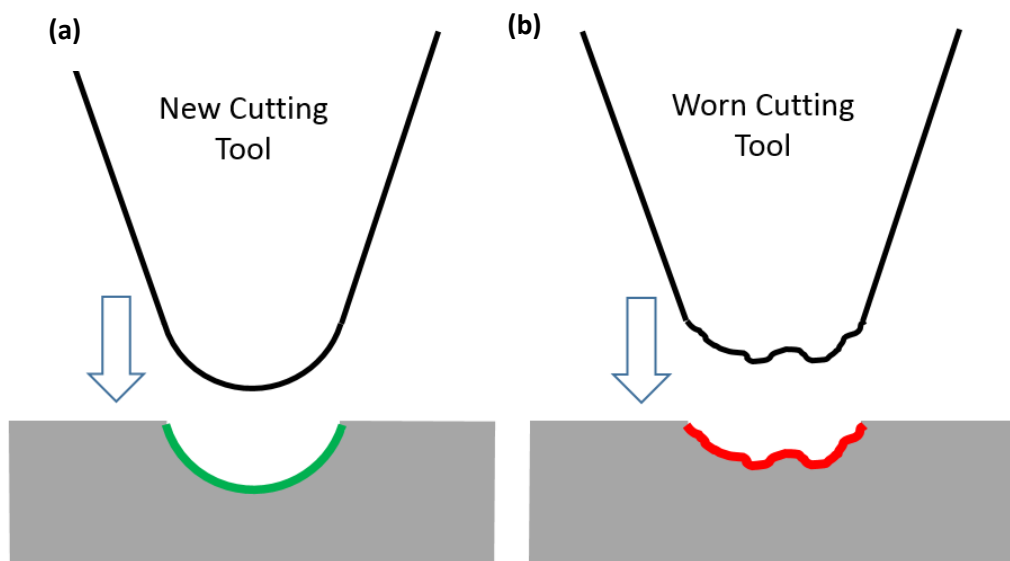

Figure 2.5 Comparison between the workpiece surfaces (a) new cutting tool and (b) worn cutting tool.

In end-mill cutters occurs mainly two different types of wear. One of them is flank wear where occurs at the cutting edges of tool. Another type is central wear where occurs at the center of the tool. Figure 2.6 shows the wear mechanisms where is monitored by SEM and types of the wear. Comparing with the ordinary flank wear of the single point turning tool or twist drill, these types of wear are completely different [24].

Increased tool life reduces these repetitive processes at this stage. Therefore, choosing the optimal cutting parameters is a great importance for a milling process and also turning processes at the point of cost and quality.

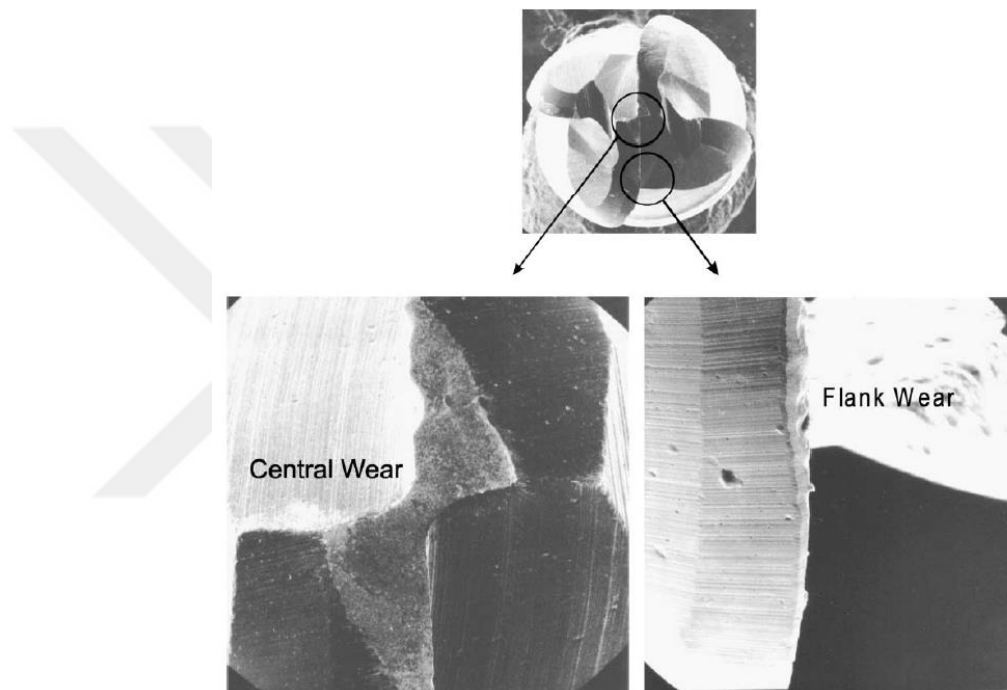

Figure 2.6 Central wear and flank wear at the cutting edges are monitored by SEM with original magnification 100 times (Source: [24])

2.3 Tool Wear Measurement

Tool wear is measured with two fundamental techniques. First technique is to measure the tool geometry to calculate the wear ratio. Second technique is to measure the workpiece surface profile to define the traces which have been formed by the tool.

Generally, the finish surface profile scanning is preferred to avoid tool replacement and set-up time. A probe of measurement device touches the finish surface and measure the height of the surface and evaluate the differences. The measurement

device work on the one direction depending on the selected measuring range and speed as seen in Figure 2.7 [25].

In this study FormTalysurf120 was used to measure the surface profile as seen in Figure 2.8 [26]. The measurement parameters have been set to sampling length of 5mm and the probe speed of 0.5 mm/s. From different three regions have been measured and the average roughness value has been calculated for avoiding the measurement errors.

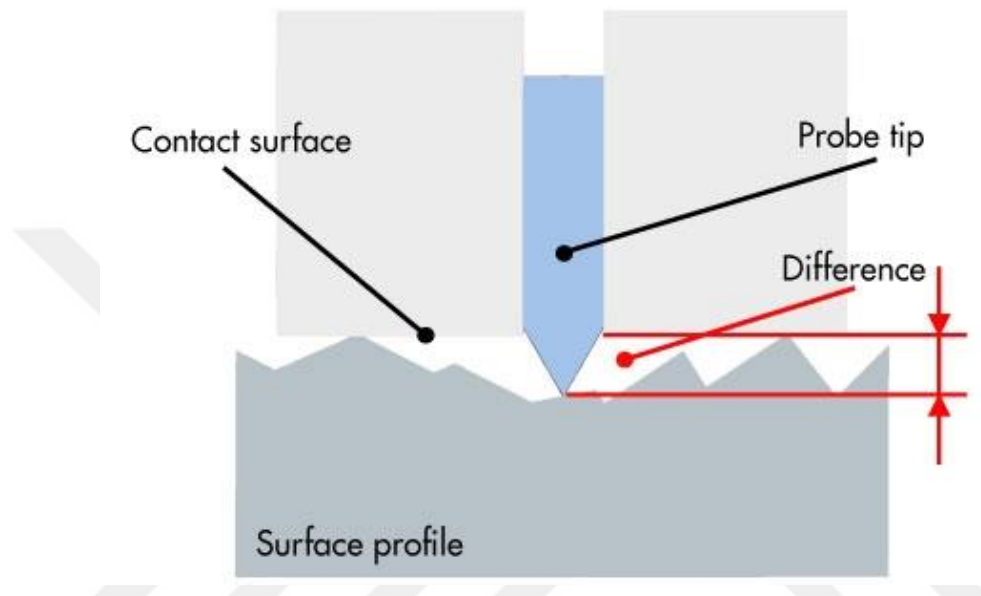

Figure 2.7 The probe tip scans the surface profile with selected probe speed
(Source: [25])



Figure 2.8 Surface roughness measurement instrument Form Talysurf120 (Source: [26])

Even though measurements are made by touching the surface, there are new approaches that is based on to calculate cutting forces from tool end by a dynamometer or machine energy consumption indirectly. The philosophy here is to establish a mathematical relation with the cutting force or energy consumption that occurs during the machining and the cutting tool wear [27,28].

In this study, it is aimed to establish mathematical model by using regression analysis to obtain optimum average surface roughness value. For this reason, the accuracy and the verification of the mathematical model and how well the inputs define the problem are so important and critical.



CHAPTER 3

REGRESSION ANALYSIS

Regression analysis is utilized to simulate the relationship between the input and output of the engineering systems as a mathematical function. Statistical measurements are increased to find the strength of relationship between dependent and independent variables. This mathematical function is named as regression equation.

Regression analysis offers a mathematical equation which is named regression equation. Gauss and Legendre used the least-squares methods which is the basic mathematical tool in order to calculate the length of the arc of the meridian from Dunkirk to Barcelona [29]. The first progress for regression is made by Francis Galton to investigate the relationship the height of children and their parents. He observed that the height of the children of short parents tended to be short and height of the children of long parents tended to be long. Also, he found that the height of his children tended to approach the mean of the mass average. This tendency is called “regression to mediocrity” by Galton. This study is the first regression analysis [30].

3.1 Regression Models

One of the basic elements of regression analysis is the regression model. A model is a mathematical function that describes the experimental system in which quantitative terms are studied. In general, a model is represented as;

$$y = f(x; a) \quad (3.1)$$

Generally, the models have three basic components: mathematical relationship or function (f), parameters (a) and variables (x). In the most common cases, they have only one or two independent variables, and are simple from real-valued continuous equations. These include exponential, hyperbolic and logistic functions. The same functions can also be used to model completely irrelevant events from existing physical processes.

Depending on how the function is derived, the models can be classified into two groups. One of them is structured or mechanistic models and the another is unstructured or empirical models.

Structured models can be obtained from the theoretical background of the mechanism. Unstructured models are chosen from empirical functions. Because they are useful in explaining measurements. A third group of semi-empirical models is classified between these two types, since they are derived from theoretical considerations and partly from observations [31].

Another component of the models is parameters. When the function determines the type of curve, its actual shape, position and ratio are determined by the parameter values. In mechanical and semi-empirical models, the parameters are fundamentally important as they represent proportions or diffusion coefficients. In empirical models, the parameters are necessary to define the curve precisely and more efficiently, but do not represent any fundamental feature of the system.

Depending on the mathematical expression of the parameters within the model function, we can classify the models in two categories as linear and nonlinear. This distinction is important. Since the methodology required for the operation of mathematical models generated by nonlinear functions is much more complex than linear models. Secondly, linear models are often easy to handle and understand, although they can be used to model only a few phenomenon in real life.

The functions may also be linear or non-linear according to their independent variables. Any combination of linearity or non-linearity is available according to variables and parameters.

In the context of this thesis, due to the complexity of the problem, nonlinear regression models were preferred.

3.2. Purpose of Regression Analysis

Nonlinear regression can be used for three different purposes:

- Testing the validity of the model (or comparing the hypothesis),
- Characterize the model (in other words to estimate the parameters),
- Estimating the behavior of the system (interpolation and calibration).

Model validation or comparison is an important application of regression analysis. Reaching a well-fitting curve between model and experiment data for a system is one of the best indicators of the success of the mathematical model. But a good fit is not always a proof that the model is correct. At this stage, action of the researcher is significantly important to build meaningful work.

The estimation of the parameters is a direct result of regression. Regression is useful for predicting behavior, i.e. interpolation (or prediction) and calibration (or inverse prediction). Interpolation and extrapolation can be used to predict the behavior of the system without having to perform real experiments.

3.3. Non-Linear Regression Analysis

Nonlinear regression is more flexible than linear regression. Since the function does not need to be linear or linearizable. For this reason, it provides a wide selection of nonlinear regression phenomena to fit the data. The only requirement for the function “f” is that it differs according to its elements. This can be calculated with the least squares method. Nonlinear regression may be more appropriate than the use of transformations and linear regression where the f function can be linearized.

For nonlinear regression, mathematical modeling processes can be carried out systematically by taking into consideration the important features.

Nonlinear regression requires knowledge of the function “f” which requires a comprehensive understanding of the process under consideration (polynomial, trigonometric, exponential, etc.). The linear regression models are suitable for process estimations, which are roughly defined, but do not require precise clarity.

The nonlinear regression model can be expressed as;

$$y_i = f(y_i; x) + \varepsilon_i \quad (3.2)$$

It is assumed that the ε error term can be taken independently and is normally distributed. Since nonlinear regression models contain the most general mathematical expressions, it is not possible to write their functionalized generalized form. However, a few basic types of the function used in the field of engineering can be expressed as below:

Polynomial type function:

$$y = a_0 + a_1x + a_2x^2 + \dots + a_nx^n \quad (3.3)$$

Exponential type function:

$$y = a_0 + a_1e^x + a_2e^{x^2} + \dots + a_n e^{x^n} \quad (3.4)$$

Trigonometric type function:

$$y = a_0 + a_1\sin x + a_2\sin x^2 + \dots + a_n\sin x^n \quad (3.5)$$

Logarithmic type function:

$$y = a_0 + a_1\ln x + a_2\ln x^2 + \dots + a_n\ln x^n \quad (3.6)$$

Rational type function:

$$y = \frac{a_0 + a_1x + a_2x^2 + \dots + a_nx^n}{b_0 + b_1x + b_2x^2 + \dots + b_nx^n} \quad (3.7)$$

At this stage, the multivariate states of the above model types can be derived with similar logic with more than one input. Another important point is that, for example, special functions or different combinations of elementary functions can be selected as model structures by acquiring a broader understanding of the families of mathematical functions.

CHAPTER 4

MATHEMATICAL MODEL

4.1. Mathematical Models

In this part of the thesis study, it is aimed to develop a mathematical model for optimum surface roughness as a function of the cutting input parameters which are spindle speed, depth of cut and feed-rate, presented in Table 4.1.

Figure 4.1 shows these cutting parameters in milling process. As mentioned in the previous section, in this study cutting parameters effecting the surface quality have been investigated for the average surface roughness. The output parameter in the analysis is the average surface roughness (R_a).

Table 4.1 Input and output parameters

Variable Type	Parameter	Unit
Input	Spindle Speed (n)	rev/min (rpm)
Input	Depth of Cut (a)	mm
Input	Feed Rate (f)	mm/min
Output	Average Surface Roughness (R_a)	μm

In this part of study, set of experiments used to carry out regression analysis was taken from the literature, the study of N. Liu et al. based on the statistical principles presented in Table 4.2 [32].

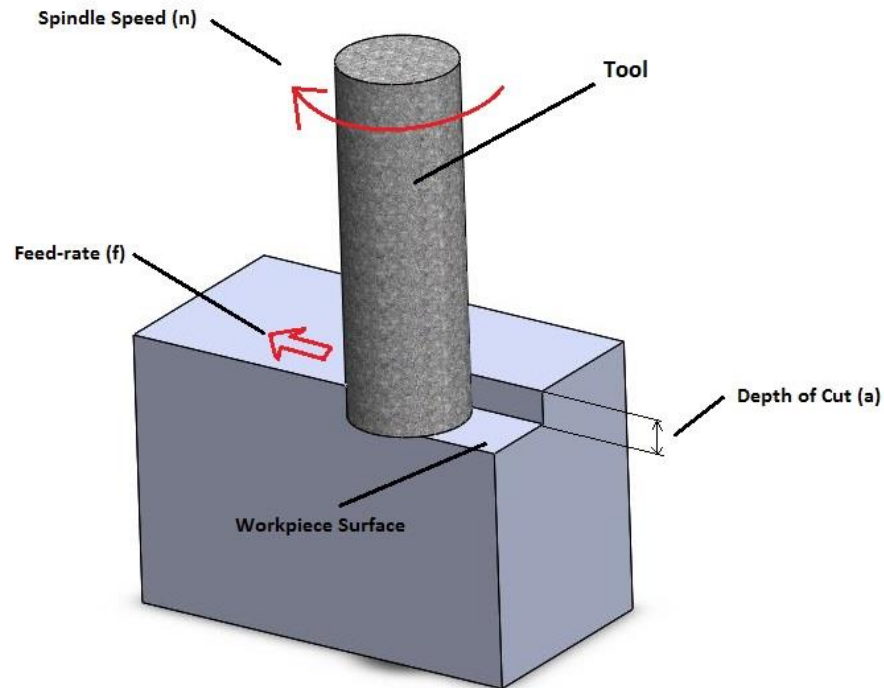

Figure 4.1 Schematic illustration of a milling process

A mathematical model of the process was developed to determine the optimum values of cutting parameters. Non-linear multivariate regression has been used for this purpose. Then, the mathematical model obtained from analysis will be used to optimize the process and to determine the effect of the parameters on the surface roughness.

In this study, while the average roughness modeling was performed, the standard non-linear multiple regression analysis and stochastic optimization methods were used as hybrid. Therefore, 18 experimental data were used for regression modeling and the accuracy of the mathematical model was obtained.

The regression equations in the studies in the literature solve different physical problems. The appropriate mathematical model should be selected for this problem. For this reason, in order to define the average surface roughness, a mathematical model is required to define the objective function in terms of feed (f), spindle speed (n) and depth of cut (a). For this purpose, seven different linear and non-linear structurally different regression models have been decided to be used as seen in Table 4.3 and the formulations of the models in Table 4.4.

Table 4.2 Experimental data used to carry out regression analysis [32]

Number of Experiment	Input			Output
	n (rpm)	a (mm)	f (mm/min)	R _a (μm)
1	1000	1	75	0.249
2	1000	1	100	0.302
3	1000	2	50	0.195
4	1000	2	100	0.248
5	1000	3	50	0.169
6	1000	3	75	0.219
7	1500	1	50	0.16
8	1500	1	100	0.222
9	1500	2	50	0.136
10	1500	2	75	0.194
11	1500	3	75	0.168
12	1500	3	100	0.203
13	2000	1	50	0.111
14	2000	1	75	0.153
15	2000	2	75	0.158
16	2000	2	100	0.19
17	2000	3	50	0.081
18	2000	3	100	0.171

In the selected models, both elementary and rational models were selected. Rational models are used for boundedness and the values that make the denominator zero are the limits of rational models.

Note that, in Table 4.4, x_1 , x_2 and x_3 represent spindle speed (n), depth of cut (a), and feed rate (f), respectively. The terms a_i and b_i ($i=0,1,2,\dots,18$) represent the coefficients to be determined using least squares.

Table 4.3 Different mathematical models

Model Number	Model Name
1	Third order multiple nonlinear rational
2	First order trigonometric linear
3	First order trigonometric linear rational
4	Second order multiple nonlinear
5	Second order multiple nonlinear rational
6	Second order logarithmic multiple nonlinear rational
7	Third order logarithmic multiple nonlinear rational

The average surface roughness values have been obtained from different mathematical models. In order to solve the problem, the coefficients of the equation were obtained with the “Findfit” command in Mathematica as;

$$\text{Constants} = \text{FindFit}[\text{data}, \text{formula of the model}, \text{coefficient}, \text{variables}] \quad (4.1)$$

Then the coefficients were replaced by different models and the responses of the different input values of that model were taken.

Findfit command finds a local optimal fit for nonlinear structures. In the linear case it finds a global optimal point. In this study, quasi-Newton method has been selected. Because quasi-Newton method is more reliable and applicable for nonlinear models.

The predictions of average roughness values based on models 1-7 for each experiment are represented in Table 4.5. The percentages of the differences between the actual and prediction values for the 18 data are given in Table 4.6 and 4.7. In these tables, R_{a_i} represents the predicted average surface roughness, ϵ_i is the percentage of error according to the experimental values R_a^* , where i is the model number and ϵ_a is the average error.

Table 4.4 Formulations for different mathematical models

Model Number	Formulations
1	$\frac{(a_0 + a_1x_1 + a_2x_2 + a_3x_3 + a_4x_1x_2 + a_5x_2x_3 + a_6x_1x_3 + a_7x_1^2 + a_8x_2^2 + a_9x_3^2 + a_{10}x_1^3 + a_{11}x_2^3 + a_{12}x_3^3 + a_{13}x_1^2x_2 + a_{14}x_2^2x_3 + a_{15}x_3^2x_1 + a_{16}x_1^2x_3 + a_{17}x_2^2x_1 + a_{18}x_3^2x_2)}{(b_0 + b_1x_1 + b_2x_2 + b_3x_3 + b_4x_1x_2 + b_5x_2x_3 + b_6x_1x_3 + b_7x_1^2 + b_8x_2^2 + b_9x_3^2 + b_{10}x_1^3 + b_{11}x_2^3 + b_{12}x_3^3 + b_{13}x_1^2x_2 + b_{14}x_2^2x_3 + b_{15}x_3^2x_1 + b_{16}x_1^2x_3 + b_{17}x_2^2x_1 + b_{18}x_3^2x_2)}$
2	$a_0 + a_1 \sin x_1 + a_2 \sin x_2 + a_3 \sin x_3 + a_4 \cos x_1 + a_5 \cos x_2 + a_6 \cos x_3$
3	$\frac{(a_0 + a_1 \sin x_1 + a_2 \sin x_2 + a_3 \sin x_3 + a_4 \cos x_1 + a_5 \cos x_2 + a_6 \cos x_3)}{(b_0 + b_1 \sin x_1 + b_2 \sin x_2 + b_3 \sin x_3 + b_4 \cos x_1 + b_5 \cos x_2 + b_6 \cos x_3)}$
4	$a_0 + a_1x_1 + a_2x_2 + a_3x_3 + a_4x_1x_2 + a_5x_2x_3 + a_6x_1x_3 + a_7x_1^2 + a_8x_2^2 + a_9x_3^2$
5	$\frac{(a_0 + a_1x_1 + a_2x_2 + a_3x_3 + a_4x_1x_2 + a_5x_2x_3 + a_6x_1x_3 + a_7x_1^2 + a_8x_2^2 + a_9x_3^2)}{(b_0 + b_1x_1 + b_2x_2 + b_3x_3 + b_4x_1x_2 + b_5x_2x_3 + b_6x_1x_3 + b_7x_1^2 + b_8x_2^2 + b_9x_3^2)}$
6	$\frac{(a_0 + a_1 \log x_1 + a_2 \log x_2 + a_3 \log x_3 + a_4 \log x_1 \log x_2 + a_5 \log x_2 \log x_3 + a_6 \log x_1 \log x_3 + a_7 \log x_1^2 + a_8 \log x_2^2 + a_9 \log x_3^2)}{(b_0 + b_1 \log x_1 + b_2 \log x_2 + b_3 \log x_3 + b_4 \log x_1 \log x_2 + b_5 \log x_2 \log x_3 + b_6 \log x_1 \log x_3 + b_7 \log x_1^2 + b_8 \log x_2^2 + b_9 \log x_3^2)}$
7	$\frac{(a_0 + a_1 \log x_1 + a_2 \log x_2 + a_3 \log x_3 + a_4 \log x_1 \log x_2 + a_5 \log x_2 \log x_3 + a_6 \log x_1 \log x_3 + a_7 \log x_1^2 + a_8 \log x_2^2 + a_9 \log x_3^2 + a_{10} \log x_1^2 \log x_2 + a_{11} \log x_2^2 \log x_3 + a_{12} \log x_1^2 \log x_3 + a_{13} \log x_3^2 \log x_2 + a_{14} \log x_2^2 \log x_1 + a_{15} \log x_3^2 \log x_1 + a_{16} \log x_1^3 + a_{17} \log x_2^3 + a_{18} \log x_3^3)}{(b_0 + b_1 \log x_1 + b_2 \log x_2 + b_3 \log x_3 + b_4 \log x_1 \log x_2 + b_5 \log x_2 \log x_3 + b_6 \log x_1 \log x_3 + b_7 \log x_1^2 + b_8 \log x_2^2 + b_9 \log x_3^2 + b_{10} \log x_1^2 \log x_2 + b_{11} \log x_2^2 \log x_3 + b_{12} \log x_1^2 \log x_3 + b_{13} \log x_3^2 \log x_2 + b_{14} \log x_2^2 \log x_1 + b_{15} \log x_3^2 \log x_1 + b_{16} \log x_1^3 + b_{17} \log x_2^3 + b_{18} \log x_3^3)}$

Table 4.5 Experimental(R_a^*) and Predicted (R_a) values for models 1 to 7

Number of Experiment	R_a^* (μm)	R_{a1} (μm)	R_{a2} (μm)	R_{a3} (μm)	R_{a4} (μm)	R_{a5} (μm)	R_{a6} (μm)	R_{a7} (μm)
1	0.249	0.251	0.25	0.251	0.259	0.253	0.256	0.256
2	0.302	0.281	0.283	0.299	0.283	0.284	0.284	0.283
3	0.195	0.191	0.189	0.196	0.195	0.197	0.194	0.194
4	0.248	0.268	0.27	0.253	0.263	0.271	0.265	0.265
5	0.169	0.169	0.171	0.169	0.169	0.175	0.171	0.171
6	0.219	0.219	0.219	0.217	0.214	0.221	0.215	0.216
7	0.16	0.159	0.152	0.155	0.156	0.164	0.151	0.151
8	0.222	0.23	0.233	0.226	0.231	0.228	0.232	0.233
9	0.136	0.138	0.139	0.146	0.14	0.143	0.14	0.14
10	0.194	0.185	0.188	0.18	0.188	0.185	0.188	0.188
11	0.168	0.171	0.169	0.172	0.169	0.171	0.169	0.169
12	0.203	0.206	0.202	0.204	0.2	0.204	0.199	0.199
13	0.111	0.116	0.116	0.111	0.108	0.12	0.109	0.11
14	0.153	0.163	0.164	0.162	0.16	0.162	0.163	0.164
15	0.158	0.149	0.151	0.156	0.151	0.148	0.153	0.153
16	0.19	0.183	0.184	0.18	0.185	0.179	0.185	0.185
17	0.081	0.08	0.085	0.08	0.085	0.082	0.086	0.085
18	0.171	0.172	0.165	0.173	0.174	0.168	0.168	0.168

Table 4.6 Average prediction error of the models

Model Number	ϵ_a Average error (%)
1	2.93
2	3.43
3	2.29
4	2.98
5	3.63
6	3.24
7	3.19

In table 4.6, the biggest average error in Model 5 with the average error 3.63 % among the seven models and the smallest error in Model 3 with average error 2.29 % .

Table 4.7 Prediction errors (%) of the models

Number of Experiment	ϵ_1	ϵ_2	ϵ_3	ϵ_4	ϵ_5	ϵ_6	ϵ_7
1	0.8	0.44	0.92	3.98	1.70	2.86	2.64
2	7.06	6.42	1.09	6.32	6.11	6.00	6.18
3	2.15	2.93	0.30	0.25	0.84	0.63	0.71
4	7.41	8.13	1.92	5.71	8.47	6.31	6.39
5	0.06	1.14	0.27	0.20	3.27	1.01	1.33
6	0.13	0.05	0.89	2.47	1.09	1.80	1.46
7	0.92	4.93	3.38	2.68	2.34	5.51	5.54
8	3.34	4.63	1.74	3.78	2.62	4.47	4.56
9	1.74	2.47	6.71	2.52	4.82	3.03	2.62
10	4.42	3.29	7.08	3.26	4.51	2.92	2.99
11	1.59	0.76	2.11	0.80	1.47	0.62	0.67
12	1.42	0.60	0.61	1.48	0.73	2.09	1.97
13	4.37	3.99	0.27	2.29	7.47	1.54	0.90
14	5.99	6.58	5.78	4.30	5.51	6.20	6.57
15	5.78	4.36	1.18	4.31	6.54	2.89	3.12
16	3.83	3.36	5.18	2.59	5.55	2.70	2.74
17	1.30	4.27	0.80	4.85	0.78	5.90	5.08
18	0.37	3.35	1.02	1.87	1.54	1.89	1.96

4.2. Coefficient of Determination

The coefficient of determination (R^2) is simply the proportion of observed y variation which is observed by the simple linear regression model. R^2 is a ratio and the higher this ratio indicates that the regression model explains the variability for the observed values better. If the value of R^2 is so small, then another model is established to explain the variation. Usually this model is selected as a non-linear or multiple regression model containing multiple independent variables. Although this value is not a fixed value in the literature, it is expected to be above 0.90.

The calculation of the R^2 is given below [33].

$$R^2 = 1 - \frac{SSE}{SST} \quad (4.2)$$

where SSE is the sum of squares due to error and SST is the total sum of squares.

The sum of squares due to regression (SSR) is calculated by using the formula given in Equation 4.3. Sum of squares due to error (SSE) is calculated by Equation 4.4. The Total Sum of Squares (SST) is sum of SSR and SSE in Equation 4.5. In this notation the population mean is \bar{y} , prediction mean is \hat{y} and y is the observation value.

$$SSR = \sum (\hat{y} - \bar{y}) \quad (4.3)$$

$$SSE = \sum (y - \hat{y})^2 \quad (4.4)$$

$$SST = SSR + SSE = \sum (y - \bar{y}) \quad (4.5)$$

SSR is the measure of explained variation, SSE (sum of the squared errors) is the measure of unexplained variation and SST (total sum of squares) is the measure of total variation in y [34].

Table 4.8 shows the regression estimates which gives R^2 values with various functions. This table is an indicator of how each function behaves to fit the regression model.

In this study, the third mathematical model (first order trigonometric linear rational) provides the best R^2 values and therefore it is best for this model to comply with the required regression equation.

Table 4.8 R^2 values for mathematical models

Model Number	SSE (Sum of squares due to error)	SST (The total sum of squares)	R^2 (Coefficient of determination)
1	0.0013	0.0466	0.9725
2	0.0014	0.0466	0.9699
3	0.0006	0.0466	0.9876
4	0.0010	0.0466	0.9778
5	0.0015	0.0466	0.9679
6	0.0011	0.0466	0.9759
7	0.0010	0.0466	0.9753

4.3. Adjusted Coefficient of Determination

R^2 value shows only how well data points fit a curve. Adjusted coefficient of determination (R_{adj}^2) also indicates how well terms fit a curve but adjusts for the number of terms in a model. If more meaningless variables are added to the model, R_{adj}^2 value decreases and it increases if more meaningful variables are added. R_{adj}^2 is calculated using the expression given as;

$$R_{adj}^2 = 1 - \frac{(1 - R^2)(n - 1)}{n - k - 1} \quad (4.6)$$

where n indicates that the number of points in the data sample, k is the number of independent regressors which is the number of variables in the model, excluding the constant. R_{adj}^2 is always smaller than R^2 values. By adding much more independent variables to model, R_{adj}^2 value does not increase. This value especially gives an understanding for the adequacy of mathematical model. But these two values are not enough to prove that the mathematical model is at usable level [34].

R_{adj}^2 values have been calculated according to the different types of model in the Table 4.9.

Table 4.9 R_{adj}^2 values for 7 models

Model Number	R^2	R_{adj}^2	Difference between R^2 and R_{adj}^2 (%)
1	0.9725	0.9665	0.6170
2	0.9699	0.9635	0.6599
3	0.9876	0.9849	0.2734
4	0.9778	0.9730	0.4909
5	0.9679	0.9611	0.7026
6	0.9759	0.9707	0.5328
7	0.9753	0.9700	0.5434

4.4. Training and Testing

The mathematical model should be trained with training data set. The purpose of training is to investigate the model for testing. Splitting a dataset into training and testing datasets is important for better prediction the phenomena. By comparing the predictions to the actual response variable in the test data, it will be able to evaluate model's accuracy.

The gold standard for evaluating the ability of mathematical model to predict the phenomena is to use independent test set. The model has a probability to fit the data for selected training data set. However, model performance determined by testing the model with an external test data which is chosen from data set [35].

The training study is done with approximately 80% of randomly selected experimental data. In this thesis, four randomly selected data have been removed from the data set. 3, 8,11 and 15th lines have been removed from data set and this corresponds approximately 78% of data. The training set is listed in Table 4.10.

Table 4.10 Training data set

Number of Experiment	Input			Output
	n (rpm)	a (mm)	f (mm/min)	R _a (μm)
1	1000	1	75	0.249
2	1000	1	100	0.302
4	1000	2	100	0.248
5	1000	3	50	0.169
6	1000	3	75	0.219
7	1500	1	50	0.16
9	1500	2	50	0.136
10	1500	2	75	0.194
12	1500	3	100	0.203
13	2000	1	50	0.111
14	2000	1	75	0.153
16	2000	2	100	0.19
17	2000	3	50	0.081
18	2000	3	100	0.171

The coefficient of determination and adjusted coefficient determination value for training data are R^2_{training} and $R^2_{\text{training}_{\text{adj}}}$ respectively.

R^2_{training} and $R^2_{\text{training}_{\text{adj}}}$ values being close indicates that the number of lines in the data set is sufficient for training study. For all mathematical models, the data set is sufficient at this stage and the results are listed in Table 4.11.

Table 4.11 R^2_{training} and $R^2_{\text{training}_{\text{adj}}}$ values for 7 models

Model Number	R^2	R^2_{training}	$R^2_{\text{training}_{\text{adj}}}$	% Difference between R^2_{training} and $R^2_{\text{training}_{\text{adj}}}$
1	0.9725	0.9584	0.9459	1.3043
2	0.9699	0.9790	0.9727	0.6435
3	0.9876	0.9903	0.9875	0.2827
4	0.9778	0.9868	0.9828	0.4054
5	0.9679	0.9582	0.9457	1.3045
6	0.9759	0.9793	0.9731	0.6331
7	0.9753	0.9790	0.9728	0.6333

The testing procedure is based on testing the model obtained by training on the available data. The purpose of the testing procedure is to test whether the all data is in a mathematical relationship. Because the model is being established with training data set again. However, the training model is established with the same data. The purpose of a random data test is to see how much the model has changed.

As a result; the model established with data for both training and testing should be able to define the problem as a whole. If the lines for training and testing create a different mathematical model, it can be concluded that the main model cannot identify the problem precisely. The greater coefficient of determination value for testing data (R^2_{testing}) means that the main model predicts phenomena better than others. R^2_{testing} values are shown in Table 4.12. After the testing, sixth mathematical model has a good predictive power compared to another models.

Table 4.12 R^2_{testing} values for the selected models

Model Number	R^2	R^2_{testing}
1	0.9725	0.7116
2	0.9699	0.5338
3	0.9876	0.2803
4	0.9778	0.2472
5	0.9679	0.7274
6	0.9759	0.8711
7	0.9753	0.8645

4.5. Stability Analysis of Mathematical Models

Statistical stability has been considered to have a challenge for the mathematical laws and probability theory. The minimum and maximum limits of a function determine the behavior of the function. At the smallest incremental values of the input, the output is expected to give meaningful results. At the same time, there should be no values that cannot actually be realized [36].

Model 3 seems the most appropriate for the regression equation for considering R^2 values in Table 4.8. However, this analysis is only made for selected data. The values at different points should be examined. Therefore, stability analysis is applied to the mathematical models. It is observed that the result changes by decreasing and increasing the input values.

The important point here is to analyze the values considering experimentally. It should also be observed that the mathematical model results in different input values. Because in some mathematical models the coefficients are so large that even if different input values are entered, the result is not changed. These are undesirable situations in the mathematical model.

To avoid undesirable solutions, the output values of each mathematical model, which corresponds to the modified input values (A, B, C, D), are listed in Tables 4.13-19. In these tables, R_a^* is the experimental average roughness value, **A** is the average roughness value according to 20% reduced of input variables, **B** is the average roughness

value according to 10% reduced of input variables, **C** is the average roughness value according to 10% increased of input variables, and **D** is the average roughness value according to 20% increased of input variables.

Table 4.13 Stability analysis for Model 1.

Number of Experiment	R_a^* (μm)	A (μm)	B (μm)	C (μm)	D (μm)
1	0.249	0.247	0.247	0.247	0.247
2	0.302	0.281	0.281	0.281	0.281
4	0.248	0.268	0.268	0.268	0.268
5	0.169	0.156	0.156	0.156	0.156
6	0.219	0.217	0.217	0.216	0.216
7	0.160	0.145	0.145	0.145	0.145
9	0.136	0.130	0.130	0.130	0.130
10	0.194	0.187	0.187	0.187	0.187
12	0.203	0.216	0.215	0.215	0.215
13	0.111	0.113	0.113	0.112	0.112
14	0.153	0.164	0.164	0.164	0.164
16	0.190	0.193	0.193	0.193	0.193
17	0.081	0.089	0.089	0.089	0.089
18	0.171	0.183	0.183	0.183	0.183

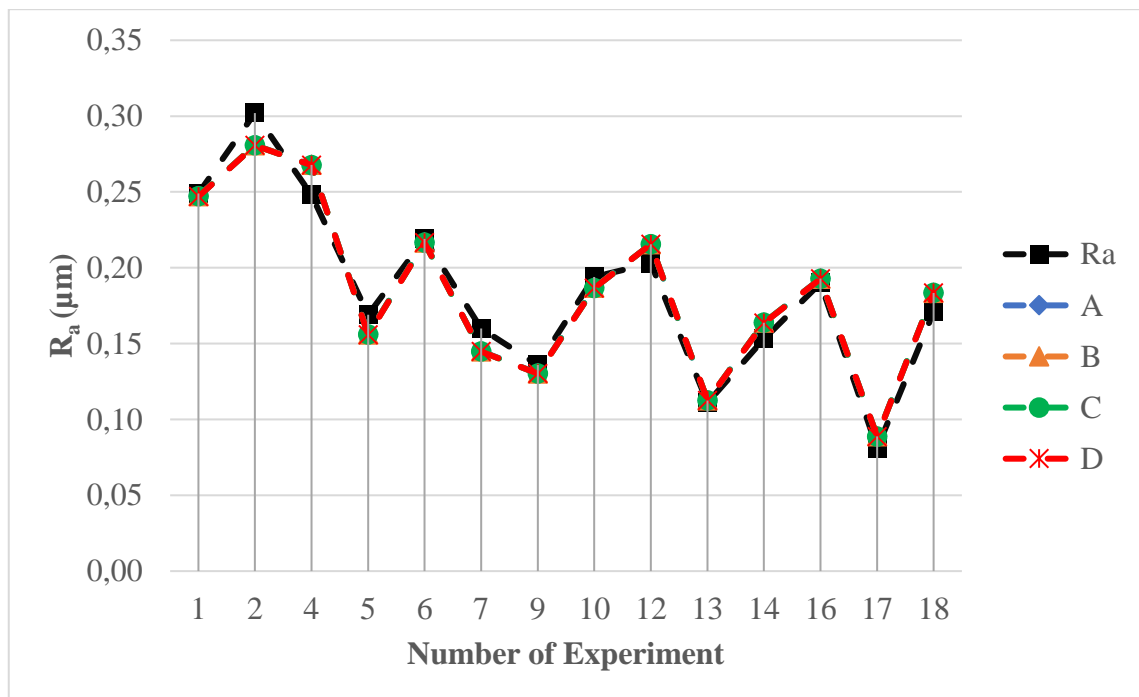

Figure 4.2 Stability analysis for Model 1.

When the stability analysis is examined, it is observed that the outputs of the first model do not change as seen in Figure 4.2. Although the mathematical model predicts with 2.93% error for 18 inputs, it does not respond to different input values.

Table 4.14 Stability analysis for Model 2.

Number of Experiment	R _a (μm)	A (μm)	B (μm)	C (μm)	D (μm)
1	0.249	-0.698	0.116	-0.425	-0.993
2	0.302	0.040	-108356	-0.736	-0.275
4	0.248	0.023	-110347	-0.760	-0.300
5	0.169	-117528	-0.672	0.192	-0.590
6	0.219	-0.731	0.081	-0.456	-101949
7	0.160	-0.999	-0.567	0.080	-0.748
9	0.136	-101651	-0.586	0.056	-0.773
10	0.194	-0.573	0.167	-0.593	-12024
12	0.203	0.150	-104708	-0.912	-0.487
13	0.111	-113784	-0.725	0.195	-0.564
14	0.153	-0.694	0.028	-0.453	-0.993
16	0.190	0.027	-119116	-0.789	-0.300
17	0.081	-117085	-0.760	0.164	-0.590
18	0.171	0.011	-120581	-0.796	-0.302

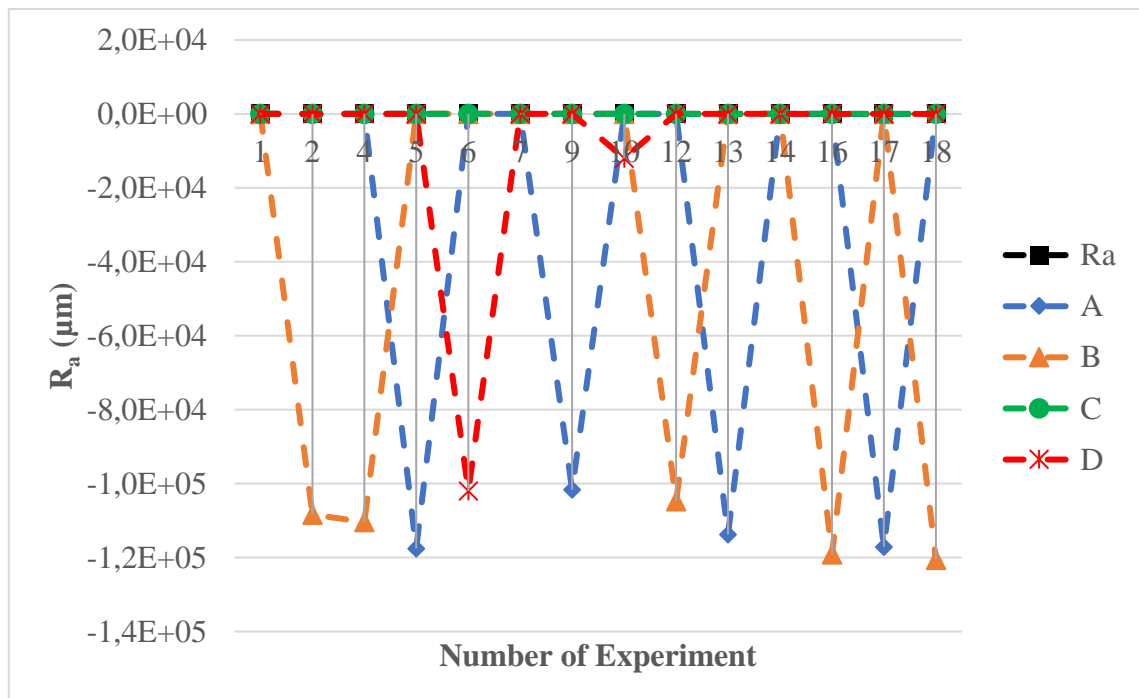

Figure 4.3 Stability analysis for Model 2.

When the second model is examined, values that cannot be obtained experimentally are observed as seen in Figure 4.3. Due to the terms in the trigonometric function, it is observed that this model cannot define the phenomenon.

Table 4.15 Stability analysis for Model 3.

Number of Experiment	R_a^* (μm)	A (μm)	B (μm)	C (μm)	D (μm)
1	0.249	0.132	0.143	0.127	0.130
2	0.302	0.140	0.128	0.133	0.129
4	0.248	0.139	0.127	0.133	0.128
5	0.169	0.127	0.123	0.149	0.134
6	0.219	0.131	0.142	0.126	0.129
7	0.160	0.130	0.127	0.141	0.131
9	0.136	0.130	0.127	0.140	0.131
10	0.194	0.135	0.147	0.119	0.125
12	0.203	0.147	0.129	0.130	0.113
13	0.111	0.128	0.120	0.148	0.135
14	0.153	0.132	0.138	0.126	0.130
16	0.190	0.140	0.126	0.133	0.128
17	0.081	0.127	0.119	0.147	0.134
18	0.171	0.139	0.125	0.132	0.127

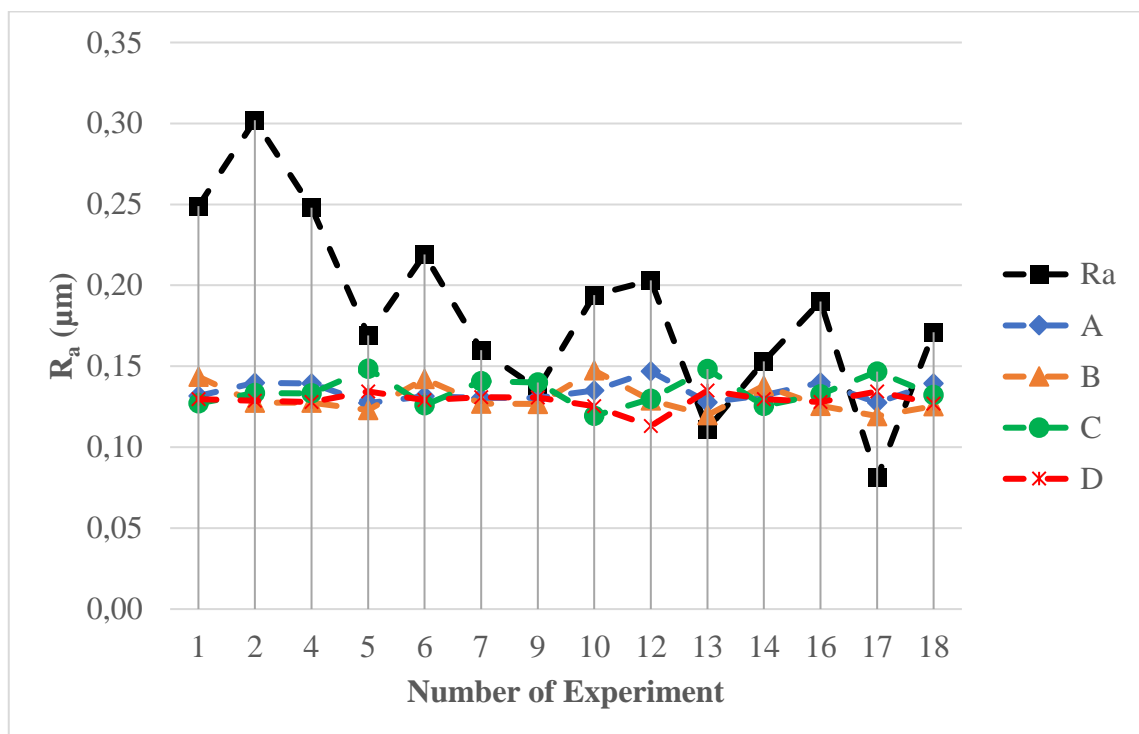

Figure 4.4 Stability analysis for Model 3.

The reason for the fact that the output values in the third model are gathered around a single line is described to due to the coefficients in the rational trigonometric function as seen in Figure 4.4. For only 18 selected data, the coefficients are correct, which represents the error is low. However, the rest of continuous values is not valid.

Table 4.16 Stability analysis for Model 4.

Number of Experiment	R_a^* (μm)	A (μm)	B (μm)	C (μm)	D (μm)
1	0.249	0.248	0.251	0.256	0.258
2	0.302	0.284	0.289	0.296	0.297
4	0.248	0.255	0.257	0.258	0.256
5	0.169	0.171	0.171	0.173	0.175
6	0.219	0.206	0.208	0.211	0.213
7	0.160	0.170	0.165	0.153	0.146
9	0.136	0.151	0.145	0.132	0.126
10	0.194	0.193	0.190	0.184	0.179
12	0.203	0.211	0.210	0.206	0.203
13	0.111	0.129	0.117	0.090	0.076
14	0.153	0.179	0.172	0.155	0.145
16	0.190	0.196	0.191	0.177	0.168
17	0.081	0.103	0.093	0.074	0.065
18	0.171	0.181	0.176	0.164	0.157

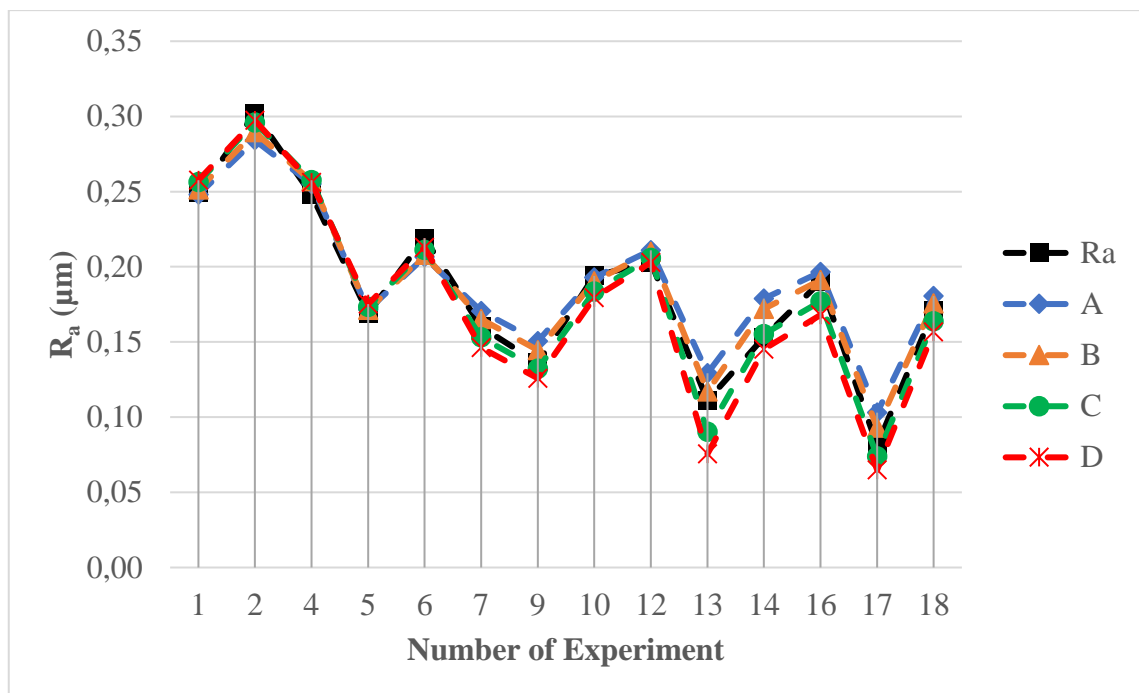

Figure 4.5 Stability analysis for Model 4.

As seen in Figure 4.5, in the fourth model, the result does not change for some points. For the majority, the model may show variability when inputs change. However, this is undesirable solution.

Table 4.17 Stability analysis for Model 5.

Number of Experiment	R _a (μm)	A (μm)	B (μm)	C (μm)	D (μm)
1	0.249	0.247	0.247	0.247	0.247
2	0.302	0.280	0.280	0.280	0.280
4	0.248	0.268	0.268	0.268	0.268
5	0.169	0.158	0.158	0.158	0.158
6	0.219	0.218	0.218	0.218	0.218
7	0.160	0.144	0.144	0.144	0.144
9	0.136	0.131	0.131	0.130	0.130
10	0.194	0.187	0.187	0.187	0.187
12	0.203	0.216	0.216	0.216	0.216
13	0.111	0.112	0.112	0.112	0.112
14	0.153	0.163	0.163	0.163	0.163
16	0.190	0.193	0.193	0.192	0.192
17	0.081	0.089	0.089	0.089	0.089
18	0.171	0.184	0.184	0.184	0.184

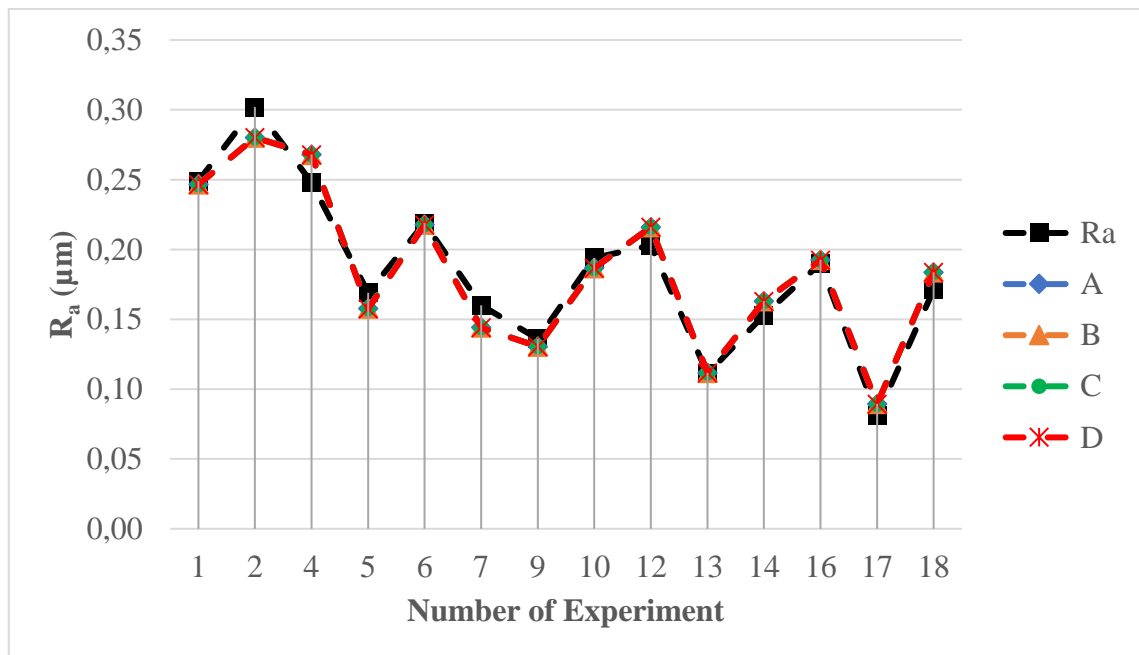

Figure 4.6 Stability analysis for Model 5.

In fifth model, it is observed that the outputs of the model do not change (see Figure 4.6). Although the mathematical model predicts with 3.63% error for selected data, it does not respond to different input values.

Table 4.18 Stability analysis for Model 6.

Number of Experiment	R_a^* (μm)	A (μm)	B (μm)	C (μm)	D (μm)
1	0.249	0.270	0.264	0.255	0.250
2	0.302	0.301	0.294	0.283	0.278
4	0.248	0.278	0.270	0.256	0.251
5	0.169	0.182	0.176	0.165	0.161
6	0.219	0.230	0.222	0.209	0.204
7	0.160	0.153	0.152	0.150	0.149
9	0.136	0.143	0.139	0.134	0.131
10	0.194	0.196	0.191	0.183	0.179
12	0.203	0.212	0.206	0.195	0.191
13	0.111	0.106	0.108	0.109	0.110
14	0.153	0.169	0.168	0.165	0.164
16	0.190	0.194	0.189	0.181	0.178
17	0.081	0.090	0.088	0.084	0.082
18	0.171	0.179	0.174	0.166	0.162

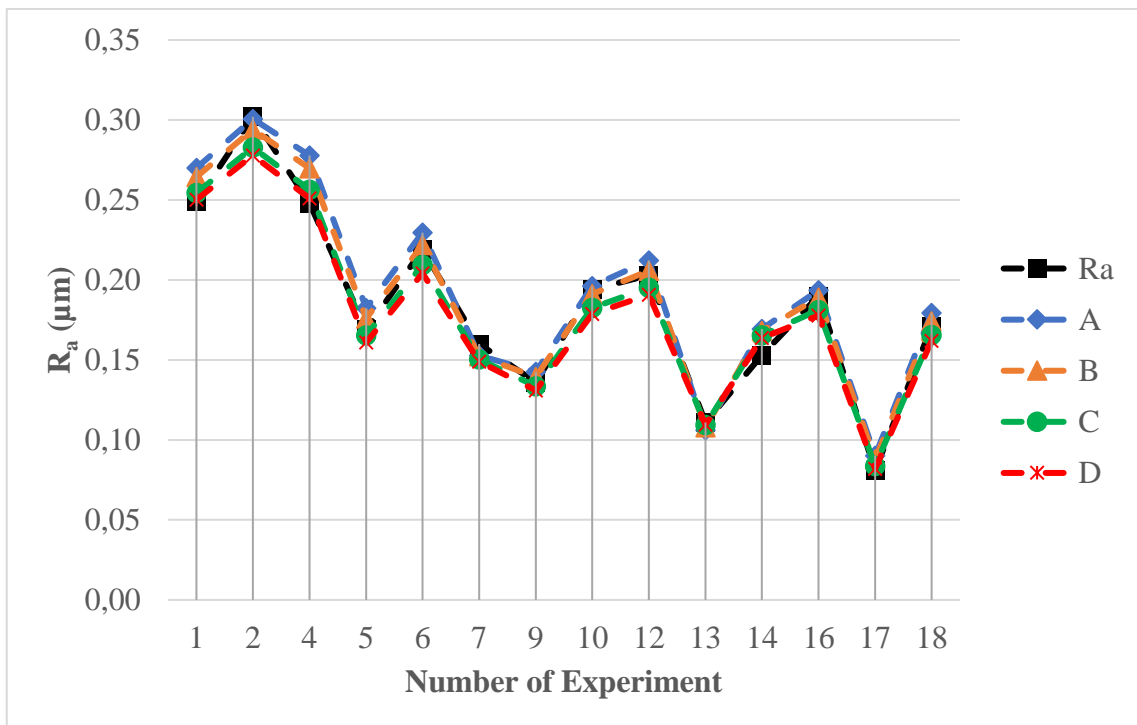

Figure 4.7 Stability analysis for Model 6.

Table 4.19 Stability analysis for Model 7.

Number of Experiment	R_a^* (μm)	A (μm)	B (μm)	C (μm)	D (μm)
1	0.249	0.269	0.264	0.254	0.250
2	0.302	0.300	0.294	0.283	0.278
4	0.248	0.278	0.270	0.257	0.251
5	0.169	0.183	0.176	0.166	0.161
6	0.219	0.230	0.222	0.209	0.204
7	0.160	0.152	0.152	0.150	0.149
9	0.136	0.142	0.139	0.133	0.131
10	0.194	0.196	0.191	0.182	0.179
12	0.203	0.212	0.206	0.195	0.190
13	0.111	0.107	0.108	0.110	0.110
14	0.153	0.170	0.169	0.166	0.164
16	0.190	0.193	0.189	0.181	0.178
17	0.081	0.090	0.088	0.084	0.082
18	0.171	0.179	0.174	0.165	0.162

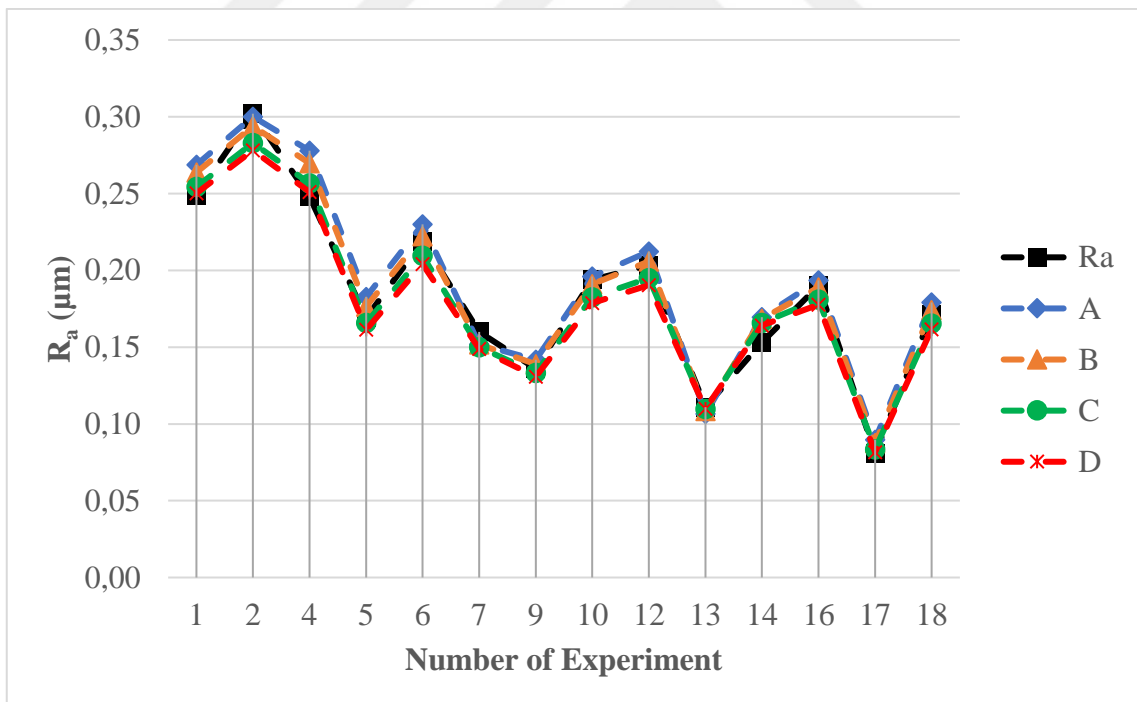

Figure 4.8 Stability analysis for Model 7.

In the sixth and seventh mathematical models, the stability graphics, Figure 4.7 and Figure 4.8, are similar. For this reason, testing of coefficient of determination values should be examined. The analysis results are presented in Table 4.12. At this point, it has

been observed that the sixth model testing value is higher than the seventh model. As a result of the regression analysis, the sixth mathematical model is the most suitable among the seven models for optimization. In the next step, the regression model should be optimized and different stochastic optimization methods should be applied for the desired average surface roughness value in terms of spindle speed, depth of cut and feed rate.



CHAPTER 5

OPTIMIZATION

Optimization is a procedure in which the best possible values of design variables are obtained under a set of constraints and in accordance with a selected optimization target function. The most common optimization procedure in the field of engineering is to minimize the total cost or maximize the potential reliability and quality. Design problems in engineering include many situations that require the optimization approach to be implemented. For this reason, using an effective optimization algorithm to find the best solution on a systematic basis is considered as a success criterion for an engineer.

Many optimization algorithms are available to solve design problems. They can be classified as traditional and non-traditional methods. Traditional methods are mostly gradient based (they require derivative information of functions) and formulate the problem with a deterministic approach. For this reason, they are not preferred for problems with more complex and long mathematical structures that include nonlinear functions. Methods such as restricted variation and Lagrange multipliers are analytical and can be given as examples of traditional methods [37]. Non-traditional methods which use stochastic processes and intuition-based search techniques conclude and produce an approximate solution. They are preferred in recent engineering optimization problem analysis due to their advantages such as the need for derivative information, the ease of adapting to integer programming, the ability to conclude both discrete and continuous solution sets. Because the cutting process includes nonlinear terms as physical processes, conventional optimization methods fail to solve. Under these conditions, Genetic Algorithm (GA), Differential Evolution (DE), Nelder-Mead (NM), Ant Colony Optimization (ACO), Memetic Algorithms (MA), Particle Swarm Optimization (PSO) and Simulated Annealing (SA) methods such as stochastic optimization methods are suitable.

In this study, the optimization process of surface roughness value was carried out using Random Search (RS), Differential Evolution (DE), Nelder-Mead (NM) and Simulated Annealing (SA) methods.

5.1 Single-Objective Optimization

Single-objective optimization is applied to single objective functions to minimize or maximize. This optimization approach includes the limits of design variables, constraints and the limits of constraints. The problems solved by the single-purpose optimization approach are expressed as follows.

The minimization $f(x_1, x_2, \dots, x_n)$,

Such that;

$$h_1(x_1, x_2, \dots, x_n) \geq 0 \quad i = 1, 2, \dots, r$$

$$g_1(x_1, x_2, \dots, x_n) = 0 \quad j = 1, 2, \dots, m$$

$$x^L \leq (x_1, x_2, \dots, x_n) \leq x^u$$

where f is the objective function, x_1, x_2, x_3 etc. design variables, h and g are constraints.

5.2 Multi-Objective Optimization

A multi-objective optimization problem is expressed as;

The minimization $f_1(x_1, x_2, \dots, x_n), f_2(x_1, x_2, \dots, x_n), \dots, f_t(x_1, x_2, \dots, x_n)$

Such that;

$$h_1(x_1, x_2, \dots, x_n) \geq 0 \quad i = 1, 2, \dots, r$$

$$g_1(x_1, x_2, \dots, x_n) = 0 \quad j = 1, 2, \dots, m$$

$$x^L \leq (x_1, x_2, \dots, x_n) \leq x^u$$

where f_1, f_2, \dots, f_t functions are functions to be minimized or maximized.

5.3 Stochastic Optimization Algorithms

In this study DE, NM, RS and SA methods have been used for the optimum minimum surface roughness value and the steps of the algorithms are briefly explained in the following subsections.

The problem was solved in the software program Wolfram Mathematica. NMinimize code has been used at default settings with 1000 iterations.

5.3.1 Nelder-Mead Method

The Nelder-Mead algorithm is a traditional local search method. It was designed primarily by Nelder and Mead (1965) for an unconstrained optimization problem. Nelder-Mead method has not been designed for constrained problems. However, in this study, a modified version of the Nelder-Mead algorithm which solves the optimization problems containing non-linear constraints, mixed integer and continuous design variables has been used. Although Nelder-Mead is not a global optimization algorithm, it is very good for problems that do not have too much local minimum in practical use. The flowchart of the Nelder-Mead algorithm is shown in Figure 5.1 [38].

5.3.2 Random Search Method

The Random Search method, also known as the Monte-Carlo method, is a stochastic-based algorithm that is quite different from the deterministic methods of Branch and Bound, Interval Analysis and Tunneling. In the stochastic process, there are a number of standard techniques and programs based on the random number generator. The values obtained should be scaled and transformed to provide proximity to any desired distribution. The most important advantage of the Random Search algorithm is its ability to reach the general optimum for non-convex, differentiable purpose functions including continuous and discrete areas. Another advantage of the RS method is that it is relatively easy to implement in complex problems. Generally, RS algorithms are known to be "strong" and perform well because of the rapid results for poorly structured global optimization problems. The flowchart of the Random Search algorithm is shown in Figure 5.2 [38].

5.3.3 Simulated Annealing Method

One of the most popular random search methods is Simulated Annealing (SA). This method is based on the physical process of the annealing of a metal, which is heated to high temperature and allowed to cool slowly. The melting process ensures that the atomic structure of the material moves to a lower energy state and thus becomes a hard material.

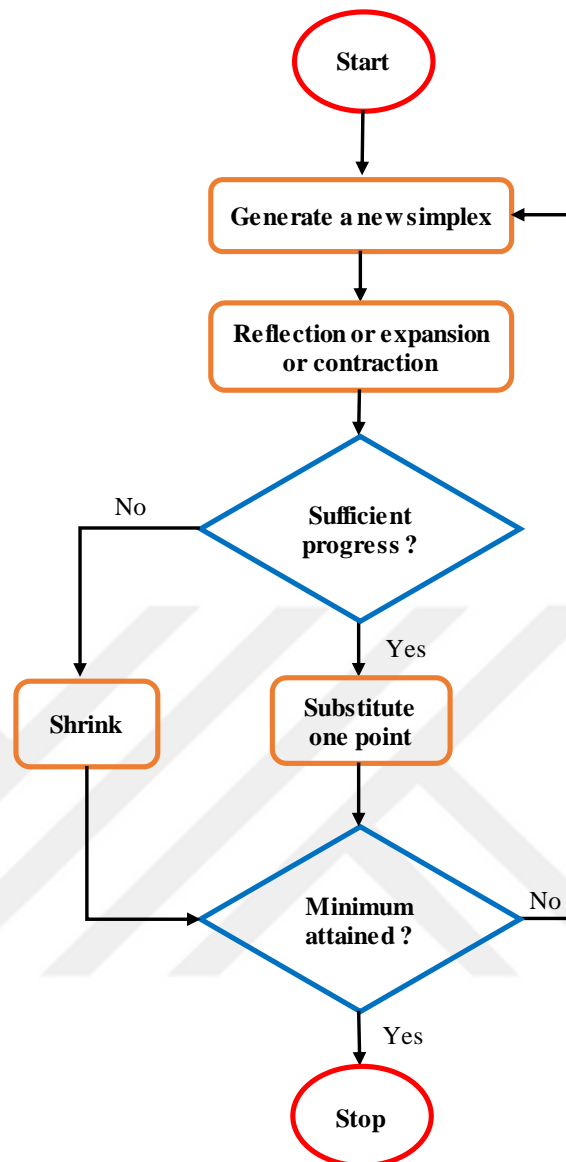

Figure 5.1 The flowchart of Nelder-Mead optimization algorithm [38]

In terms of optimization, the SA algorithm allows the transaction structure to move away from a local minimum and to discover and locate a better global optimal point. The biggest advantage of SA is that it makes it possible to solve various optimization problems such as continuous, discrete or mixed integers. The flowchart of the Simulated Annealing algorithm is shown in Figure 5.3.

5.3.4 Differential Evolution Method

The Differential Evolution (DE) algorithm is a branch of evolutionary programming performed by Price and Storn [39].

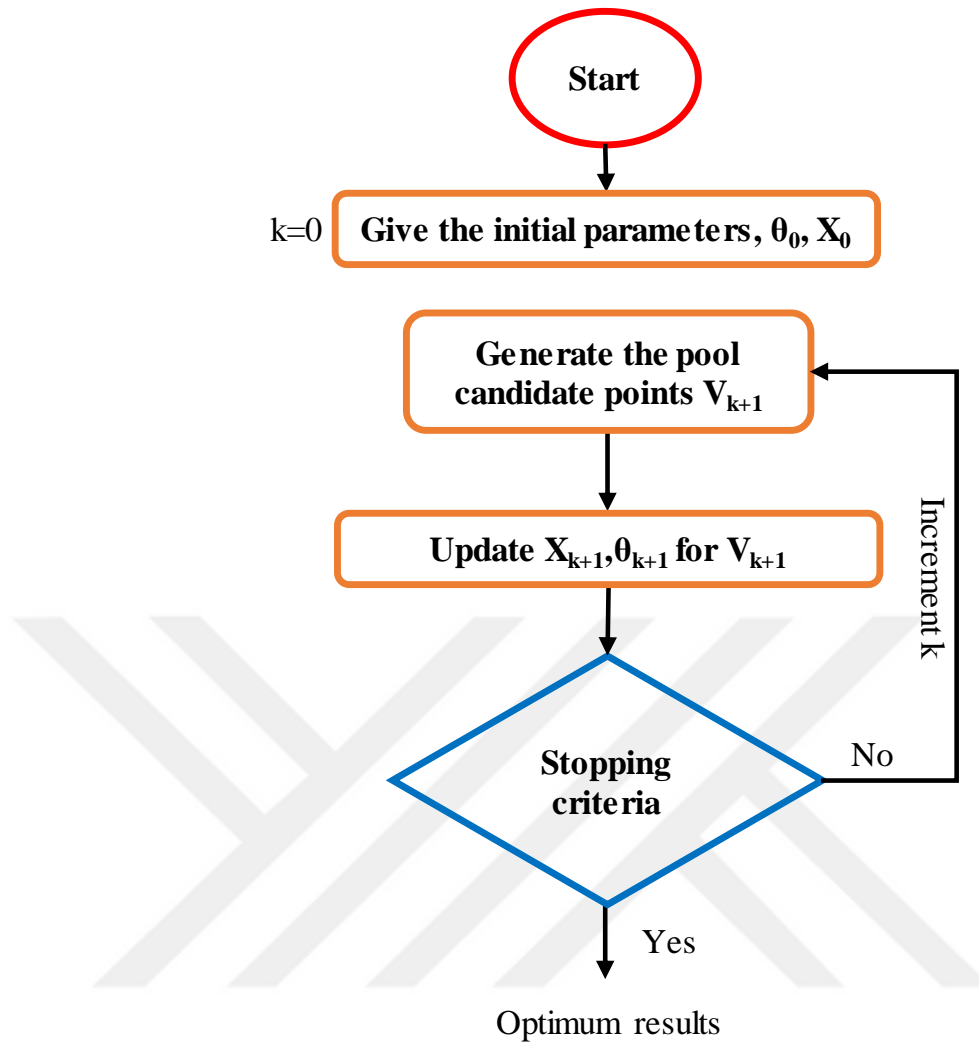

Figure 5.2 The flowchart of Random Search optimization algorithm [38]

The value of each variable in DE is represented by the actual number. The advantages of DE are simple structure, easy to use, fast and robust. DE is one of the best genetic type algorithms to solve problems with real-valued variables. DE has been used in a variety of science and engineering applications to provide solutions to almost all problems that cannot be solved without resorting to expert knowledge or complex design algorithms. DE uses the conversion as a search mechanism and redirects the search to possible regions in the applicable area. The flowchart of the Differential Evolution algorithm is shown in Figure 5.4.

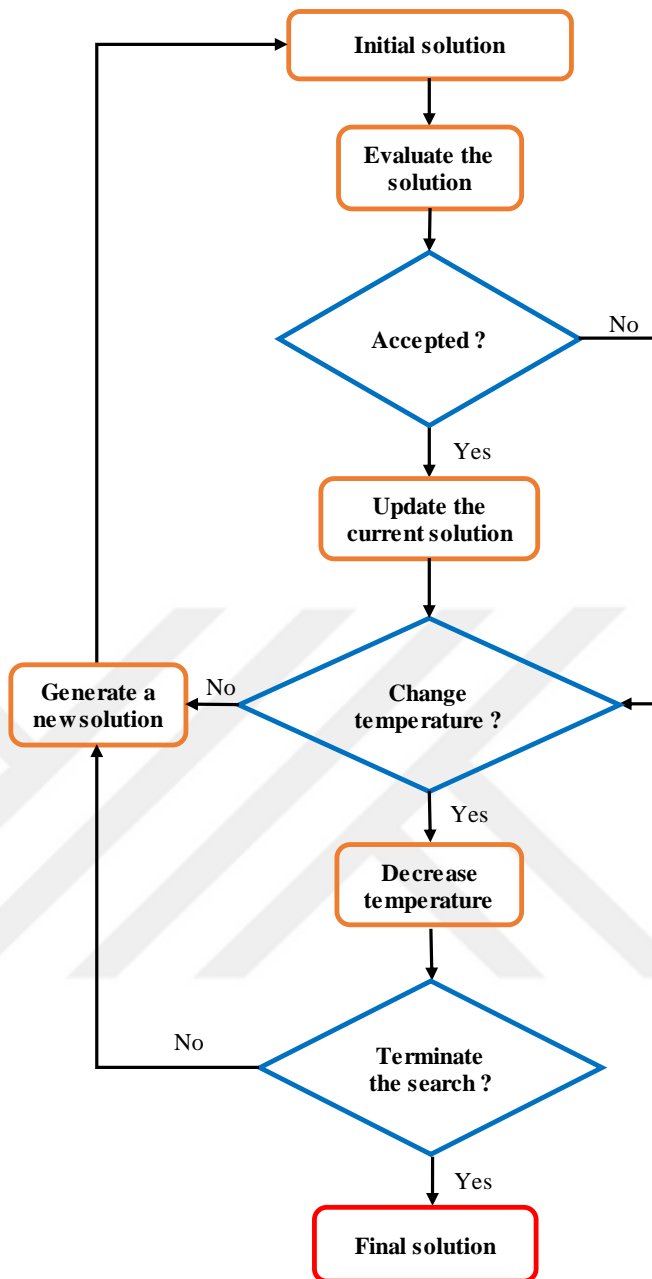

Figure 5.3 The flowchart of Simulated Annealing optimization algorithm [38]

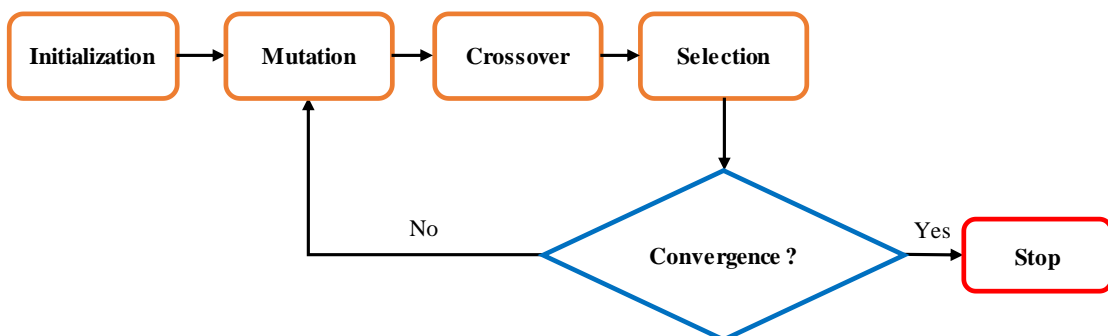

Figure 5.4 The flowchart of Differential Evolution optimization algorithm [38]

CHAPTER 6

RESULTS AND DISCUSSION

6.1 Problem Statement

Minimization of surface roughness is critical for some manufacturing process in industry because some applications require a better surface roughness to avoid premature failure from surface. Accordingly, the aim of the thesis is to obtain the optimum average surface roughness value for three different machining parameters which are spindle speed, feed rate and depth of cut. Surface roughness optimization based on the regression models developed to correlate the machine parameters were determined by four different search methods.

In the solution of optimization problems, sometimes it may be difficult to find the optimum point for a problem, even without restrictions, and therefore the methods used may fail. It is often useful to optimize the function several times under different initial conditions and obtain the best of results.

The mathematical representation of the optimization problem for this study can be stated as;

Minimize: Average surface roughness, $\mathbf{R}_a = \mathbf{R}_a(x_1, x_2, x_3)$

Subjected to Constraints: $1000 \leq n \leq 2000$,

$$1 \leq a \leq 3,$$

$$50 \leq f \leq 100$$

$$\{n, a, f\} \in \text{integers}$$

where \mathbf{R}_a is the objective function, x_1, x_2, x_3 being design variables representing n, a , and f , respectively.

6.2 Evaluation of Regression and Optimization Results

Three inputs have different restrictions and there are some limitations of the machine. For this reason, it is necessary to determine the values that the machine cannot realize as a constraint.

All three input values should be considered as an integer, as an optimization constraint. In addition, lower and upper limits are one of the major constraints of optimization. In this way, the mathematical model which has been developed for optimization will help in predicting the surface roughness parameters and adjusting the process parameters at optimum values to achieve the desired surface quality with high reproducibility and decreasing surface roughness.

As mentioned previously in chapter 3, first the coefficient of determination of all seven mathematical models have been performed. In order to examine whether the number of data is sufficient, the numerical value of the adjusted coefficient of determination has been investigated. It has been observed that the coefficient of determination and adjusted coefficient of determination values were acceptable. This indicates that the data are sufficient.

Testing of mathematical models have been performed by training and testing technique of regression analysis by dividing eighteen data for training and testing. Stability analysis was performed as another method of testing the regression equation. Mathematical models have been evaluated how they react in reduced and increased input values within twenty percent range.

Graphics have been used to evaluate stability. The worst graphics are second and third mathematical models. In the second mathematical model, it is observed that at least one of the trigonometric terms goes towards infinity in trigonometric function. In second mathematical model. Because the third model has been rational, it has been observed that the model did not respond to different points due to the coefficients of terms. Although the input values changed in the first, fourth and fifth mathematical models, it has been observed that the output have not been changed. This indicates that the mathematical models cannot respond to different input values. The high value of coefficient of determination of the model represent that the coefficients of terms are well-arranged for only eighteen data. As a result, the sixth model was found to be the most suitable model.

According to the sixth model, the effects of three different inputs on the surface roughness values have been shown in the Figure 6.1-6.3.

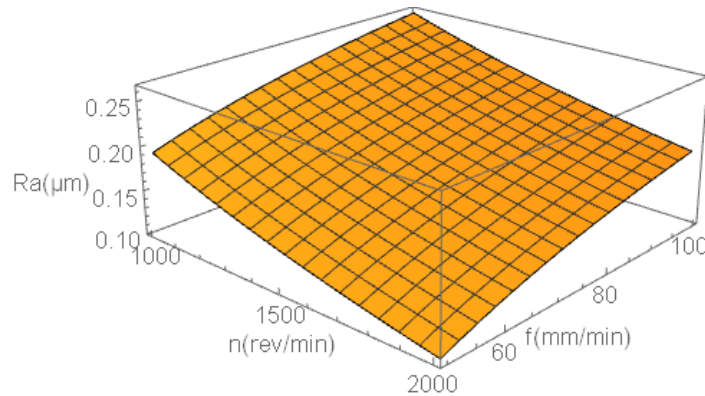

Figure 6.1 The effect of spindle speed (n) and feed-rate (f) for 3 mm depth of cut

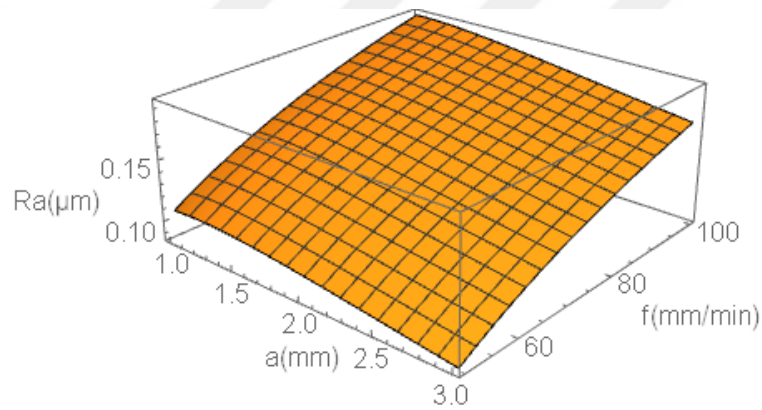

Figure 6.2 The effect of depth of cut (a) and feed-rate (f) for 2000 rev/min spindle speed

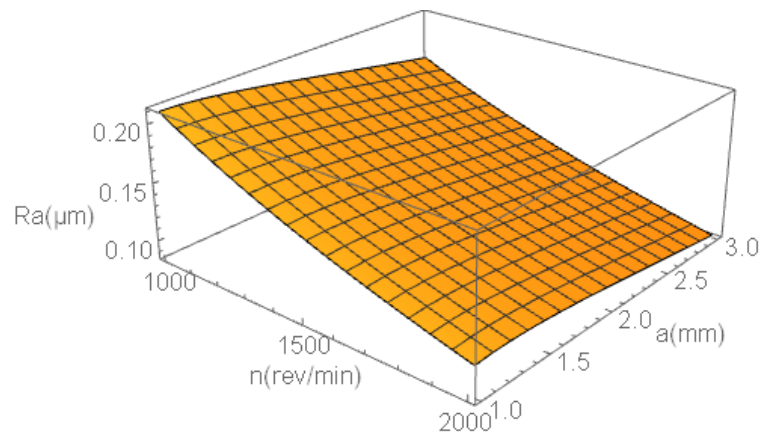

Figure 6.3 The effect of spindle speed (n) and depth of cut (a) for 50 mm/min feed-rate

Single objective optimization has been selected with number of constraints; spindle speed of milling machine has been asked to be higher or equal than 1000 revolution per minute and lower or equal than 2000 revolution per minute, depth of cut

has been asked to be chosen integers and range between 1 and 3 millimeters, feed has been asked to be chosen integers and range between 50 and 100 millimeters per minute. Consequently, if not to interfere with the machine and the environment, the optimum values for cutting parameters spindle speed, depth of cut and feed rate are obtained as 2000 rev/min, 3 mm and 50 mm/min, respectively. The optimum average surface roughness value with these input values have been acquired as 0.086 micrometers. In optimization, four different algorithms have been run 50 times and the identical results have been achieved for optimum average surface roughness value. This outcome indicates that each method used in this study is reliable with Model 6 to have optimum solution.

The effect of three different inputs on the average surface roughness is shown in the Figure 6.4. As shown in the figure, the effect of spindle speed and feed on surface roughness is greater than the depth of cut. This result, increase in average surface roughness, can be seen with the change from green to orange.

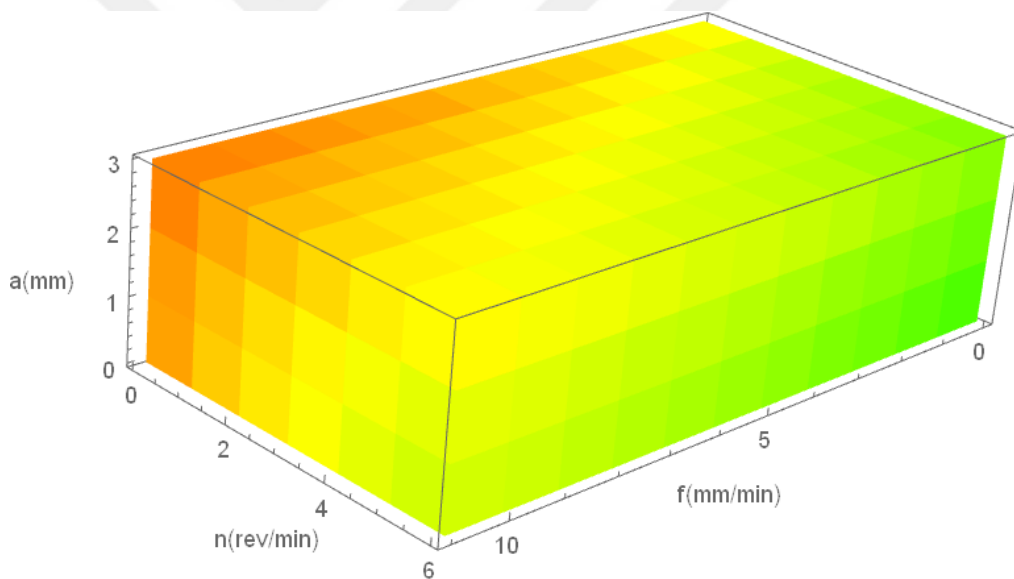

Figure 6.4 The effect of 3 different inputs on average surface roughness

After first set of experiment, the second set of experiment has been made for the validation of the study. When the experimental results were compared, it was estimated that the Model 6 has an average prediction error of 3.29 %, whereas the values in the N. Liu study were estimated at 4.11% as seen in Table 6.1. In this table, $R_{a_{exp}}$ represents the experimental average surface roughness values, $R_{a_{predicted}}^*$ represents the predicted R_a values of N. Liu study and ϵ^* represents the prediction error of N. Liu study, R_{a_6}

represents the predicted R_a values of Model 6 and ϵ_6 represents the prediction error of Model 6 [32].

Table 6.1 Comparison of experimental and predicted results of Model 6 [32]

Number of Experiment	n (rpm)	a (mm)	f (mm/min)	$R_{a_{exp}}$ (μm)	$R_{a_{predicted}}^*$ (μm)	ϵ^*	R_{a_6} (μm)	ϵ_6
1	2000	1	50	0.111	0.115	3.478	0.109	1.802
2	2000	1	75	0.153	0.171	10.526	0.163	6.135
3	2000	1	100	0.197	0.207	4.831	0.196	0.508
4	2000	2	50	0.095	0.105	9.524	0.103	7.767
5	2000	2	75	0.158	0.155	1.899	0.153	3.165
6	2000	2	100	0.19	0.184	3.158	0.185	2.632
7	2000	3	50	0.081	0.083	2.410	0.086	5.814
8	2000	3	75	0.136	0.136	0.000	0.136	0.000
9	2000	3	100	0.171	0.173	1.156	0.168	1.754
Average						4.11		3.29

Table 6.2 S/N ratio effects as constraint [32]

S/N Ratio (η^*)	n (rpm)	a (mm)	f (mm/min)	R_a (μm)
$\eta^* < 20$	2000	3	50	0.086
$\eta^* < 19$	1767	3	50	0.101
$\eta^* < 18$	1534	3	50	0.118
$\eta^* < 17$	1987	3	79	0.143
$\eta^* < 16$	1748	3	81	0.160
$\eta^* < 15$	1868	3	100	0.175

Another observation in milling process is investigation of the effect of Signal to Noise ratio (S/N) for average surface roughness R_a . Signal-to-noise ratio is the ratio of the power of a signal or meaningful information to the power of background noise or unwanted signal. The signal-to-noise values (η^*) were examined to evaluate the

behaviour of the milling operation. The results showed that the noise increases in the direction of ascending in spindle speed between 1500-2000 rev/min as seen in Table 6.2. In other words, the increase in spindle speed has a positive effect on the system.



CHAPTER 7

CONCLUSION

This thesis has presented a study of the minimization of surface roughness on a milling process using stochastic methods. The surface of workpiece in milling process is subjected to multiple forces and effects. These cause to begin wear on the insert surface. With the developing technology, the precision of the assembled parts increases and therefore requires a narrow machining tolerance. In slot milling process, the tolerances in the surface profiles of the end-mill meet the tolerances of the workpiece. In order to reduce the wear of the surface profile of the insert tip over time and thus to maintain the geometric tolerances, it is required to optimize the cutting parameters.

In this study, analysis and optimum cutting parameters of slot milling process have been performed considering machine constraints. Totally seven mathematical models have been investigated for average surface roughness by using regression analysis. Five of the developed mathematical models were selected as rational. Another two mathematical models have been considered as nonrational. The coefficients of seven mathematical equations were determined using Wolfram Mathematica Commercial Software program. After investigating the reliability of the model, it is decided to use Model 6 for average surface roughness as an objective function in optimization. Spindle speed, depth of cut and feed have been considered as design variables. Four different stochastic search algorithms which are Random Search, Simulated Annealing, Nelder-Mead and Differential Evolution have been used in optimization process.

According to the results obtained, it can be concluded that minimum feed (50 mm/min), maximum spindle speed(2000 rev/min) and maximum depth of cut(3 mm) are the optimum values to minimize the average surface roughness(0.086 μm) for slot milling process with end-mill machining the material Al-7075.

As a future study, the machine capability and the environmental effects such as coolant system can be studied. This gives a meaningful information if a different material or cutting tool is used.



REFERENCES

- [1] Childs, T., Maekawa, K., Obikawa, T., Yamane, Yasuo., *Metal Machining Theory and Applications*, (2000), p.1-9.
- [2] Kalpakjian, S., Schmid, S.R., *Manufacturing Engineering and Technology*, Seventh Edition, (2014), p.676-679.
- [3] Nalbant, M., Gökkaya, H., and Sur, G., *Application of Taguchi Method in the Optimization of Cutting Parameters For Surface Roughness in Turning*, (2006).
- [4] Yousuff, C. M., Danish, M., Ho, E. T. W., Basha, I. H. K., and Hamid, N. H. B., *Study on the Optimum Cutting Parameters of an Aluminum Mold for Effective Bonding Strength of a PDMS Microfluidic Device*, (2017).
- [5] Eşme, U. and Serin, H., *A Study For The Optimization of Cutting Forces Based on the Taguchi Method*, (2007).
- [6] Durakbasa, M. N., Akdogan, A., Vanli A. S. and Bulutsuz, A. G., *Optimization of End Milling Parameters and Determination of The Effects of Edge Profile for High Surface Quality of AISI H13*, (2014).
- [7] Özel, T. and Karpat, Y., *Predictive Modeling of Surface Roughness and Tool Wear in Hard Turning Using Regression and Neural Networks*, (2004)
- [8] Kübler, F., Böhner, J. and Steinhilper, R., *Resource Efficiency Optimization of Manufacturing Processes Using Evolutionary Computation: A Turning Case*, (2015).
- [9] Yildiz, A.R., *Optimization of Cutting Parameters in Multi-pass Turning Using Artificial Bee Colony-based Approach*, (2013).
- [10] Zuperl, U., and Cus, F., *Optimization of Cutting Conditions During Cutting by Using Neural Networks*, (2003).
- [11] Zhang, X., Guo, G., Chen, M., Rong, B., Han, B., Liu, G., and Zhang, Y., *Cutting Parameters Optimization by Fuzzy Synthetic Evaluation and BP Neural Network in Milling Aluminum Alloy*, (2010).
- [12] Savaskan, M., Taptik, Y., and Urgan, M., *Deney Tasarımı Yöntemi ile Matkap Uçlarında Performans Optimizasyonu*, (2004).
- [13] Asilturk, I., Akkus, H., *Determining the Effect of Cutting Parameters on Surface Roughness in Hard Turning Using the Taguchi Method*, (2011).
- [14] Debnath, S., Reddy, M. M., and Yi, Q. S., *Influence of Cutting Fluid Conditions and Cutting Parameters on Surface Roughness and Tool Wear in Turning Process Using Taguchi Method*, (2015).
- [15] Yildiz, A., *Hybrid Taguchi-differential Evolution Algorithm for Optimization of Multi-pass Turning Operations*, (2012).

- [16] Wang, Z. G., Wong, Y. S., and Rahman, M., Optimization of Multi-pass Milling Using Genetic Algorithm and Genetic Simulated Annealing, (2004).
- [17] Gopal, P. M., and Prakash, K. S., Minimization of Cutting Force, Temperature and Surface Roughness through GRA, TOPSIS and Taguchi Techniques in End Milling of Mg Hybrid MMC, (2017).
- [18] Subramanian, M., Sakthivel, M., Sooryaprakash, K., and Sudhakaran, R., Optimization of Cutting Parameters for Cutting Force in Shoulder Milling of Al7075-T6 Using Response Surface Methodology and Genetic Algorithm, (2013).
- [19] Rao, S. S., Engineering Optimization Theory and Practice, 4th Edition, (2009), p.35-36.
- [20] Groover, M. P., Fundamentals of Modern Manufacturing Materials, Processes, and Systems, 4th Edition, (2010), p486-524.
- [21] Davim, J. P., Modern Machining Technology, (2011), p213-217.
- [22] Courtesy of Sandvik Coromant, <https://www.sandvik.coromant.com>
- [23] Dolinsek, S., Kopac, J., Mechanism and Types of Tool Wear Particularities in Advanced Cutting Materials, (2006).
- [24] Dolinsek, S., Sustarsic, B., Kopac, J., Wear Mechanisms of Cutting Tools in High Speed Cutting Processes, (2001), p351.
- [25] Mitutoyo Corporation, <https://www.mitutoyo.com>
- [26] Taylor Hobson Ltd, <https://www.taylor-hobson.com>
- [27] Kuljanic, E., and Sortino, M., TWEM, A Method Based on Cutting Forces – Monitoring Tool Wear in Face Milling, (2004).
- [28] Yildiz, S., and Unsacar, F., A Dynamometer Design For Measurement The Cutting Forces on Turning, (2005).
- [29] Stigler, S. M., Gauss and The Invention of Least Squares, (1981)
- [30] Galton, F., Regression Towards Mediocrity in Hereditary Stature,(2012). The Journal of the Anthropological Institute of Great Britain and Ireland, Vol. 15(1886), pp. 246-263.
- [31] Reinsch, C. H., Smoothing by Spline Functions (1967) Numerische Mathematik, Vol. 10, pp177-183.
- [32] Liu, N., Wang, S. B., Zhang, Y. F. and Lu, W. F., A Novel Approach to Predicting Surface Roughness Based on Specific Cutting Energy Consumption When Slot Milling Al-7075, (2016).
- [33] Devore, J. L., Probability and Statistics for Engineering and The Sciences, Eighth Edition, (2012), p484-487.
- [34] Mendenhall, W., A second Course in Statistics – Regression Analysis, 7th Edition, (2012), p121-125,p182.

- [35] Alexander, D. L. J., Tropsha, A. and Winkler, D. A., Beware of R^2 : Simple, Unambiguous Assessment of the Prediction Accuracy of QSAR and QSPR Models, (2015).
- [36] Garnet, J. B., Bounded Analytic Functions, 2007.
- [37] Silva, S. P., Filho, S. L. M. R., and Brandao, L. C., Particle Swarm Optimization For Achieving the Minimum Profile Error in Honing Process, (2014).
- [38] Ozturk S., Aydin L., and Celik, E., A Comprehensive Study on Slicing Processes Optimization of Silicon Ingot for Photovoltaic Applicatins, (2017).
- [39] Storn, R., and Price, K., Differential Evolution – A simple and Efficient Adaptive Scheme for Global Optimization Over Continuous Spaces, (1996).

