

**DESIGN AND SYNTHESIS OF PHOSPHINE BASED
FLUORESCENT PROBES FOR REACTIVE
OXYGEN SPECIES**

**A Thesis Submitted to
the Graduate School of Engineering and Sciences of
İzmir Institute of Technology
in Partial Fulfillment of the Requirements for the Degree of
MASTER OF SCIENCE
in Chemistry**

**by
Canan ÜÇÜNCÜ**

December 2018

İZMİR

We approve the thesis of **Canan ÜÇÜNCÜ**

Examining Committee Members:

Assoc. Prof. Dr. Mustafa EMRULLAHOĞLU
Department of Chemistry, İzmir Institute of Technology

Assoc. Prof. Dr. Sinan BALCI
Department of Photonics, İzmir Institute of Technology

Asst. Prof. Dr. Nesrin HORZUM POLAT
Department of Science and Mathematics, İzmir Katip Çelebi University

27 December 2018

Assoc. Prof. Dr. Mustafa EMRULLAHOĞLU
Supervisor, Department of Chemistry,
İzmir Institute of Technology

Prof. Dr. Ahmet Emin EROĞLU
Head of the Department of Chemistry

Prof. Dr. Aysun SOFUOĞLU
Dean of the Graduate School of
Engineering and Science

ACKNOWLEDGEMENTS

I would like to thank people who guided and supported me throughout my work. First of all, I would like to thank my supervisor Mustafa Emrulloğlu for his endless motivation, understanding, patience, courage and the opportunity to work in his laboratory. Being a part of the Emrulloğlu working group was a delightful, colourful and memorable experience for me.

I would also like to thank the Emrulloğlu research group members. I am especially grateful to Muhammed who is my mentor, supporter, colleague, friend and brother, for his support, understanding, help, patience and faith in me. I am very honoured to be in the same research group as him and to work together.

I would also like to thank Erman Karakuş for all his help, teaching and support. I would also like to thank Suay Datar, Melike Sayar and Merve Çevik for their sincere help during my studies and I am happy to share the same laboratory. I want to thank my friends, Devrim Bulsoy, Beraat Umur Kaya, Emre Karaburun, Ezgi Vural and Begüm Tokgöz, who I am very happy to recognize and work with.

I am especially grateful to my family, to my mother Fatma Üçüncü, to my father Osman Nuri Üçüncü, to my sisters Yeliz Üçüncü, Yasemin Üçüncü and Halise Üçüncü, to my brother Muhammad Üçüncü for their endless support, trust, beliefs.

In addition, I would like to special thank to the head of the library Gültekin Gürdal, the chemistry department lecturers, research assistants and all my friends.

Finally I am grateful to my best friend Burçin Köksalan for being a great life coach and for her wonderful friendship.

ABSTRACT

DESIGN AND SYNTHESIS OF PHOSPHINE BASED FLUORESCENT PROBES FOR REACTIVE OXYGEN SPECIES

Hypochlorous acid is a cleansing agent known as bleach in daily life. Apart from the household chemicals feature, HOCl plays an active role in the defence system of living cells. It is an important reactive oxygen species that exhibits anti-microbial properties against invaders. However, the increase in the amount of cells in the cell due to oxidative stress causes serious damage to the structure and function of the organism and can cause fatal diseases.

Determination of reactive oxygen species in the cell is of great importance. Although different detection methods are used for this purpose, fluorescent sensors are preferred for their precision, easy preparation, high resolution, and quick response.

In this study, a "turn on" probe has been designed to detect HOCl based on these reasons. Anthracene dye has been found to be non-fluorescent due to PET when derivatized with phosphorus. In the presence of HOCl, it was determined that the phosphorus was oxidized, inhibiting PET and causing fluorescent radiation. The aim of this thesis is to examine the spectroscopic analysis of the probe which is developed as sensitive to HOCl in various ways and to display the presence of HOCl in the living cell.

ÖZET

REAKTİF OKSİJEN TÜRLERİ İÇİN FOSFEN BAZLI FLORESAN PROBLARIN TASARIMI VE SENTEZİ

Hipokloröz asit günlük yaşamda çamaşır suyu olarak bilinen bir temizlik maddesidir. Ev kimyasalları özelliği dışında HOCl canlı hücrelerin savunma sisteminde etkin bir rol oynamaktadır. İstilacılara karşı anti-mikrobiyal özelliği sergileyen önemli bir reaktif oksijen türüdür. Ancak oksidatif stresten dolayı hücre içindeki miktarının artışı organizmanın yapısına ve fonksiyonlarına ciddi zararlar vermektedir ve ölümcül hastalıklara neden olabilmektedir.

Hücre içindeki reaktif oksijen türlerini tayin etmek büyük bir önem taşımaktadır. Bunun için farklı algılama metodları olsa da floresan algıyıcılar hassas olması, kolay hazırlanması, yüksek çözünürlükte olması, hızlı cevap vermesi gibi açılardan tercih edilmektedir.

Bu çalışmada, bu sebepler baz alınarak HOCl'yi tespit etmek amacıyla "turn on" bir sensör dizayn edilmiş geliştirilmiştir. Antrasen boyası fosfor ile türevlendirildiğinde PET'ten dolayı floresan özelliği sergilemediği görülmüştür. HOCl varlığında ise fosforun oksitlenerek, PET'i engellediği ve floresan ışımaya neden olduğu tespit edilmiştir. Bu tezin amacı HOCl'ye duyarlı olarak geliştirilen algılayıcının spektroskopik analizlerin çeşitli yollarla incelenmesi ve canlı hücre içindeki HOCl varlığının görüntülenmesidir.

TABLE OF CONTENT

LIST OF FIGURES	vii
ABBREVIATIONS	xii
CHAPTER 1. INTRODUCTION	1
1.1. Reactive Oxygen Species	1
1.1.1. Production of ROS.....	1
1.1.2. Source of ROS	2
1.1.3. Oxidative Stress	5
1.1.4. Toxicity of ROS.....	6
1.2. Hypochlorous Acid (HOCl)	9
1.2.1. Biological Action of HOCl.....	9
1.2.2. Cytotoxicity of ROS	10
1.3. Detection Method	11
1.3.1. Photoinduced Electron Transfer (PET)	11
1.4. Fluorescent Probes	13
1.5. Literature Works	14
CHAPTER 2. EXPERIMENTAL STUDY	22
2.1. General Method.....	22
2.2. Synthetic Methods.....	22
2.1.1. Synthesis of 9-bromoanthracene	23
2.1.2. Synthesis of (anthracene-9-ylethynyl)trimethylsilane.....	23
2.1.3. Synthesis of 9-ethynylanthracene	24
2.1.4. Synthesis of (anthracen-9-ylethynyl)diphenylphosphine	24
2.3. Determination of Detection Limit	25
CHAPTER 3. RESULT & DISCUSSION	26
3.1. Spectroscopic Analysis	27
3.1.1. Solvent Determination Study.....	27
3.1.2. Water Content Screening Study	27

3.1.3. Determination of pH Study.....	28
3.1.4. Time Profile Study.....	29
3.1.5. Fluorescence Titration Study.....	29
3.1.6. Absorbance	31
3.1.7. Selectivity and Interference Study.....	31
3.1.8. Metal Scanning Study.....	34
3.2. Cell Studying.....	34
CHAPTER 4. CONCLUSION	36
REFERENCES.....	37
APENDICES	42
APPENDIX A. ¹H NMR, ¹³C AND ³¹P NMR SPECTRA OF COMPOUNDS	42
APPENDIX B. MASS SPECTRA OF COMPOUNDS	48

LIST OF FIGURES

Figure 1.1. Physiological ROS homeostasis network.....	3
Figure 1.2. Diseases associated with increased ROS.....	8
Figure 1.3. Representation of PET mechanism. A) “off” state B) “on” state.....	12
Figure 1.4. Representation of molecular orbital diagrams of fluorophores and receptor.	13
Figure 1.5. Demonstration of o-dearylation of HPF and APF with hROS.....	14
Figure 1.6. Sensing representation of probe and HOCl.....	15
Figure 1.7. Demonstration of sensing mechanism.....	16
Figure 1.8. Interaction of probe with ClO ⁻	17
Figure 1.9. Representation of sensing mechanism.....	18
Figure 1.10. Sensing mechanism of probe and ClO ⁻	19
Figure 1.11. Sensing mechanism of BTCBA based on ICT mechanism.....	19
Figure 1.12. Interaction of probe and HOCl.....	20
Figure 1.13. The strategy of photocontrollable fluorogenic probe in the detection of ClO ⁻ near membrane.....	21
Figure 2.1. The pathway of synthesis of ANT-DPP	22
Figure 2.2. 9-bromoanthracene.....	23
Figure 2.3. (anthracen-9-ylethynyl)trimethylsilane.....	24
Figure 2.4. 9-ethynylanthracene.....	24
Figure 2.5. (anthracen-9-ylethynyl)diphenylphosphine.....	25
Figure 3.1. Reaction-based detection of HOCl.....	26
Figure 3.2. Solvent screening of ANT-DPP (10μM) towards addition of HOCl (100μM), (λ _{ex} : 380nm, λ _{em} : 460nm, 25°C).....	27
Figure 3.3. Water content solvent system, ANT-DPP (10μM) towards addition of HOCl (100μM), (λ _{ex} : 380nm, λ _{em} : 460nm, 25°C).....	28
Figure 3.4. pH screening of ANT-DPP (10μM) towards addition of HOCl (100μM) in	

CH ₃ CN/HEPES (1:1, v:v), (λ_{ex} : 380nm, λ_{em} : 460nm, 25°C).....	29
Figure 3.5. Time profile of ANT-DPP (10 μ M) towards addition of HOCl (1 μ M, 3 μ M, 5 μ M) in CH ₃ CN/HEPES (1:1, v:v), (λ_{ex} : 380nm, λ_{em} : 460nm, 25°C).....	30
Figure 3.6. Fluorescence titration of ANT-DPP (10 μ M) upon addition of HOCl (from 0 μ M to 200 μ M) in CH ₃ CN/HEPES (1:1, v:v), (λ_{ex} : 380nm, λ_{em} : 460nm, 25°C)	30
Figure 3.7. Graph used for calculation of detection limit	31
Figure 3.8. Absorbance spectra of ANT-DPP (10 μ M) and ANT- DPP + HOCl (100 μ M) in CH ₃ CN/HEPES (1:1, v:v).....	32
Figure 3.9. Fluorescence titration of ANT-DPP (10 μ M) upon addition of other ROS/RNS (200 μ M) in CH ₃ CN/HEPES (1:1, v:v), (λ_{ex} : 380nm, λ_{em} : 460nm, 25°C).....	33
Figure 3.10. Fluorescence titration of ANT-DPP (10 μ M) upon addition of other ROS/anions (200 μ M) + HOCl (100 μ M) in CH ₃ CN/HEPES (1:1, v:v), (λ_{ex} : 380nm, λ_{em} : 460nm, 25°C).....	33
Figure 3.11. Metal scanning of ANT-DPP (10 μ M) upon addition of other metals (200 μ M) + HOCl (100 μ M) in CH ₃ CN/HEPES (1:1, v:v), (λ_{ex} : 380nm, λ_{em} : 460nm, 25°C).....	34
Figure 3.12. (a) Fluorescence image of human lung adenocarcinoma cells (A549) treated with only ANT-DPP (10 μ M) for 20 min; (b) Bright-field imaging (c) Cells treated with ANT-DPP and HOCl (100 μ M) (d) Merged image of b and c. (λ_{ex} : 380nm).....	35

LIST OF ABBREVIATIONS

A549	Human Lung Adenocarcinoma Cells
Arg	Arginine
Asn	Asparagine
ATP	Adenosine Triphosphate
BODIPY	3,5-Diaryl-4,4-difluoro-4-bora-3a,4a-diaza-s-indacene
CH₃CN	Acetonitrile
Cys	Cysteine
DMF	Dimethyl Formamide
Eq	equivalent
Et₃N	Triethylamine
Gln	Glutamine
GSH	Glutathione
HBr	Hydrogen Bromide
HEPES	2-[4-(2-hydroxyethyl)piperazin-1-yl]ethanesulfonic acid
His	Histamine
HOMO	Highest Occupied Molecular Orbital
ICT	Internal Charge Transfer
LUMO	Lowest Occupied Molecular Orbital
M	Molar
Met	Methionine
Mg	milligram

ml	milliliter
mmol	millimole
MPO	Myeloperoxidase
NADH	Nicotinamide adenine dinucleotide
NADPH	Dihydronicotinamide-adenine dinucleotide phosphate
Nm	Nanometer
NMR	Nuclear Magnetic Resonance
PET	Photoinduced Electron Transfer
RNS	Reactive Nitrogen Species
ROS	Reactive Oxygen Species
SOD	Superoxide Dismutase
THF	Tetrahydrofuran
TLC	Thin Layer Chromatography
TMS-Acetylene	Trimethylsilylacetylene
Trp	Tryptophan
Try	Tyrosine
Pd(PPh₃)₂Cl₂	Bis(triphenylphosphine)palladium(II) dichloride

CHAPTER 1

INTRODUCTION

1.1. Reactive Oxygen Species

1.1.1. Production of ROS

Oxygen is indispensable for the continuity of life and cell activities. Oxygen is responsible for the production of adenosine triphosphate which is essential for various cell functions and reactions. Furthermore, it is indispensable for the respiratory process in terms of regulation and progression of reactions. Respiratory chain occurs in mitochondria which is membrane-enclosed cell structures. Different by-products which are called reactive oxygen species (ROS) and reactive nitrogen species (RNS) can be generated during molecular oxygen reactions such as conversion to water or production of ATP (Bhattacharya, 2015).

ROS defines various free radicals or molecules that derived from molecular oxygen. Molecular oxygen is bi-radical which carries two unpaired electrons in the outer shell. Two single electrons in the chemical bond are not reactive because they have the same spin hence oxygen reacts with only one electron. However, when one of the unpaired electrons changes the spin by excitation, oxygen will become strong oxidant because opposing spins highly reacts with other unpaired electrons. The reduction of oxygen by one electron produces the superoxide anion which is the precursor of some ROS and plays an important role in the oxidative chain reactions. Dismutation of superoxide which generates hydrogen peroxides can occur either spontaneously or catalyse by superoxide dismutase. Hydrogen peroxides may turn into water and hydroxyl radical by reduction (Turrens, 2003).

ROS plays lots of important roles in many biological processes such as induction of transcription factors with gene expression, cellular growth, defence against infections and activation of signal transduction pathways. Mitogen-activated protein kinases are examples of signal transduction molecules activated by reactive oxygen species. ROS molecules have been found to be responsible for the inhibition of protein tyrosine phosphatases, the activation of some redox-sensitive transcription factors and

the module of multiple redox-sensitive intracellular signalling pathways in mammalian cells produced from NADPH oxidase, including modulation of some ion channel functions. As an example, growth factor-mediated responses in endothelial cells (which are important ROS sources due to the various homologs present within these cells) are shown by reactive oxygen species such as superoxide and hydrogen peroxide in angiogenesis-causing endothelial cells. ROS derived from homologs in these cells stimulates various signalling pathways leading to migration and proliferation of endothelial cells. Reactive oxygen derivatives also act as secondary messengers. Secondary messenger functions of ROS are known with various examples of sea urchins, such as ROS increase during fertilization, synthesis of molecules such as thyroxine and prostaglandin, and activation of plant defence genes (Bhattacharya, 2015; Malik et al. 2014).

1.1.2. Source of ROS

There are two main pathways for production of reactive oxygen species which are based on enzymatic and non-enzymatic reactions. In Figure 1, physiologic network of ROS is represented (Hole, Darley and Tonks, 2011). Superoxide is formed by one electron reduction of molecular oxygen and this reaction is taken place by various enzymes like NAD(P)H oxidase and xanthine oxidase (Taniyama and Griendling, 2003). Superoxide dismutase enzyme generates hydrogen peroxides which are the more stable form of reactive oxygen species. Hydrogen peroxide formation occurs by the conversion of H₂O with the help of some enzymes like catalase and glutathione peroxides. Hydrogen peroxides can be reduced by some transition metals (Cu⁺, Fe²⁺) to turn into reactive hydroxyl radical. Also, it can be metabolized by myeloperoxidase enzyme for the formation of HOCl. (Pizzino et al. 2017).

Reactive oxygen species have significant missions in the physiological and pathological processes (Wang, 2016). Briefly, ROS is a constant result of aerobic metabolism which is energy production from carbohydrate, fat or protein by using oxygen. The balance of oxidation-antioxidation is modulated by ROS that is highly important in terms of cell function continuity. Reactive oxygen species are generally produced during mitochondrial electron transport. ROS are important chemicals for the balance of many factors and produced in two ways endogenously and exogenously. Endogenous ROS production mainly occurs in mitochondria during respiration chain,

also cytochrome P450 metabolism, peroxisomes, and inflammatory cell activation generate the ROS (Bhattacharya, 2015). Mitochondria are cell organelle in which energy is converted to ATP.

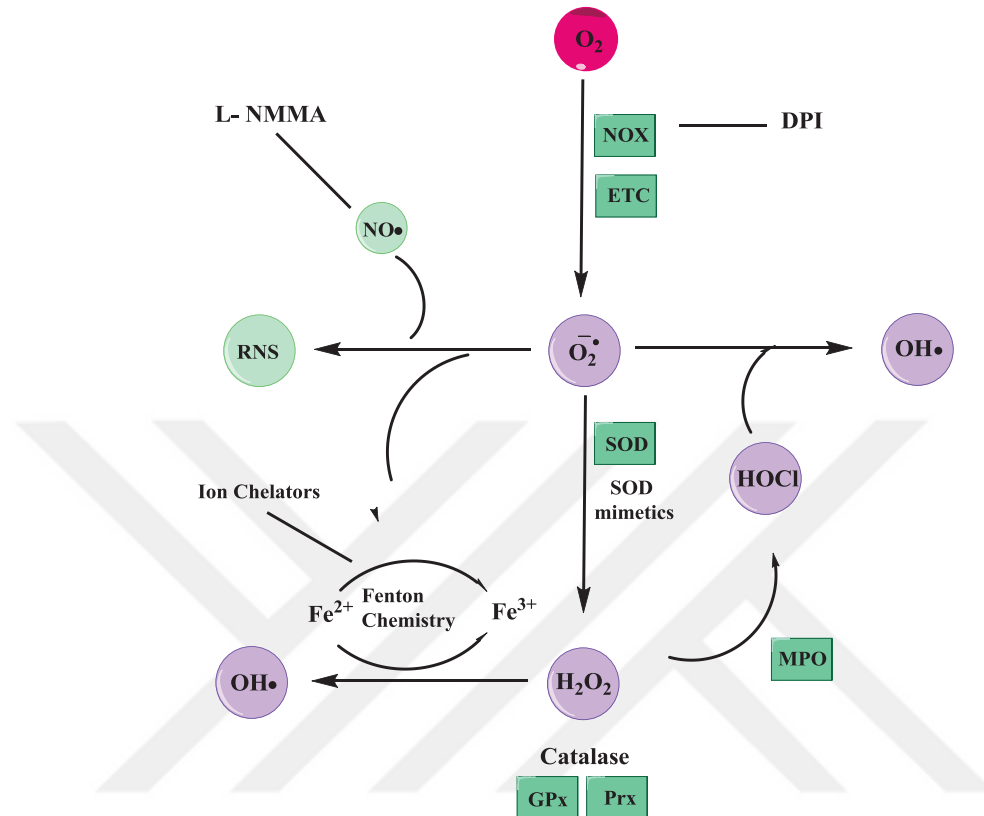

Figure 1.1: Physiological ROS homeostasis Network

(Source: Hole, Darley and Tonks, 2011)

ATP is produced during oxidative phosphorylation in which hydrogen ions flow through the inner mitochondrial membrane by electron transport chain. In the electron transport chain, electrons involve in various oxidation-reduction reactions and interact with proteins. An electron wants to reach molecular oxygen throughout this transportation. Generally, this process produces water by reduction of oxygen whereas some electrons reduce oxygen to superoxide by Complex I and Complex III. Non-reactive superoxide can inactivate some specific enzymes or its protonated form (hydroperoxyl) can trigger the lipid peroxidation.

Besides mitochondrial respiratory chain, ROS are also generated by cytochrome P-450 mixed function oxidases. P-450 cytochromes are proteins that contain heme group, and they are significant for some metabolic factors such as fatty acids, cholesterol, steroids, or bile acids. The enzyme in the body occurs naturally and is

responsible for detoxifications and estranging of undesired materials taken into the biologic system. Cytochrome P-450 catalyses usage of oxygen in biochemical reactions and causes to the production of ROS during the reactions. ROS generation depends on the compound to be involved in the reaction and related cytochrome P-450 protein. CYP2E1 one of the well-known cytochrome P-450 produces ROS in excess if overdose amount of alcohol are taken into the body (Bhattacharya, 2015; Ozougwu, 2016).

In addition to the above examples, oxidative enzymes are responsible for the production of ROS too. These enzymes such as xanthine oxidase behave as a dehydrogenase under normal physiological conditions which helps to the formation of NADH, by removing a proton (hydrogen) from xanthine or hypoxanthine. After the removal process, NAD is protonated and NADH is regenerated. However, when blood flow to the tissue is damaged, xanthine dehydrogenase becomes a new oxidase which generates ROS (Bhattacharya, 2015; Ozougwu, 2016; Pizzino et al., 2017).

ROS are also produced in the immune cells -macrophages and neutrophils- that serve to defend the body against harmful and foreign microorganisms. NADPH oxidase complex which is in charge of production of superoxide radicals and hydrogen peroxide exists in macrophages and neutrophils. ROS production is vital in immune cells for a healthy life. To kill invaders, hydrogen peroxide reacts with chloride inside the cells and produces the hypochlorite. Furthermore, myeloperoxidase (MPO), a peroxidase enzyme exist in neutrophils, generates HOCl from hydrogen peroxide and chloride with the help of heme. The same as pathogen killer HOCl, MPO oxidizes tyrosine to tyrosine radical in the hydrogen peroxide medium. Both produced molecules are used by neutrophils as pathogen killer against invaders.

Considering environmental factors, it can be seen that exogenous factors can be ROS sources as well. Redox-cycling agents such as tobacco, radiation, UV light or some of pesticides, drugs and cancer treatment materials may cause the production of ROS. The treatment materials fight against unwanted cells like tumours. However, during the production of the original product, these materials can show continuous toxicity due to their ability to modify enzymes to unstable intermediates, which reacts with molecular oxygen and generates superoxides. (Bhattacharya, 2015; Ozougwu, 2016).

Exogenous ROS production is resulted from many factors especially exposure to environmental pollutants, daily chemicals, tacrolimus and cyclosporine and like drugs, alcohol, smoked meat and radiation. Defence system tries to degrade or metabolize this kind of factors when taken inside the body. During these processes, free radicals are produced as by-products which destroy the functioning of metabolic functions and cause permanent damage to various diseases and DNA structures.

1.1.3. Oxidative Stress

ROS are of great importance in many aspects of biological systems. Reactive oxygen species are active chemicals during cell functions which include cell growth, differentiation, and homeostasis (Zhang et al., 2015). Oxidative stress defines the excessive amount of reactive oxygen species in the cell. In a cell, transportation of pro-oxidant agents work in harmony and provide the biological activity and the environment required for the living system. Short-term oxidative stress may be good for the cell however long-term situation is harmful and deathly for the living system. Long-term oxidative stress may generate mortal consequences for mammalian such as arthritis, aging, cancer autoimmune disorders, and cardiovascular and neurodegenerative diseases. For examples, oxidative stress is one of the significant reasons for the accumulation of high amount of free calcium or iron ions which are the activator of endonucleases and cause the DNA fragmentation. When the double strand of DNA breaks, the proteins required to repair it are over-secreted and conditions that are inappropriate for system work are generated.

Preservation of this balance within the cell is very important. For instance, when a toxic substance is removed from the body by phagocytosis, the hydroxyl anion and superoxide anion are released to the medium. During this release amount of antioxidants may not be sufficient to protect the cell and cause inflammatory damage known as protein, lipid, and DNA oxidation. Lipid peroxidation, oxidation of lipids, causes oxidative stress in the cell and produces age-related pigments and lipofuscins (Gagné, 2014).

Changes within the cell determine the severity of oxidative stress and their effects on the cell. Short-term oxidative stress can be useful to the cell by taking part in the cell's defence system to kill pathogens. Then, the cell can diminish oxidative stress

and return to its original state. However, in other cases, it may lead to cell apoptosis. Since destructive oxidative stress will cause necrosis in the cell, it is very important to reduce it. The less reactive oxygen species are transformed into harmful radicals by oxidoreduction reactions with transition metals and redox cycle compounds, causing great damage to the cell. Oxidative mediated reactions take place in cell respiration, lipid synthesis, immunity and inflammation, lysosomes, and various biotransformations of compounds for the continuity of living systems. Reactive oxygen species, released into the cell, are neutralized by antioxidants (with reduced thiols and some vitamins) and various enzymes (such as superoxide dismutase, glutathione reductase, peroxidase, catalase) to reduce or eliminate their destructive effects (Gagné, 2014). There are some special conditions in which these enzymes can perform their functions. For example, metal ions for SODs in mammalian cells are needed. Therefore, daily mineral intake is important to reduce the effect of reactive oxygen species and can reduce aging (Ozougwu, 2016). Enzymes -help to remove hydrogen peroxide- are known as catalase and glutathione peroxidase. Catalases are found in small membrane-coated cell components called peroxisome and are iron-containing enzymes. By catalysing a reaction between two hydrogen peroxides, water and oxygen are formed by the reaction, thereby detoxifying hydrogen peroxide in the cell. (Bhattacharya, 2015). In the glutathione peroxidase system, glutathione peroxidase, glutathione reductase enzymes, and cofactors are composed of various components such as monomeric glutathione (GSH) and reduced nicotinamide adenosine dinucleotide phosphate (NADPH). Glutathione peroxidases have an important role in defending the body against invaders as it contains amino acid modified by the addition of selenium metal. Just like lipid peroxidases, they also diminish the amount of ROS inside the cell. GSH, which is a cofactor for the glutathione transferase enzyme, helps in the removal of it from the cell by interacting with specific ROS. (Bhattacharya, 2015; Ozougwu, 2016).

1.1.4. Toxicity of ROS

Oxidative stress has toxic effects on cell viability due to its potential reactivity towards cellular macromolecules which can produce different types of secondary radicals (lipid radicals, sugar and base derivative radicals, amino acid radicals and thiol radicals) (Winternbourn, 2008; Bhattacharya, 2015; Mittler, 2017). The term macromolecules inside the cell involve DNAs, proteins and lipids that carry the

organism's life code. Reactions take place depending on the production site, the nature of the substrate, reactivation mechanisms, and redox conditions. The activity of ROS differs from cell to cell due to the presence of different components. For example, the presence of iron in Fenton reactions affects the formation of the radical and the activity of ROS varies according to the role of this metal (Bhattacharya, 2015; Mittler, 2017). ROS disrupts the three-dimensional structure of proteins, and causes aggregation or cross-linking. Protein oxidation produces aldehydes, ketones, and carbonyl compounds. Also, amino acid residues of proteins are highly sensitive to ROS oxidation (Bhattacharya, 2015). In addition to the effects of protein oxidation, lipid peroxidations also result in the formation of lipid-protein and lipid-DNA inserts that can damage membrane proteins, cross-link membrane changes and cell functions (Aruoma, 1998). The hydroxyl radical, one of the reactive oxygen species, reacts with DNA to form a variety of additions. It disrupts the DNA structure by attacking radical purine and pyrimidine bases. In addition, free radicals in the cell attack the sugar moiety to generate sugar peroxy radicals that cause strand breakage. ROS cause permanent damage to DNA and RNA, and has significant effects on cell death, mutagenesis, carcinogenesis and cell aging (Knight, 1998).

The excessive production of ROS negatively affects the functioning of the biological system. High oxidative stress in the cell disrupts the cell functions and causes many diseases as indicated in Figure 1.2. (Brieger et al., 2012). The increased amount of free radicals and peroxides in the cell damage to macromolecules as well as disturbances in cells in the normal redox state cause toxic effects (Knight, 1998). Considering these situations, it is thought that ROS is one of the main sources of the many diseases that threatens human health and gives long efforts for their treatment.

ROS-induced diseases include cancer, inflammatory diseases, cardiovascular diseases, respiratory diseases, diabetes, male infertility, the aging process neurological diseases (Bhattachary, 2015). The damage caused by ROS and progression of carcinogenesis, and strengthening the severity. Attack of the radicals to the DNA bases leads to miscoding of DNA, mutations in DNA, gene duplications, rearrangement of DNA sequences, and activation of oncogenes that have a destructive effect (Brieger et al., 2012), (Prasad, Gupta and Tyagi, 2017). ROS can cause cancer development by dysregulation. For example, in renal cell carcinoma, hypoxia response genes cannot be appropriately regulated and cause tumour growth, angiogenesis, and metastasis

(Medjkane et al., 2013). Another disease caused by ROS is cardiovascular disease. It contributes to the pathophysiology of hypertension.

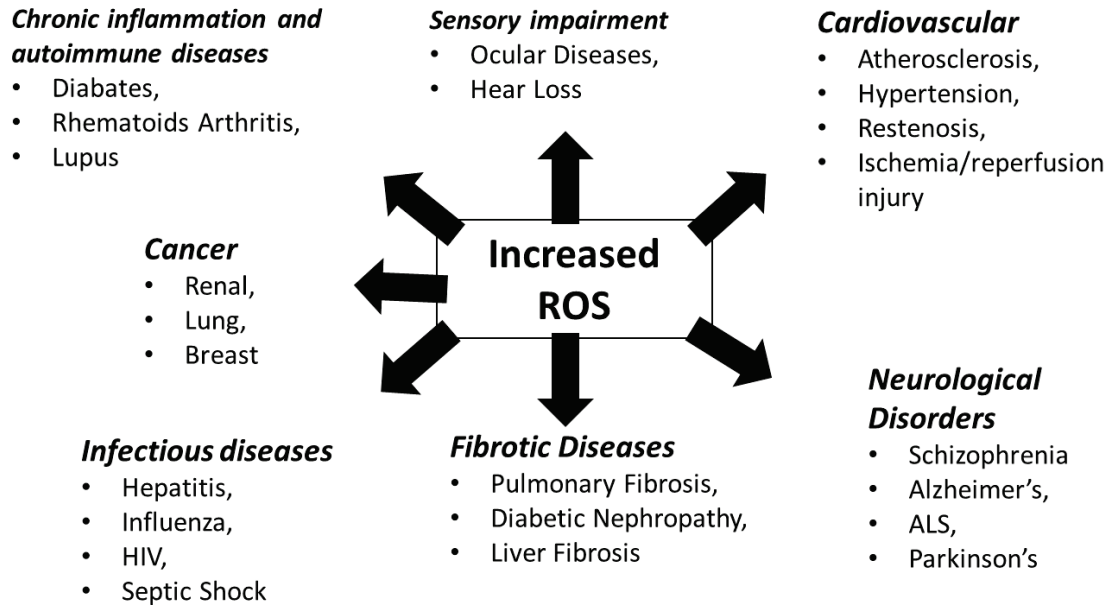

Figure 1.2. Diseases associated with increased ROS

(Source: Brieger et al., 2012)

The bioavailability of the vasodilator nitric oxide decreases with the increase of superoxide. They have important roles in the proliferation and hypertrophy of vascular smooth muscle cells and cause increased vascular resistance (Brieger et al., 2012) ROS plays an important role in the development and progression of neurological diseases. Reactive oxygen species are synthesized in small amounts in some of the brain cells such as astrocytes and neurons and are important for brain activity when they are in low levels. However, increased amounts of ROS causes neurotoxicity to reveal neurological diseases such as Alzheimer's disease, neuroinflammatory, Parkinson's disease (Brieger et al., 2012), (Pizzino et al., 2017). In addition, reactive oxygen species are effective in the progression of degenerative disease, amyotrophic lethal sclerosis (ALS) (Barber, Mead and Shaw, 2006). A chronic inflammatory disease rheumatoid arthritis affects macrophages and activated T cell infiltration, which characterizes the joints and surrounding tissues. Free radicals in the inflammation zone are effective in the onset and progression of the disease, as evidenced by increased levels of isoprostane and prostaglandin in the synovial fluid of patients (Pizzino et al., 2017). In addition, age-

related hearing loss, cataract, and retinal degeneration are thought to be caused by the diseases caused by oxidative stress caused by ROS (Brieger et al., 2012).

1.2. Hypochlorous Acid (HOCl)

Hypochlorous acid is an important member of reactive oxygen species bearing outstanding reactivity which is still not fully explainable. HOCl is the most widely used disinfectant and is used as a bleach in daily life. As well as other reactive oxygen species, HOCl also plays an important role in cells' defending system against invaders (Dukan, Belkin and Touati, 1999). Myeloperoxidase enzymes catalyze the reaction between hydrogen peroxide, which is produced by active phagocytes, and chlorine ions to produce HOCl (Kulcharyk and Heinecke, 2001). ROS produced by neutrophils to inhibit or kill cell growth of phagocytosis bacteria is known as hypochlorous acid (McKenna and Davies, 1988). Also, HOCl is generated in some macrophages and monocytes.

1.2.1. Biological Actions of HOCl

Oxidation or chlorination of hypochlorous acid neutralizes harmful bacterial endotoxins or exotoxins (Sam and Lu, 2009). For example, *Porphyromonas gingivalis*, which has damaged periodontal tissues, has been reported to reduce the effect of cysteine proteases (Curtis, Aduse-Opoku and Rangarajan, 2001).

HOCl is transformed into different reactive oxygen species via intracellular reactions. For example, it reacts with amines and ammonium ions and produces toxic amines such as monochloramine (NH_2Cl) (Sam and Lu, 2009; Villamena, 2017). As another important example, free or protein-bound iron converts HOCl to hydroxyl radical. In addition, the reaction of HOCl with hydrogen peroxide or fatty acid peroxide produces singlet oxygen (Villamena, 2017). Hypochlorous acid also reacts with low mass biomolecules and antioxidants such as GSH, ascorbate, uric acid, taurine, and phenol at different reaction rates. In addition, it has been observed that they react with thiol structures. Its oxidation activity against thiol-containing proteins depends on pKa (Yang, 2009; Villamena, 2017). The amino acids, peptides, and proteins essential for biological systems can react rapidly with HOCl (Kulcharyk and Heinecke, 2001). In this case, the reaction rate sequence can be shown as Met > Cys >> cystine ~ His ~ α amino acid > Trp > Lys >> Tyr ~ Arg > backbone amides > Gln ~ Asn (Yang, 2009). HOCl,

which is known to interact with proteins, contributes to mutagenesis when it interacts with DNA. The HOCl-mediated oxidation of DNA can be accomplished by chloramine or by direct oxidation of HOCl. During the oxidation, amino groups or hetero NH groups of the DNA bases are chlorinated and oxygenated. Because H is lost, it causes double-stranded separation due to DNA denaturation or strand breakage (Villamena, 2017).

1.2.2. Cytotoxicity of HOCl

It has been noted that excess amount of HOCl has a cytotoxic effect on mammalian cells (Yang, 2009). Two main approaches have been reported to prevent the cytotoxic effect of HOCl; inactivation of the MPO enzyme and the usage of reducing agents (Clark and Szot, 1980). Endothelial cells, red cells, and mammalian cells, such as tumour cells, demonstrate the cytotoxic effect of HOCl once again. Cell lysis is defined as the destruction of the cell wall or membrane resulting from the release of cellular content by breaking down by harmful organisms such as chemical, physical or virus. It is known that HOCl plays an effective role in cell lysis. Low concentrations of HOCl lead to apoptic cell death (Clark and Szot, 1980), (Yang, 2009), (Kulcharyk and Heinecke, 2001). HOCl also causes irreversible loss of intracellular GSH. (Pullar et al., 2000; Jeitner et al., 2016).

Several studies have revealed that HOCl provides many benefits to the cell at low concentrations. However, increased oxidative stress in the cell is giving various damages. The increase in HOCl concentration in the cell takes place as endogenous and exogenous, just as in other reactive oxygen species. Conditions that increase oxidative stress are directly related to the increase in HOCl. In addition, its endogenous concentration depends on MPO. HOCl interacts with many biological molecules in the cell and oxidizes proteins, fatty acids, DNA and RNA that have an important role in the functioning of vital functions. During these oxidations, undesirable by-products may be formed or makes biomolecules unfunctional. An important issue is that when HOCl interacts with DNA, it can cause serious changes in the structure of DNA. This may lead to the miscoding of DNA, as well as the separation of the double strand of DNA. In the light of all this information, HOCl is known to cause various diseases. It is known to cause cardiovascular diseases (such as coroner artery diseases), inflammatory diseases (such as rheumatoid arthritis), neurodegenerative diseases (Alzheimer, Parkinson),

cystic fibrosis, kidney diseases, and some cancers. (Curtis, Aduse-Opoku and Rangarajan, 2001; Clark and Szot, 1980; Pullar, Vissers and Winterbourn, 2000; Rao and Anand, 2010; Jeitner et al., 2016; Casciaro et al., 2017).

1.3. Detection Methods

Excessive amounts of reactive oxygen species can cause fatal damages to the cell. In light of the above-mentioned researches, it is very important to identify and quantify the type of ROS which plays key roles in many diseases. Based on this situation, the detection methods which are of high importance are examined from the past to the present. Electrochemical detection methods, titrimetric and thermochemical methods, colorimetric and fluorometric methods are methods frequently used for ROS detection. Colorimetric and fluorometric methods are advantageous in many respects compared to other methods. Ease of preparation, fast response, selectivity, and sensitivity, non-destructive, cheap instrumentation are some of the major advantages of colorimetric and fluorometric methods over many other methods.

1.3.1. Photo-induced Electron Transfer (PET)

In the design of colorimetric and fluorometric methods of detection are generated using various mechanisms such as photo-induced electron transfer (PET), internal charge transfer (ICT) and many others. PET appears in many natural and artificial processes. For example, many basic operations such as photosynthesis, organic reactions or imaging devices are constructed on PET mechanism. The most basic definition of PET is the transfer of an electron from a donor molecule to the acceptor molecule. This transfer occurs in the presence of light and continues by excitation the electron with light (Williams, 2007; Griesbeck, Hoffmann and Warzecha, 2007).

PET mechanism one of the most popular approaches in fluorogenic probe designs. In general, a fluorescent based-sensors consist of three units; fluorophore, spacer, and receptor. Fluorophores are known as chemical structures that emit light a certain wavelength when excited by a source. In a well-designed PET-based sensor the HOMO-LUMO energies of fluorophore and receptor unit should perfectly match to each other. For example, when the fluorophore is stimulated, the energy transferred to the receptor and prevents the emission of light thus it is called "off mode". In "on mode", the energy of fluorophore and receptor do not match and fluorophore emits light

when excited. It is retained here when it reaches the analyte receptor site due to the PET principle (Figure 1.3.) (Silva, Moody and Wright, 2009).

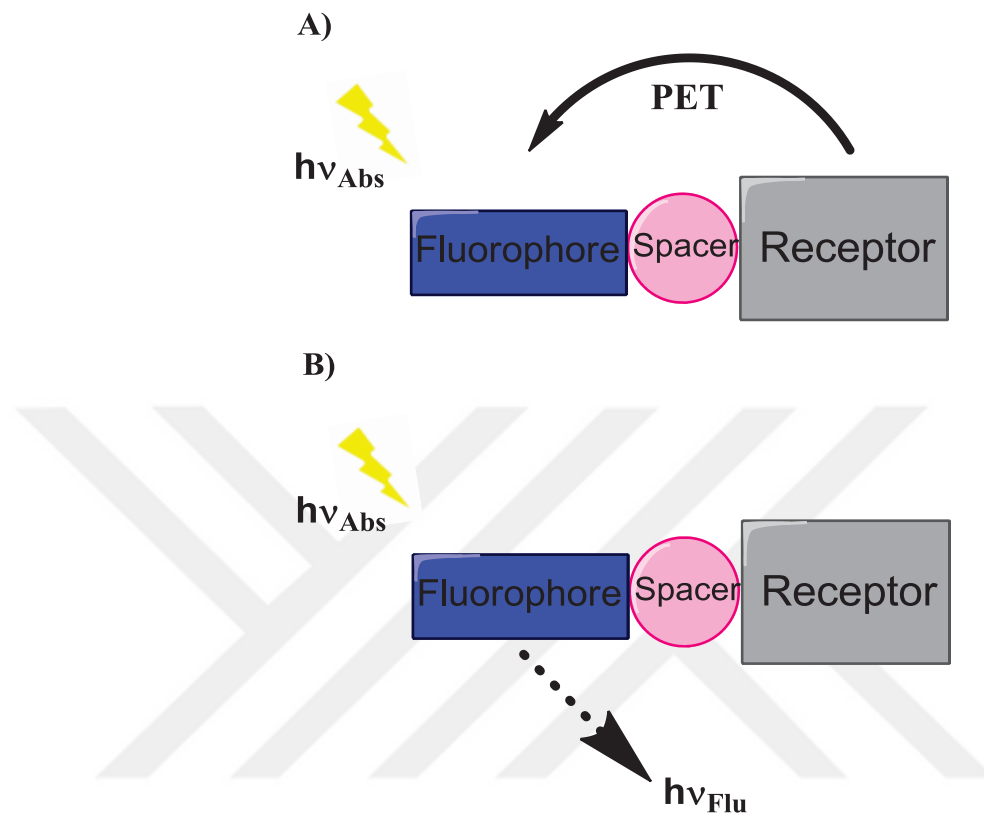

Figure 1.3. Representation of PET mechanism. A) "off" state B) "on" state

(Source: Silva, Moody and Wright, 2009)

PET mechanism can be explained by orbital energy diagrams. As shown in Figure 1.4., PET takes place when the HOMO energy of receptor lay between HOMO-LUMO energy of fluorophore. When the fluorophore is stimulated by light, one of its electrons emerges to the level of LUMO energy level. In general, the excited electron wants to return ground state and release its energy as light or heat. However, in such a system, the receptor donates its one electron to the half-filled HOMO of the fluorophore (more stable due to the energy level) and prevents the return of excited electron. This process is called as quenching. The PET mechanism can be cancelled by the interaction of the receptor with an analyte. When receptor interacted with an analyte its HOMO-LUMO energies changed and become lower than fluorophore. In that case, analyte-receptor complex does not transfer one of its HOMO electrons to empty HOMO orbital of the excited fluorophore. After excitation, the excited electron can return its ground

state by emitting light or heat. In such a process PET mechanism becomes cancelled. (Williams, 2007; Griesbeck, Hoffmann and Warzecha, 2007; Silva, Moody and Wright, 2009).

1.4. Fluorescent Probes

Considering the detrimental effects of hypochlorous acid to the cells, detection studies were of great importance. To this purpose, lots of fluorescent probes have been designed based on PET mechanism. In these studies, various fluorophores such as coumarin, fluorescein, rhodamine, BODIPY, and naphthalimide have been functionalized with a PET quencher and their sensing properties investigated. (Hu, Ye and Yang, 2017).

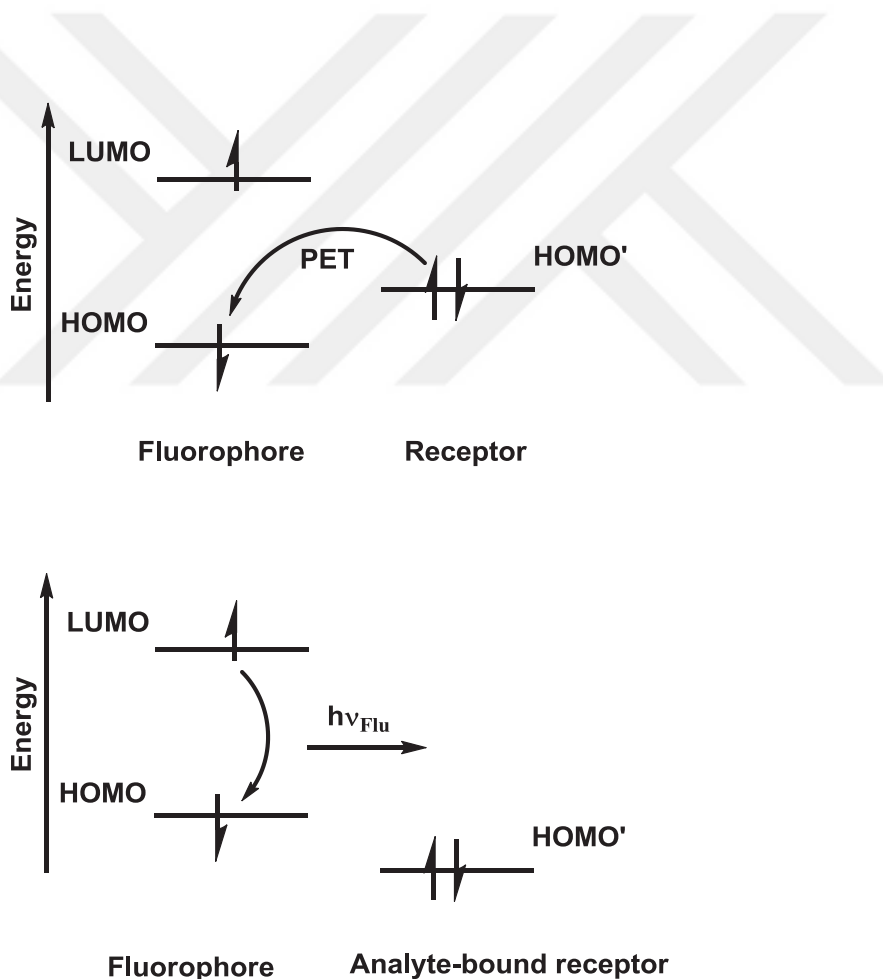
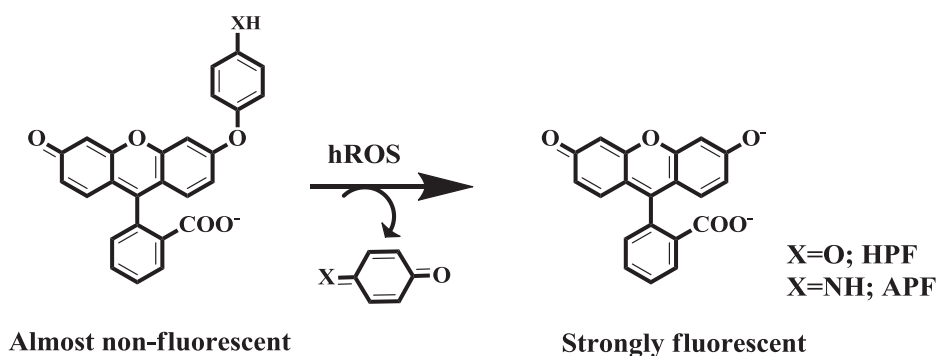

Figure 1.4. Representation of molecular orbital diagrams of fluorophores and receptor.

(Silva, Moody and Wright, 2009)

1.5. LITERATURE WORK

The importance of hypochlorous acid in biological systems has been proven and the effects of higher amounts to the body have reported. Based on this information, a variety of fluorogenic probes have been developed for the detection of hypochlorous acid in the aqueous environment and living organisms. Setsukinai and co-workers have reported an important study for the detection of hypochlorous acid. The 2-[6-(4'-hydroxy)phenoxy-3H-xanthen-3-on-9-yl]benzoic acid (HPF) and 2-[6-(4'-amino)phenoxy-3H-xanthen-3-on-9-yl]benzoic acid (APF) probe is a fluorescein derivative have been designed based on the knowledge that the functionalization of the phenolic hydroxyl group in the 6a position by the electron-rich aromatic ring can quench the fluorophore via PET mechanism. (Figure 1.5.) HPF and APF probes are almost non-fluorescent and were expected to fluoresce after undergoing the O-dearylation reaction with hypochlorous acid. When probe molecules treated with increasing concentration of HOCl, they produced an increasing turn on signal. Based on the results, it was observed that the fluorescence intensity of APF increased in a dose-dependent manner. The similar results obtained for HPF as well, and the combination of these two probes proved to be selectively detecting OCl^- and succeeded in imaging them in neutrophils. (Setsukinai et al., 2002).



$$\left[\begin{array}{l} \text{HPF: } \epsilon_{454} = 28000 \text{ (M}^{-1} \text{ cm}^{-1}\text{)}, \Phi_{\text{fl}} = 0.006 \\ \text{APF: } \epsilon_{455} = 24000 \text{ (M}^{-1} \text{ cm}^{-1}\text{)}, \Phi_{\text{fl}} = 0.008 \end{array} \right] \left[\begin{array}{l} \text{Fluorescein: } \epsilon_{492} = 84000 \text{ (M}^{-1} \text{ cm}^{-1}\text{)}, \Phi_{\text{fl}} = \\ 0.85 \end{array} \right]$$

Figure 1.5. Demonstration of o-dearylation of HPF and APF with hROS

(Source: Setsukinai et al., 2002)

Another important study aiming to detect and visualize HOCl in the aqueous and biological environment was performed by Kenmoku and colleagues. They aimed to develop a tetramethylrhodamine (TMR) based probe due to its outstanding photochemical properties such as high fluorescence intensity, long excitation and emission wavelength (550-600 nm). The most important feature of hydroxymethyltetramethylrhodamine (HMTMR) is its fluorescence and absorbance characteristics totally environmentally dependent (the high intensity in protic solvents, the low intensity in aprotic solvents, etc.). It was determined that these differences were caused by intramolecular spirocyclization in C9 and deconjugation of the TMR fluorophore. While the rhodamine derivative is non-fluorescent in its spirocyclic form it produces high fluorescence in its open form due to the regeneration of conjugation. The product of the interaction between the probe molecule and the analyte (HOCl) was an open form of the probe molecule. The team has also developed another example of the same strategy in which heteroatom replaced with sulphur. The thiol-containing probe is non-fluorescent and ensures higher stability of the spirocyclic structure in the physiological conditions of the targeted probe (Figure 1.6.), (Kenmoku et al., 2007).

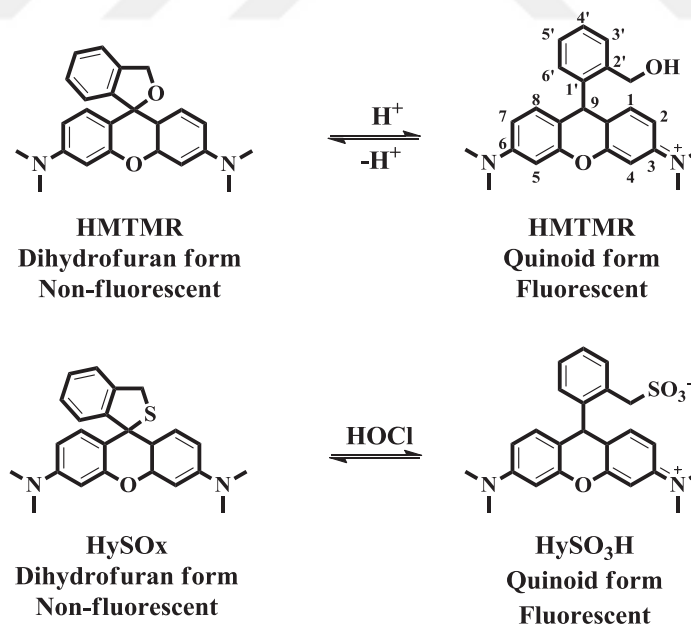

Figure 1.6. Sensing representation of probe and HOCl

(Source: Kenmoku et al., 2007)

Sun and co-workers used BODIPY as a fluorophore which offers many advantages over others in terms of photochemical properties in their study for the detection of HOCl. Here, the probe constructed on a receptor unit which undergoes HOCl specific reaction to rather than other ROSs found in biological systems was investigated. In this context, the p-methoxyphenolone was oxidized to benzoquinone in the presence of one equivalent of NaOCl. The "turn on" mechanism of BODIPY derivative after interaction with HOCl can be explained by the PET process. Since the HOMO energy level of the p-methoxyphenol moiety is in between the HOMO-LUMO energy levels of BODIPY the electron can transfer from p-methoxyphenol to BODIPY when it is excited. This process quenches the emission of the probe molecule. After treatment of probe with HOCl, the HOMO energy level of the benzoquinone becomes lower than the HOMO energy level of BODIPY, which prevents the PET process and gives the product fluorescence on. (Figure 1.7.), (Sun et al., 2008).

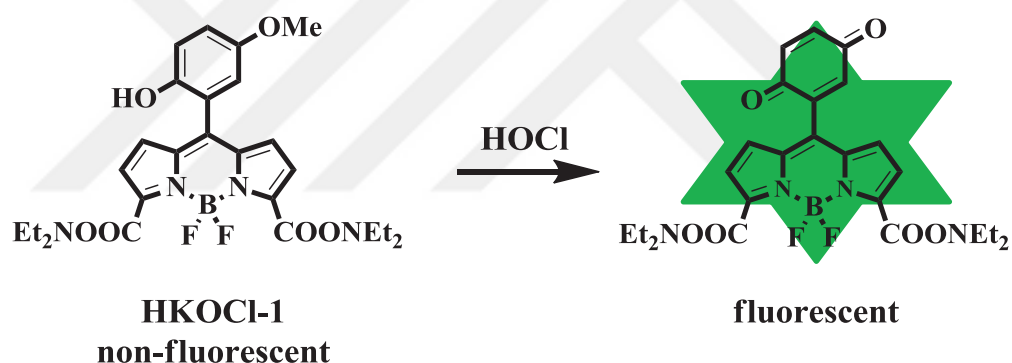

Figure 1.7. Demonstration of sensing mechanism

(Source: Sun et al., 2008)

A remarkable feature of this study is the ability of the probe to visualize HOCl in living cells. The probe not only enables to detect the presence of exogenous HOCl but also detects endogenous hypochlorous acid which is generated by the MPO/H₂O₂/Cl⁻ system. The cells treated with probe molecule initially were non-fluorescent. However, stimulation of HOCl production by the addition of LPS/IFN- γ and PMA caused oxidation of p-methoxyphenol to benzoquinone and the fluorescence signal turned on. (Sun et al., 2008).

Another important receptor unit for the detection of HOCl are imines or aldoximes. When the C=N isomerization is the dominant decay process of stimulated

states, molecules containing non-hybridized cyanide bonds generally do not have a fluorescent property. However, compounds that contain a cyclic C=N bond or complex with a guest species to limit the rotation of the C=N bond show strong fluorescent properties (Cheng et al., 2011).

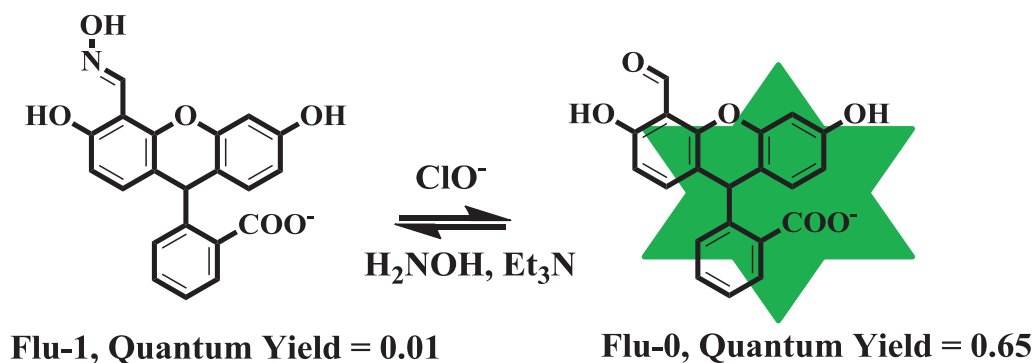

Figure 1.8. Interaction of probe with ClO^-

(Source: Cheng et al., 2011)

As another prior knowledge, the aldehyde groups can be protected as oximes and, under certain conditions, can be quickly deprotected by HOCl. Cheng and co-workers have made a new prediction based on this information. They envisaged that the non-fluorescent oxime form would be converted into aldehydes in the presence of HOCl and thus the molecule would gain fluorescence. It is succeeded that the C=N bond isomerization would be removed by HOCl rather than the classical approach of inhibiting C=N isomerization and that the formed aldehyde form would show fluorescence intensity. As a result of this work, Cheng et al. presented a good example of "off-on" sensors (Cheng et al., 2011).

Another important study for the detection of hypochlorous acid was carried out by Emrulloğlu et al. In this study, BODIPY (boron-dipyrromethene) dye was chosen as fluorophore and the information about the inhibition of C=N bond isomer was used. The fluorescence of BODIPY quenched with the oxime moiety due to the isomerization of the C=N group and the loose of the planar structure of the molecule. When the designed probe interacts with HOCl, the intensity of the emission has increased considerably. The interaction of the probe with HOCl produces a highly fluorescent new compound which is nitric oxide derivative of BODIPY molecule. The formation of this new molecule has proved by mass analysis. (Emrulloğlu et al., 2013).

One of the important features of the study is the rapid response of the probe in the physiological conditions (pH 7.4) that can be seen even with the naked eye. Furthermore, the "turn on" type of probe allowed the monitor presence of exogenous HOCl in cellular media. (Emrulloğlu et al., 2013).

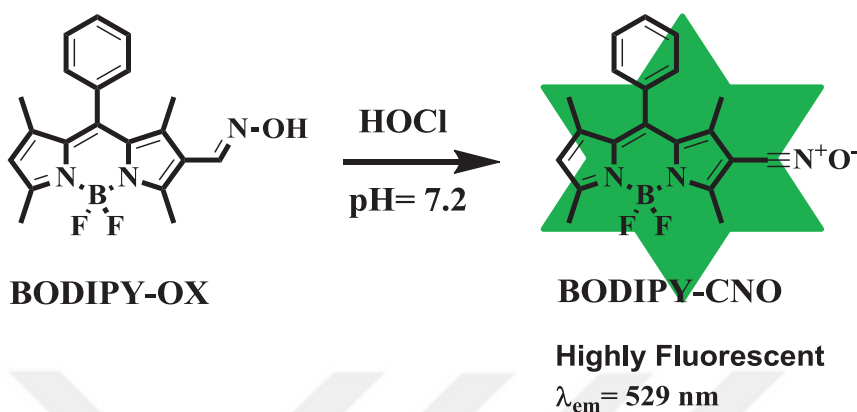

Figure 1.9. Representation of Sensing mechanism

(Source: Emrulloğlu et al., 2013)

7-Nitrobenz-2-oxa-1,3-diazole (NBD) is another preferred molecular framework due to the advantages of derivatives. These advantages include biocompatibility characteristics, spectral properties, cellular membrane penetration capacity, and easy functionality. Shen et al., mainly focused his researches on NBD based probes to detect heavy metals according to PET mechanism. Based on their knowledge, they considered selenomorpholine can detect HOCl. They found that the fluorescence of probe was poor in cases where NBD was conjugated with selenite. However, the interaction of probe with HOCl produce a "turn on" signal which is because of selenite oxidation. (Figure 1.10.), (Shen et al., 2015).

Another interesting feature of this study was that the oxidized product can be reduced to its initial form by antioxidants. It was reported that the findings obtained were usable for the reversible detection of HOCl inside the cells. (Shen et al., 2015).

The charge transfer to the electron-free receptor part of different molecules from an electron-rich rotating group is called intermolecular charge transfer. This is called intramolecular charge transfer (ICT) if the receptor and donor are in the same molecule (Misra and Bhattacharyya, 2018).

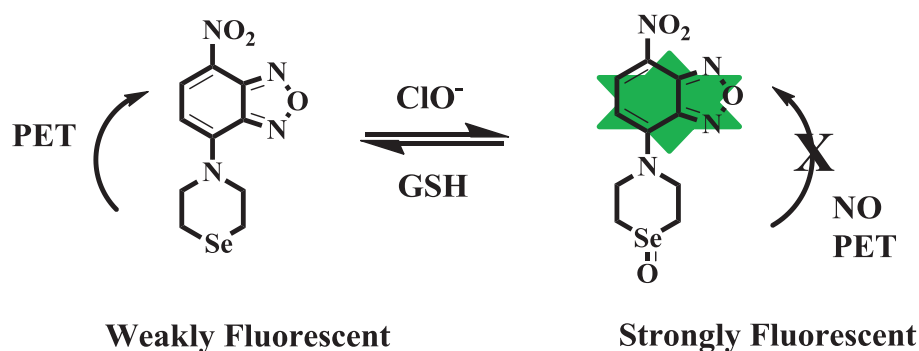

Figure 1.10. Sensing Mechanism of probe and ClO^-

(Source: Shen et al., 2015)

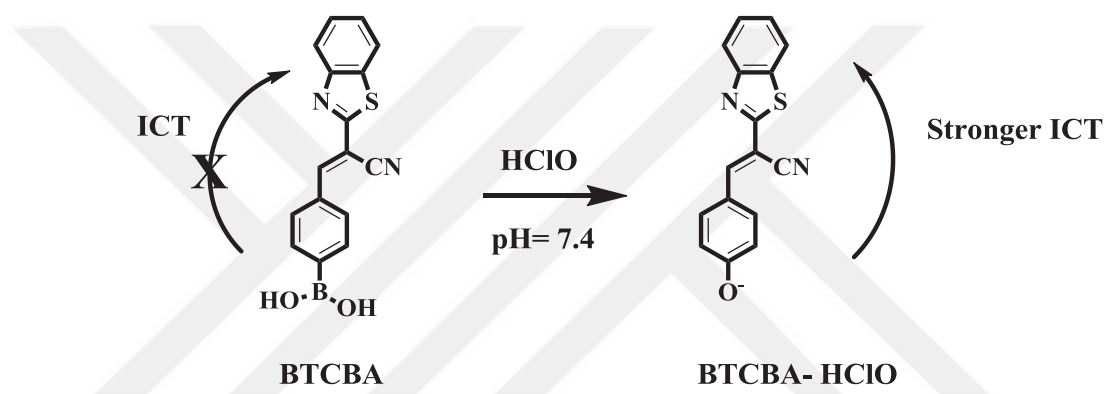

Figure 1.11. Sensing Mechanism of BTCBA based on ICT Mechanism

(Source: Wang et al., 2017)

Various chemosensors have developed by using ICT mechanism. Wang et al. developed a HOCl-sensitive, ratiometric, colorimetric and fluorescent chemodosimeter using ICT. The cyaninylene dye was functionalized with a boronic acid moiety that serve as receptor unit which hydrolysis to phenolate derivative in the presence of HOCl. The sensor has shown to have a large redshift after treatment by hypochlorous acid due to the change in its electronic structure. They also reported that the probe provides a naked eye detection of HOCl in which the color of probe solution turns from colorless to green after interaction with HOCl. (Wang et al., 2017).

Another important class of fluorophores is merocyanine dyes bearing large stock shifts, high quantum yield, and good water solubility. Ponnuval et al. developed a new, simple, selective and water-soluble sensor based on merocyanine involving an indole receptor unit in its structure to monitor hypochlorous acid. The probe works based on

the ICT mechanism and produces a strong blue fluorescence emission at the time of interaction with HOCl. In ICT mechanism, HOMO electron donor is spread on the NH-part of the indole, while LUMO is a small electron interruption in the merocyanine unit and an intermolecular charge transfer occurs in between these two units. It was also noted that naked eye detection is possible; the color of the solution turns red from the colorless after HOCl treatment.

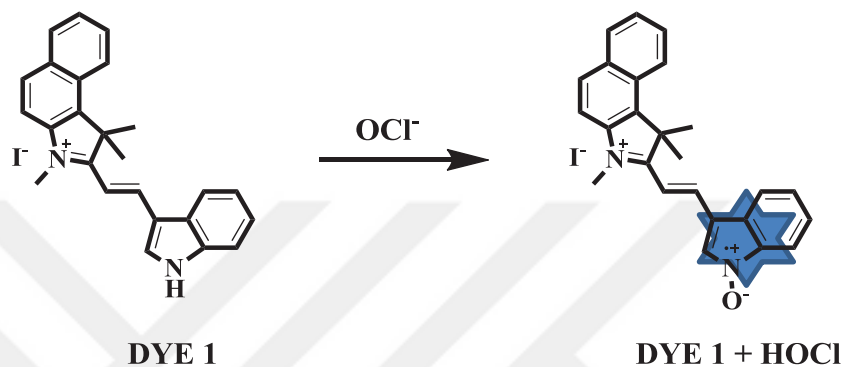

Figure 1.12. Interaction of probe and HOCl

(Source: Ponnuval et al., 2017)

In addition, the test strips saturated with the probe have successfully detected the presence of different concentrations of HOCl in real samples. Moreover, the group has demonstrated the applicability of HOCl sensing event in the living cells. (Ponnuval et al., 2017).

Another study for the detection of HOCl was performed by Peng et al. They have designed and synthesized a photo-activatable fluorogenic probe for direct detection of ClO^- near the cellular membrane. Probe design involves three key units in which fluorescein dye has functionalized with a photolabile group (nitrobenzyl), HOCl sensitive receptor unit (benzoyl) and a targeting unit (cholesterol). (Peng et al., 2018).

In biological application, cells treated with probe molecule and expected to localize in the cell membrane because of the presence of cholesterol moiety. When probe molecule localized in the cellular membrane, UV light triggered the sensing event via removing nitrobenzyl group from the probe molecule which is completely in off mode due to the disrupted conjugation. Then, the presence of HOCl detected by

receptor unit via benzoyl hydrolysis and fluorescein starts to emit in the green channel.
(Peng et al., 2018).

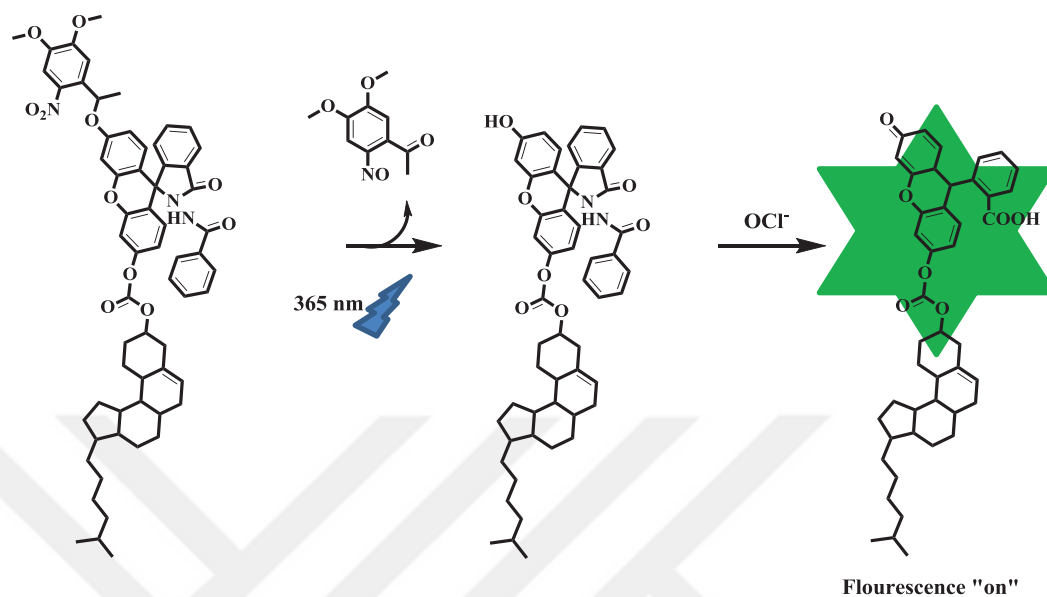

Figure 1.13. The strategy of photocontrollable fluorogenic probe in the detection of ClO^- near membrane

(Source: Peng et al., 2018)

CHAPTER 2

EXPERIMENTAL STUDY

2.1. General Methods

All reagents were purchased from commercial suppliers (Aldrich and Merck) and used without further purification. ^1H NMR, ^{13}C NMR and ^{31}P NMR were measured on a Varian VNMRJ 400 Nuclear Magnetic Resonance Spectrometer. UV absorption spectra were obtained on Shimadzu UV-2550 Spectrophotometer. Fluorescence emission spectra were obtained by using Varian Cary Eclipse Fluorescence Spectrophotometer. Samples were contained in 10.0 mm path length quartz cuvettes (2.0 mL volume). Upon excitation at 380 nm, the emission spectra were integrated over the range 400 nm to 600 nm (Both excitation and emission slit width 5 nm / 5 nm).

2.2. Synthetic Methods

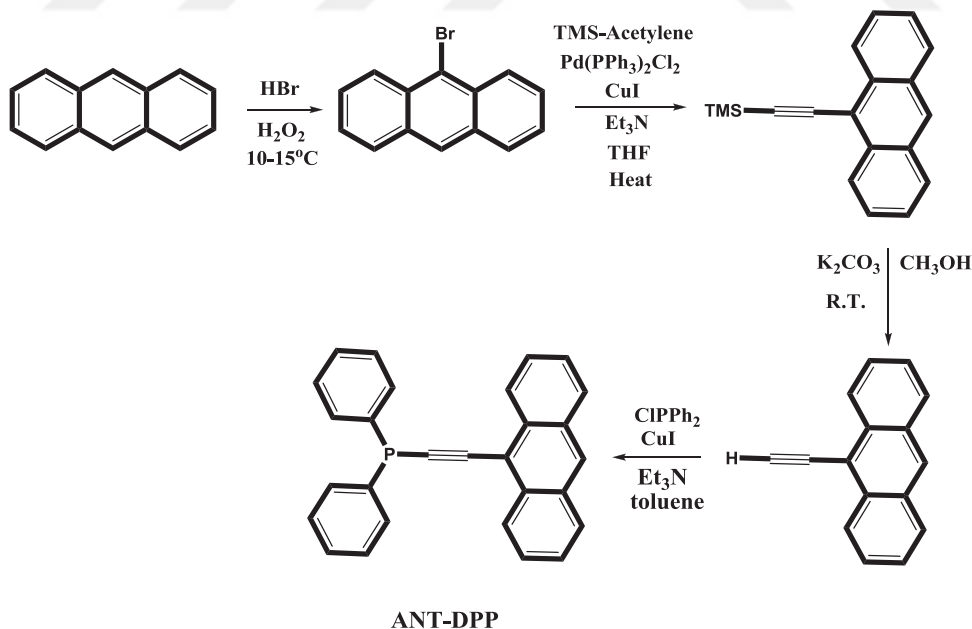

Figure 2.1. The Pathway of Synthesis of ANT-DPP

Anthracene was purchased from commercial suppliers. 9-bromoanthracene was obtained by a conventional bromination reaction. The Sonogashira-coupling reaction of

brominated anthracene with ethynyltrimethyl silane performed. Desilylation of TMS group obtained by treatment of (anthracen-9-ylethynyl)trimethylsilane with potassium carbonate in methanol and used immediately due to the stability problems. The resulting anthracene-acetylene molecule was reacted with chlorine diphenylphosphine in a copper iodide catalysed manner and the title compound (**ANT-DPP**) was obtained. In Figure 2.1., the synthetic route of **ANT-DPP** is shown.

2.2.1. Synthesis of 9-bromoanthracene

To a solution of anthracene (200 mg, 1.12 mmol) in DCM (5 ml), HBr (110 mg, 2.45 mmol) was added and the reaction stirred vigorously with a magnetic stirrer. The reaction temperature was kept constant at 10-15 °C and hydrogen peroxide (120 mg, 1.12 mmol) was added slowly to the mixture. Then, the reaction mixture was allowed to stir at room temperature under Argon atmosphere for overnight. When the reaction completed, solvent was evaporated under reduced pressure and the crude product purified by column chromatography on hexane/ethylacetate (10:1) solvent system. (160 mg, Yield 80%, yellow solid) (Vyas et al., 2003).

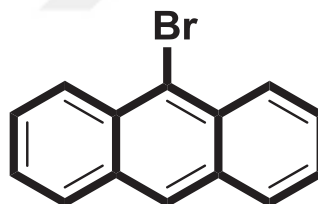

Figure 2.2. 9-bromoanthracene

2.2.2. Synthesis of (anthracene-9-ylethynyl)trimethylsilane

9-bromoanthracene (100 mg, 0.39 mmol) was dissolved in THF (5.0 mL). Pd(PPh₃)₂Cl₂ (7.0 mg, 0.0098mmol), triethylamine (2.0 ml) and CuI (3.3 mg, 0.0017 mmol) were added to the reaction medium. The reaction was heated to reflux temperature. Finally, TMS-acetylene (60.0 mg, 0.428 mmol) was added to the mixture and reaction mixture stirred under argon atmosphere for overnight. The solvent was evaporated in vacuo and the crude product purified by column chromatography (hexane/ethylacetate (10: 1)) in the appropriate solvent system. (63.3 mg, Yield 60%) (Heuft et al., 2001).

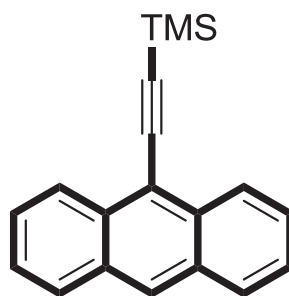

Figure 2.3. (anthracen-9-ylethynyl)trimethylsilane

2.2.3. Synthesis of 9-ethynylanthracene

(Anthracen-9-ylethynyl) trimethylsilane (100 mg, 0.36 mmol) dissolved in methanol (3.0 mL) and potassium carbonate (excess) added. The progress of the reaction was monitored by TLC. The reaction was continued until the starting product was not observed. When the reaction completed, the solvent was evaporated. Then, solid dissolved in ethyl acetate and extracted with water, dried over sodium sulphate and purified by silica gel column chromatography. (66.4mg, Yield 90%, yellowish solid) (Heuft et al., 2001).

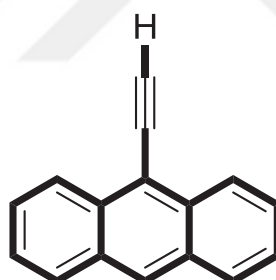

Figure 2.4. 9-ethynylanthracene

2.2.4. Synthesis of (anthracen-9-ylethynyl)diphenylphosphine

9-ethynylanthracene (100mg, 0.49mmol) dissolved in dry toluene (3.0 mL). To this solution, CuI (1.2mg, 0.0063mmol) and ClPPh₂ (436.3mg, 1.98mmol) (4eq) were successively added. Finally, triethylamine was added and the reaction mixture heated up to 80°C. The progress of the reaction was monitored by TLC. After completion of the reaction, the solvent was evaporated and the crude product purified by column chromatography. For the spectroscopy measurements product further purified by crystallization in hexane. ³¹P NMR (CDCl₃, 162 MHz) δ (ppm): -32.45. ¹H NMR (400

MHz, CDCl₃) δ (ppm): 8.55 (dq, J = 8.7, 1.2 Hz, 2H), 8.46 (s, 1H), 8.03-8.00 (m, 2H), 7.87-7.82 (m, 4 H), 7.58-7.49 (m, 4 H), 7.46-7.37 (m, 6 H). ¹³C NMR (100 MHz, CDCl₃) δ (ppm): 136.5 (d, J = 7.0 Hz), 133.1 (d, J = 2.0 Hz), 132.7 (d, J = 21.0 Hz), 131.0, 129.1, 128.9, 128.7, 128.4, 126.9, 126.6, 125.7, 116.6 (d, J = 2.0 Hz), 104.6 (d, J = 4.0 Hz), 97.4 (d, J = 8.0 Hz). (85.5mg Yield % 50, yellow solid.)

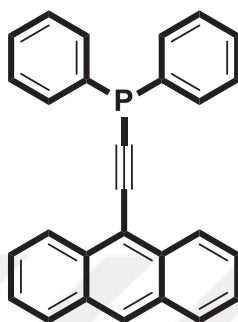

Figure 2.5. (anthracen-9-ylethynyl)diphenylphosphine

2.3. Determination of Detection Limit

The detection limit was determined based on fluorescence titration experiments. For determination of detection limit firstly, the emission intensity of **ANT-DPP** (10 μ M) was measured by 10 times and the standard deviation of blank was calculated. In the 0.5-1 μ M concentration range, a good linear relationship between HOCl and fluorescence intensity was obtained (R=0,9815). The detection limit was calculated by using the equation: detection limit = 3 σ _{bi}/m.

σ _{bi} : the standard deviation of blank measurements,

m : the slope between intensity versus sample concentration.

CHAPTER 3

RESULTS & DISCUSSION

In this study, an anthracene based “turn on” probe for the selective and sensitive detection of hypochlorous acid was designed, synthesized and its sensor characteristics were examined by spectroscopic analysis and live cell imaging studies. A probe molecule constructed by three important units: fluorophore, spacer, and receptor. Here, anthracene was selected as fluorophore moiety due to its outstanding chemical and photophysical properties such as robustness to chemicals, ease of functionalization, high extinction coefficient and high quantum yield. To the best of our knowledge, it was the first time diphenyl phosphine moiety was used as a receptor unit in which the phosphorus can only oxidized to phosphorous oxide in the presence of hypochlorous acid. These two units were connected to each other with an acetylene spacer.

As shown in Figure 3.1., fluorescence emission of **ANT-DPP** quenched by PET mechanism in which the lone pair electrons of phosphorus are transferred to the HOMO energy level of fluorophore during light irradiation (*off mode*). However, a strong increase in fluorescence intensity was observed in the presence of HOCl due to the cancellation of PET mechanism (*on mode*). Because of its off-on mode, the **ANT-DPP** was called as "turn-on" probe.

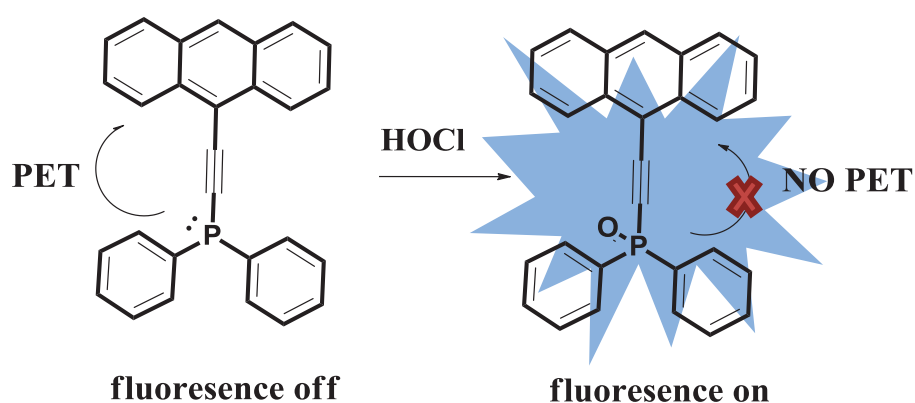

Figure 3.1. Reaction-based detection of HOCl

3.1. Spectroscopic Analysis

3.1.1. Solvent Determination Study

The optimization studies were commenced with the determination of the suitable solvent system for HOCl sensing event. For the applicability of sensing event into the biological systems has crucial importance to select a solvent system close to physiological conditions. To this purpose, various combinations of solvent systems such as CH₃CN/HEPES, CH₃CN/phosphate buffer, DMF/phosphate buffer, and ethanol/phosphate buffer systems (pH: 7.0) were carefully screened. As shown in Figure 3.2., ANT-DPP showed very similar sensitivity to HOCl in all solvent systems. Among all screened solvent systems the CH₃CN/HEPES was determined to be the most suitable one for further spectroscopic measurements because of the ease of operation.

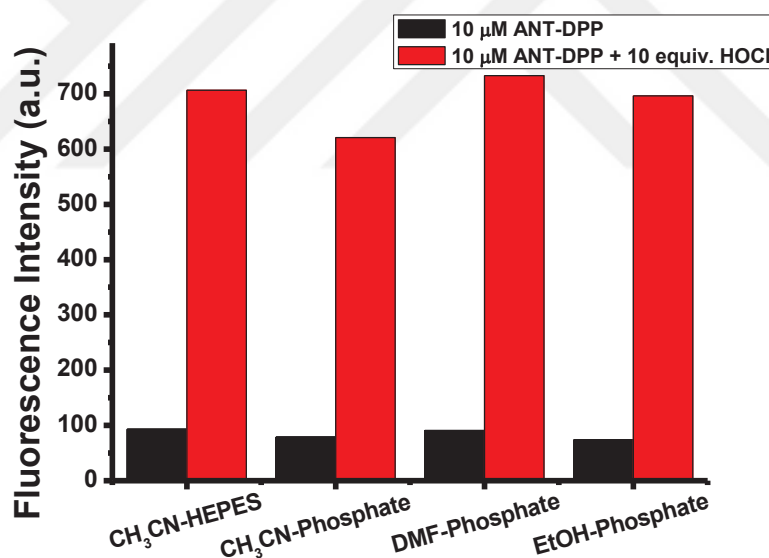

Figure 3.2. Solvent screening of ANT-DPP (10μM) towards addition of HOCl (100μM), (λ_{ex} : 380nm, λ_{em} : 460nm, 25°C)

3.1.2. Water Content Screening Study

The next step of the optimization studies was the determination of the effect of water content on the sensitivity of HOCl detection. Spectroscopic analysis was performed by changing the proportions of water in CH₃CN/HEPES (pH:7.0) system. As

seen in Figure 3.3., **ANT-DPP** (10 μM) treated with HOCl (100 μM , 10 equiv.) in different ratios of water at pH 7. The probe itself has no fluorescent response in the absence of HOCl upon excitation at 380 nm. The probe emission exhibits a significant increase in the presence of HOCl in media for almost all water ratios and produced the highest fluorescence intensity enhancement at a ratio of 1: 1 ($\text{CH}_3\text{CN}/\text{HEPES}$, v: v). It is important to note that the fluorescence enhancement diminished in the higher ratios of water that is due to the solubility problems of the probe molecule. The condition which provides maximum fluorescence enhancement with the highest water content was chosen because of further applicability of sensing event to the biological systems. Biological systems do not tolerate the presence of organic solvents which can be toxic to the cell. Therefore, the ranges in which the amount of organic solvent is high are not preferred.

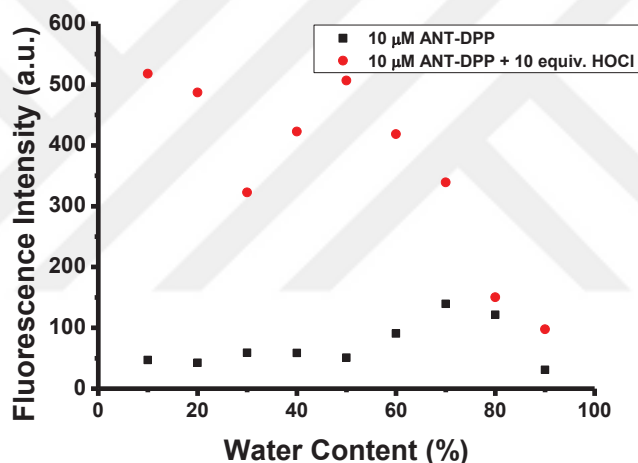

Figure 3.3. Water content solvent system, **ANT-DPP** (10 μM) towards addition of HOCl (100 μM), (λ_{ex} : 380nm, λ_{em} : 460nm, 25 $^{\circ}\text{C}$)

3.1.3. Determination of pH Study

The physiological pH is around 7.4 but in some part of the body, it can be more acidic than this value. To understand the applicability of sensing event the detection behaviour of **ANT-DPP** was investigated at different pH values (10 μM **ANT-DPP** in $\text{CH}_3\text{CN}/\text{HEPES}$ (1:1, v/v)) (Figure 3.4.). According to the results, the probe molecule, **ANT-DPP**, produce fluorescence response to HOCl in all pH values and generates higher increases in more acidic and basic systems. The probe signal is also significantly enhanced by HOCl in physiological conditions which is preferred for further biological applications.

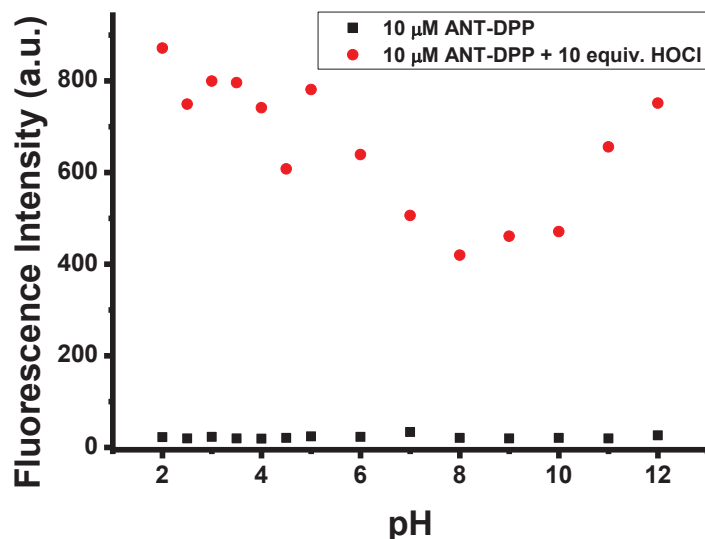

Figure 3.4. pH screening of **ANT-DPP** (10 μ M) towards addition of HOCl (100 μ M) in CH₃CN/HEPES (1:1, v:v), (λ_{ex} : 380nm, λ_{em} : 460nm, 25°C)

3.1.4. Time Profile Study

To complete the optimization the sensing conditions kinetic study performed by treating **ANT-DPP** (10 μ M) at different concentrations of HOCl (1 μ M, 3 μ M, 5 μ M) in CH₃CN/HEPES (pH: 7.0, (1:1, v/v)) and fluorescence signal (at 460 nm) were reported at different time points upon excitation at 380 nm. The immediate enhancement of the fluorescence signal observed with the addition of HOCl. From a careful evaluation of experimental results, it was found that the sensing event reaches its maximum within 60 minutes (Figure 3.5.).

After completion of all above experiments the optimum conditions for sensing event was determined as 10 μ M dye concentration in CH₃CN/HEPES (1:1 (v/v), pH: 7.0) and all spectra collected 60 mins after addition of HOCl.

3.1.5. Fluorescence Titration Study

To understand the boundaries of sensing event the fluorescence titration experiment was carried out by addition of an increasing concentration of HOCl (0 to 200 μ M). A linear increase in fluorescence emission of **ANT-DPP** was observed upon addition of an increasing amount of HOCl and fluorescence enhancement reached to a saturation point in the presence of 200 μ M of HOCl (Figure 3.6.).

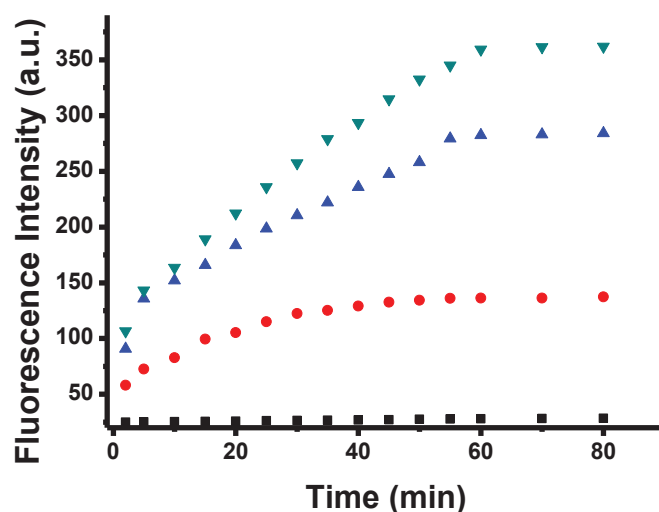

Figure 3.5. Time profile of **ANT-DPP** (10 μ M) towards addition of HOCl (1 μ M, 3 μ M, 5 μ M) in CH₃CN/HEPES (1:1, v:v), (λ_{ex} : 380nm, λ_{em} : 460nm, 25°C)

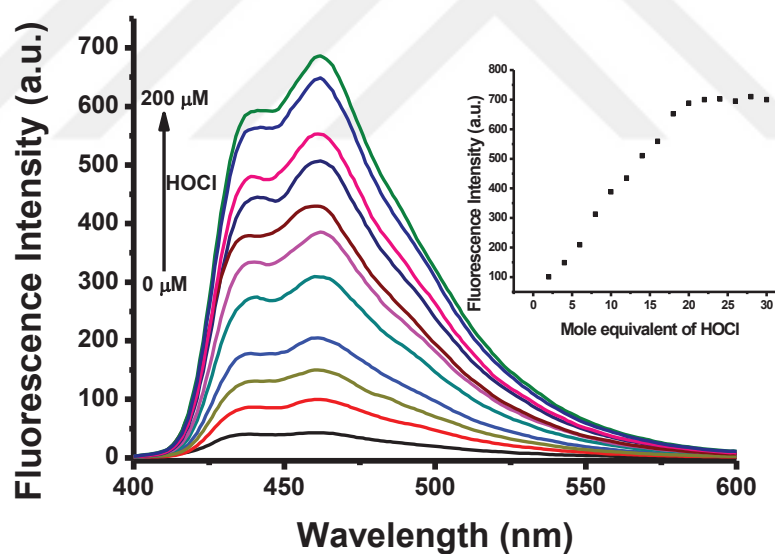

Figure 3.6. Fluorescence titration of **ANT-DPP** (10 μ M) upon addition of HOCl (from 0 μ M to 200 μ M) in CH₃CN/HEPES (1:1, v:v), (λ_{ex} : 380nm, λ_{em} : 460nm, 25°C)

In addition, the limits of **ANT-DPP** probe investigated to determine minimum detectable amount of HOCl in aqueous solutions. As shown in Figure 3.7., the fluorescence titration experiment was performed by the addition of increasing

concentration of HOCl from 0 to 1 μM and the detection limit calculated as 570 nM by using the equation = $3\sigma_{bi}/m$.

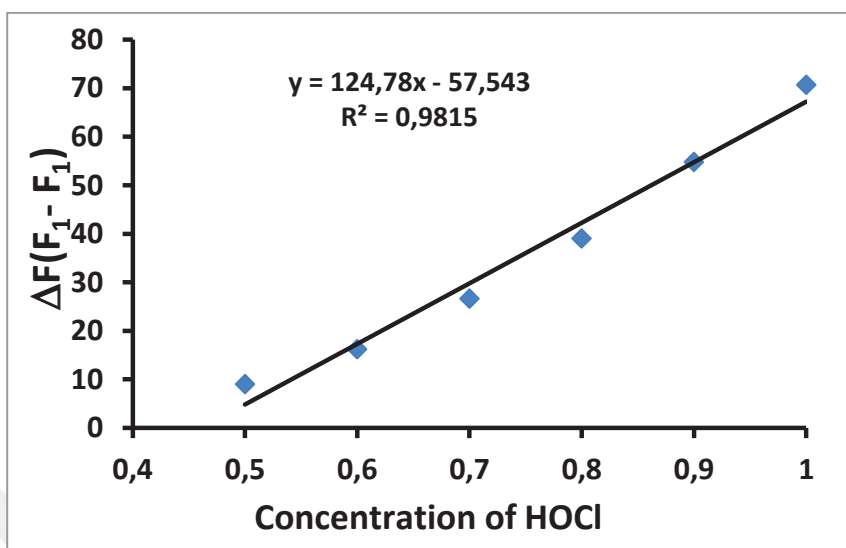

Figure 3.7. Graph used for calculation of detection limit

3.1.6. Absorbance

To complete the photophysical characterization of **ANT-DPP** the absorbance spectrum was measured by using UV-Vis spectrophotometer. As shown in Figure 3.8., the probe molecule, **ANT-DPP**, displays absorption bands peaked at 374 nm, 394 nm, and 416 nm. Upon addition of 10 equivalents of HOCl into the probe solution, the intensity of absorption increased but did not show any significant shift due to the preserved structural integrity (Figure 3.8.).

To finalize the photophysical characterization of **ANT-DPP** quantum yield was measured before and after sensing event by using absorbance and fluorescence data. As expected, the probe, **ANT-DPP**, is almost non-emissive ($\Phi_F=0.048$) due to photoinduced electron transfer from DPP receptor unit. However, inhibition of PET mechanism by the addition of HOCl resulted in a significant increase in fluorescence and quantum yield of oxidized probe was calculated as $\Phi_F=0.6$.

3.1.7. Selectivity and Interference Studies

One of the most important features of a good probe is its selectivity to targeted analyte among all possible interfering species. The selectivity of **ANT-DPP** was

investigated by measuring fluorescence signal in the presence of HOCl or other reactive oxygen species and anions which were H_2O_2 , HO^\cdot , ROO^\cdot , NO^\cdot , NO_2^\cdot , NO_3^\cdot , O_2^\cdot , $^1\text{O}_2$.

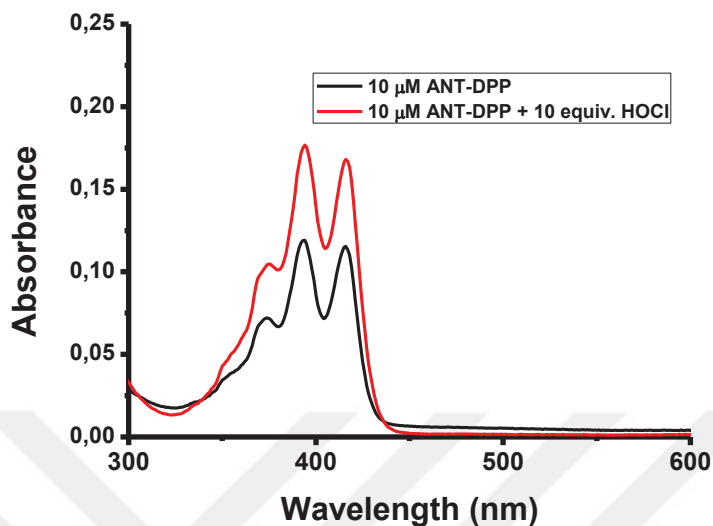

Figure 3.8. Absorbance spectra of **ANT-DPP** (10 μM) and **ANT-DPP + HOCl** (100 μM) in $\text{CH}_3\text{CN}/\text{HEPES}$ (1:1, v:v)

All ROS species and anions were prepared according to literature methods. (Emrulloğlu et al., 2013). As shown in Figure 3.9. the probe stayed “off mode” in the presence of excess amounts of ROS species and only produced an enhancement in fluorescence signal upon addition of HOCl.

The selectivity of **ANT-DPP** was also interrogated by the addition of possible ROS/anions and HOCl together. To a 10 μM solution of probe first other ROS/anions were added and stirred for 60 mins to see any change in fluorescence intensity that measured by fluorescence spectrophotometer. Then, HOCl added to these solutions and fluorescence enhancements measured after 60 mins. As shown in Figure 3.10., there were no significant interference of other ROS/anions to the sensing event. The results are very encouraging to continue the imaging of HOCl in cellular media which may include high amounts of different ROS or anions.

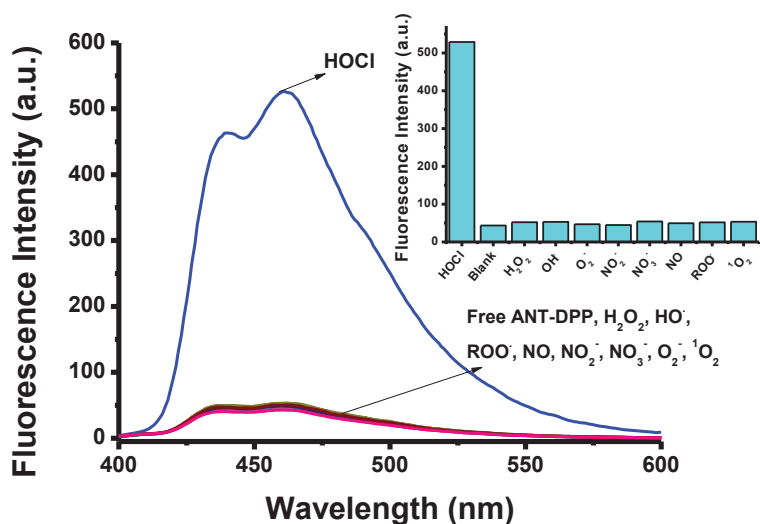

Figure 3.9. Fluorescence titration of **ANT-DPP** (10 μ M) upon addition of other ROS/RNS (200 μ M) in CH₃CN/HEPES (1:1, v:v), (λ_{ex} : 380nm, λ_{em} : 460nm, 25 $^{\circ}$ C)

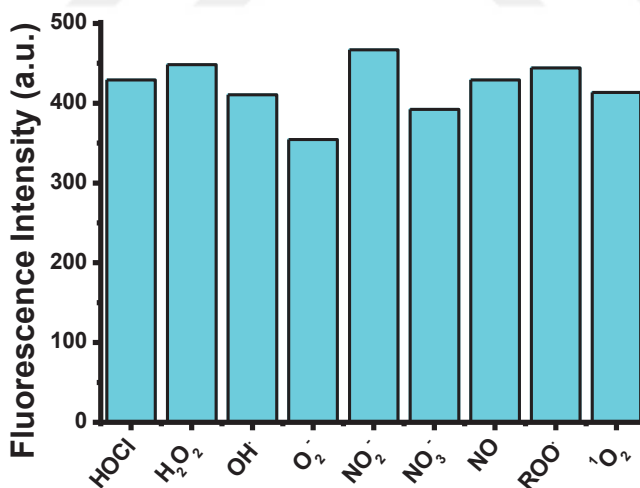

Figure 3.10. Fluorescence titration of **ANT-DPP** (10 μ M) upon addition of other ROS/anions (200 μ M) + HOCl (100 μ M) in CH₃CN/HEPES (1:1, v:v), (λ_{ex} : 380nm, λ_{em} : 460nm, 25 $^{\circ}$ C)

3.1.8. Metal Scanning Study

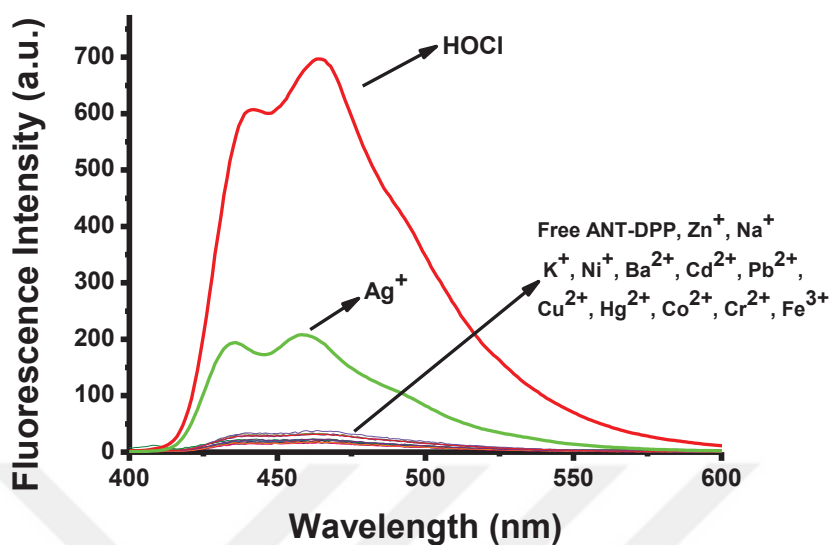

Figure 3.11. Metal scanning of **ANT-DPP** (10 μ M) upon addition of other metals (200 μ M) + HOCl (100 μ M) in CH₃CN/HEPES (1:1, v:v), (λ_{ex} : 380nm, λ_{em} : 460nm, 25°C)

Metal ions play lots of crucial roles in many biological systems. As a further study, the reactivity of **ANT-DPP** to metal cations was investigated. Luckily, **ANT-DPP** did not produced any remarkable signal in the presence of metal cations with different oxidation states. **ANT-DPP** stayed off mode in the presence of excess amounts of cations such as Zn⁺, K⁺, Ni⁺, Na⁺, Ba²⁺, Cd²⁺, Pb²⁺, Cu²⁺, Hg²⁺, Co²⁺, Cr²⁺ and Fe³⁺. (Figure 3.10.).

3.2. Cell Studying

The results of sensing event were encouraging to perform detection of exogenous HOCl in cellular media. To this purpose, human lung adenocarcinoma cells (A549) were used. Initially, cells seeded onto glass coverslips and incubated for 24 hours for their growth. Then, cells pre-treated with **ANT-DPP** (10 μ M) and incubated for 30 mins for localization of dye. The free probe which is not penetrated along the cell wall washed with PBS and HOCl (100 μ M) was added. After the incubation period, the fluorescence microscopy images were taken. As shown in Figure 3.1a., the pre-treated cells –contol experiment without HOCl- exhibited no remarkable fluorescence signal.

The presence of cells was also proved by bright field image. On the other hand, the cells displayed a significant fluorescent signal in the presence of exogenous HOCl. It is also important to note that the probe localized on the cytoplasm of the cells. From findings of imaging experiments, it concluded that the **ANT-DPP** is cell penetrable and provides the detection of exogenous HOCl in cellular media. In addition, **ANT-DPP** is not very toxic to the A549 cells which are showed healthy spread and adherent morphology.

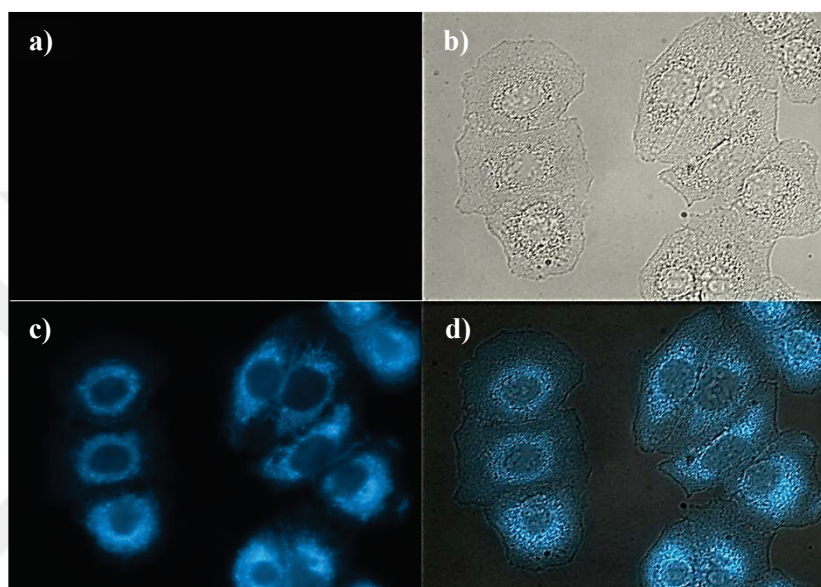

Figure 3.12. (a) Fluorescence image of human lung adenocarcinoma cells (A549) treated with only **ANT-DPP** (10 μ M) for 20 min; (b) Bright-field imaging (c) Cells treated with **ANT-DPP** and HOCl (100 μ M) (d) Merged image of b and c. (λ_{ex} : 380nm).

CHAPTER 4

CONCLUSION

In this study, an anthracene-based “turn on” probe for the selective and sensitive detection of hypochlorous acid was designed, synthesized and its sensor characteristics were examined by spectroscopic analysis and live cell imaging studies. Anthracene was selected as fluorophore moiety, diphenyl phosphine moiety was used as a receptor unit and acetylene used as a spacer. The probe, **ANT-DPP** quenched by PET mechanism which was cancelled in the presence of HOCl due to the oxidation of phosphine to phosphine oxide.

The photophysical properties of the probe were carefully scrutinized. **ANT-DPP** has no fluorescence emission ($\Phi_F=0.048$) because of the PET quenching -explained by the transfer of unpaired electrons of the phosphorus to fluorophore- upon excitation at 380 nm. The probe produced a significant turn on response ($\Phi_F=0.6$) centered at 480 nm after treatment with HOCl due to the cancellation of PET.

Optimization of the sensing event was studied carefully. All variables such as water content, pH, reaction time profile were cautiously studied. The optimum conditions were determined as 10 μ M dye concentration in CH₃CN/HEPES (1:1 (v/v), pH: 7.0). **ANT-DPP** was found to be selective to HOCl over other ROS and anions. In addition, it selectively detects HOCl even in the presence of other ROS/anions in the sensing medium.

Finally, the HOCl sensing event was performed in a biological system. The exogenous HOCl successfully detected inside the A549 cells by using **ANT-DPP**. It is important to note that **ANT-DPP** was cell permeable and homogeneously distributed in the cytoplasm of the cell.

REFERENCES

- Aruoma, O.I. 1998. "Free radicals, oxidative stress, and antioxidants in human health and disease." *Journal of the American Oil Chemists' Society*; 75(2):199-212.
- Barber, S.C.; Mead, R.J.; Shaw, P.J. 2006. "Oxidative stress in ALS: A mechanism of neurodegeneration and a therapeutic target." *Biochimica et Biophysica Acta - Molecular Basis of Disease*, February 2017, 387:95-10 November 2006, 1762(11-12):1051-1067.
- Bhattacharya, S. 2015. "Reactive Oxygen Species and Cellular Defense System. In: Rani V., Yadav U. (eds) Free Radicals in Human Health and Disease" *Springer, New Delhi*.
- Briegera, K.; Schiavonea, S.; Francis, J.M.; Krausea, K.-H. 2012. "Reactive oxygen species: from health to disease" *The European Journal of Medical Sciences*,; August 2012.
- Cheng, X.; Jia, H.; Long, T.; Feng, J.; Qin, J.; Li, Z. 2011. "A "turn-on" fluorescent probe for hypochlorous acid: Convenient synthesis, good sensing performance, and a new design strategy by the removal of CN isomerization." *Chemical Communications*, November 2011, 47(43):11978-11980.
- Clark, R.A. and Szot, S. 1981. "The myeloperoxidase-hydrogen peroxide-halide system as effector of neutrophil-mediated tumor cell cytotoxicity." *The Journal of Immunology*, April 1981, 126 (4) 1295-1301.
- Deng, S.; Chen, H.; Jepsen, S.; Dommisch, H.; Stiesch, M.; Eberhard, J.; Fickenscher, H.; Maser, E.2011. "Cysteine proteases from *Porphyromonas gingivalis* and TLR ligands synergistically induce the synthesis of the cytokine IL-8 in human artery endothelial cells." *Archives of Oral Biology*, December 2011, 56(12):1583-1591.
- De Silva, A.P.; Wright, G.D.; Moody, T.S.2009. "Fluorescent PET (Photoinduced Electron Transfer) sensors as potent analytical tools." *Analyst*, 2009, 134(12):2385-2393.

- Dukan, S.; Touati, D.; Belkin, S. 1999. "Reactive oxygen species are partially involved in the bacteriocidal action of hypochlorous acid." *Archives of Biochemistry and Biophysics*, July 1999, 367(2):311-316.
- Emrullahoğlu, M.; Üçüncü, M.; Karakuş, E. 2013. "A BODIPY aldoxime-based chemodosimeter for highly selective and rapid detection of hypochlorous acid." *Chemical Communications*, September 2013, 49(71):7836-7838.
- Gagné, F. 2014. 'Chapter 6: Oxidative Stress' in Gagné, F. et al. *Biochemical Ecotoxicology: Principles and Methods*. Elsevier, pp. 103-115.
- Griesbeck, A.G.; Warzecha, K.-D.; Hoffmann, N. 2007. "Photoinduced-electron-transfer chemistry: From studies on PET processes to applications in natural product synthesis." *Accounts of Chemical Research*, February 2007, 40(2):128-140.
- Heuft, M.A.; Collins, S.K.; Yap, G.P.A.; Fallis, A.G. 2001. "Synthesis of diynes and tetraynes from in situ desilylation/dimerization of acetylenes." *Organic Letters*, September 2001, 3(18):2883-2886.
- Hole, P. S.; Darley, R. L.; Tonks, A. 2011. "Do reactive oxygen species play a role in myeloid leukemias?" *Blood*, June 2011; 117; 22; p5816-p5826.
- Hu, J. J.; Ye, S.; Yang, D. 2017. "Fluorescent Probes for HOCl Imaging." *Israel Journal of Chemistry*. April 2017, Vol. 57 Issue 3/4, p251-258. 8p.
- Jeitner, T.M.; Kalogiannis, M.; Krasnikov, B.F.; Peltier, M.R.; Gomlin, I.; Moran, G.R. 2016. "Linking inflammation and parkinson disease: Hypochlorous acid generates parkinsonian poisons." *Toxicological Sciences*, 2016, 151(2):388-402.
- Kenmoku, S.; Urano, Y.; Kojima, H.; Nagano, T. 2007. "Development of a highly specific rhodamine-based fluorescence probe for hypochlorous acid and its application to real-time imaging of phagocytosis." *Journal of the American Chemical Society*, June 2007, 129(23):7313-7318.
- Knight, J.A. 1998. "Free radicals: Their history and current status in aging and disease." *Annals of Clinical and Laboratory Science*,; 1998, 28(6):331-346.

- Kulcharyk, PA; Heinecke, JW. 2001. "Hypochlorous acid produced by the myeloperoxidase system of human phagocytes induces covalent cross-links between DNA and protein." *Biochemistry*; March 2001; 40; 12; p3648-p3656.
- Malik B.; Pirzadah T.B.; Tahir I.; Rehman R.U.; Hakeem K.R.; Abdin M.Z. 2014. "Plant Signaling: Response to Reactive Oxygen Species. In: Hakeem K., Rehman R., Tahir I. (eds) Plant signaling: Understanding the molecular crosstalk." *Springer, New Delhi*.
- Mittler, R. 2017. "ROS Are Good." *In Trends in Plant Science*. January 2017 22(1):11-19.
- Ozougwu, J. C. 2016. "The Role of Reactive Oxygen Species and Antioxidants in Oxidative Stress" *International Journal of Research in Pharmacy and Biosciences*; Volume 3, Issue 6, pp 1-8.
- Peng, P.; Li, H.; Bai, L.; Wang, L.; Chen, B.; Yu, C.; Zhang, C.; Li, L.; Huang, W.; Ge, J. 2018. "Photocontrollable Fluorogenic Probe for Visualizing Near-Membrane Hypochlorite in Live Cells." *ChemistrySelect*, June 2018, 3(21):5981-5986.
- Pizzino, G.; Irrera, N.; Pallio, G.; Mannino, F.; Arcoraci, V.; Squadrito, F.; Bitto, A.; Cucinotta, M.; Altavilla, D. 2017. "Oxidative Stress: Harms and Benefits for Human Health" *Oxidative Medicine and Cellular Longevity*.
- Ponnuvel, K.; Ramamoorthy, J.; Padmini, V.; Sivaraman, G. 2018. "Merocyanine dye-based fluorescent chemosensor for highly selective and sensitive detection of hypochlorous acid and imaging in live cells." *ChemistrySelect*, 2018, 3(1):91-95.
- Prasad, S.; Gupta, S.C.; Tyagi, A.K. 2017. "Reactive oxygen species (ROS) and cancer: Role of antioxidative nutraceuticals." *Cancer Letters*,; February 2017, 387:95-105.
- Pullar, JM; Vissers, MCM; Winterbourn, CC. "Living with a killer: The effects of hypochlorous acid on mammalian cells." *Iubmb Life*; 2000; 50; 4-5; p259-p266.

- Sam, C.-H.; Lu, H.-K., 2009. "The role of hypochlorous acid as one of the reactive oxygen species in periodontal disease." *Journal of Dental Sciences*, June 2009, 4(2):45-54.
- Setsukinai, K; Urano, Y; Kakinuma, K; Majima, HJ; Nagano, T. 2003. "Development of novel fluorescence probes that can reliably detect reactive oxygen species and distinguish specific species." *Journal of Biological Chemistry*; January 2003; 278; 5; p3170-p3175.
- Shen, Y.; Zhang, X.; Wen, S.; Liu, M.; Deng, Y.; Zhang, C.; Jin, J.; Huang, X.; Zhang, Y.; Li, H.; Yao, S.2015. "A simple and reversible fluorescent probe based on NBD for rapid detection of hypochlorite and its application for bioimaging." *RSC Advances*, September 2015, 5(97):79519-79524.
- Sun, Z.-N.; Yang, D.; Liu, F.-Q.; Chen, Y.; Tam, P.K.H. 2008. "A highly specific BODIPY-based fluorescent probe for the detection of hypochlorous acid." *Organic Letters*, June 2008, 10(11):2171-2174.
- Taniyama, Y; Griendling, KK. 2003. "Reactive oxygen species in the vasculature - Molecular and cellular mechanisms." *Hypertension*; December 2003; 42; 6; p1075-p1081.
- Turrens, JF. 2003. "Mitochondrial formation of reactive oxygen species." *Journal Of Physiology*; October 2003; 552; 2; p335-p344.
- Villamena, F.A. 2017. "Chapter 2 - Chemistry of Reactive Species. In: Fluorescence to Electron Paramagnetic Resonance Spectroscopy." *Reactive Species Detection in Biology*, Pages 13-64.
- Vyas, P.V.; Bhatt, A.K.; Ramachandraiah, G.; Bedekar, A.V.. "Environmentally benign chlorination and bromination of aromatic amines, hydrocarbons and naphthols." *Tetrahedron Letters*, May 2003, 44(21):4085-4088.
- Yang, Y. (2009). Mechanism and inhibition of hypochlorous acid-mediated cell death in human monocyte-derived macrophages: A thesis submitted in partial fulfilment of the requirements for the degree of Doctor of Philosophy in Biochemistry at the University of Canterbury, New Zealand (Unpublished master's thesis).

- Wang, B.; Wen, J.; Yan, H.; Xu, Y.; Li, H.; Sun, S.; Gao, K.; Chen, J.; Wang, W. 2016. "Double-mode detection of HClO by naked eye and concurrent fluorescence increasing in absolute PBS." *RSC Advances*, 2016, 6(42):35315-35317.
- Wang, H.-S. 2016. "Development of fluorescent and luminescent probes for reactive oxygen species." *Trends in Analytical Chemistry*; December 2016, 85:181-202.
- Williams, R. M. 1996. "Introduction to electron transfer" PhD Thesis, University of Amsterdam, Chapter 1, pp. 12-16.
- Winterbourn, C.C. 2008. "Reconciling the chemistry and biology of reactive oxygen species." *Nature Chemical Biology*; March 2008, 4(5):278-286.

APPENDIX A

^1H NMR, ^{13}C NMR AND ^{31}P SPECTRUMS OF COMPOUNDS

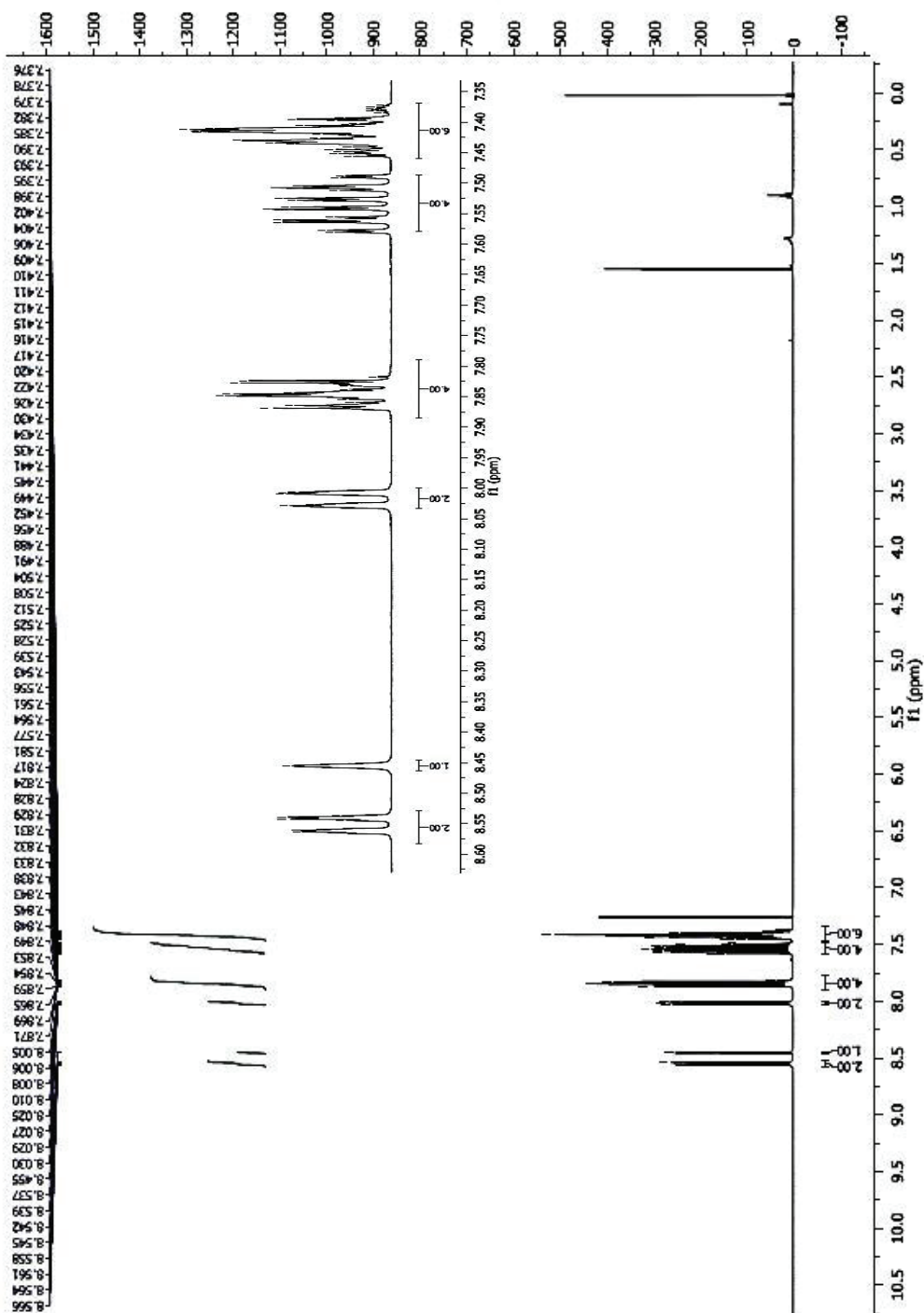

Figure A 1. ^1H NMR of ANT-DPP

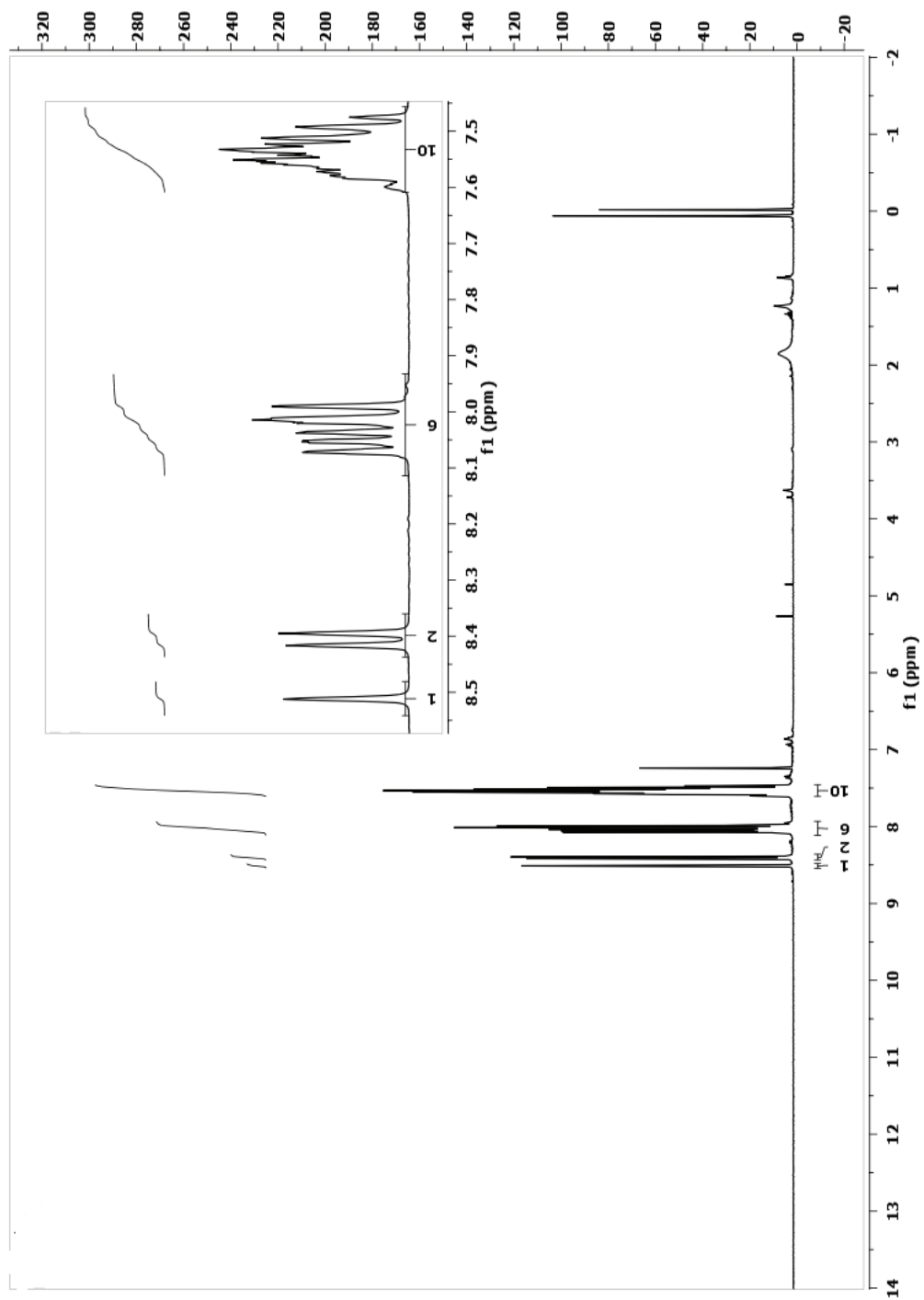

Figure A 2. ^1H NMR of ANT-DPPO

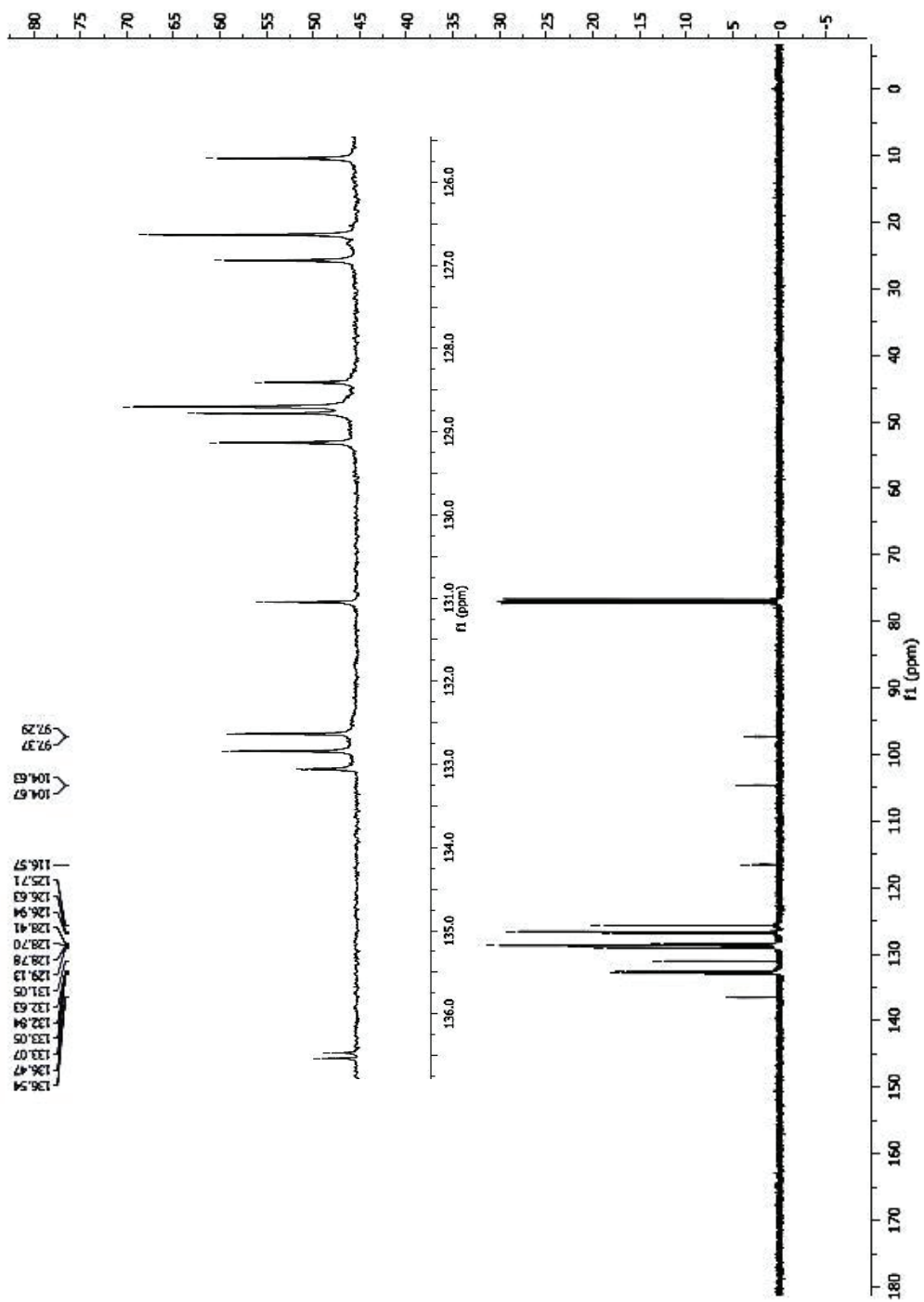

Figure A 3. ^{13}C NMR of ANT-DPP

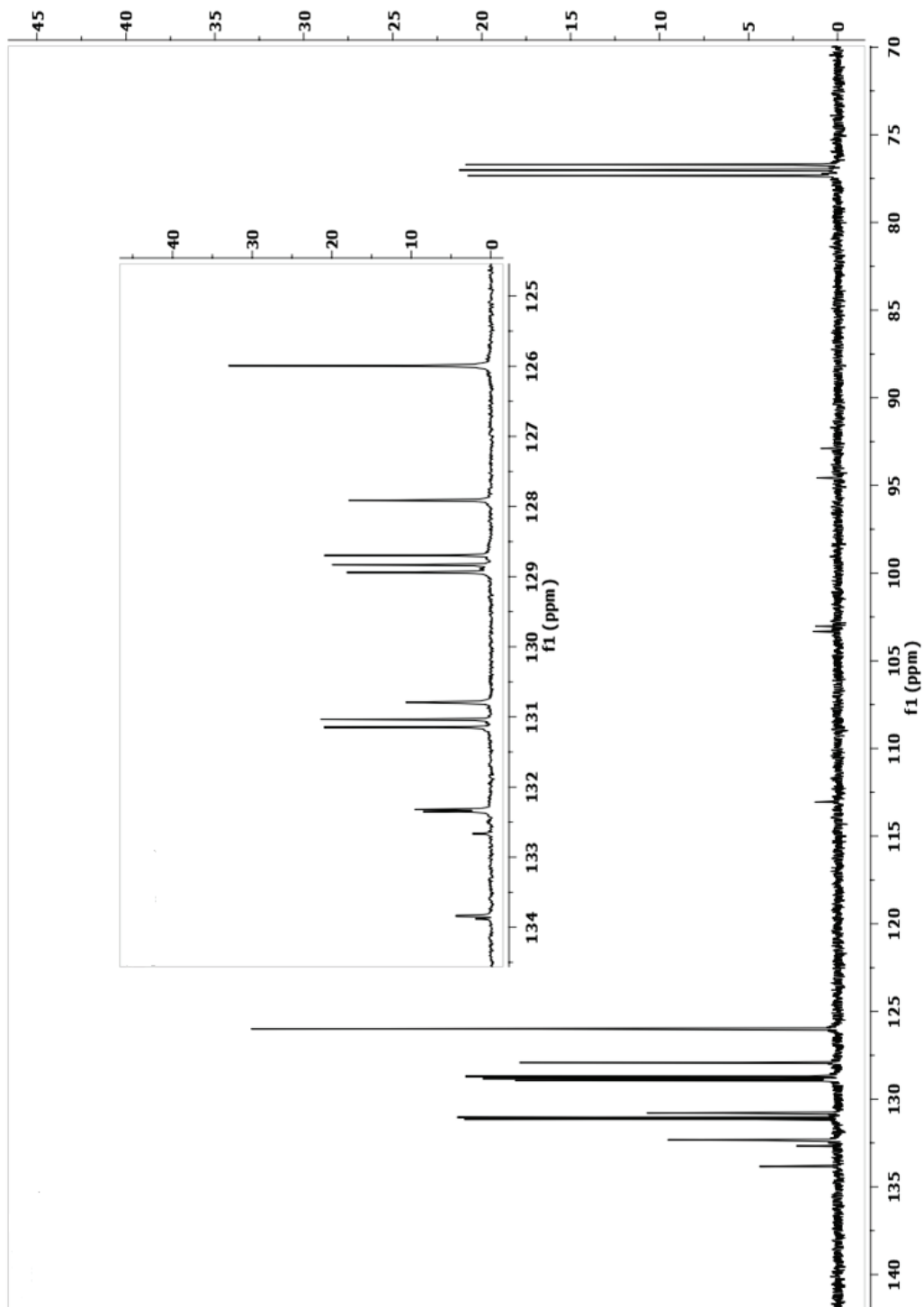

Figure A 4. ^{13}C NMR of ANT-DPPO

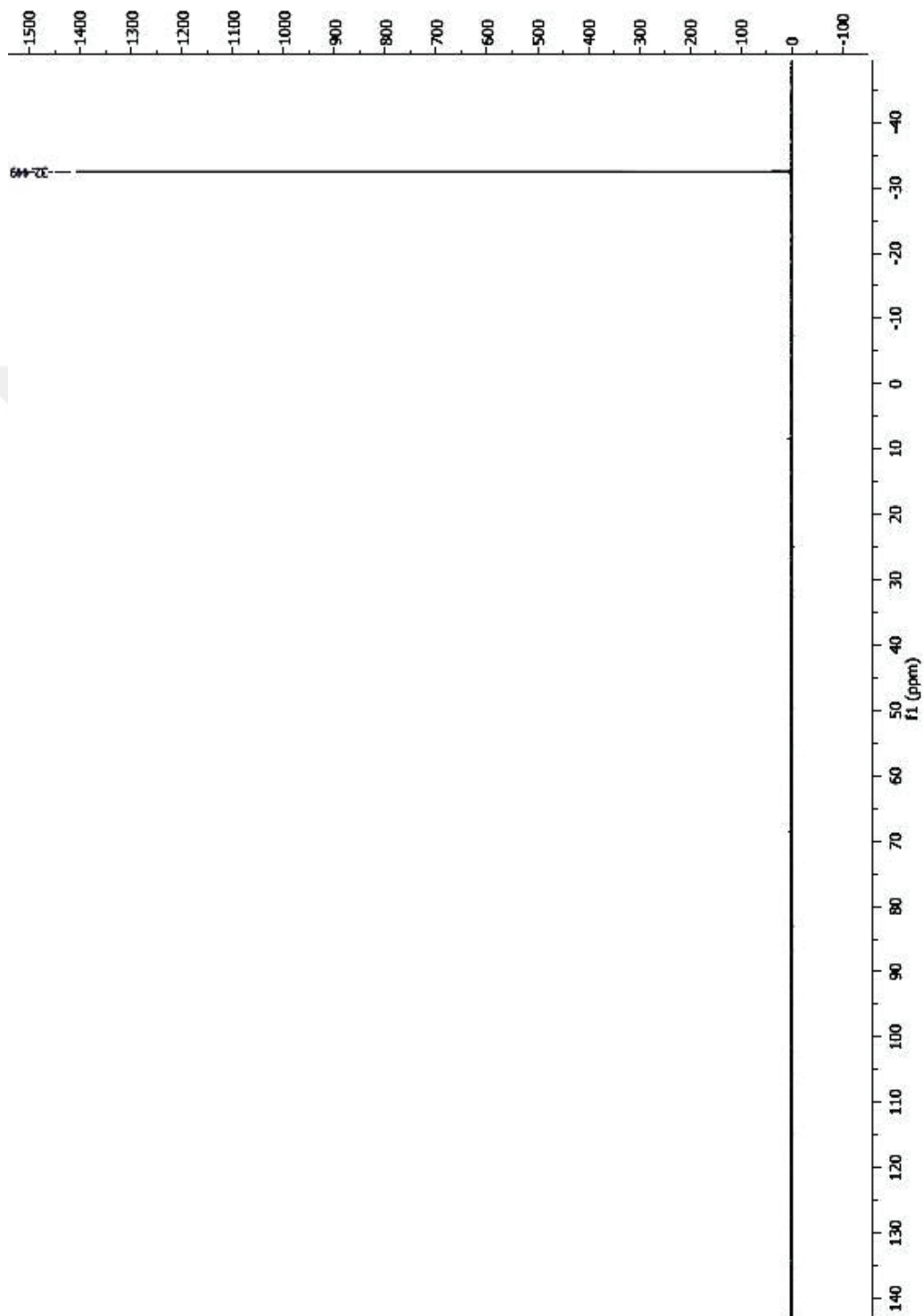

Figure A 5. ^{31}P NMR of ANT-DPP

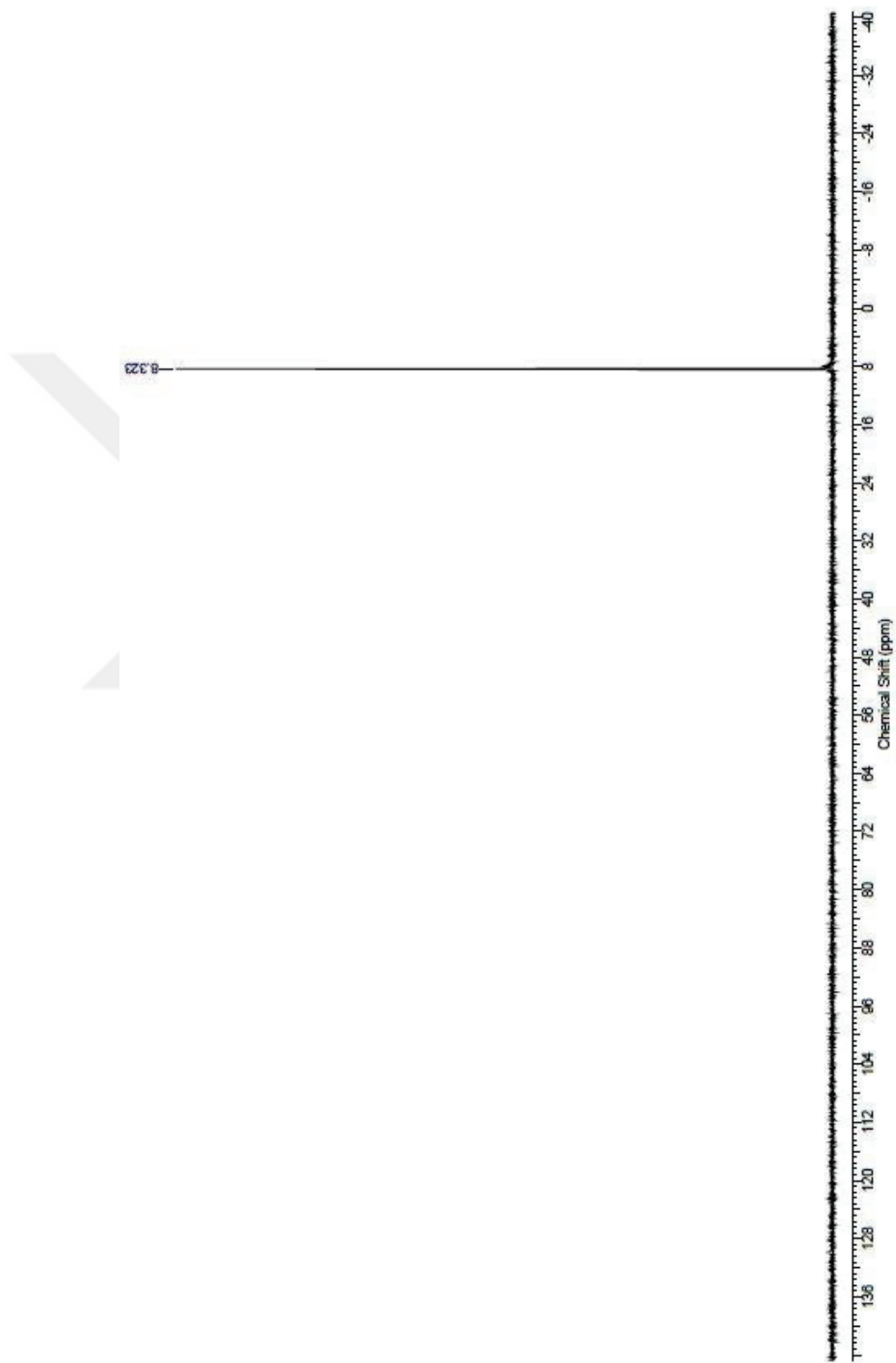

Figure A 6. ^{31}P NMR of ANT-DPPO

APPENDIX B
MASS SPECTRA OF COMPOUNDS

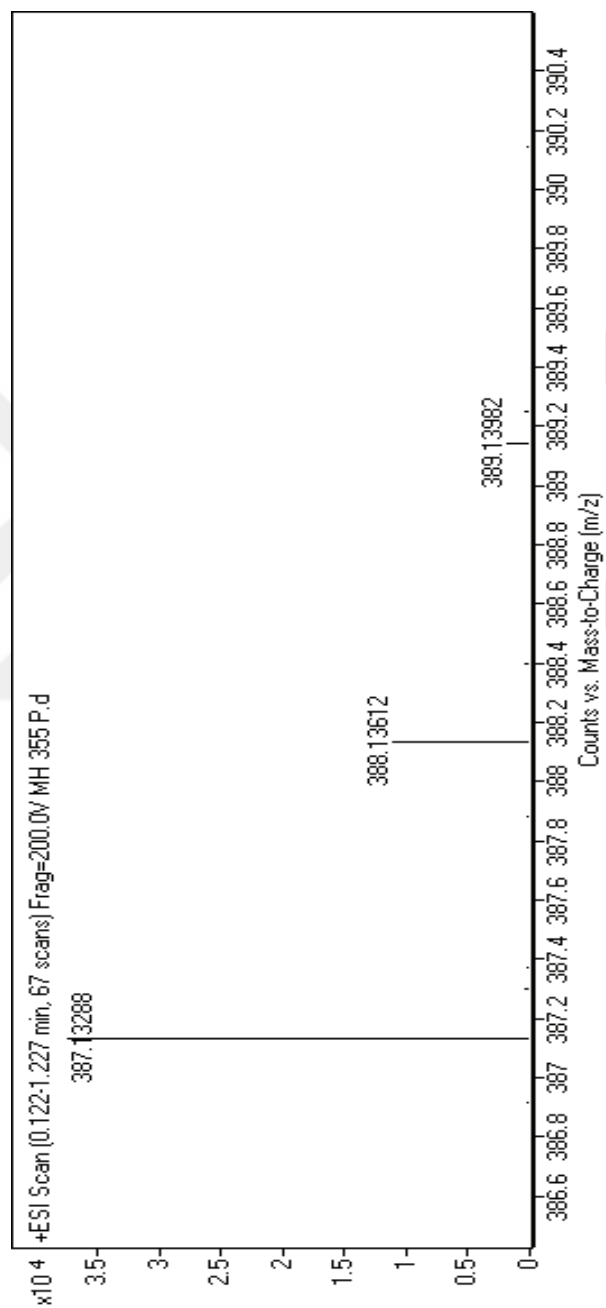

Figure B 1. HRMS of ANT-DPP

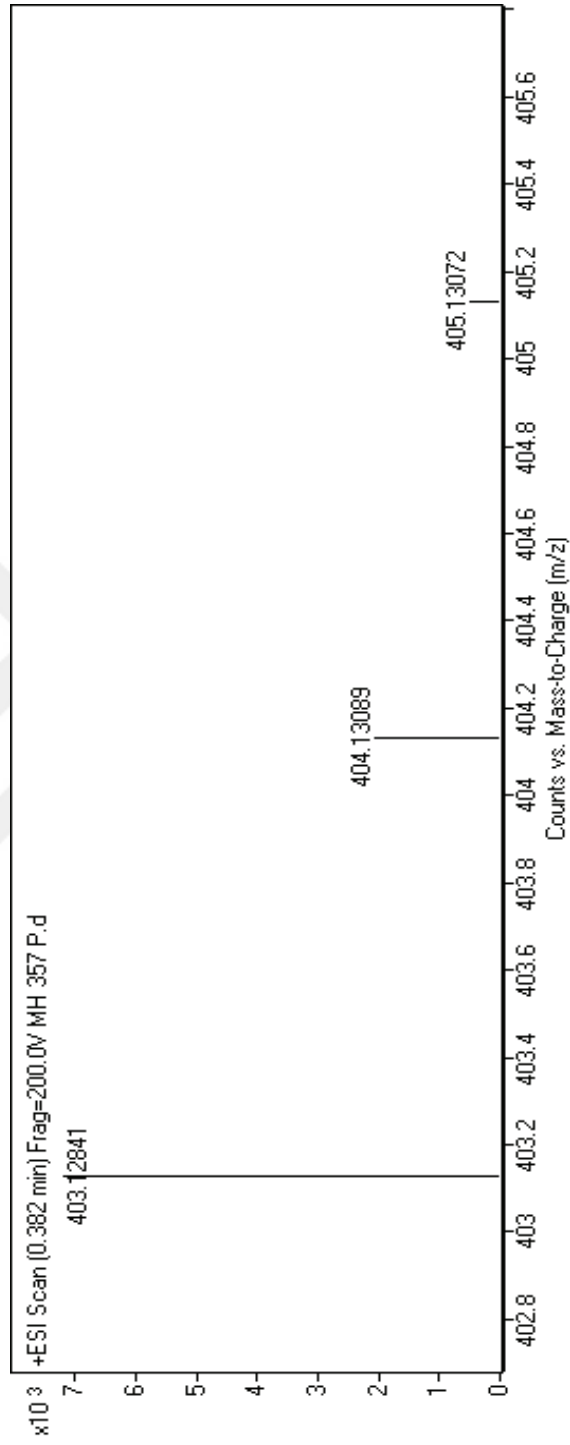

Figure B 2. HRMS of ANT-DPPO