

SOME OBSERVATIONS ON THE SEISMIC BEHAVIOUR OF
TRADITIONAL TIMBER STRUCTURES IN TURKEY

A THESIS SUBMITTED TO
THE GRADUATE SCHOOL OF NATURAL AND APPLIED SCIENCES
OF
MIDDLE EAST TECHNICAL UNIVERSITY



BY

ASLI ER AKAN

IN PARTIAL FULFILLMENT OF THE REQUIREMENTS FOR THE DEGREE OF
MASTER OF SCIENCE
IN
ARCHITECTURE

JUNE 2004

Approval of the Graduate School of Natural and Applied Sciences

Canan Özgen

Prof. Dr. Canan Özgen
Director

I certify that this thesis satisfies all the requirements as a thesis for the degree of Master of Science

S. Öner

Assoc. Prof. Dr. Selahattin Öner
Head of Department

This is to certify that we have read this thesis and that in our opinion it is fully adequate, in scope and quality, as a thesis for the degree of Master of Science.

Ali İhsan Ünay

Assoc. Prof. Dr. Ali İhsan Ünay
Supervisor

Examining Committee Members

Dr. Erhan Karaesmen

Asst. Prof. Dr. Ahmet Türer

Dr. Ünal İlker

Part. Time. Inst. Joseph Kubin

Assoc. Prof. Dr. Ali İhsan Ünay

Joseph Kubin
Ali İhsan Ünay
Ali İhsan Ünay
Ali İhsan Ünay

NOT APPROVED DUE TO
THE CONCEPTUAL MISTAKES
INVOLVED,

I hereby declare that all information in this thesis document has been obtained and presented in accordance with academic rules and ethical conduct. I also declare that, as required by these rules and conduct, I have fully cited and referenced all material and results that are not original to this work.

Name, Last name: Asli Er Akan

Signature

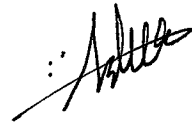

ABSTRACT

SOME OBSERVATIONS ON THE SEISMIC BEHAVIOUR OF TRADITIONAL TIMBER STRUCTURES IN TURKEY

ER AKAN, ASLI

Ms., Department of Architecture

Supervisor: Assoc. Prof. Dr. Ali İhsan Ünay

June 2004, 108 pages

This thesis is about behaviour of traditional timber structures under lateral loads in Turkey. The timber-framed houses are the products of cultural heritage of people who live in Anatolia. These structures have performed well in earthquakes throughout the history. As a result, this study intends to present the observations on the seismic behaviours of traditional timber buildings with the help of computer-generated models. In this thesis, the general characteristics of timber are examined, the earthquake problem is briefly introduced, its effects on buildings are discussed, current knowledge on the earthquake performance of traditional Turkish timber buildings is presented, and their seismic behaviours are shown by using SAP2000 to help to better understand their behaviours in an earthquake.

Keywords: Characteristics of Timber, Traditional Timber Buildings, Seismic Behaviour of Timber Structures, Himiş and Bağdadi Type Structures.

ÖZ

TÜRKİYE'DEKİ GELENEKSEL AHŞAP YAPILARIN DEPREME İLİŞKİN DAVRANIŞLARI ÜZERİNE BAZI GÖZLEMLER

ER AKAN, ASLI

Yüksek Lisans, Mimarlık Bölümü

Tez Yöneticisi: Doç. Dr. Ali İhsan Ünay

Haziran 2004, 108 sayfa

Bu tez Türkiye'deki geleneksel ahşap yapıların yanal yükler altındaki davranışını araştırmaktadır. Ahşap iskeletli evler Anadolu'da yaşayan insanların kültürel mirasının bir ürünüdür. Bu yapılar tarih boyunca depremlerde iyi bir performans sergilemişlerdir. Sonuç olarak bu çalışma bilgisayar destekli modellemelerin yardımı ile geleneksel ahşap binaların depreme ilişkin davranışını göstermeyi amaçlamaktadır. Bu tezde ahşabın genel özellikleri incelenmekte, deprem kısaca tanımlanmakta, depremin binalar üzerindeki etkisi tartışılmakta, geleneksel Türk ahşap binalarının depreme karşı performanslarının güncel bilgileri sunulmakta ve bu yapıların depremdeki davranışlarını daha iyi anlayabilmek için SAP2000 kullanarak sismik davranışları gösterilmektedir.

Anahtar Kelimeler: Ahşabın Özellikleri, Geleneksel Ahşap Binalar, Ahşap Yapıların Depreme İlişkin Davranışları, Hımış ve Bağdadi Yapılar.



To My Family

ACKNOWLEDGEMENTS

I express my sincere appreciation to Dr. Erhan Karaesmen and my supervisor Dr. Ali İhsan Ünay for their helpful guidance and their insight throughout the research. I also would like to convey my thanks to Kemal Gülçen for his priceless contribution. Thanks also to, inhabitants of Gölyaka for their valuable help, which made the field possible.

I also thank to my parents for their support throughout all my life. To my husband, Volkan, thanks for his moral and tolerant support, great patience and understanding.

TABLE OF CONTENTS

ABSTRACT.....	iv
ÖZ.....	v
ACKNOWLEDGEMENTS.....	vii
TABLE OF CONTENTS.....	viii
LIST OF TABLES.....	xi
LIST OF FIGURES.....	xii
CHAPTER	
1. INTRODUCTION.....	1
1.1 Problem Definition.....	1
1.2 Objectives and Scope of the Research.....	4
1.3 Methodology.....	5
2. GENERAL CHARACTERISTICS OF STRUCTURAL TIMBER.....	6
2.1 Physical Characteristics of Timber.....	6
2.2 Biological Characteristic of Timber.....	9
2.3 Chemical Characteristic of Timber.....	11
2.4 Structural Characteristic of Timber.....	12
2.5 Advantages of Timber as a Building Material.....	13
2.6 Disadvantages of Timber as a Building Material.....	15
3. TRADITIONAL TIMBER BUILDINGS IN TURKEY.....	16
3.1 Brief History of Timber Structures.....	16
3.2 Traditional Timber Material.....	23
3.3 Construction Systems of Traditional Turkish Wooden Houses.....	24
3.3.1 Foundations.....	25

3.3.2 Floors.....	29
3.3.3 Timber Framed Systems.....	35
3.3.3.1 Hırmış.....	40
3.3.3.2 Bağdadi.....	45
3.3.4 Wood Block System.....	47
3.3.4.1 Simple Wood Block System with Round Logs.....	47
3.3.4.2 Wood Block System with Rafters...	49
3.3.5 Roofs.....	51
4. THE BEHAVIOUR OF TRADITIONAL TIMBER BUILDINGS AGAINST EARTHQUAKE.....	54
4.1 Definition of the Earthquake Phenomenon.....	54
4.2 Seismic Effects on Structures.....	57
4.2.1 Inertia Forces in Structures.....	57
4.2.2 Effect of Deformations in Structures....	58
4.2.3 Horizontal and Vertical Shaking.....	59
4.2.4 Flow of Inertia Forces to Foundation....	59
4.3 Observations on Behaviours of Traditional Timber Buildings in Past Earthquakes.....	60
4.3.1 Traditional Timber Building in the Kocaeli Earthquake of August 17, 1999.....	66
4.3.2 Traditional Timber Building in the Düzce Earthquake of November 12, 1999.....	69
4.3.3 Traditional Timber Building in the Sultandağı-Çay Earthquake of February 3, 2002.....	72

5. EFFECTS OF LATERAL FORCES ON TRADITIONAL TIMBER BUILDINGS: A CASE STUDY.....	76
5.1 The Objective of the Study.....	76
5.2 Definition of the Computer Analysis Technique.....	76
5.3 Definition of the Case Studies.....	77
5.4 Computer Models of the Case Studies.....	82
6. CONCLUSIONS.....	94
REFERENCES.....	97
APPENDICES.....	103
A MAJOR EARTHQUAKES OF 20 TH CENTURY.....	103
B SEISMICITY OF TURKEY.....	106

LIST OF TABLES

TABLE

Table 3.1	Functions of Timber Frame Members.....	36
Table 3.2	Functions of The Traditional Roof Members.....	51
Table 5.1	Summary of the Structural Analysis.....	93
Table A.1	Major Earthquakes of 20 th Century.....	103
Table A.2	Major Earthquakes in Turkey between 1509 and 2002.....	105



LIST OF FIGURES

FIGURE

Figure 2.1 Typical Stress-Strain Curves for Wood, Steel and Concrete.....	7
Figure 2.2 Macrostructure Of Timber.....	10
Figure 2.3 Microstructure Of Timber.....	11
Figure 3.1 Turkish Wooden Houses According To Region.....	18
Figure 3.2 Types Of Wall Infill Systems.....	19
Figure 3.3 Types Of Wall Infill Systems.....	20
Figure 3.4 Examples of Traditional Turkish Wooden Houses.....	21
Figure 3.5 Examples of Single Foundation.....	26
Figure 3.6 Examples of Continuous Foundation.....	27
Figure 3.7 Masonry Foundations with Reinforced Concrete Footing and Lintel According to Turkish Building Regulation.....	28
Figure 3.8 An Example of Composite Foundation from Mudurnu.....	29
Figure 3.9 Floor Construction Types.....	31
Figure 3.10 Upper Floor Construction Types.....	33
Figure 3.11 Floor Construction in Timber Framed Section.....	34
Figure 3.12 Double Layered Floor Type.....	34
Figure 3.13 Members Of Timber Framed System.....	36
Figure 3.14 Connection of Braces.....	39
Figure 3.15 Hımış Structures From Different Cities.....	41
Figure 3.16An Example of Hımış Structure with Brick Infill from Düzce.....	42
Figure 3.17 Traditional Timber Buildings with Sun-Dried Brick Fill....	43
Figure 3.18 Traditional Timber Buildings with Stone Fill.....	44

Figure 3.19 Examples of Bağdadi Structures.....	46
Figure 3.20 Simple Wood Block System.....	48
Figure 3.21 Wood Block System with Rafters.....	49
Figure 3.22 A Serender in East Black Sea Region.....	50
Figure 3.23 Traditional Roof Construction.....	53
Figure 4.1 Earthquake Photos from Different Cities.....	56
Figure 4.2 Effect Of Inertia In A Building When Shaking At Its Base.....	57
Figure 4.3 Inertia Force and Relative Motion within a Building.....	58
Figure 4.4 Flow of Seismic Inertia Forces Through All Structural Components.....	60
Figure 4.5 Intervals Between Window And Door.....	63
Figure 4.6 X Bracing.....	66
Figure 4.7 Epicenter of Kocaeli Earthquake.....	67
Figure 4.8 Hımiş Structures After Earthquake.....	68
Figure 4.9 Epicenter of Düzce Earthquake.....	70
Figure 4.10 Hımiş Structures After Earthquake.....	71
Figure 4.11 Sultandağı Fault Zone.....	72
Figure 4.12 Damage Distribution of Sultandağı Earthquake.....	73
Figure 4.13 Traditional Building Damages in Sultandağı Earthquake...	74
Figure 5.1 The Map of Gölyaka.....	78
Figure 5.2 The Fault Lines Around Gölyaka.....	79
Figure 5.3 Some examples of traditional structures from Gölyaka.....	80
Figure 5.4 The Case Study.....	81
Figure 5.5 Construction Systems of Hımiş and Bağdadi Structures...	84
Figure 5.6 Undeformed Shape of Hımiş Structure Without Infill Material	85
Figure 5.7 Undeformed Shape of Hımiş Structure With Infill Material	85
Figure 5.8 Deformed Shape of Hımiş Type of Building.....	86

Figure 5.9 Deformed Shape of Hımıř Type of Building.....	86
Figure 5.10 Typical Moment Diagram of Hımıř Structure Under Lateral Forces.....	87
Figure 5.11 Typical Axial Force Distribution of Hımıř Structure Under Lateral Forces.....	87
Figure 5.12 Undeformed Shape of Bađdadi Type Building Without Infill.....	88
Figure 5.13 Undeformed Shape of Bađdadi Type Building Without Infill.....	88
Figure 5.14 Deformed Shape of Bađdadi Structure Without Infill.....	89
Figure 5.15 Deformed Shape of Bađdadi Structure Without Infill.....	89
Figure 5.16 Typical Moment Diagram of Bađdadi Structure Without Infill Under Lateral Forces.....	90
Figure 5.17 Typical Axial Force Distribution of Bađdadi Structure Without Infill Under Lateral Forces.....	90
Figure 5.18 Deformed Shaped of Bađdadi Type Building With Infill...	91
Figure 5.19 Deformed Shaped of Bađdadi Type Building With Infill...	91
Figure 5.20 Typical Moment Diagram of Bađdadi Structure With Infill Under Lateral Forces.....	92
Figure 5.21 Typical Axial Force Distribution of Bađdadi Structure With Infill Under Lateral Forces.....	92
Figure 5.22 Deformation in Hımıř Structure.	93
Figure B.1 Seismic Plates Around Turkey and Seismic Faults In Turkey.....	108

CHAPTER I

INTRODUCTION

Problem Definition

Among the natural hazards faced by humans on earth, earthquakes are probably one of the most disastrous actions. Many of the heavily populated regions of the world are in seismically active regions. Turkey is located on one of the most active earthquake areas on earth called Alp-Himalayan Seismic Belt as mentioned by Özmen (2002). Therefore numerous big scale earthquakes have happened in Turkey throughout the history. The latest ones Marmara and Düzce Earthquakes occurred in magnitudes 7.4 MW and 7.2 MW, respectively as stated by Erdik (1999). These earthquakes have turned into catastrophe by the collapse of structures. The occurrence of an earthquake results not only in material damage but also in substantial loss of life. Because earthquakes as natural phenomena are unpreventable, the only course of actions for engineers and architects is to build seismically resistant structures. These structures should be designed to resist forces and do not collapse when subjected to earthquake.

Understanding of the behaviour of a structure during an earthquake is the first step required in a design of earthquake resistant structures. Experiences from past earthquakes show that traditional timber structures carefully designed exhibit good performance. This seeks to answer some questions such as which characteristics of these buildings provide earthquake

resistance. According to Tarabia (1994) this is due to a number of factors, particularly the high strength-to-weight ratio of timber as a material, due to its enhanced strength under short term loading and due to the ability to dissipate large amount of energy without collapsing. In addition to these characteristics of timber, for being both light and resistant to tensile stress, it can cover considerable spans. More detailed information about physical and mechanical properties of timber is provided in Chapter II.

Timber has always had an important role in house construction in every region of Anatolia. However, despite the qualities and advantages, traditional timber construction systems are not used for building today. Unfortunately this construction system has already lost. This apparent reluctance of using timber structures in seismic regions is often influenced by the lack of adequate research. In addition, very little attention is given to earthquake behaviour of traditional timber structures. In the article of Nakagawa and Ohta (2003), they show the collapsing process simulations of timber structures under dynamic loading. They use a newly developed EDEM (the efficacy of the extended distinct element method) modelling method for analysis of timber-framed systems. With these analyses they indicated that the frame models with different shear wall configurations collapse in different ways.

A limited amount of information is currently available on the seismic behaviour of timber frames. In general, the static and cyclic behaviour of bolted connections and braced timber frames have been studied in Canada. In addition to Canada, in United States, Britain and Australia timber shows a great development in terms of construction techniques.

After the earthquakes in 1999 in Turkey, surveys indicated that several traditional timber buildings have remained intact whereas the others built

with today technology have collapsed. Langenbach (2000) points out that many people make the mistake of thinking that it is only our generation, which has discovered ways of resisting the threat of earthquakes in structural design. They come to believe that older forms of construction practice must be more dangerous simply because they were designed before current engineering knowledge about earthquakes had been developed. In Kashmir, an elaborate system of interlocking horizontal timber runner beams was used, without vertical wood columns, to hold the rubble masonry and soft mud mortar buildings together on the silty soil. Historical reports confirm that these buildings withstood earthquakes better than the nearby unreinforced brick palace.

Consequently there are many historical examples from which the designers and engineers can learn crucial hints about earthquake resistance. Some of these historical examples are traditional Turkish housing systems. Karaesmen (2002) has classified traditional timber framed construction systems in two groups: *hımış* and *bağdadi*. Detailed information about these systems is given in chapter III. Seismic characteristics and load bearing capacities of *hımış* and *bağdadi* structures are different from each other. *Bağdadi* structures are more resistant against earthquake compared to *hımış* structures as stated by Karaesmen (1970). The analysis of these structures are done in Chapter V. Results of the studies about this subject indicate that it is important to learn from the traditional construction techniques. Therefore new earthquake resistant constructions can be built by using some of the properties of these significant examples.

1.2. Objectives and Scope of the Research

Up to now the traditional timber structures in Turkey has been examined in many studies. However, this thesis concentrates on different aspect of this subject that is the some observations on the seismic behaviours of traditional timber structures in Turkey. The overall goals of this study are to examine characteristics of traditional timber construction techniques and to indicate the observations on the seismic behaviours of these systems. In order to determine earthquake behaviour of the traditional timber structures, SAP90 and SAP 2000 has been used in the analysis. The study also aims to be a reference work on construction systems and lateral load resistance of traditional Turkish timber structures.

After the introduction of this study, the research is continued with the second Chapter that has six sections named as Physical, Biological, Chemical, and structural Characteristics of Timber, Advantages and Disadvantages of Timber as a Building Material. In Chapter III, there are three sections, which are Brief of Timber Structures, Traditional Timber Materials and Construction Systems of Traditional Wooden Houses. Foundations, floors, construction systems and roofs of the timber structures are investigated in the last one. Then, Behaviour Of Traditional Timber Buildings Against Earthquake is examined in Chapter IV. This chapter consists of three sections named as Definition of Earthquake Phenomenon, Seismic Effects on Structures, and Behaviour of Traditional Timber Buildings in Past Earthquakes. After this chapter, study is continued with Chapter V, in which The Effect of Earthquakes on The Traditional Timber Structures: A Case Study is examined. This Chapter consist of five sections. Firstly, two sections describe The Objective of This Part of The Study and Definition of the Computer Analysis Technique. Afterwards Definition of

the Case Studies is presented. Two case studies constructed with bađdadi and himiř techniques have been chosen from Glyaka. Computer models of these cases are shown in the fifth section. Lastly, in Chapter VI conclusion of the study is given.

1.3. Methodology

The main theme in this thesis is the survey of earthquake behaviour of traditional Turkish timber structures. The research for the traditional structures and earthquake is obtained from the documents, which are written in Turkish language and written in English. Nevertheless, they are not enough to have required information therefore a field study has been also conducted. Traditional timber buildings especially in earthquake zones such as Dzce, Bolu, Mudurnu, Gynk, Glyaka, Rize, Safranbolu and Bartın are investigated. Different characteristics of those houses are observed according to region. Ultimately, Glyaka has been chosen for the case study, which consists of analysis of two different construction types of traditional timber structures with SAP 2000 software package. Drawings, illustrations, photos, tables are used to support the written sources.

CHAPTER II

GENERAL CHARACTERISTICS OF STRUCTURAL TIMBER

In the nature, wood is a perfect framework for trees to support fruits and leaves against to the gravity and wind forces. Similarly, because of these natural structural properties, timber is an ideal material to use in man-made constructions.

Wood is an abundant and user-friendly material and it is different from most other engineering materials in that user has little influence on its material properties. When used conveniently, this material is cost efficient for a variety of structures such as large span roof structures, bridges, residential office or industrial buildings. Since less energy needed for the construction of wood, this material is not only economical but also environment-friendly tool.

2.1 Physical Characteristic of Timber

The crucial properties of the timber are firstly its deformation on account of moisture and effect of microorganism. Secondly it has high heat and noise isolation value. Moreover timber is resistant against atmosphere and chemical effect and it has different resistance value according to fiber

direction. Lastly having a different tension-deformation curve because of its fiber tissue is an important characteristic of timber.

A linear relationship between stress and strain is an indicator of elastic behaviour (the return of a material to its original shape after being stressed and then un-stressed). Structures are expected to behave elastically under loads. Typical stress-strain curves for wood, steel and concrete are shown in Figure 2.1.

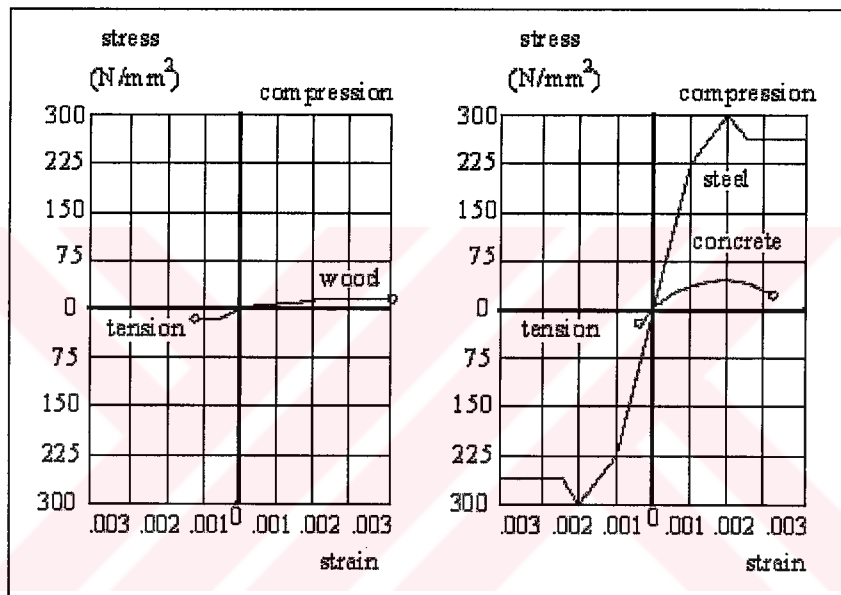

Figure 2.1 Typical Stress-Strain Curves for Wood, Steel and Concrete
<http://people.cornell.edu/pages/jo24/cuhk/courseNotes/timber/timber.html>

Moisture Effect: Moisture lessens the resistance of timber. Moisture content is defined as percentage of the oven dry weight of wood, thus wet or 'green' timber can have a moisture content of more than 100%. As the wood dries out, water first leaves the cell voids and when these are empty the moisture content of the wood is about 28%. This is known as the fibre saturation point since water is still bound into the cell walls. Wood loses (or

gains) moisture until it is in equilibrium with the moisture in the surrounding air. The equilibrium moisture content of timber will vary as the humidity of the air changes, but at a much slower rate. This is known as movement.

(www.timberbestpractice.org.uk/tbpp/ATR/PRODUCTS/f_struct7.htm)

Effects of Temperature and Noise: Wood substance is composed almost entirely of organic matter. The structural components consist of cellulose, hemicelluloses and lignin. Because of its air gap tissue and cellulosed structure, it does not allow heat and cold to pass the wall. It has more heat isolation especially in the perpendicular direction to fibres.

Effects of Microorganism: Insects, which are nourished with cellulose and lignin that constitute the tissue of timber, cause deterioration in this material. Hot weather, moisture and darkness increase insect's influence.

Atmosphere and Chemical Effects: Timber turns black by the effect of sun and exposes to chemical decomposition by the high heat as mentioned by Çobancaoğlu (1998:25). Speed of the reaction changes in relation with cross-section of the material, moisture and the amount of resin. Since wood can burn easily, some precautions must be taken before using timber for a construction material.

Mechanic Properties of Timber: Timber has high resistance and it is a light material because of its air gap tissue and fibre structure. The resistance of timber against tension is known as a result this provides to determine how timber can be designed under various forces. Resistance is higher in the parallel direction of fibres than it is in the perpendicular direction.

2.2 Biological Characteristic Of Timber

Botanical Properties of Timber: In the aspect of botanic timber, which is obtained from plant with woody, branch and root, is a rigid and fibrous material. Plants from which timber is obtained have some common properties: they are veined, old and their leaves change but their roots and trunks do not and also they have primary and secondary growing up.

Macrostructure of timber: It can be seen easily and sensed. In Figure 2.2 macrostructure of timber can be seen (Çobancaoğlu, 1998:22). Properties of macrostructure of timber are:

- Timber is obtained from vertical trees and symmetrical in the direction of diameter.
- It has cellular structure.
- Its anatomical structure shows diversity, according to species and growing conditions of tree.
- Water-sucker and vulnerable to attack of organisms.

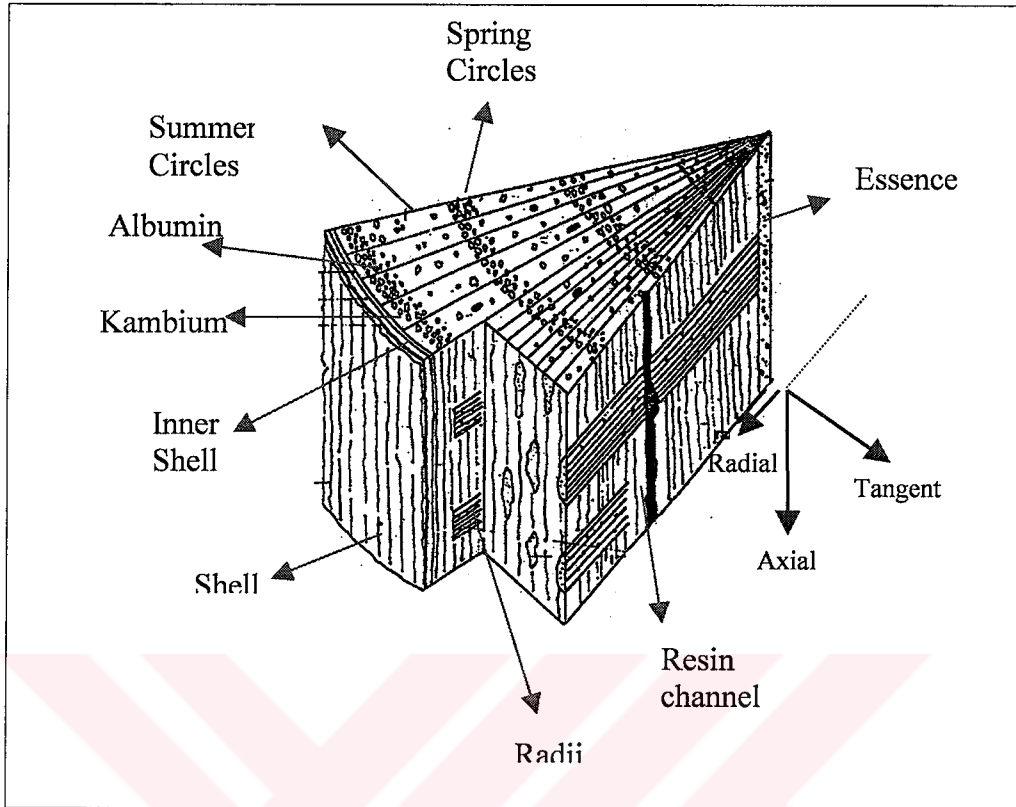

Figure 2.2 Macrostructure Of Timber
(Modified from Çobancaoğlu, 1998:22)

Microstructure of timber: Timber is composed of a bunch of small pipes that are arranged as coaxial circles and therefore its resistance increases in the direction of fibres, adversely decrease in the vertical direction of fibres as shown by Çobancaoğlu (1998:22) in Figure 2.3. In addition, its resistance is affected from winds, climate, land, and density of trees in the forest, some diseases, knots, defection of growing, cutting and utilization age. In the cross-section of a tree resistance increases from essence to shell, since the whole of the tree from root to end resistance decreases.

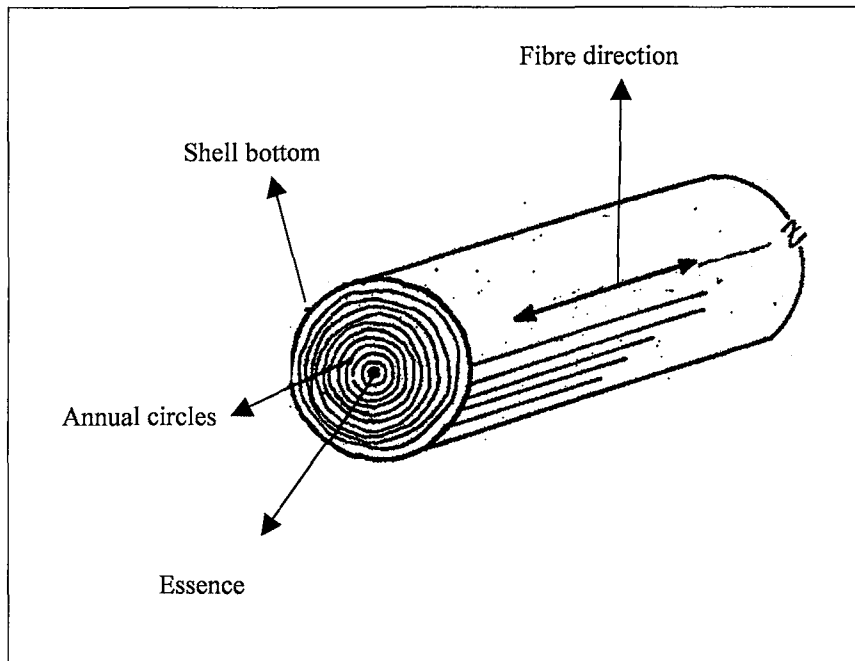

Figure 2.3 Microstructure Of Timber
(Modified from Çobancaoğlu, 1998:22)

2.3 Chemical Characteristic Of Timber

The Chemical Component Of Timber: Eriç (1978: 93) states that in timber, generally, the structure of cells is composed of cellulose ($C_6H_{10}O_5$), and the structure of fibres is composed of lignin ($C_{10}H_{13}O_3$). The results of the chemical analysis of timber structures show that %45-60 cellulose, %20-25 hemicelluloses and %1-2 protein and resin constitute the timber's structure. When timber grows old the amount of lignin increases in its structure. Trees, which have high ratio of lignin, are stiff and have higher resistance.

The Natural Resistance Of Timber: Günay (1994:10) comments that timber has a natural resistance. Wood tissue is the most resistant one among

the plant tissues. When kept in dry places timber resists for many years. High temperature and moisture bring about a decrease in the natural resistance. Resistant timber does not include carbohydrate. In addition, resistance changes according to species of tree. Some examples of hard wood, medium soft wood and soft wood are as in the following (Güngör, 1969: 13).

Hard wood: Oak, beech, ash tree, cedar, chestnut tree, walnut tree, acacia, mulberry tree, elm.

Medium soft wood: black pine, alder, and pine.

Soft wood: fir tree, willow, poplar, and lime tree

2.4 Structural Characteristic of Timber

Timber houses require less heavy load machinery for its construction since it is light in weight. In addition to this characteristic, it is a soft material and the lightness and the softness provide simple implementation with fewer workers for construction. Contrary to common belief, the fire resistance of many wood structures is often considered an advantage of this material. For large timber sections, the burning mechanism consists of charring around the cross-section, which insulates the member and slows the rate of material deterioration due to burning. This mechanism helps the members keep their structural integrity and capacity, unlike other materials such as steel, for example, which experiences a loss of stiffness at temperatures as low as 300°C.

Wood is an orthotropic material. In other words, the material properties can be defined in the three mutually perpendicular directions: longitudinal,

transverse and radial. The strength and stiffness of wood vary according to the orientation of the applied load to the wood fibers.

The loading duration affects the ultimate strength of wood. Long duration load reduces the ultimate strength of wood. Furthermore, the properties and strength of wood members can be affected by the moisture content. For instance, increased moisture content in wood decreases the modulus of elasticity, modulus of rupture and compression strength parallel to grain. Only endurance of wood is augmented by an increase in moisture because it involves ductility and strength. Also, dry wood is less ductile than green wood.

Eventually, material properties of wood show variation, which is an important principle characteristic of timber as a material. The material properties are affected by factors such as the rate of growth, growing conditions and species in addition to knots and other defects. Therefore, the proper grading of wood is very important for the selection of the material for its final use.

2.5 Advantages of Timber as a Building Material

In recent times timber framed buildings have started to disappear one by one, today they are replaced by their imitations such as covered with timber only on facade. Some causes of this change are social bias against timber, economical insufficiency and decrease of the number of timber workman. However, it must be noticed that the advantages of timber are more dominant in the aspect of its specifications (Kılar, 2001). These advantages can be written as below:

- Timber is an organic material and a renewable natural resource.
- Timber does not change in extra heat. For example it does not expand with high temperature and freeze with low temperature.
- Timber is also lightweight material with a good strength to weight ratio. This facilitates designing, transporting, fitting and handling cost.
- It can absorb shock and vibration effect.
- In addition to its mentioned properties, it can be cut and modelled by simple hand tools.
- There are several ways of connection details such as with glue, nail...etc.
- If it is exposed to tension successively, it does not crystallize and brittle.
- Timber is environment-friendly material since its utilisation does not affect the nature negatively.
- Timber is the material for windows and doors and it is heat resistant and windproof. It is a bad thermal conductor and windows do not get frosty even in sub-zero weather conditions. Wooden doors and windows are comfortable both in summer and wintertime.
- It is not damaged by diluted acid and base and does not rust.
- It is also a reusable material.
- It has quick erection times and reduced site labour.
- The small tubular cells that are the fundamental structural elements of solid wood give timber good insulation properties for sound, electricity and heat.

2.4 Disadvantages of Timber as a Building Material

There are some negative beliefs for the timber because of results of the past experience about this material. However, today developing technology has many alternative solutions for the disadvantages of timber. Kılar (2001) notes these disadvantages as in the following:

- Timber is a combustible material. Fire resistance is achieved by
 - Protective enclosure in non-combustible materials,
 - The thickness of the timber section, which provides a degree of protection,
 - The charred surface of the structural timber element.
- If timber absorbs water it swells and when it dries it shrinks. So, there is not only change in dimensions but also rotation in cross-section.
- It is susceptible to decay when exposed to excessive moisture.
- The mechanic properties of timber are not the same in every direction. Therefore the direction of fibre is very important factor for the resistance.
- Unless the necessary maintenance is done, timber can be exposed to decay and bug-infested.
- There are few experienced builders and crews.

CHAPTER III

TRADITIONAL TIMBER BUILDINGS IN TURKEY

3.1 Brief History of Timber Structures

Traditional Turkish house can be defined as those in which Turks have lived throughout their history. Their settlements have been greatly diversified, since they first appeared on the stage of history. Turkish house can be included that were inherited from the Ottoman Empire, some remaining examples of which can be traced back to the 17th century.

Because of its economy and ease of construction, infill-frame construction became widespread throughout Europe from an early period. Timber with brick-infill construction is documented to have first appeared in Turkey as early as the eight century (Gülhan and Güney, 2000). The building tradition travelled from Europe into Asia as a result of influence of Ottoman Empire. Today there are variations on this type of construction in Europe, including England, Spain as well as Asia.

Historical, geographical, climatic properties, construction material, technique and Islamic family understanding are the causes of these houses having many common properties with each other. Traditional wooden houses in Turkey are affected by the regional characteristics of Northern Anatolia, Middle Anatolia, West Anatolia, Southern Anatolia and Marmara Region, which have some similar characteristics, except for the Middle

Anatolia. Coasts and increasing height towards the interior parts characterize the topography. In these regions similar climatic characteristics and flora are also seen. Temperate and rainy climatic in this zone provide wood more available than other materials. Being a strong material resistant to earthquakes is another reason of using timber widely in these regions in the construction of houses. The cost and availability of material are also important factors to prefer it.

Designing the room as the principal unit is the basic property of the houses that have generally symmetrical plan scheme. Furthermore, planning of the houses are also affected some factors, which are the place of family in the society, the effect of its general features in daily life and Islamic beliefs etc. Under the affect of these factors in houses, upper stairs are composed of a common living place, which other rooms have access into and being contrary to the ground floor; the upper floor has projections and many windows. In addition, downstairs which have service spaces, which have no access to outside and have a garden or a courtyard in the inner part.

According to the availability and existence of timber, construction methods used in traditional Turkish wooden houses change from region to region such as *hımış* and *bağdadi*, which are shown in Figure 3.1 (Yarar, 1978). Moreover, there are various types of wall infill systems like Triangular (Tr:muskalı dolma), Cubby-hole(Tr: Göz Dolması) that can be seen in Figure 3.2 and Figure 3.3 (Köystüren, 2002: 16).

Although, in every settlements all around Anatolia, most of traditional structures are in a bad conditions, there are some settlements like Göynük, Safranbolu, Bartın, Kula, Amasya, Efes, Selcuk, Kula, Odemis etc., which have not been affected by the technological changes and have kept the

impressive examples of traditional Turkish wooden houses as stated in Figure 3.4.

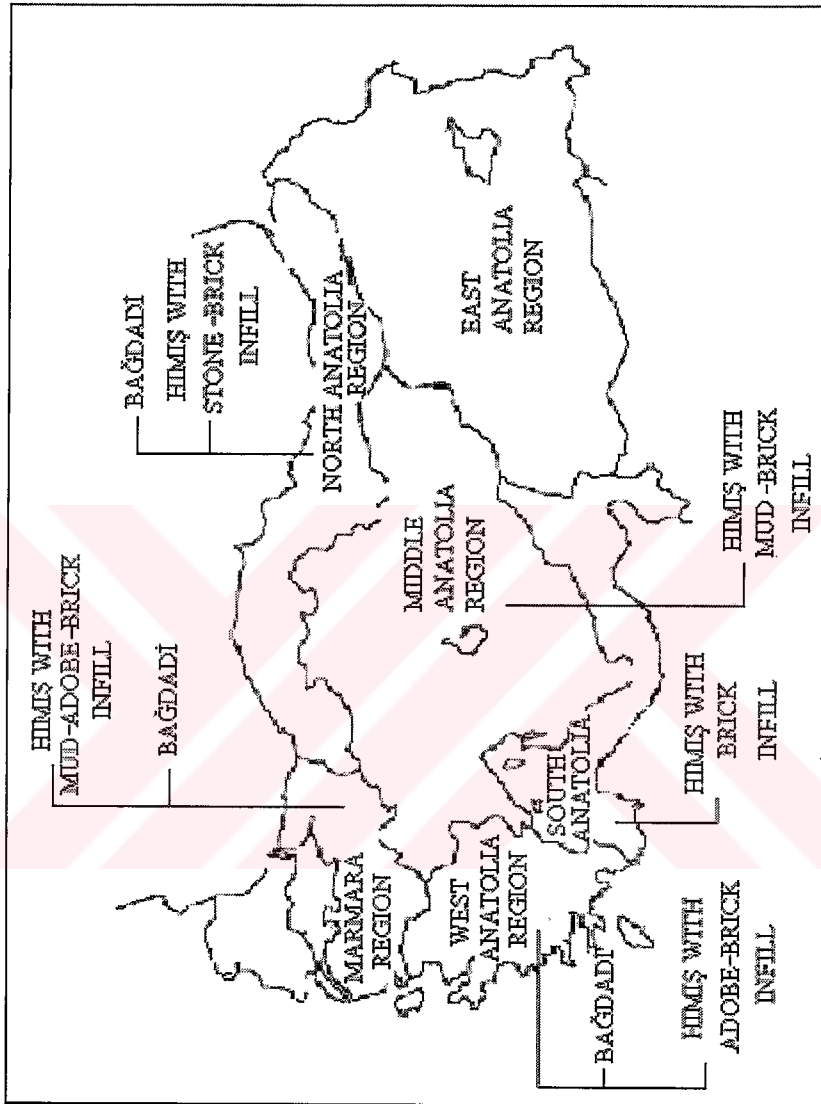
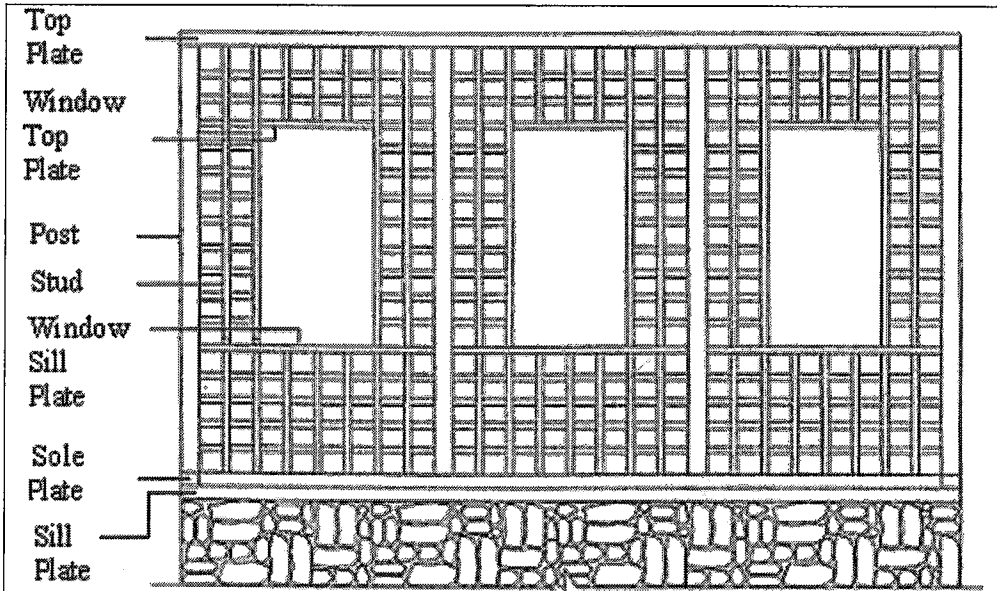
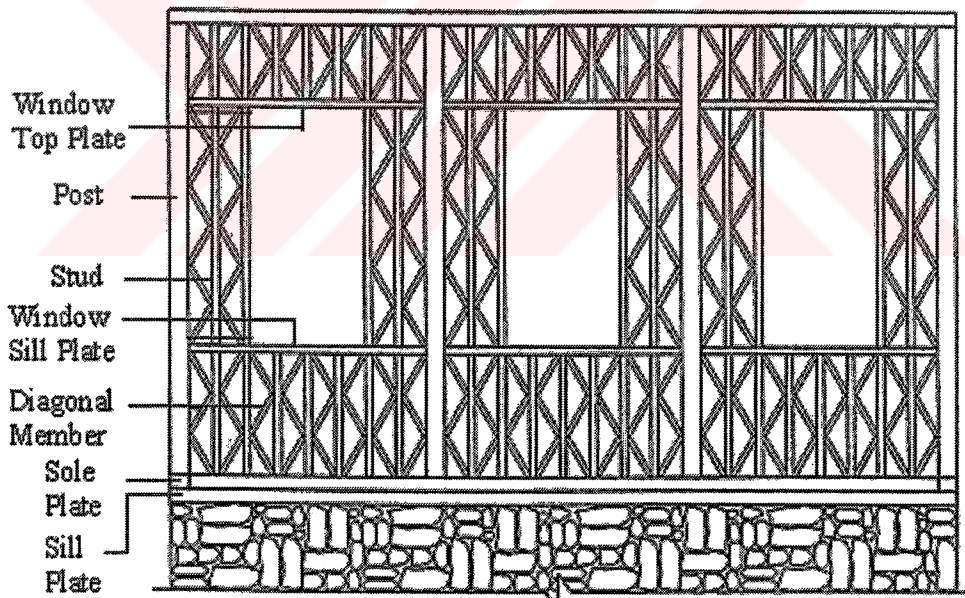

Figure 3.1 Turkish Wooden Houses According To Region (Yarar, 1978)



Cubby-hole Filling (Tr: Göz Dolması)



Triangular (Tr:muskalı dolma)

Figure 3.2 Types of Wall Infill Systems (Köysüren, 2002:16)

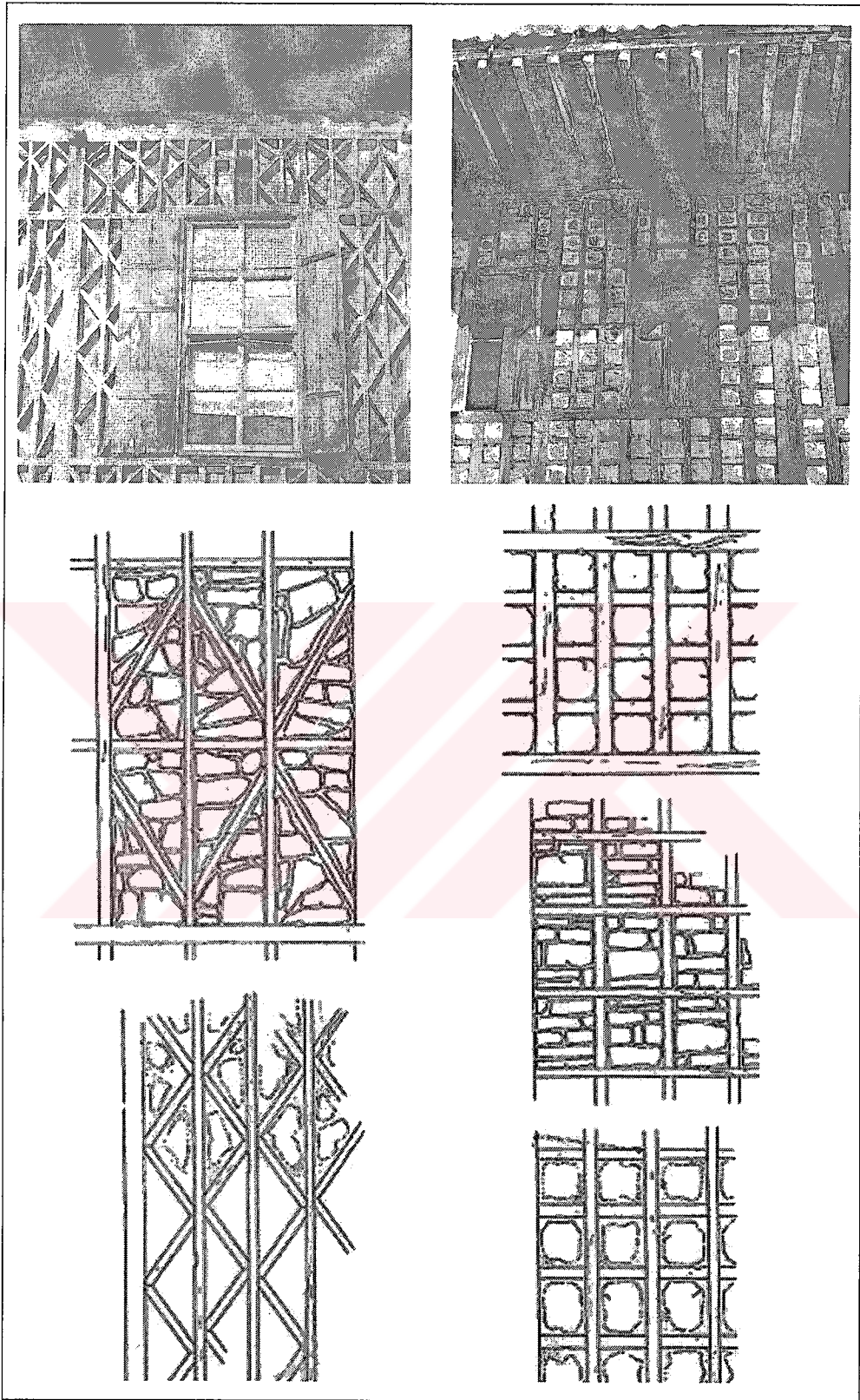

Figure 3.3 Types of Wall Infill Systems (Özgüner, 1970:25)



Göynük



Safranbolu

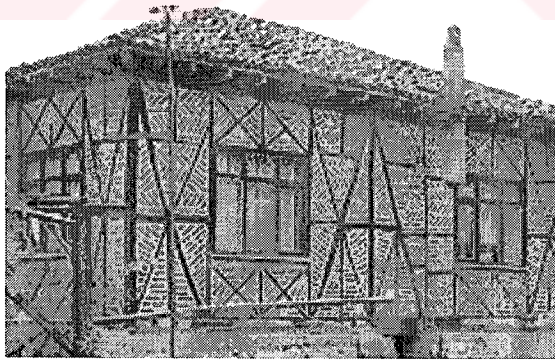

Düzce

Figure 3.4 Examples of Traditional Turkish Wooden Houses

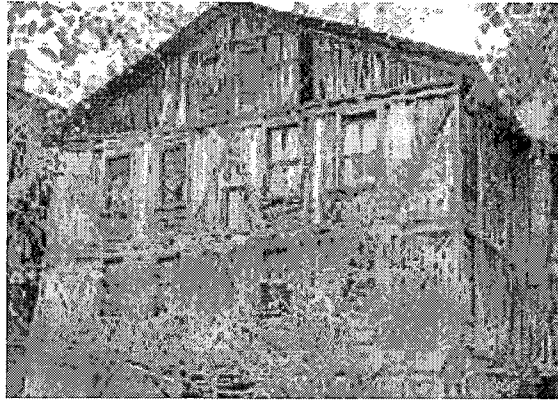

Mudurnu



Rize



Bolu -Hacı Musalar

Figure 3.4 (Continued) Examples of Traditional Turkish Wooden Houses

3.2 Traditional Timber Material

Wooden houses can be found mostly in rich forest areas, which are seen generally in the northern, western and coastal parts of Anatolia. Günay (1998:30) points out that timber which is the main material of Turkish Houses, defines also the geographical border of Turkish Houses. Truly these types of structures take part in where the wood is abundant.

According to records at present Turkey have 45.000 registered monuments and dwellings most of which are wooden houses and are situated on 4.000 various sites of Anatolia. The oldest housing units were built during 17th century, whereas the majority of them dated back at the end of 19th century.

Especially in Black Sea Region whole life was related with wood; such as buildings and ships for fishermen, coaches' tools and traps, furniture and even children toys. Economic and limited transport conditions led to use local materials. As a result timber was not only used as a building material, but also used for decorative purposes because of its properties as stated below:

- Timber is resistant to climatic conditions and earthquake.
- It has high load bearing capacities.
- It is the only building material that has a renewable source.
- It is an easily workable material.

Traditional timber buildings have various types of timber elements such as main posts, window-door posts, footplate, wall plate, primary bracing elements and secondary bracing elements. Depending on their functions, the

length of timber members' change. Also these elements have different cross-sections as in the following:

- The unit of main structural elements changes from 12x10 to 9x9.
- Maximum length of the timber elements is 4.00 or 4.5 m.
- For secondary bracing element the cross-section is about 5x10 cm.

It is observed that the cross-section and length of all these members vary in a very large interval. Eventually by using obtained experiences about traditional timber framed structures some rules were developed to get structures with adequate strength.

3.3 Construction Systems of Traditional Turkish Wooden Houses

There are very distinctive styles of traditional architecture in Turkey, resulting from cultural attributes related to material availability and climate. Detailing of traditional construction by using wood is nearly forgotten and lost. Many villages in the timber region or in the southeastern part of Anatolia are reverting to brick and concrete structures, instead of keeping the traditional system. As known, wood has a strong resistance against earthquakes; therefore it is not surprising to see usage of this material for buildings in highly seismic areas.

Anatolia always has been one of the most important bridges between Europe and Asia in many aspects. Therefore development of a classical Turkish house has been influenced by many civilizations and can be considered as a synthesis of all these background.

3.3.1 Foundations

The superstructure of a building is built on the foundation that transfers the load of the building to the ground. Thus, foundations should have adequate strength and stability.

Stone is commonly used for the foundation of the traditional timber constructions. The depth of the foundations changes according to the characteristics of the land where the structure is erected on. If the ground is not homogenous, foundation is expected to go deeper. The thickness of the masonry walls vary between 50 and 90cm. Therefore for construction it is necessary to find specific solutions for each structure because of different conditions.

The foundations of traditional timber construction consist of single foundation (discontinuous), continuous foundation and composite foundations that are used according to their structural characteristics, local conditions and types of soil.

Single Foundation (Discontinuous): Köysüren (2002:37) states that this system is generally used in constructions where the ground floor is left partly empty. In this type great sized stones are used under the posts, which are raised 25-30cm above the ground level. If small sized stones are used, it will lead failure. While the posts are putting on stone bases, no connection details are used. Due to the fact that these posts are not connected together in ground level, the foundations do not behave continuously.

This foundation type is used to keep the timber posts clear from the damp ground. It can be seen in Figure 3.5.

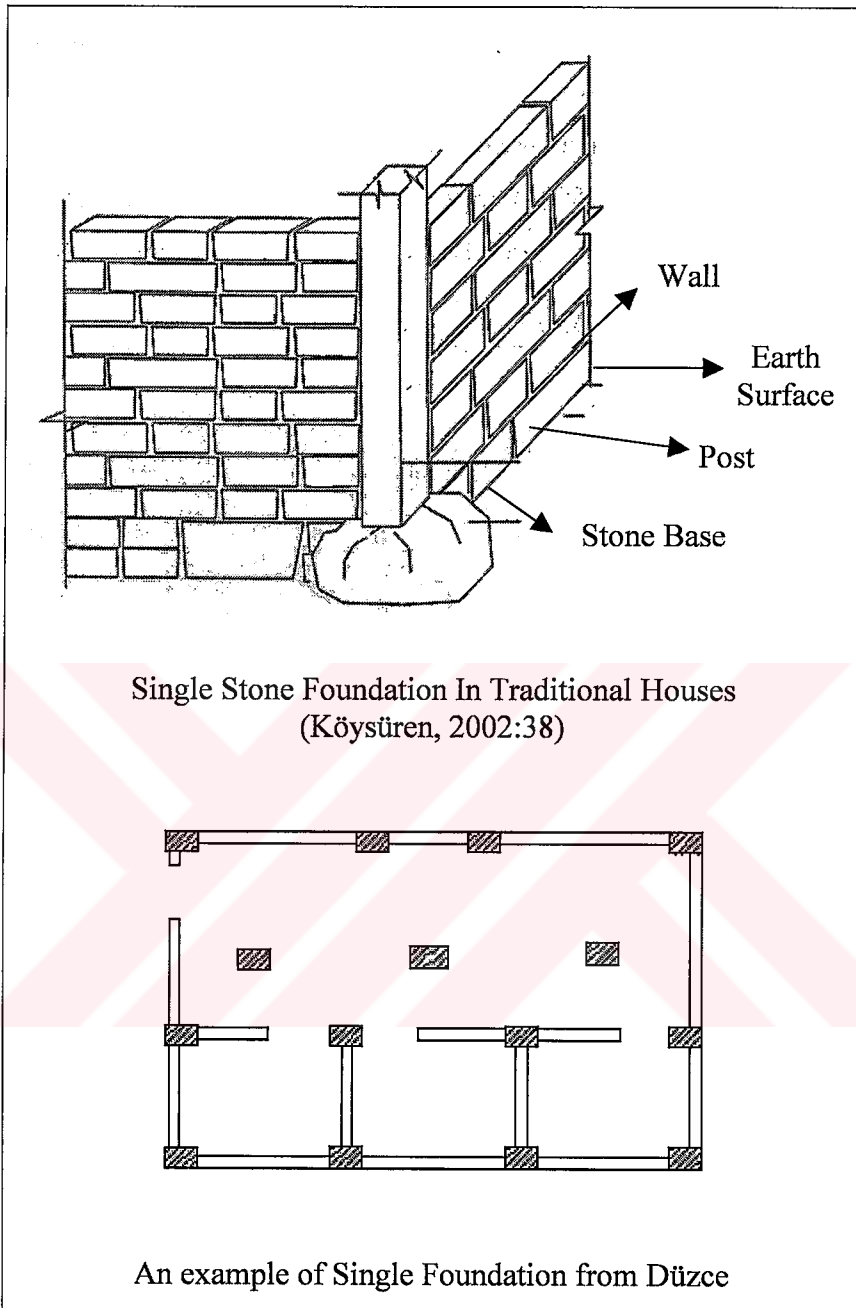

Figure 3.5 Examples of Single Foundation

Continuous Foundations: This system was commonly used in structures built at the end of the 19c. because of the simple cubic mass of the buildings as mentioned by Şahin (1995) . In Figure 3.6 an example of composite

foundation is indicated. Continuous foundation, which forms a frame under the external edges and through the axis of the building made of rubble stone masonry (Figure 3.6). According to the Turkish Building Regulation (1998), masonry foundation should be built with reinforced concrete footing and lintel as in Figure 3.7.

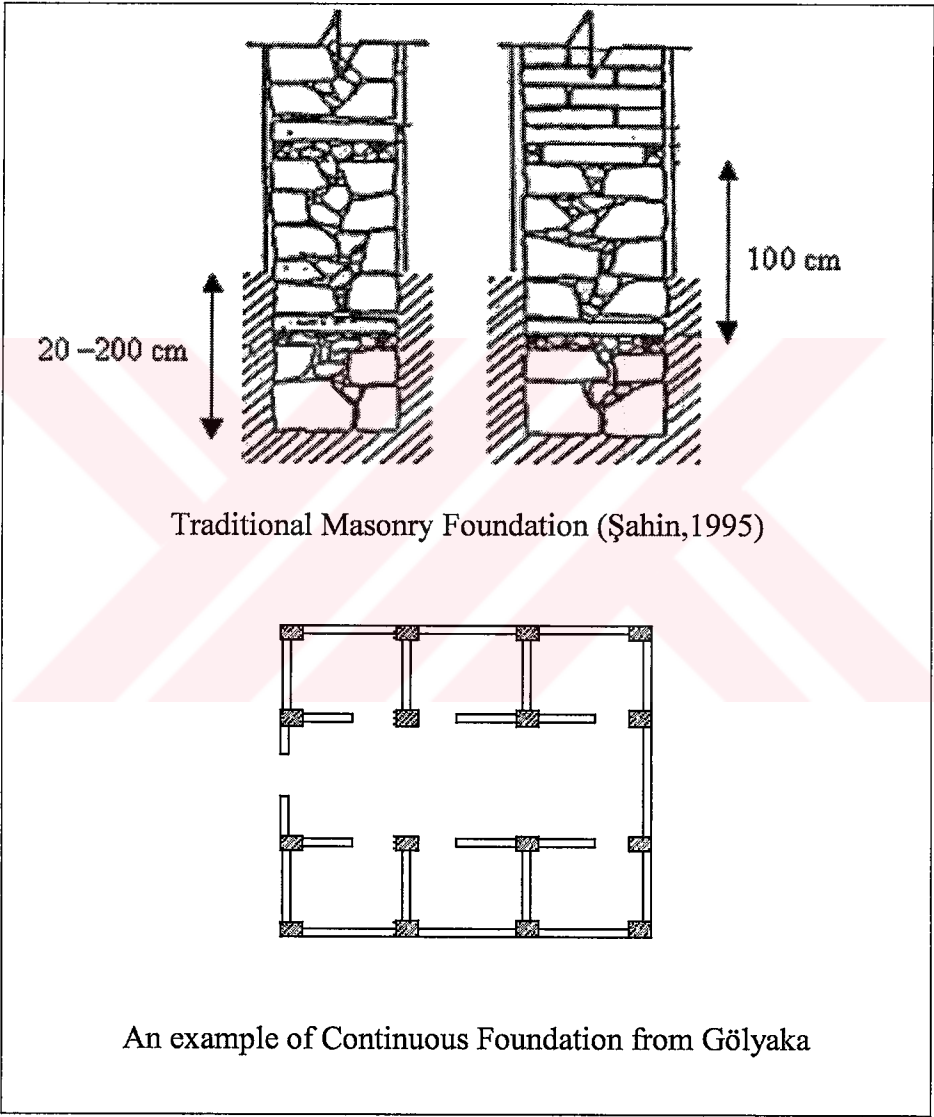

Figure 3.6 Examples of Continuous Foundation

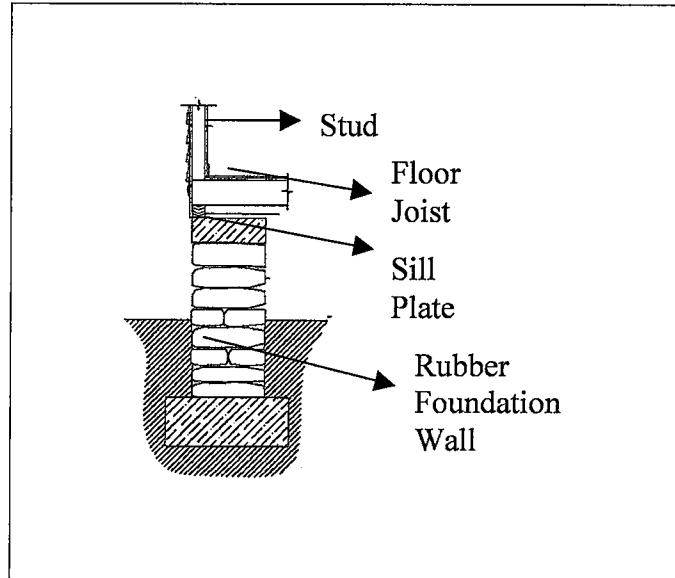

Figure 3.7 Masonry Foundation with Reinforced Concrete Footing and Lintel According to Turkish Building Regulation

Composite Foundations: The foundation of the external edges of the building is rubble stone masonry forming an outer frame, and the inner axis or partition walls made of timber framed system are supported by separate main posts in the foundation. The rubble stone foundation walls reinforced by the timber beams are placed on the interior and exterior faces of the wall around one meters apart from each other, which is a tradition dated back to prehistoric periods in Anatolia. As indicated by Şahin (1995) the main function of the timber beams was to form a frame around the masonry and to provide the unity of the wall (Şahin, 1995). In Figure 3.8 an example of composite foundation is indicated.

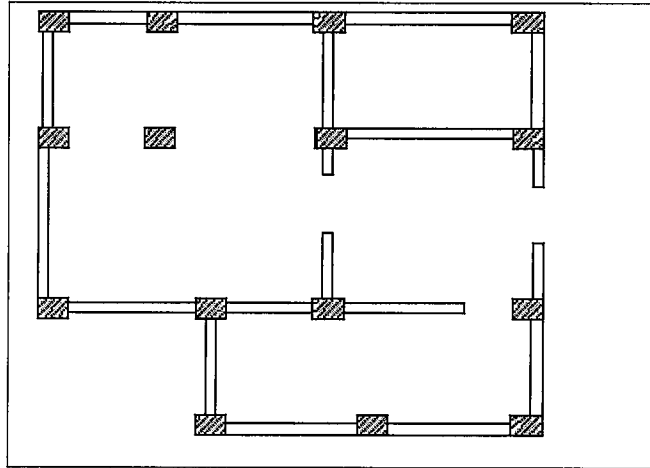

Figure 3.8 An Example of Composite Foundation from Mudurnu

According to Gakkai (1970) foundations of wooden structures shall be constructed on solid ground after removing surface soil. The base of foundation should be more than 45 cm below the ground surface. In the districts with expected freezing, the base of foundations shall be set below to freezing line. In case of thick surface soil and soft ground, broken stone foundation or other foundations should be made. When the soil is especially soft and the loads transmitted to the foundation is great, piling foundation shall be adopted.

3.3.2 Floors

The construction of floor can be made in several ways according to location of the floor and the type of the wall system. The members of floor framing are as in the following:

- Girders, which are the main structural elements of floor, used in large spans because they can resist large forces and transfer them to posts and foundation.
- Beams are the secondary structural elements but they provide support for floor joists as a girder.
- Joists, which are the last category of members, harden by bridging, beams, girders and header joists.

It is observed that these members of floor framing were not used in all type of floor construction. Three different ways of ground floor construction were defined by Şahin(1995: 191).

First solution: Timber beam is placed on a stone platform inside the foundation walls and joists are set on this beam (Figure 3.9). Between the stone platform and the pressed earth there is min. 20-30 cm air space for ventilation.

Second solution: The floor girders are placed on the timber beams, which are inserted into the walls (Figure 3.9). The same way is used for building timber floor. But it is difficult to replace the deteriorated timber floor members.

Third solution: Floor girders are set on the beams, which are install on the posts located at the edges of the space (Figure 3.9). The disadvantage of this system is ground water problem.

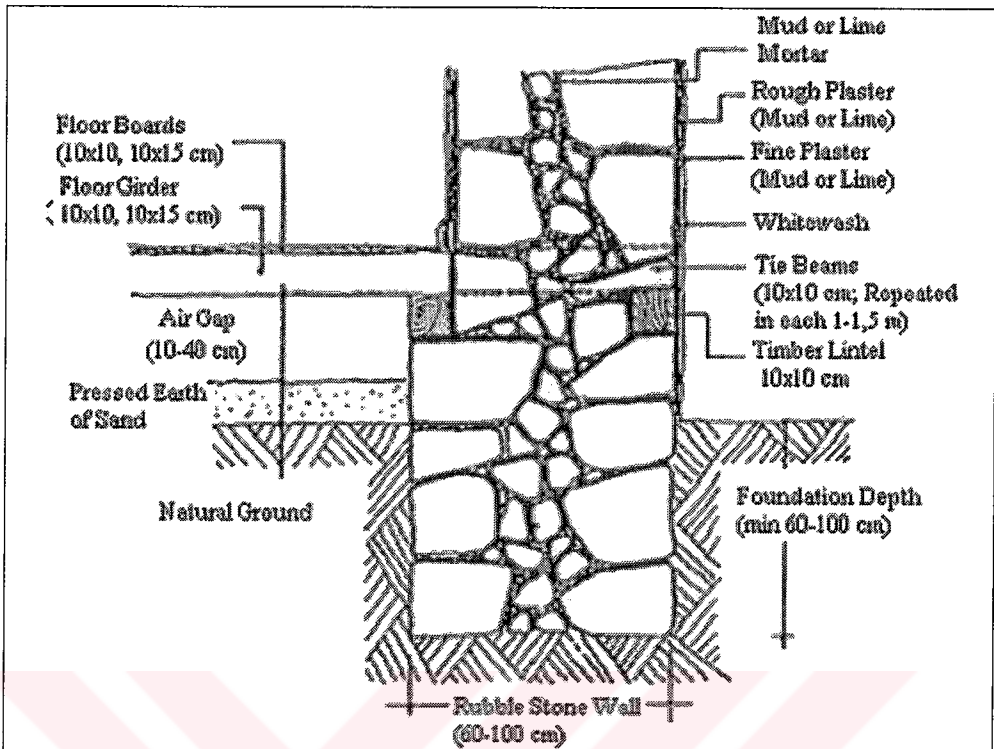

Heightened Floor, Supported by Stone Plint (Modified from Şahin, 1995)

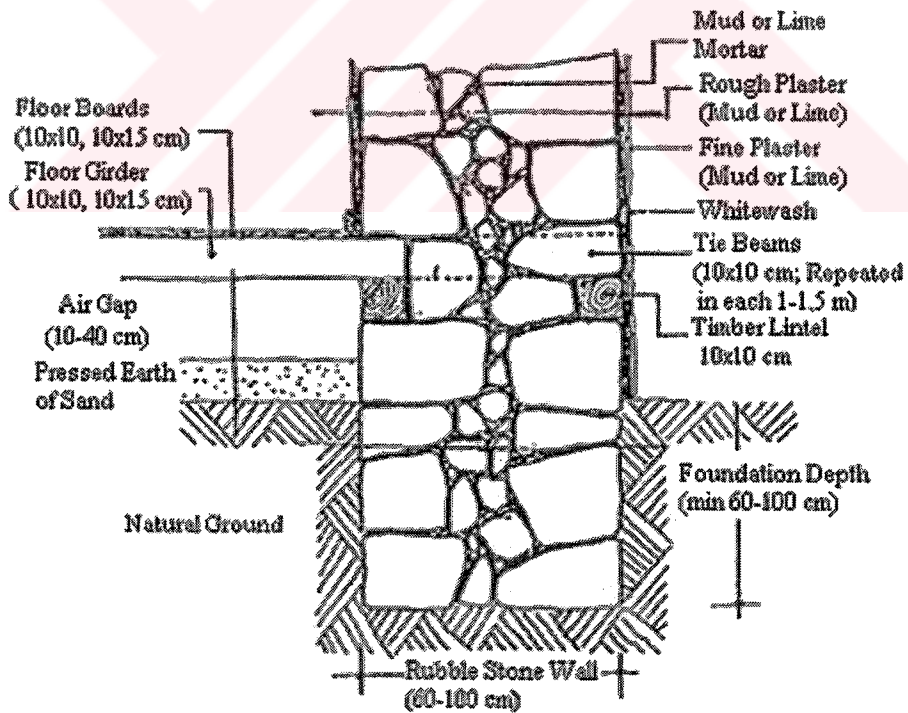

Heightened Floor, Inserted Into The Wall (Modified from Şahin, 1995)

Figure 3.9 Floor Construction Types (Modified from Şahin, 1995:191)

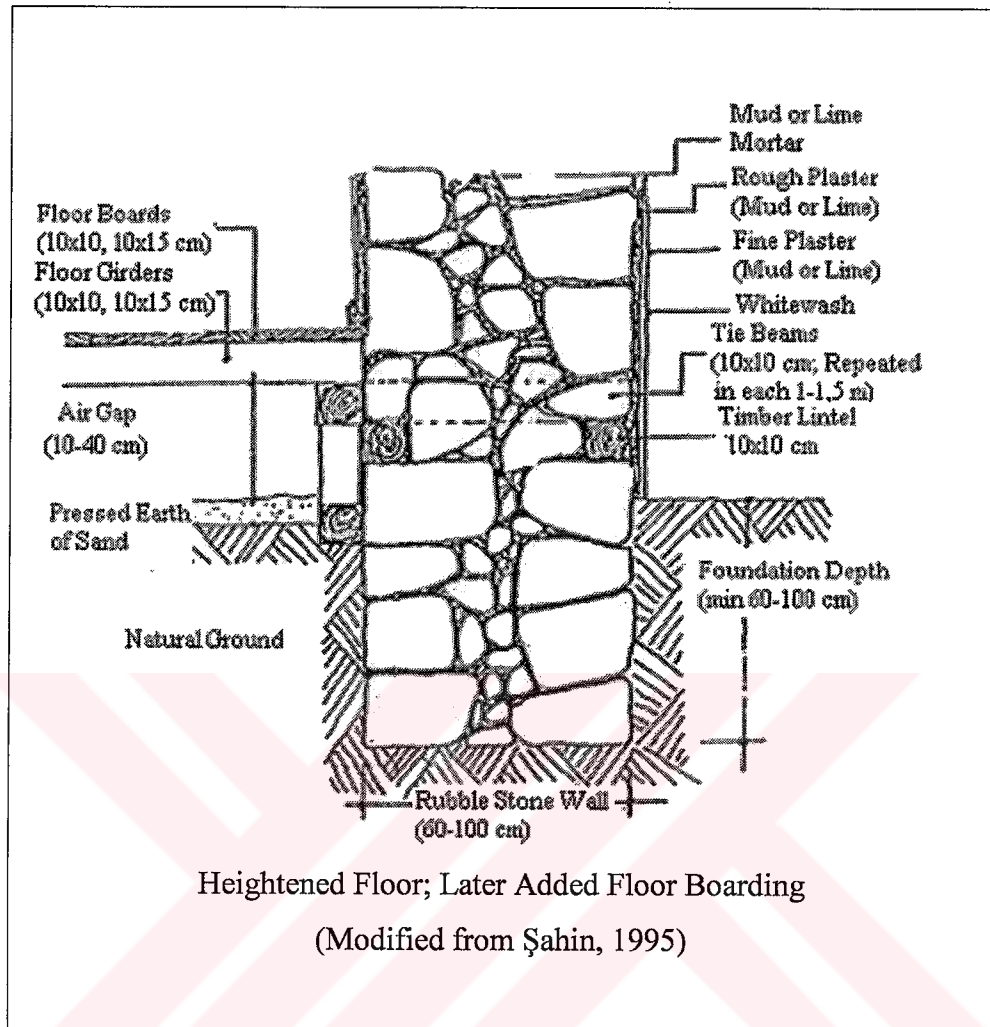
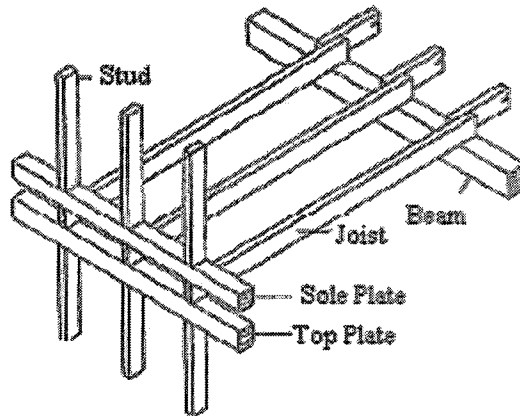

Figure 3.9 Floor Construction Types (Continued -Şahin, 1995:191)

Köysüren (2002:66) defined two different upper floor construction types. These are as in the followings:

First solution: Köysüren (2002) defines this solution that beams aligned to the posts are strengthened with joists. There is 200 cm space between beams and 30-70 cm space between joists (Figure 3.10).

Second solution: Simply a structure of joists (Figure 3.10).



First Solution: Floor Framing Built of Joists Supported by Beams

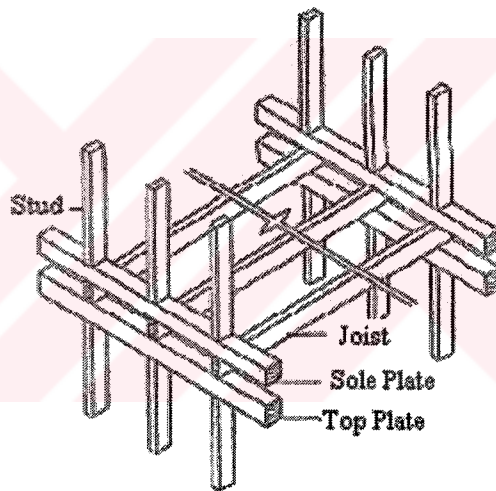

Second Solution: Floor Framing Built of Joists

Figure 3.10 Upper Floor Construction Types (Köysüren, 2002:66)

In traditional floor construction floor girders are placed commonly parallel to the short side. There is another method, double plates with single direction (Tr: tek yonde çift tabanlı) is called by Eldem(1966:G3). In this

system floor girders on which sole plate is installed, are placed on wall plates that are on the inner and outer faces of masonry walls (Figure 3.11).

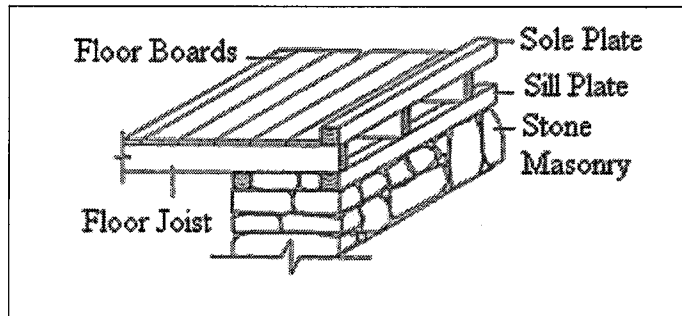

Figure 3.11 Floor Construction in Timber Framed Section
(Köysüren, 2002:67)

Another alternative of double plates with single direction was defined by Sahin(1995:195). In this system similarly as in the former system, floor girders are placed on top of wall plates (Figure 3.12). There are second floor girders which are perpendicular to the one below were set. This system provides isolation by filling between the joists with earth or sand. In the service space floor tiles for pavement and courses filled with a waterproof hydraulic mortar (horosan) are used.

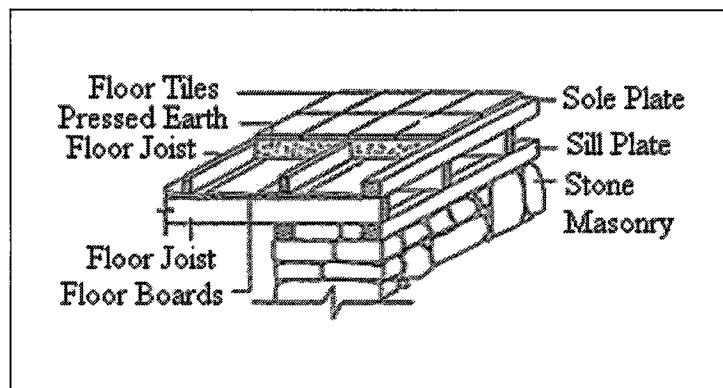

Figure 3.12 Double Layered Floor Type (Köysüren, 2002:67)

3.3.3 Timber Framed System

Timber framed systems of Turkey are the products of the thousand years. Furthermore this system was widely used in countries of Balkan, which were under the Ottoman Sovereignty for a long time and effected from same culture.

Framed system of traditional timber structures consists of vertical, horizontal and diagonal members which are main posts, studs, window and door sills, wall and foot plate, tie beam and braces (Figure 3.13). Their functions can be seen in Table 3.1. Systems of traditional timber structures can be examined in two groups that are himiş and bağdadi as stated in the article of Anadol and Arnoğlu(1973). Gakkai (1970) states that wooden structures frameworks constitute wall frames to support the loads of roofs and floors; at the same time they are the principal structural parts that resist the earthquake force and other horizontal forces. This part of the structure affects directly the resistance of the building against earthquakes. According to Gakkai (1970) pertinent framework construction must have the following conditions:

- Each member shall be arranged approximately so that there is no big opening and diagonal timbers having required sectional size are disposed appropriately.
- Sectional size of members shall be the required size, and there is no big notch by connection and others.
- If the positions of connections and joints are appropriate, they will bear stresses expected at those positions.
- Constructed frameworks do not cause large displacements and deformations under design external forces.

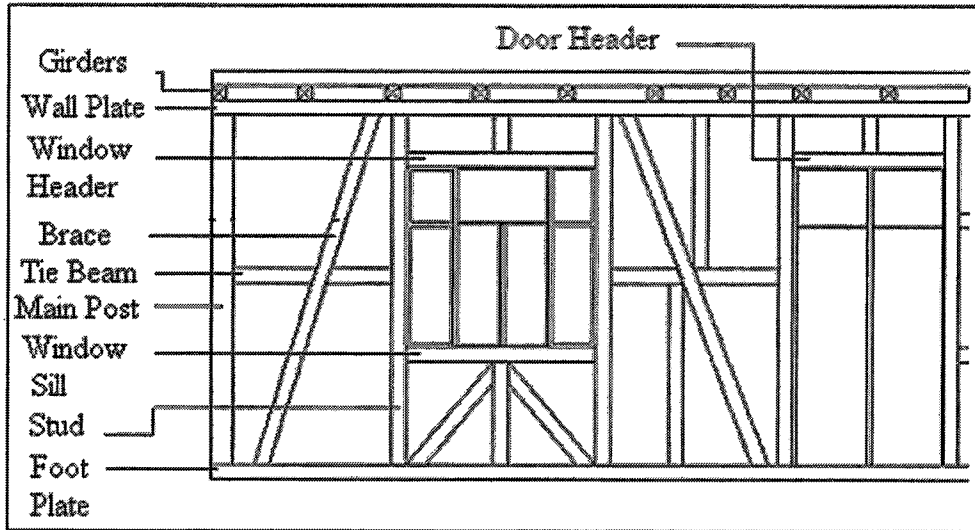

Figure 3.13 Members Of Timber Framed System

Table 3.1 Functions of Timber Frame Members

Members	Functions
Main Posts	They are placed at the corners of the spaces in traditional timber framed. Main posts that have commonly 10x10 cm or 15x20 cross-section and set on the floor plate define the basic axis of the building. They do not have a specific length, which can be changed according to the floor height.
Studs	Studs are secondary structural posts, which are used for framing the openings and dividing the distance between the main posts. The cross-section of them is usually 5x10 cm. With the support of studs, posts are placed at intervals of 120-150. In addition they carry the load and infill material. The distance between the studs varies from 20 to 90 cm.

Table 3.1 Functions of Timber Frame Members (continued)

Window and Door Sills	These are upper windowsill, lower windowsill and upper doorsill. Sill is a horizontally laid timber member with 5x10 or 5x15cm.
Foot Plate	Main posts are placed on footplates that have different cross-sections such as 10x10, 10x15, and 15x15 cm and also they are connected with the main girders on the walls.
Wall Plate	Wall Plates not only carry the floor girders, but also combine the main posts. Like footplates, their cross-sections vary between 10x10, 10x15 and 15x15cm. In addition wall plates are placed in the wall.
Tie Beam	Spaces between the studs and posts are divided by tie beams, which are used also for increasing the strength of the construction. In addition to these they hold the infill material. The thickness of ledger changes between 2.5 cm to 7 cm.
Braces	They used for providing the resistance of structure against horizontal forces. Braces consist of primary and secondary braces. The primary braces are placed between the top and foot. But the height of the secondary braces are smaller than former. Because they do not continue from foot to top. In traditional structure different kinds of braces were used which are shown in Figure 17. Braces usually have 10x10 or 5x10 cross-section and they are put with an angle of 45 ⁰ or 60 ⁰ .

Diagonal bracings are the most important members because they stiffen the frame of wooden buildings and increase the resistance against earthquakes. It is desirable for the diagonal bracing to be put with the slope as gentle as possible. One diagonal bracing in a unit rectangular frame, should be firmly tied to near the joints of columns and beams.

When the space between columns is narrow, diagonal bracings are often arranged in K form to avoid the steep slope of diagonal bracings as shown in Figure 3.14 (Bayülke, 1934:96). The structural method of Figure 3.14.A.a is desirable if the diagonal bracing slope is steep and stresses become great.



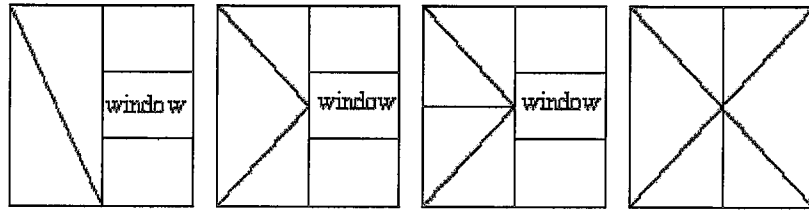

a b c d

A. Different Installation Types Of Braces

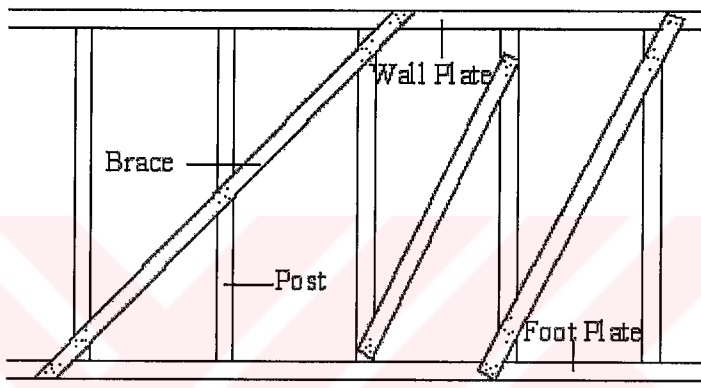

a Good b Bad c Good

B. The Connection Types Between Braces and Plates and Posts

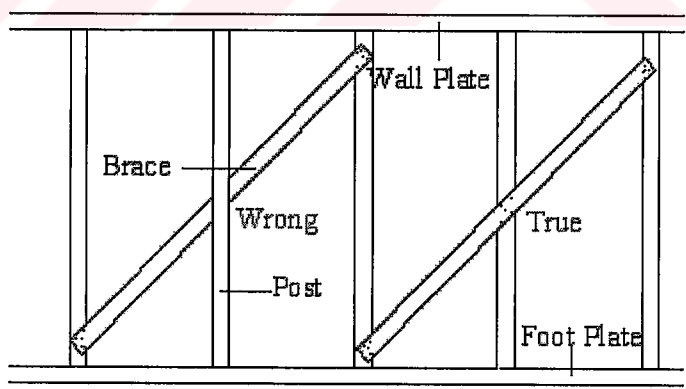

C. Connection Between Long Braces and Posts

Figure 3.14 Connection of Braces (Modified from Bayülke, 1934:96)

3.3.3.1 Hımış

This is a filled-in system, which is made by forming a bearing structure by means of fixing woods on the foundation or on the heap (of rocks, adobes or woods), and by filling adobes, rocks or bricks between these vertical and horizontal bearing elements and the frame that the beams form (Çobancaoğlu, 2001:1).

In traditional timber structures, generally surface of the interior walls are plastered whereas the exterior walls are sometimes unplastered. Roof and bearers are the main parts of the hımış structures. Walls transfer the loads coming from the roof to the foundations. The main posts, studs, braces and beams are the primary structural elements of hımış structures. Furthermore, the diagonal members of this system are of great importance in increasing the lateral strength of timber fill structures. The lack of these elements in the frame parallel to the direction of vibration causes inelastic deformations. Stone is used for the foundations that are usually constant stone bases with the 1.00 to 1.50 meter height. According to the characteristics of the regions some variations are observed between structures in different areas such as infill material, types of wood used in the system, foundation types etc. Some examples of hımış structures from different cities are shown in Figure 3.15 by Çobancaoğlu (2001:809). The walls of hımış systems were usually described in four different groups according to infill material that are as in the following.

- Brick Fill
- Sun-Dried Brick Fill
- Stone Fill
- Tree and Mud Fill

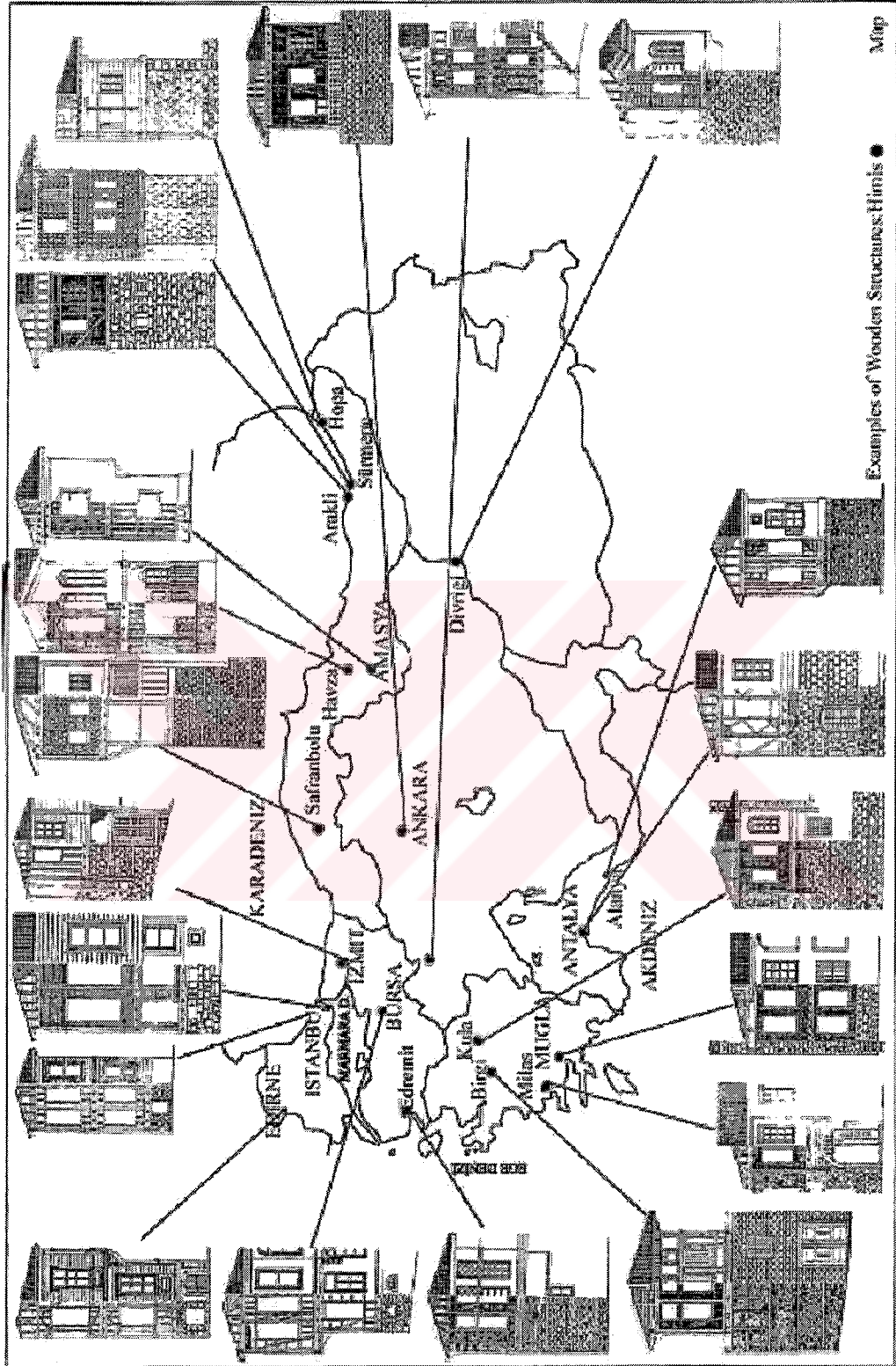

Figure 3.15 Himiş Structures From Different Cities

(Çobancaoğlu, 2001:809)

Brick Fill: This system was first used in 16th century. Due to the lack of wooden workmanship this traditional system started to disappear after 18th century (Çobancaoğlu, 2001). In this method brick is used for infill material and the thickness of the wall approximately the size of a half brick. In addition, spaces between the posts, which are generally 80-90 cm., are divided with diagonal members. Filling the bricks into wall can be shaped into horizontal, vertical and crosswise. Especially exterior walls that are closed to street were filled different shapes and were not plastered. Surfaces of timber framed houses with brick filled were sometimes left unplastered whereas sometimes plastered except beams and posts. An example of himiş structure with brick infill from Düzce is shown in Figure 3.16.



Figure 3.16 An Example of Himiş Structure with Brick Infill from Düzce

Sun-Dried Brick Fill: Another filling material is sun-dried brick in other words adobe that is the most primitive technique used in villages. Being an economical and heat resistant material, requiring less workmanship than the other makes it a widely used material. This system was generally used in Kastamonu, Çankırı, Çorum, Göynük, Taraklı, Sivas, etc. (Figure 3.17).

In frame main posts that placed in every 1-1.5 m, studs with 60-70 cm spaces between main posts and diagonal members carry the fill. Sun-dried brick sizes vary according to region but the most widely used dimensions are 40/40/12 cm. Surfaces of the houses built with this system were plastered with mud except the main posts and beams.



Figure 3.17 Traditional Timber Buildings with Sun-Dried Brick Fill
(<http://www.sivas.gov.tr/tarihivasevleri/k14.htm>)

Stone Fill: Timber framed houses with stone filled are commonly used in areas characterized by coasts and forests. In this system, spaces between

members of wooden frame are filled with stones of which dimensions vary between 10-15 cm and plastered from both sides. The thickness of the wall is approximately 20 cm. Some examples of them are shown in Figure 3.18.

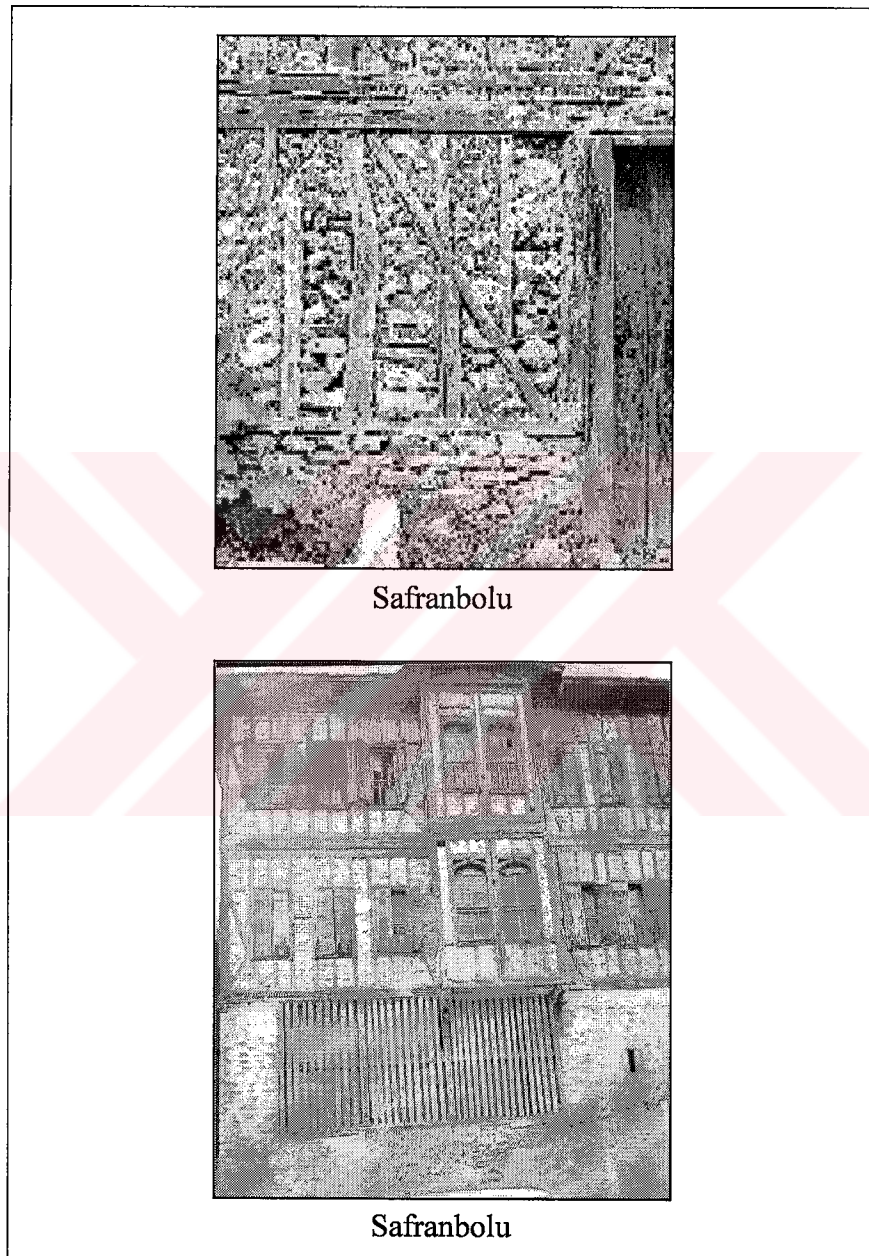

Figure 3.18 Traditional Timber Buildings with Stone Fill

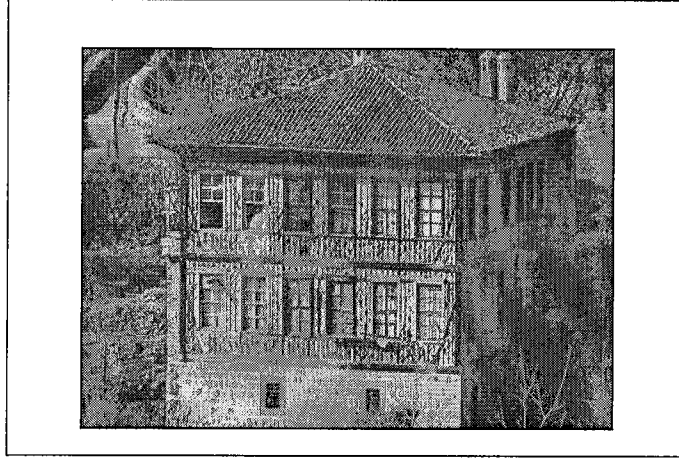
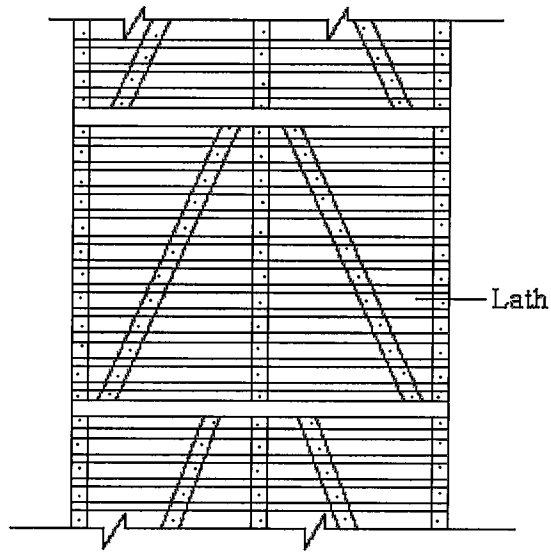

Figure 3.18 (continued) Traditional Timber Building with Stone Fill in Rize

Tree and mud fill: This system was generally used in Muğla and Milas. Spaces between the members of frame were filled with trunk shells and plastered from both sides.

3.3.3.2 Bağdadi

Urban type timber structure named, as “bağdadi” is a kind of wall cladding that can be seen in all regions of Anatolia. In this system wooden lathes with 2.5-3.5 cm width on both inner and outer wall surfaces are nailed in horizontal direction (Figure 3.19). In some regions, instead of lathes reeds were used. The space between the surfaces is filled with loose, light insulating material or is left empty. The surfaces are covered with plaster that is usually composed of mud and straw. The ductility and damping capacity is increased by the use of nails and lathes prevent infill downfall. As a result, this type of structure is a more refined form than “hımış”. On the other hand, their constructions require vast amount of wooden lathes and a large contribution of workmanship.



Bagdadi Construction System (Modified From Bayülke, 1934)

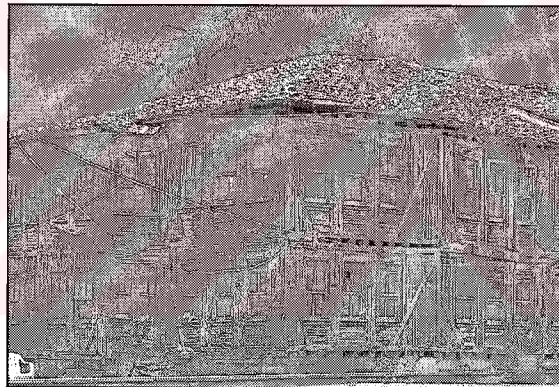

Figure 3.19 Examples of Bağdadi Structures from Mudurnu

3.3.4 Wood Block System

Kafesçioğlu (1954) points out that the timber building examples, which have stood up to date, indicate that the most of the timber structures have been built with wooden block system. These kinds of structures are seen mostly in mountain villages of Black Sea Region. Since the owner of the every houses and workers could provide wood easily, they have preferred timber for housing construction. In addition, this type of structure does not require workmanship and does not need so much material in construction process.

According to Kafesçioğlu (1954), wood block system used in Turkish Houses consists of two types as following:

- Simple Wood Block System with Round Logs
- Wood Block System with Rafters

3.3.4.1 Simple Wood Block System with Round Logs

This system is a typical constructive technique of the mountain villages of Black Sea Region. Mainly in Bolu, Gerede and Göynük, the wooden parts of the rural buildings are realized with this constructive technique.

The walls are made of overlapping round logs that cross in the corner. Two different solutions of corner joints are used. In the first solution, a half-lap joint, the upper half of the log section is removed. In the second solution, the wood is removed from both the upper and lower faces of the log as

shown in Figure 3.20 (Kafesçioğlu, 1954). Çakır (2000) states that these connection details are called as Karaboğaz.

The door opening is created with two jambs that are correlated to the overlapping logs with tongue and groove joints. The top of the jambs is fixed in the log that is lintel. The bottom of the jambs rests on the stone masonry basement.

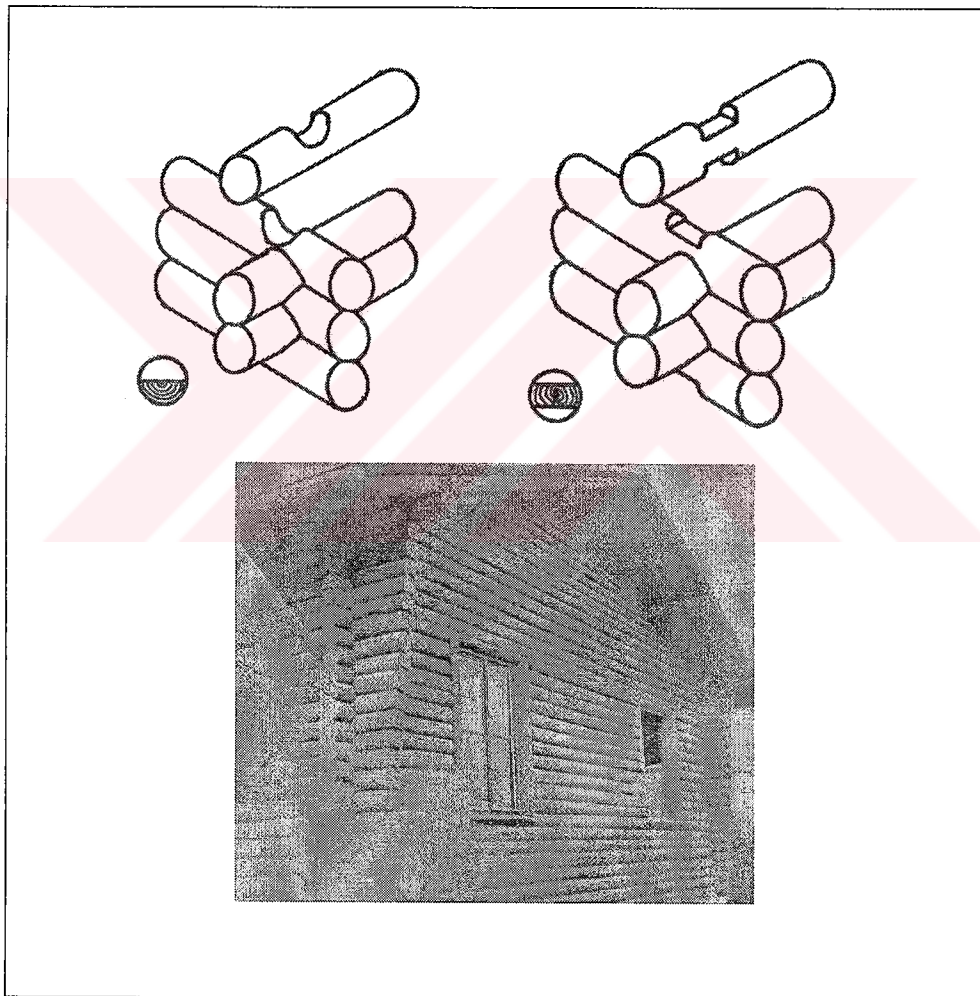

Figure 3.20 Simple Wood Block System (Modified Kafesçioğlu, 1954)

3.3.4.2 Wood Block System with Rafters

This system springs up from simple wood block system with round logs however; it has more sophisticated connection details than the former. It is usually used in the inner parts of the Black Sea Region. The form of logs is generally rectangular. Çakır (2000) points out that this system called as Çantı and it can be examined in two groups such as wooden block system placed on the masonry walls and wooden block system placed on the posts. In horizontal direction logs are inserted on the masonry wall that have 50 cm width in the former type. The load is transferred to the ground logs and masonry walls, respectively (Figure 3.21).



Figure 3.21 Wood Block System with Rafters

In the second type of wood block system with rafter, special connection details are used. A floor, whose thickness is 4-6 cm, is created with laths. Load is transferred to the ground by the posts that are placed on the big stone pieces. The most beautiful examples of these structures named as serender are in East Black Sea Region. An example of this structure is shown in Figure 3.22.

These structures are built in order to store crop and to protect the crop from moisture and insects. They have generally rectangular or square plan shape and their posts and beams do not have connective materials. They are classified according to their modules and the number of posts. Some of them have ten posts.

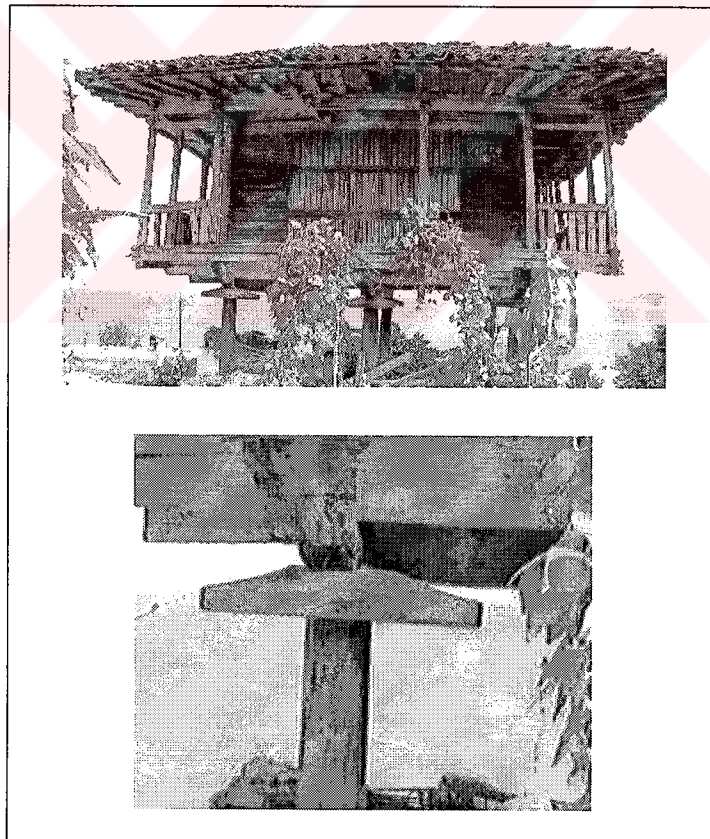

Figure 3.22 A Serender in East Black Sea Region

3.3.5 Roofs

In traditional structures, because of snowy and rainy climates steep roofs were used. To resist specific loads, there are many framing elements such as braces, purlins, beams, posts, rafters etc. in these pitched roofs. These members transfer loads from roof to walls. Functions of them are shown in Table 3.2. In traditional Anatolian roof framing, hip roof was mostly used. In hip roof, load is transferred from purlins to roof than roof beams. The space between the rafters are 40 to 60 cm., Şahin (1995: 201) has indicated the traditional roof structure of Ankara (Figure 3.23).

Table 3.2 Functions Of The Traditional Roof Members

Members	Definitions
Ridge Purlin	Ridge Purlin, which is the peak of the roof, is supported by the king posts and also holds the rafter together.
Rafter	Rafters, which resist all loads, are commonly 5x10cm in cross-sections with spacing of 40 to 60 cm.
Purlins	Purlins, which are placed on between the ridge piece and the external edge of walls by dividing this interval into two or three parts. They are perpendicular to rafters and support for them. If the distance is appropriate for rafter they may not be used.
Posts	There is an order in transferring the loads from roof to walls. So purlins and ridge transfer the load to posts that transfer the load to beams. If posts are placed at the corners, they are called corner king posts. If they are used to support ridge purlin, they are called king posts.

Table 3.2 Functions Of The Traditional Roof Members (continued)

Timber Panel	Timber panel, which is covered on the purlins, has 2 cm thickness.
Tiles	Tiles, which are placed on the top of the roof to complete the structure.



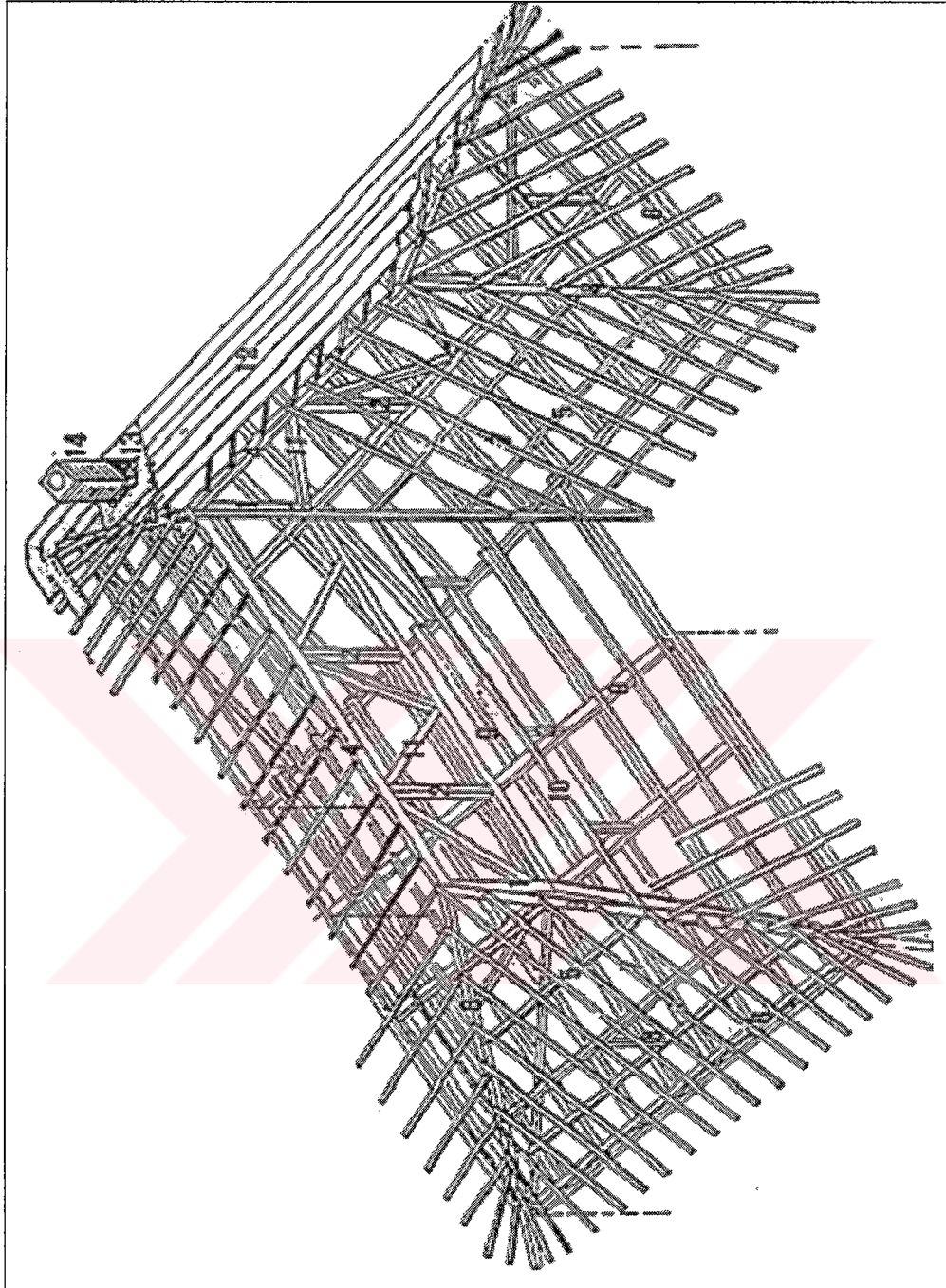

1. Corner Post	3. Post	5. Purlin	7. Rafter	9. Beam	11. Brace	13. Zinc Sheet
2. King Post	4. Ridge Purlin	6. End Purlin	8. Angle Rafter	10. Tie Beam	12. Roof Board	14. Brick Chimney

Figure 3.23 Traditional Roof Construction (Şahin, 1995:201)

CHAPTER IV

THE BEHAVIOUR OF TRADITIONAL TIMBER BUILDINGS AGAINST EARTHQUAKE

4.1 Definition of the Earthquake Phenomenon

Earthquakes have affected human life since the beginning of the history. An earthquake is the sudden, sometimes violent movement of the earth's surface from the release of energy in the earth's crust. Earthquakes happen along the edge of the tectonic plates that move and push against each other. M. E. Tuna notes that the records about earthquakes date back to 2000 B.C. Aristotle (born 384 B.C.) made researches and classifications about earthquakes (Tuna, 2000).

If the crust of the earth is subject to tectonic forces, it bends lightly. However, because the crust is rigid, when the stress or pressure exceeds the strength of the rocks, the crust breaks and snaps into a new position. Vibrations called seismic waves are generated and travel both through the earth and along its surface. These seismic waves cause the earthquakes. Larger earthquakes usually begin with slight shake but rapidly take the form of more violent shocks. Then they end in vibrations of gradually diminishing force called aftershocks.

The underground point of origin of an earthquake is called its focus; the point on the surface directly above the focus is the epicenter. The earthquake is felt the most intense at this point. The amount of damage is very high near the epicenter. Actually, the epicenter is also an area rather than a point. The size of this area is related with the magnitude of the earthquake. Sometimes, even though the magnitude is small, the damage can be great in the epicenter area (Özmen, 2002).

Furthermore, the magnitude is a measurement of the released energy during an earthquake. For measuring the amount of energy seismographs are used. A seismograph combines a seismometer that senses the earth's motion, with recording equipment to obtain permanent record of the motion. After measuring the ground motion, a chart is produced, called Richter scale. In this chart 10-based logarithmic rates of the maximum amplitude values are indicated. The Richter magnitude scale was developed in 1935 by Charles F. Richter of the California Institute of Technology as a mathematical device to compare the size of earthquakes.

On the other hand, the intensity of an earthquake is measured by subjective criteria such as the effect on people, the amount of damage on buildings, the effect on landscape. Intensity scales have been used since 19th century. Generally Modified Mercalli Scale is used in Turkey. The major earthquakes of 20th century in the world and also the major earthquakes in Turkey between 1509 and 2002 are shown in Table A.1, Table A.2 in Appendix A. In addition to these earthquakes in 2003 an earthquake occurred in magnitude 6.00 in Bingöl. This earthquake caused large amount damage on rural dwellings. Although earthquake is a natural event, it easily turns into calamity by the collapse of man-made environment (Figure 4.1). There is no known way to hinder earthquakes, but it is possible to reduce the impact of them. The amount of devastation from an earthquake can be

greatly decreased by using earthquake resistant building design, choosing correct materials for constructions, making the design as a team work with both engineers and architects and educating people about earthquake safety.

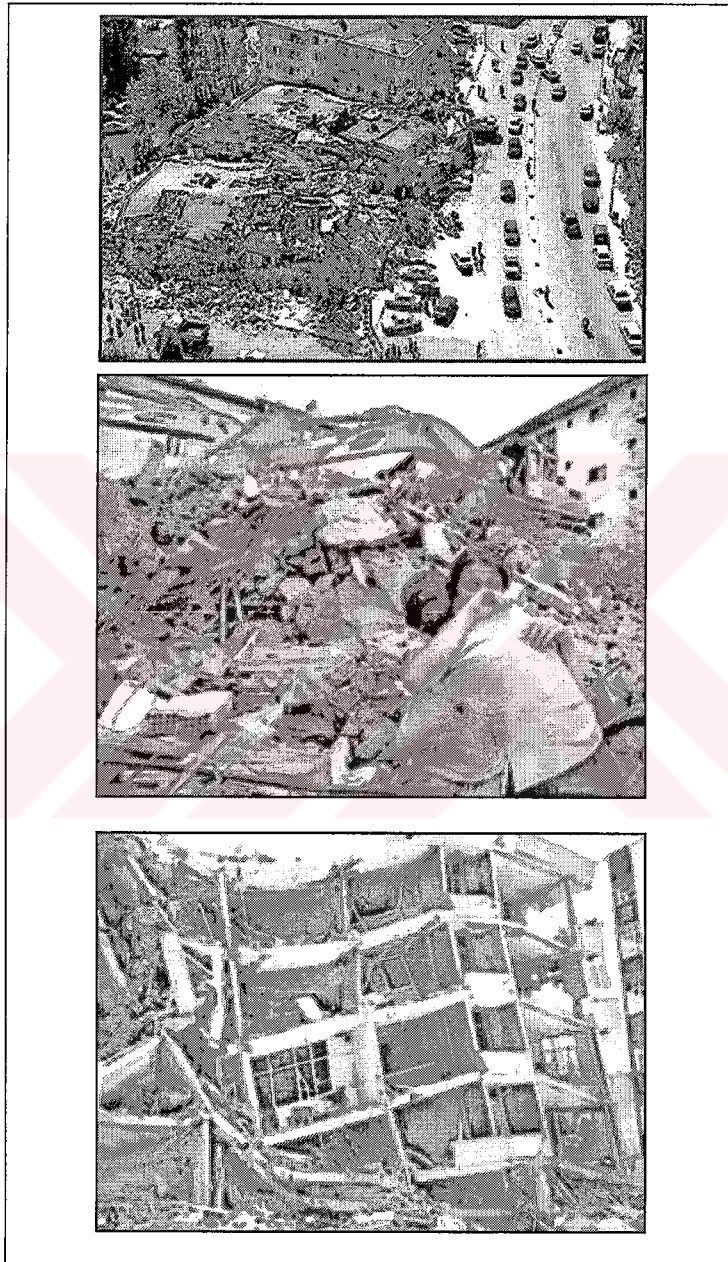

Figure 4.1 Earthquake Photos from Different Cities

http://www.glaciermedicaled.com/Earthquake_html/EQ_world/turkey2.jpg

4.2 Seismic Effects on Structures

4.2.1 Inertia Forces in Structures

Earthquake causes shaking of the ground on which buildings rest. Therefore, buildings experience motion at their bases. From Newton's First Law of Motion, while the base of the building moves with the ground, the roof has a tendency to stay in its original position. However, since the walls and columns are connected to roof, they haul it along with them (Figure 4.2). As a result, this tendency to continue to remain in the previous position is called inertia. Certainly, the heavier the building the more inertia has to be overcome. Thus, lighter buildings sustain the earthquake shaking better.



Figure 4.2 Effect of Inertia in a Building When Shaking at its Base

<http://www.indianpurchase.com/magonline/construction>

4.2.2 Effect of Deformations in Structures

The inertia force is transferred to the ground by the columns, causing forces in columns. During earthquake shaking, the columns undergo relative movement between their ends as shown in Figure 4.3. However, columns would like to come back to the straight vertical position in which the columns carry no horizontal earthquake force through them. But, when forced to bend, they develop internal forces. If the horizontal displacement between the top and bottom of the column increases, internal force in columns rises. For this reason, these internal forces in the columns are called bending forces.

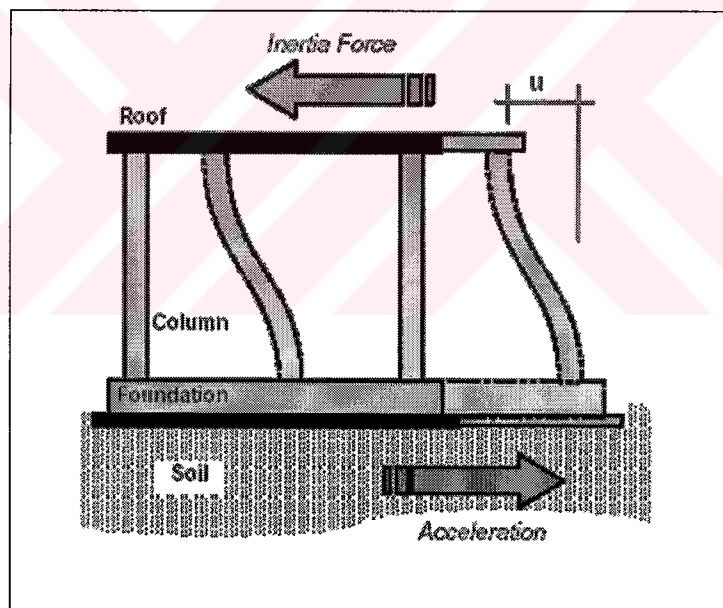

Figure 4.3 Inertia Force and Relative Motion within a Building
(<http://www.indianpurchase.com/magonline/construction>)

4.2.3 Horizontal and Vertical Shaking

Earthquake causes shaking of the ground in all X, Y and Z directions. In addition, during the earthquake, the ground shakes randomly back and forth along each of these directions. All structures are primarily designed to carry the gravity loads, mass because of own weight and imposed loads that are in vertical (Z) direction. Since factors of safety are used in the design of structures to resist the gravity loads, usually most structures tend to be adequate against vertical shaking. On the other hand, horizontal shaking along X and Y directions remains a concern. The effects of horizontal earthquake shaking may not be safely sustained by the structures designed for gravity loads. Hence, it is necessary to ensure adequacy of the structures against horizontal earthquake effects.

4.2.4 Flow of Inertia Forces to Foundation

Horizontal inertia forces are generated at level of the mass of the structure. The floor slabs transfer these lateral inertia forces to the walls or columns, to the foundations, and finally to the soil (Figure 4.4). Therefore, to provide the transfer of these inertia forces safely, floor slabs, walls, columns, foundations and the connections between them must be designed carefully. Walls or columns are the most critical elements in transferring the inertia forces.

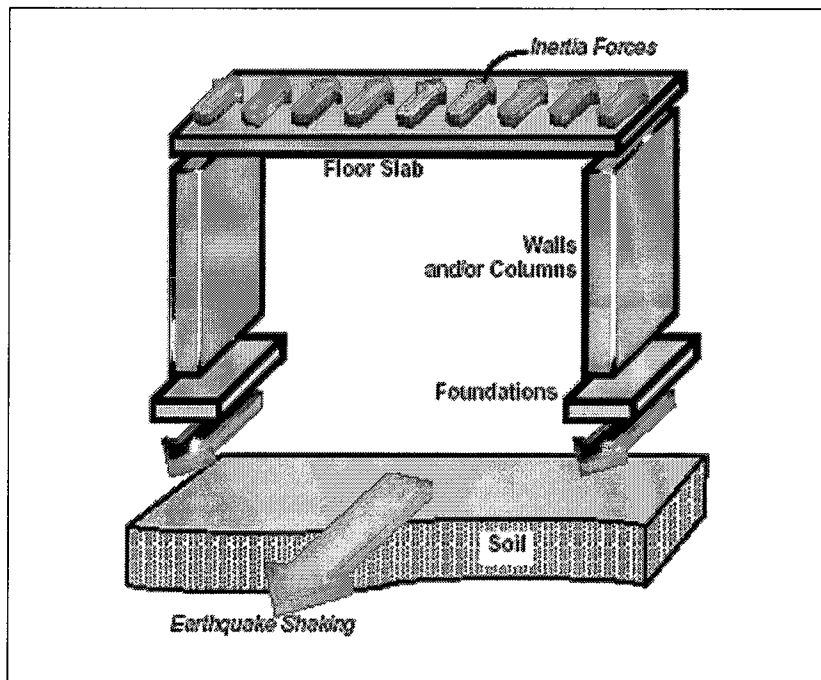

Figure 4.4 Flow of Seismic Inertia Forces Through All Structural Components

(<http://www.indianpurchase.com/magonline/construction>)

4.3 Observations on Behaviours of Traditional Timber Buildings in Past Earthquakes

In every year there are occurring more than a hundred earthquakes that have the magnitude of at least 5.0 in the world. 92% of our country is also in the earthquake zone according to earthquake map. In other words, 95 % of Turkey population lives under danger of earthquakes. It is reported that in the last 58 years 58.202 people died, 122.096 people injured in Turkey because of earthquakes. Moreover, nearly 411.465 buildings collapsed or severely damaged. Consequently, it can be said that every year average

1.003 people die and 77.094 buildings collapse in Turkey due to earthquakes.

Turkey suffered two disastrous earthquakes in 1999, on August 17, 1999 and again on November 12th of the same year. Earthquakes measured 7.4 and 7.1 on the Richter scale, respectively; hit Turkey in areas east of Istanbul. The first earthquake, which occurred on August 17, rocked the Marmara Region and has been followed by as many as 5,000 aftershocks. Some of these aftershocks have registered as much as 5.5 to 6.0 on the Richter scale. The latter earthquake, on November 12, 1999, was further to the east and centred on Düzce. The earthquake took place along the Düzce Fault Zone and caused damage in the areas of Düzce, Kaynasli, Bolu, Akcakoca, Zonguldak and Adapazari.

(http://www.umcor-ngo.org/english/countries/turkey_1.htm)

In the studies for these two earthquakes in Turkey, it was observed that structural damage and life loss are more in structures, which were constructed with today technology in comparison to the traditional ones. Therefore, many traditional timber buildings that were constructed without engineering design have performed well during past earthquakes. This could be attributed to the following characteristics:

- High strength-to-weight ratio of wood material.
- High ductility and energy dissipation capacity of connections.
- Light mass being supported by the system.
- Symmetrical plan layouts.

Erman (2002:88) states that there are some requirements in order to construct a timber building in an earthquake zone as following:

- The carrier walls of the timber structures must be regular, and according to the centre of porter system they must balance each other. In earthquake zones, timber buildings can be designed as maximum two floors except basement.
- The basements of the wooden houses can be built with stones or bricks. This kind of building is an old tradition of Anatolia.
- In the walls of the structures built with stones and bricks, horizontal tie beams (TR: Hatıl) must be used and in necessary locations (corners of the buildings, span edges, etc...) vertical ridge plate must be designed. The rules, defined for masonry buildings are also valid for the other details of the walls of structures built with stones or brick.
- Lengths of free timber walls, which are carrier, should not be longer than 4.5 m. If this limit is exceeded, in order to provide stability of the wall there must be constituted with intersecting walls or the connections of the wall with flooring and ceiling slices must be strengthened.
- The cross-sections of posts with 40-60 intervals are 5x10 cm in single storey timber structures. If the interval between the posts is 60-80 cm the cross-sections of them should be 10x10 cm. The dimensions of wall plate and footplate should be 10x10 cm, whereas in two storey structures these dimensions should be 6x12 cm or 12x12 cm.

- The interval between the corners of the building, doors and windows should be 1.5 m. In addition between window and door there should be 75 cm space as shown in Figure 4.5.

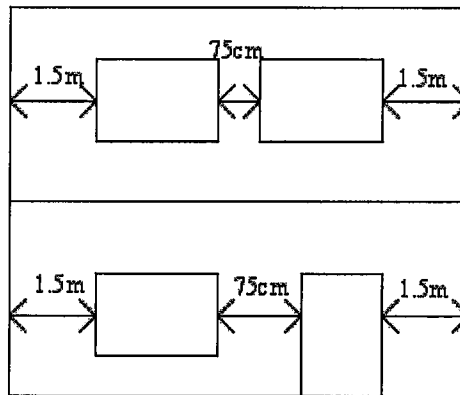

Figure 4.5 Intervals Between Window and Door

- The foundations of timber structures should be continuous or raft foundation according to ground conditions.

Timber buildings with different construction styles can act differently from each other when subjected to earthquake. It is clear that many factors influence the performance of a timber framed structure during an earthquake such as the soil quality of the site, the structural, architectural and material characteristics and features of ground movement at the building site. The typical properties of earthquake damage to wooden buildings are as follows:

- The failure commonly occurs at the joint connecting the column and girder.
- In two storey structures, generally the first storey suffers more damage.

- Damage due to the differential settlements of foundations is observed in the wooden buildings that stand on soft ground.
- Cracking of the wall finishing and slight distortion of structural frame are observed.

Dowrick (1987) states the main causes of inadequate performance of timber construction in earthquakes are as below:

- Large response on soft ground
- Lack of integrity of substructures
- Asymmetry of the structural form
- Insufficient strength of chimneys
- Inadequate structural connections
- Use of heavy roofs without appropriate strength of supporting frame
- Deterioration of timber strength through decay or pest attack
- Inadequate resistance to post-earthquake fires (Dowrick, 1987).

In spite of these failures, most traditional timber framed buildings had little damage and did not cause too much life loss in the latest earthquakes, whereas many of their modern counterparts collapsed in same earthquakes. Gülhan and Güney who conducted a statistical study in several areas of earthquake zones confirmed this finding. They found a wide difference between traditional timber construction that collapsed and modern buildings. Gülhan and Güney documented that in one district in Gölcük, 60 of the 814 reinforced-concrete, four-to-seven-story structures, collapsed or were heavily damaged. However, only 4 of the 789 two-to-three-story traditional structures collapsed or were heavily damaged. The reinforced-concrete buildings accounted for 287 deaths against only 3 in the traditional structures. In the heart of the damage district in Adapazari, where the soil

was poorer, this research shows that, 257 of the 930 reinforced concrete structures collapsed or were heavily damaged and 558 were moderately damaged, while none of the 400 traditional structures collapsed or were heavily damaged and 95 were moderately damaged (Gülhan and Güney 2000).

According to Stephen Tobriner (2000), Turkish houses have features which unite them with antiseismic construction elsewhere. The most obvious is that they are made of wood. The property of wood to be flexible without breaking and to return after bending to its former shape makes it an ideal construction material in earthquake country. If beams and columns are sufficiently strong and flexible, braced and tied together to work as units, wooden walls can resist the lateral forces induced by earthquakes. Although the spaces between the timber frames may be filled with adobe, brick or simply left vacant, the wooden skeleton of the Turkish house can stand on its own as a self-supporting system. The timbers are simply nailed together but the framework is stabilized by the use of diagonal braces.

During an earthquake, to resist lateral movement the frame must have diagonal or x bracing as shown in Figure 4.6. Since corners are the most vulnerable to damage in earthquake, the diagonals have been positioned there. Stephen Tobriner emphasized that the more diagonal bracing the better. There is also an art to placing and designing diagonal bracing. The wider the base of the triangle in relation to its height the stronger it is. The diagonal should be connected to the vertical member as close to the joint with the horizontal member of the panel as possible.

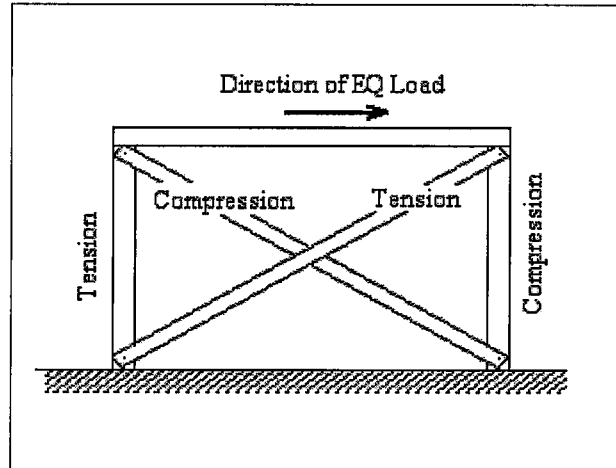

Figure 4.6 X Bracing

An important additional factor for the performance of traditional timber structures' walls that was stated by Randolph Langenbach (2003) is that the traditional structures can withstand many cycles of shaking by dissipating energy through the friction of their component parts. There are no strong and stiff elements to attract the full lateral force of the earthquake in this flexible frame construction. Therefore, the buildings survive the earthquake by not fully engaging it. During an earthquake this working can continue for a long period before destructive level.

4.3.1 Traditional Timber Building in the Marmara Earthquake of August 17, 1999

The Marmara earthquake (also called the Kocaeli earthquake) of August 17, 1999 killed approximately thirty thousand people (Kandilli, 2000). The epicenter was just 200 kilometers east of Istanbul as shown in Figure 4.7 (<http://www.koeri.boun.edu.tr/depremmuh/>). In some areas of Gölcük and

Adapazari, the earthquake destroyed more than a third of all housing units, almost all of them in reinforced concrete buildings (Gülhan and Güney 2000). There were clusters of *hımış* buildings in the heart of these districts. These houses, mostly dating from the early part of the twentieth century, pre-dated the ruined reinforced-concrete apartment blocks nearby. Many of the older *hımış* houses remained intact, but a few were heavily damaged some of which is indicated in Figure 4.8.

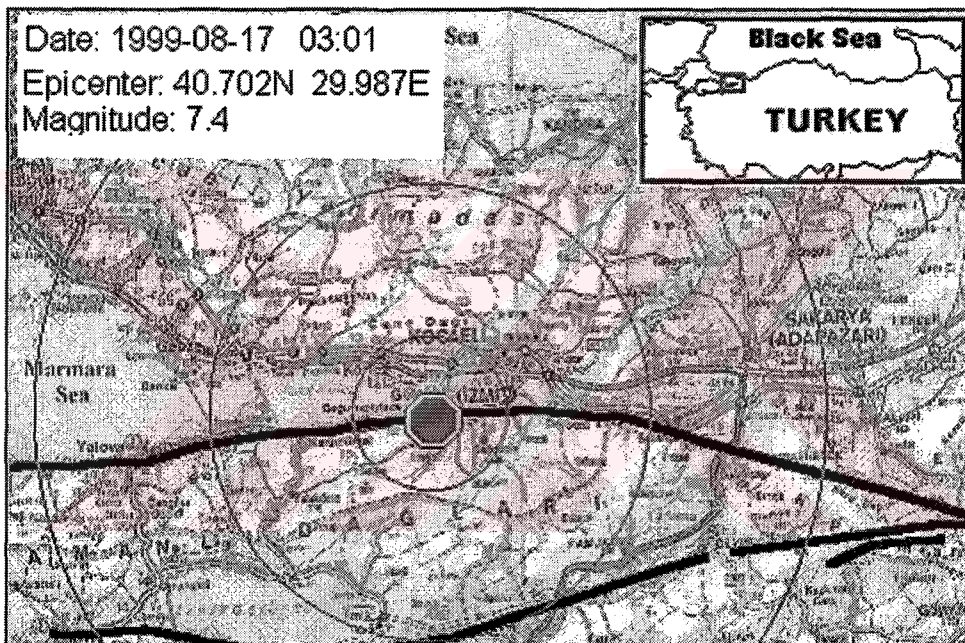
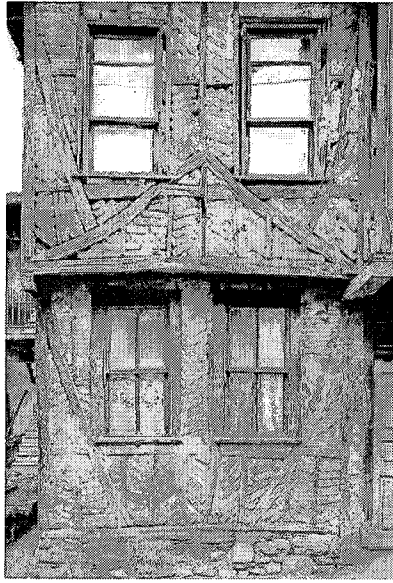
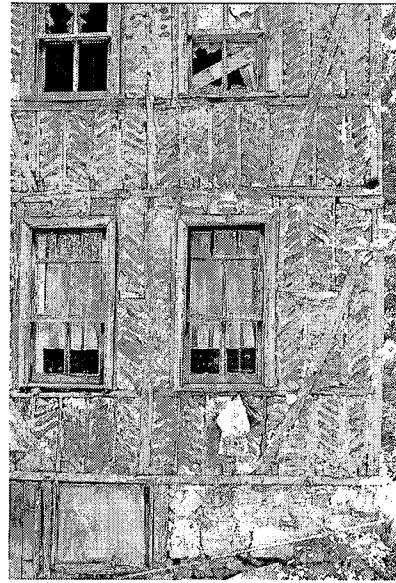

Figure 4.7 Epicenter of Kocaeli Earthquake
(http://www.eas.slu.edu/Earthquake_Center/TURKEY/)



Gölcük

(Langenbach, 2002)



Gölcük

(<http://www.icomos.org/iiwc/seismic-i.html.en>)

Figure 4.8 Hımsı Structures After Earthquake

Randolph Langenbach (2002) pointed out that in one area surveyed in Adapazari a single hımsı house collapsed, killing an occupant. A rare occurrence of a death caused by the collapse of hımsı construction. Decayed timbers could be seen in the ruins. It was the partially damaged traditional buildings here and in Gölcük provided evidence of how this type of construction responded to earthquake forces. Once each building was inspected, and the damaged area in each building identified, a pattern began to emerge. Of those inspected where structural damage was found, most of the damage was concentrated at areas around rotted timbers. Interviews with residents often revealed that the buildings with the most timber decay had been unoccupied for years. It appeared that decayed timber significantly

degraded a buildings' performance in earthquakes. In occupied houses, the most severe damage resulted mainly from alterations and modernization work that had corrupted the integrity of the original frames and walls (Langenbach, 2002).

In addition to Adapazari, there are examples of traditional timber buildings which are still standing, have been surrounded by failed concrete buildings in Değirmendere. The wood frame here is infilled with wattle and daub and they are lighter than the structures with brick and rubble infill. In these earthquake areas, results of the surveys show that the performance of the wood framed houses in earthquake was impressive.

4.3.2 Traditional Timber Building in the Düzce Earthquake of November 12, 1999

Three months after the 17 August event, Mw 7.2 Düzce earthquake ruptured another 40 km segment of the same fault, which was broken during the Kocaeli earthquake, toward further east. Düzce, a city with a population of 78,000 has almost been devastated as a result of two consecutive earthquakes. Kaynaşlı and Bolu were also affected significantly from the Düzce earthquake (Figure 4.9). The epicenter of the Düzce earthquake was 6 km south of Düzce(Sucuoğlu, 2000).

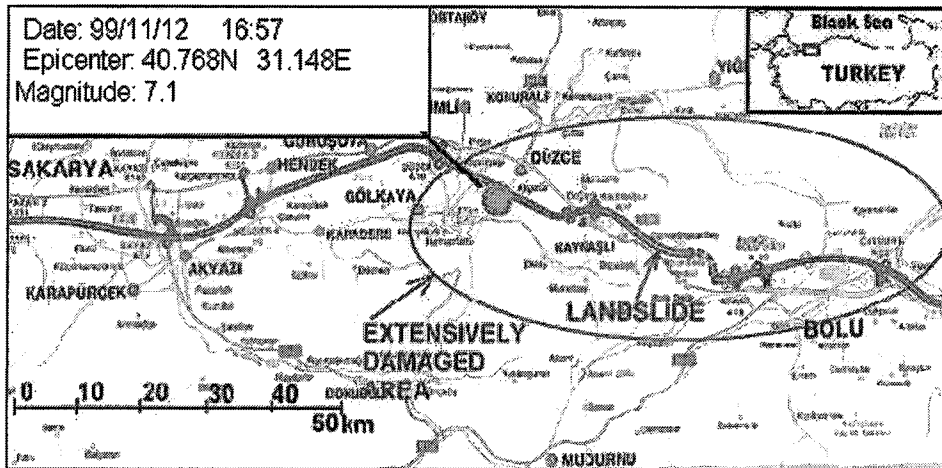
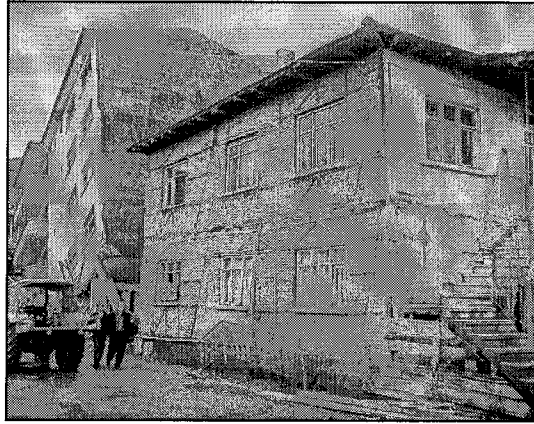
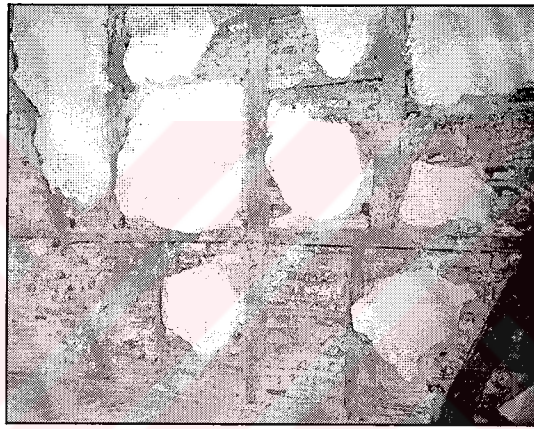

Figure 4.9 Epicenter of Düzce Earthquake (Kandilli, 2000)

Düzce was still recovering from the Marmara earthquake when the second one occurred. Most of the damage is concentrated in Kaynaşlı a small town on the main highway between Düzce and Bolu. Loss of life in Düzce concentrates in few collapsed buildings that were lightly damaged in the August 17 earthquake, superficially repaired and later inhabited (Kandilli, 2000). There are many examples of traditional structures that are still standing after earthquakes as indicated in Figure 4.10. Therefore, during this study, the performance of traditional structures in Düzce has been examined. These buildings have quite simple plan scheme and their windows are placed well in from the corners. Diagonals and x braces, which helps to make structures much more likely resist earthquakes, were placed on each side. In the wood frame, the infill was mostly brick sometimes stone and mud. The analysis of two of them can be seen in chapter 5.



(<http://cires.colorado.edu/~bilham/Duzce.html>)



(Langenbach, 2002)

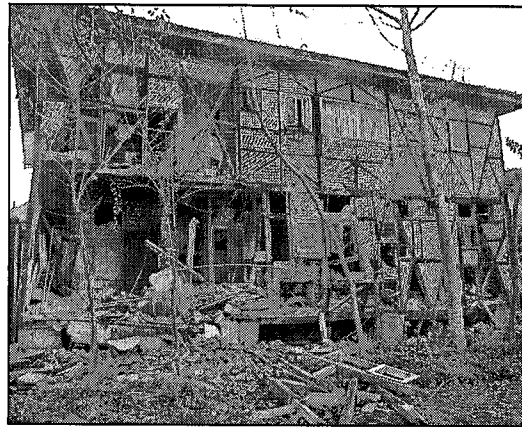

(<http://cires.colorado.edu/~bilham/Duzce.html>)

Figure 4.10 Himiş Structures After Earthquake

4.3.3 Traditional Timber Building in the Sultandağı-Çay Earthquake of February 3, 2002

Erdik, Sesetyan, Demircioğlu, Celep, Biro, Üçkan (2002) explain that an earthquake of magnitude Md 6.0 ($M_w = 6.3$) occurred on February 3, 2002 at 9:11 local time causing damage and casualties at the town of Afyon (population: 183,351) and its provinces (Sultandağı, Çay, Bolvadin, Çobanlar, Suhut, Akşehir). The macro seismic epicenter is located near the Sultandağı province and the earthquake is associated with the Sultandağı fault zone, which is shown in Figure 4.11. Three major aftershocks with magnitudes between 5 and 6 followed the main event. One of those ($M_w = 6.0$, occurred at 11:26 local time) is also considered as another main shock. Total dead count is 43 with 260 injured.

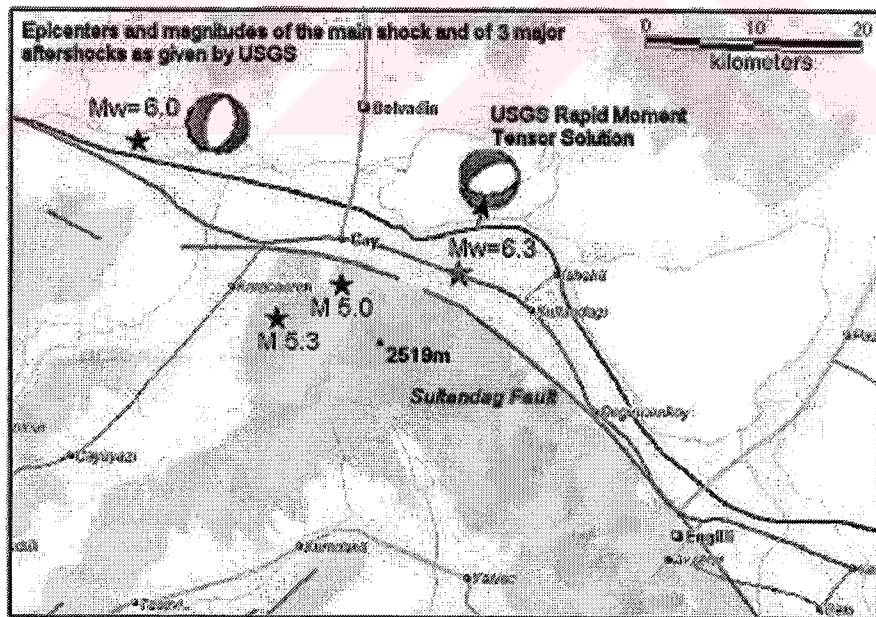

Figure 4.11 Sultandağı Fault Zone

(Erdik, Sesetyan, Demircioğlu, Celep, Biro, Üçkan, 2002)

The Seismic Moment of the Sultandağı Earthquake is about two times that of the Dinar Earthquake. In Figure 4.12 damage distribution is indicated by Erdik, Sesetyan, Demircioğlu, Celep, Biro, Üçkan (2002).

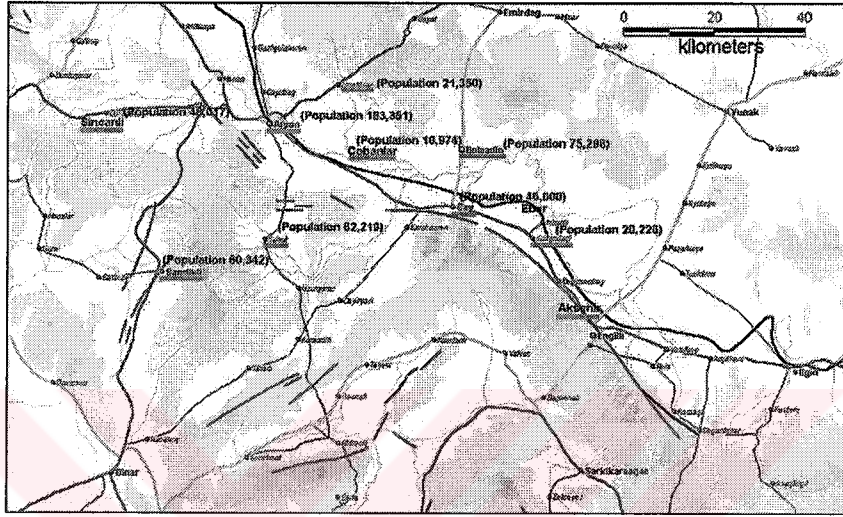

Figure 4.12 Damage Distribution of Sultandağı Earthquake
(Erdik, Sesetyan, Demircioğlu, Celep, Biro, Üçkan, 2002)

In contrast to lateral actions of traditional structures created by Marmara and Düzce Earthquake, wooden houses showed bad performance in Sultandağı Earthquake. Erdik, Sesetyan, Demircioğlu, Celep, Biro, Üçkan, (2002) reported that most of the injuries and casualties in the region are associated with the total collapse of hımsı buildings. Hımsı buildings had been widely preferred in rural areas three or four decades ago and were traditionally built by their residents without engineering considerations. Thick perimeter walls and heavy roofs are common features of hımsı buildings providing heat isolation of the structure. The observed performance level of hımsı buildings indicated heavy damage and total collapse due to the poor strength and brittle behaviour of the walls and considerable mass of the buildings (Figure 4.13). Moreover observation on collapsed buildings indicated that as a consequence

of weak connections between the perimeter and orthogonal partitioning walls, separation occurred and most of the thick perimeter walls collapsed in the out of plane direction (Erdik, Sesetyan, Demircioğlu, Celep, Biro, Üçkan, 2002).

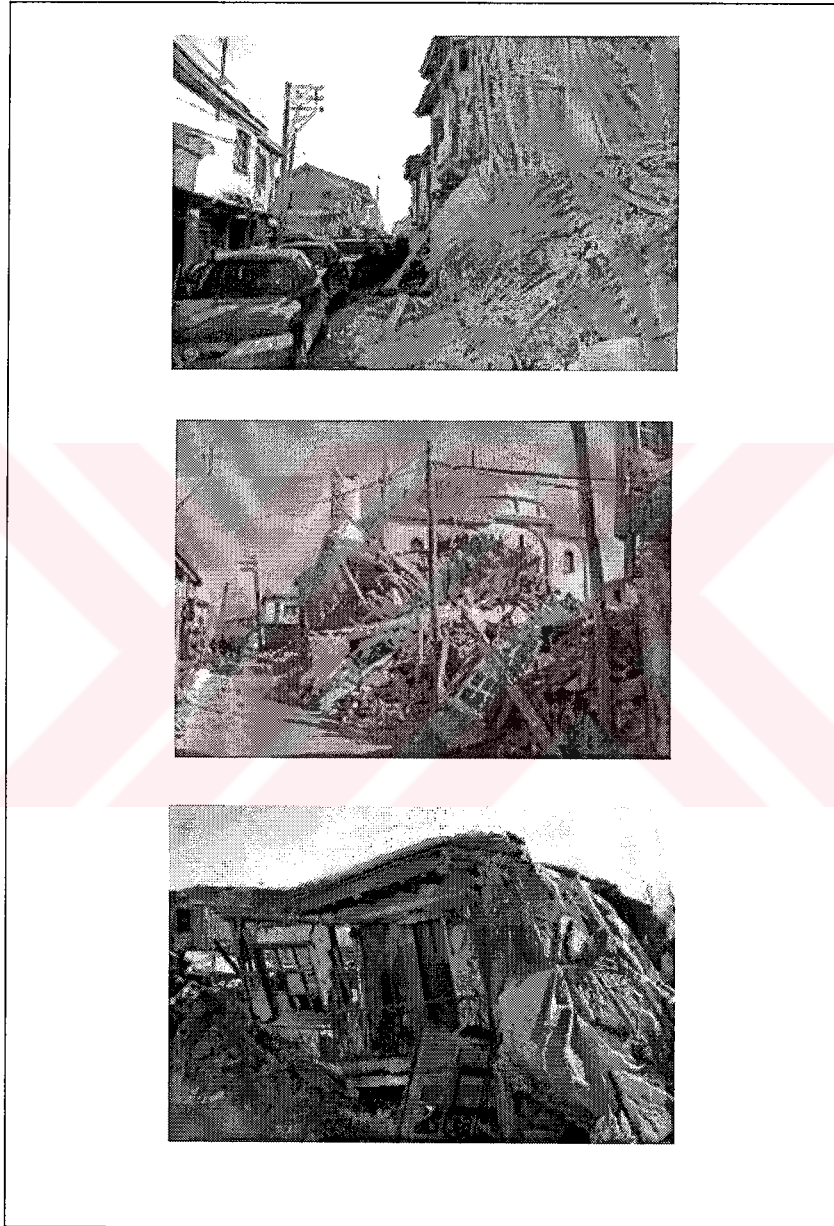
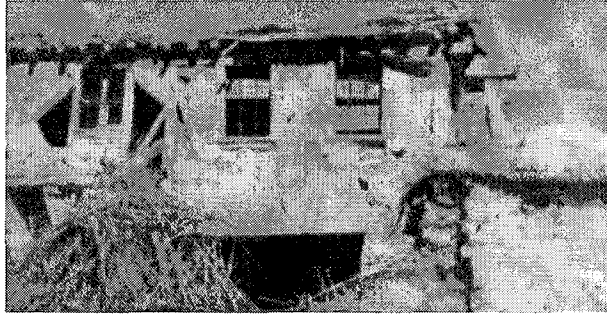
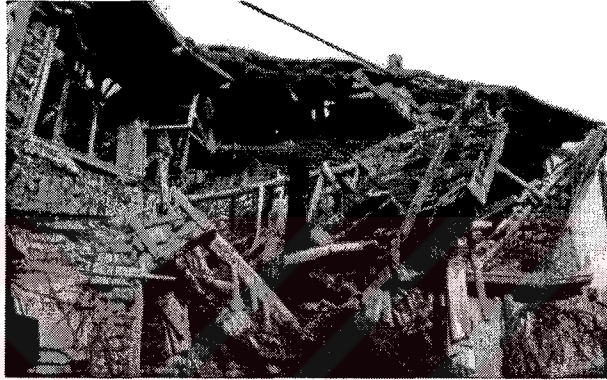

Figure 4.13 Traditional Building Damages in Sultandağı Earthquake
(Erdik, Sesetyan, Demircioğlu, Celep, Biro, Üçkan, 2002)



Yeşilçiftlik



Çobanlar-Sülümenli-Gebeceler

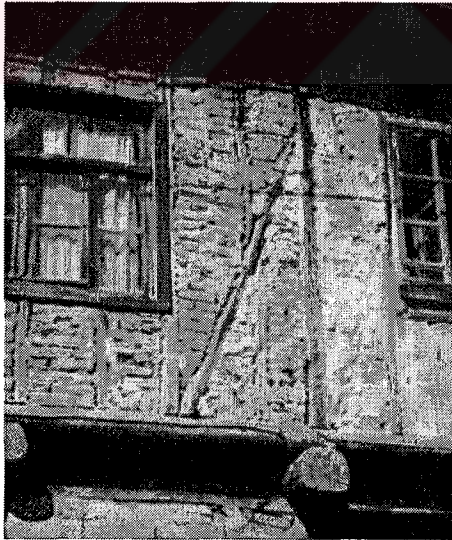

A Himiş Structure Remained Intact

Figure 4.13 Continued (Karaesmen, 2002)

CHAPTER V

EFFECTS OF LATERAL FORCES ON TRADITIONAL TIMBER BUILDINGS: A CASE STUDY

5.1 Objective

It has been previously mentioned that one of the aim of this thesis is to examine the seismic behaviours of traditional timber buildings. Traditional construction techniques used in timber-framed buildings have shown good performance in past earthquakes. Therefore, these structures can be the key for many solutions for the houses that will be built in the future. In this chapter to observe the characteristics of traditional structures, which provide earthquake resistance, 3D models are generated for computer analysis. The analyses of the cases from Gölyaka are carried out by finite element analysis and the behaviour of the humuş and bağıdadi type structures under gravity and lateral forces are examined.

5.2 Definition of the Computer Analysis Technique

Finite element method is based on representation of the structure as a finite number of lines and two or three-dimensional minor classes called as finite elements. The intention beyond this is to convert the problem with infinite

number of degrees of freedom, to one with a finite number. Accuracy of the analysis depends on the number of elements used in the model. Then, geometrical properties of each of the individual elements are determined. Stress-strain relationships and stiffness within a typical element are calculated, which are subsequently to be calculated within each element (Toker, 2000).

The structural modelling of the cases is generated for SAP2000 software. While modelling, the structures are divided into elements. The analytical model consists of joints, restraints, shell and the loading data. However this study is limited with the structural knowledge of an architect. Therefore to demonstrate behaviours of structures the models are simplified.

The purpose of analytical modelling is to try to represent the actual behaviour of a traditional timber framed structures. The actual behaviour of the structure is usually highly complex hence; many simplifications have to be made in order to model it. In order to achieve the model, supports and connection of elements and the loading has to be defined.

5.3 Definition of the Case Studies

The study is conducted on two types of traditional timber buildings. The first one is hınış with adobe infill and the second one is bağdadi. These cases have been chosen from Gölyaka that is a small town in northwestern Anatolia. The two destructive earthquakes have damaged this town in 1999.

Gölyaka is in the Black Sea Region of Turkey and bears the characteristics of this region (Komisyon, 1999). The topography of the region consists mainly of a high range of steep mountains along the Black Sea. Gölyaka is located on

the Düzce Plain, which is one of the series of basins among mountains as shown in Figure 5.1.

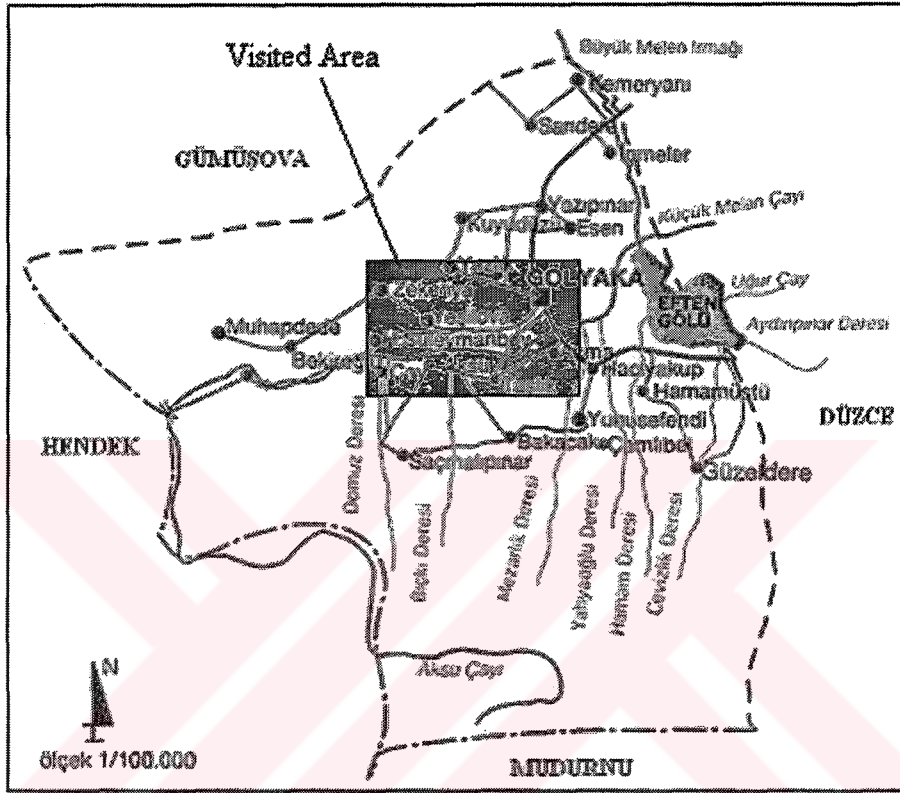

Figure 5.1 The Map of Gölyaka
(Modified From Head Official of Gölyaka, 2000)

The formation of these plains has been attributed to settling due to the activity of the North Anatolian Fault line, or NAF, which spans the north of Turkey from Karlıova in the east into the Marmara Sea in the west. This fault line is liable for frequent seismic activity in this zone as well as the ongoing geologic formation of the area (TUBITAK-MTA-AU, 1999).

The site of Gölyaka is separated from the rest of the plain by Büyük Melen River and Lake Efteni. The ground on which Gölyaka is situated consists of young alluvial deposits, which is quite unstable under seismic conditions (Bedel, 2002). The fault lines around Gölyaka are indicated in Figure 5.2.

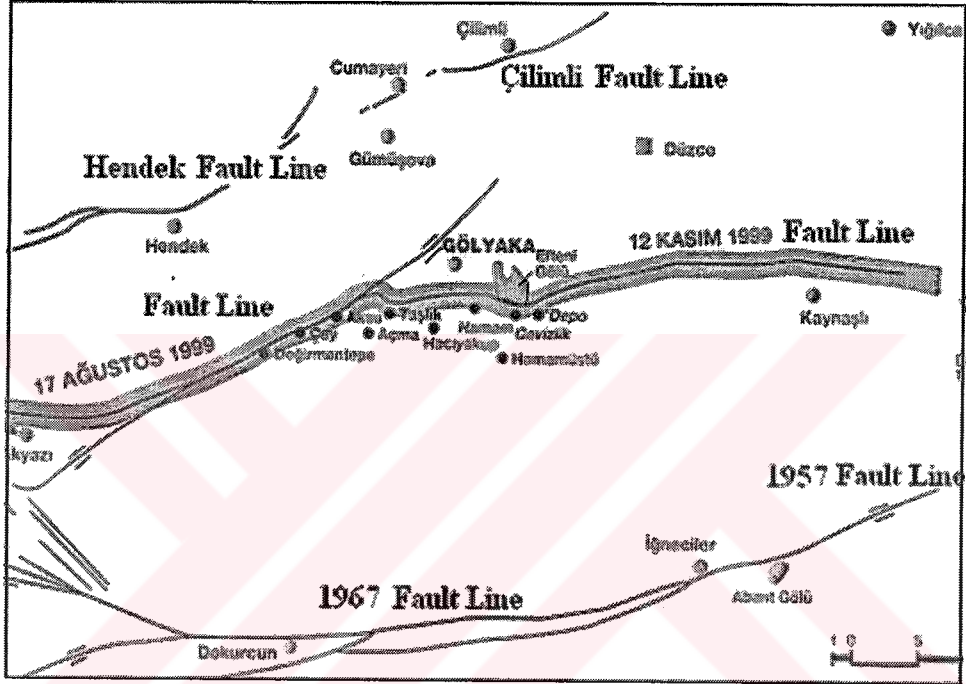

Figure 5.2 The Fault Lines Around Gölyaka
(Modified From Head Official of Gölyaka, 2000)

The town of Golyaka is surrounded by villages, which are Açma, Aksu, Bakacak, Bekiroğlu, Çamlıbel, Çay, Değirmendere, Esen, Güzeldere, Hacı Sülemanbey, Hacı Yakup, Hamamüstü, İçmeler... The case study is chosen from the village of Hacı Süleyman Bey. Some examples of traditional structures from Gölyaka are indicated in Figure 5.3.

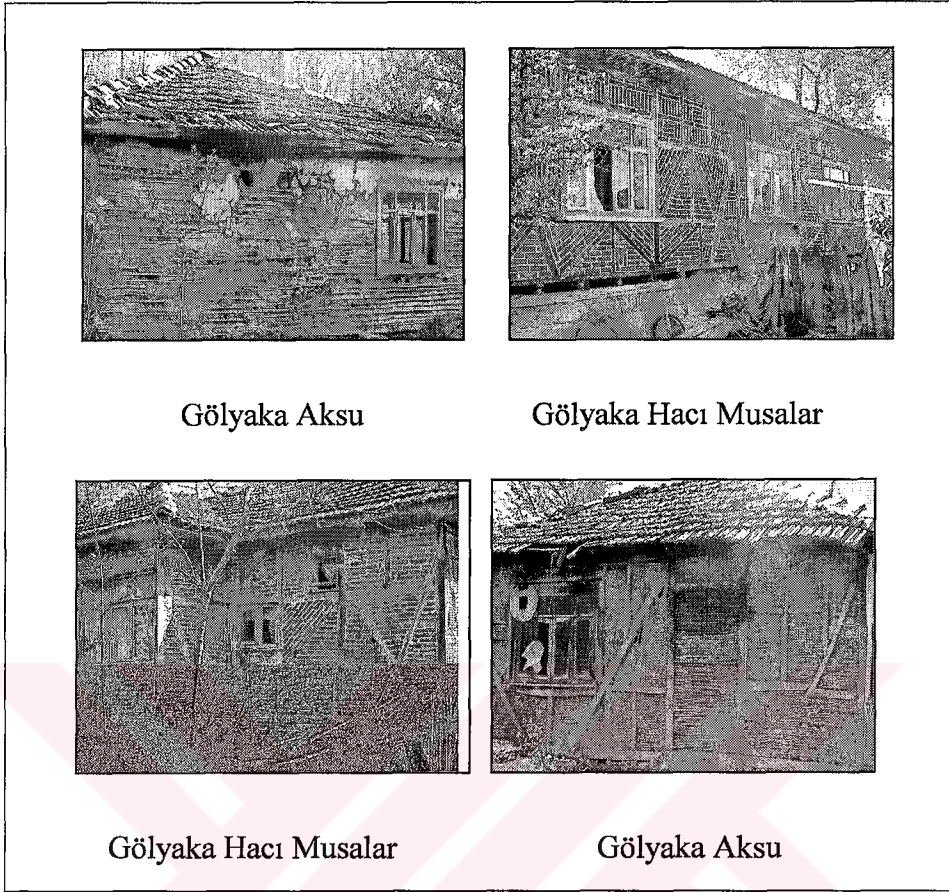

Figure 5.3 Some Examples of Traditional Structures From Gölyaka

The case study from Hacı Musalar village of Gölyaka is a hımış structure with brick infill as shown in Figure 5.4. To compare the seismic performance of hımış and bağdadi, the same building is assumed to be made of with bağdadi system. The self-weight of structural elements and infill materials are included into the calculations. Furthermore, the earthquake loads are applied in two directions X and Y.



Figure 5.4 The Case Study (Hacı Musalar-Gölyaka)

5.4 Computer Models of the Case Studies

The model, which is chosen as the case study, has a square shape with 9x9 m dimensions and 5.4 m height. The thickness of the main posts, beams and braces is taken, as 150 mm while that of the studs is 100 mm. The elements representing the tie beams and laths have a range of thickness between 50 mm and 100 mm. The walls and floors of the structures are modelled with shell elements whereas frame elements are used to model the beams, posts, studs, tie beams etc.

Initially, in order to obtain the accurate structural behaviour, 3-D models of cases are prepared according to actual cross-sections of all elements of framed systems and the rules of analytical modelling. These 3-D models can be seen in Figures 5.5-5.21. 689 joints, 1431 frame elements and 1087 shell elements are used for himiş structure's model while 3087 joints, 5167 frame elements and 92 shell elements are used for bağdadi structure's model.

In the analysis three different structures are examined. Dimensions for himiş structure with adobe infill are determined in the field survey. Initially, a model for himiş type of structure has been developed according to measurements of the field survey. To perform the study in a comparative manner, the dimensions of the rest of the models are adopted in accordance with those of the first model, which is an example of himiş type of structure with adobe infill. The second one is model of bağdadi structure, which does not include any infill between structural members. Therefore shell elements have been used only for floors. The modelling of the third one is also bağdadi structure, however in this type, spans between the structural members are filled with a loose material that has a smaller modulus of elasticity than adobe infill. These structure types can be seen in Figures 5.5, 5.6, 5.7, 5.12, and 5.13.

Firstly, to test the accuracy of the models and to determine the general behaviour of traditional timber frames, the analyses are performed under gravity forces as mentioned before. According to results of the analyses, it could be said that accurate structural behaviours are obtained with these 3-D models. Secondly, the cases are analysed under the lateral forces. In these analyses, 40 % of weight of the buildings is applied as lateral force in X and Y directions. According to these results, 0.524 mm and 0.514 mm displacement are observed on the joints 307 and 325, respectively in the model of himiş structure with adobe infill (Figure 5.8, 5.9). However, the amounts of displacements show a severe decrease in the bağıdadi type structure without infill. 0.267 mm displacement is observed on the joint 731 and 740 (Figure 5.14, 5.15). In the bağıdadi structure with infill 0.247 mm displacement is seen (Figure 5.18, 5.19). Results of the analysis are summarized in Table 5.1. Structural configurations of all the models are quite different from each other. Himiş structure is almost three times heavier than bağıdadi structure due to its construction system and infill material. Thus, distribution of internal forces under lateral loads cannot be compared. Among these models to see the typical moment diagrams and axial force distributions of these structures under lateral loads are indicated in Figures 5.10, 5.11, 5.16, 5.17, 5.20, 5.21.

Results of the analyses show that bağıdadi structures have responded lateral forces better than himiş structure. The reason for this difference could be claimed as the serious increase in weight due to the adobe infill of the himiş structure. Furthermore, in himiş structures disintegration starts in infill material when it is exposed to dynamic reversing actions (Figure 5.22). The first bağıdadi structure with empty spans between the structural members is lighter than himiş structure as observed in the field study. In the other bağıdadi structure, the spans are filled with infill material, which is lighter than those of the himiş structure. In addition to these, nails used in bağıdadi structures provide more energy dissipation.

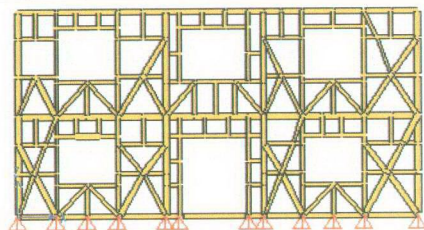

Himış Type of Building

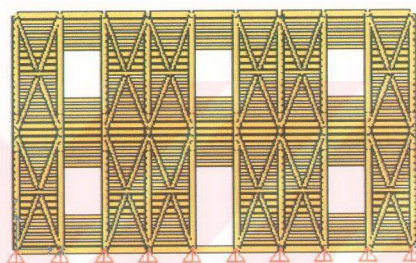

First Bağdadi Type of Building

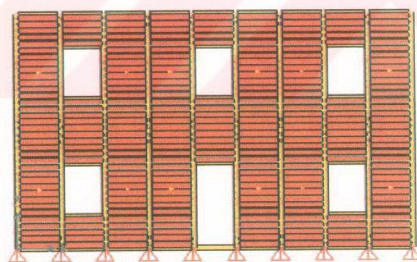

Second Bağdadi Type of Building

Figure 5.5 Construction Systems of Himiş and Bağdadi Structures

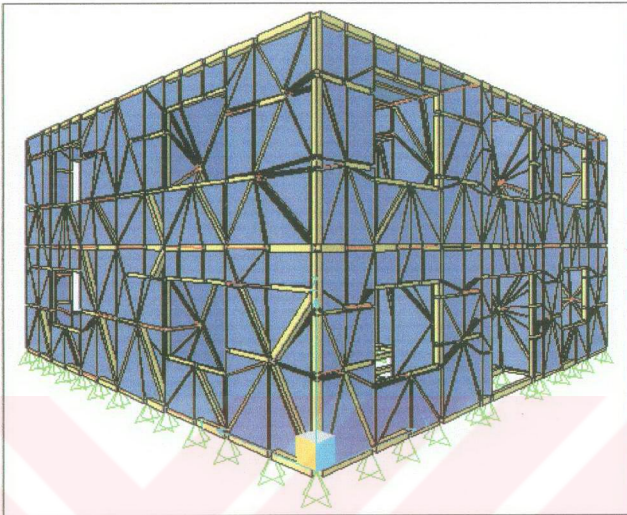

Figure 5.6 Undeformed Shape of Himiş Structure Without Infill Material

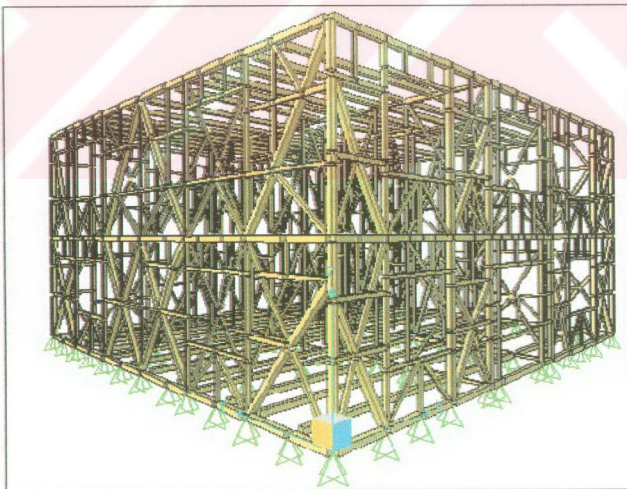

Figure 5.7 Undeformed Shape of Himiş Structure With Infill Material

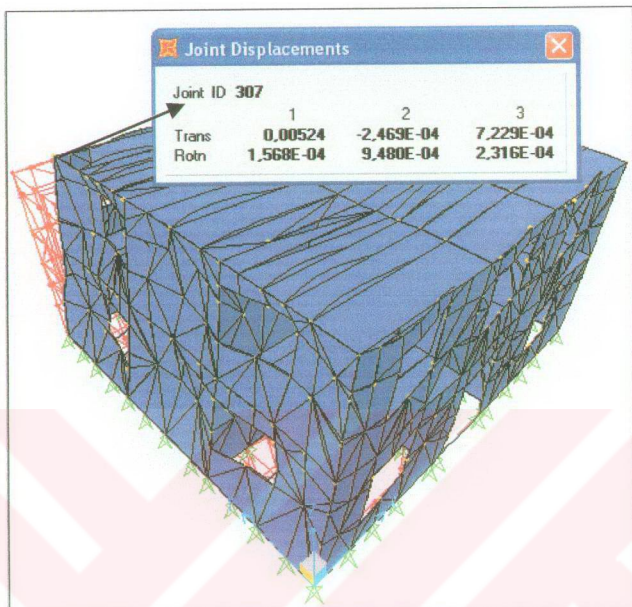

Figure 5.8 Deformed Shape of Hmuş Type of Building

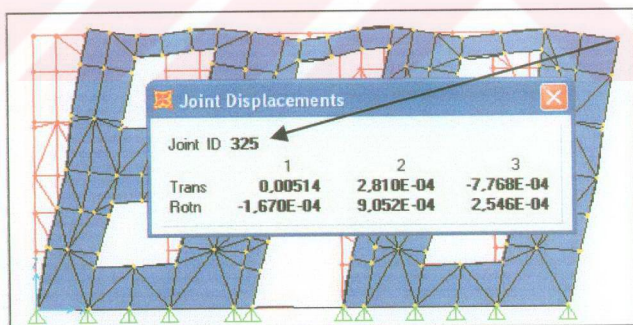

Figure 5.9 Deformed Shape of Hmuş Type of Building

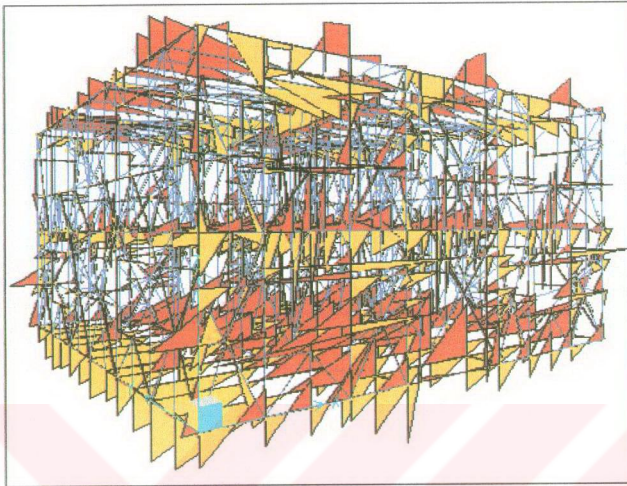

Figure 5.10 Typical Moment Diagram of Himiş Structure Under Lateral Forces

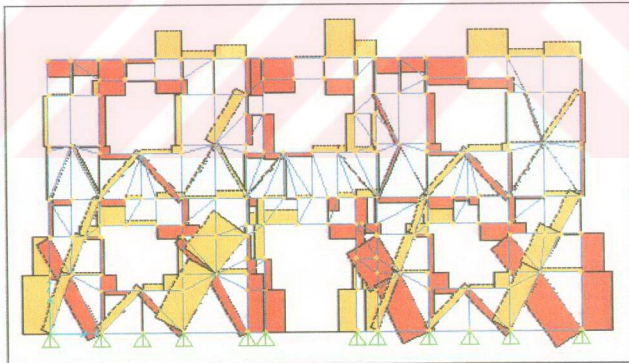

Figure 5.11 Typical Axial Force Distribution of Himiş Structure Under Lateral Forces

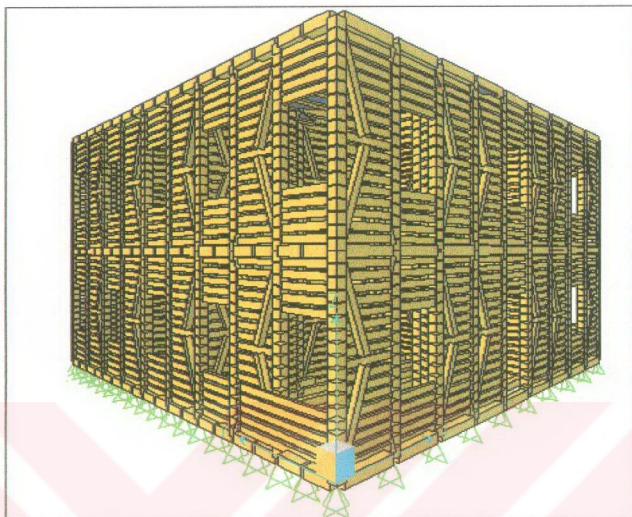

Figure 5.12 Undeformed Shape of Bagdadi Type Building Without Infill

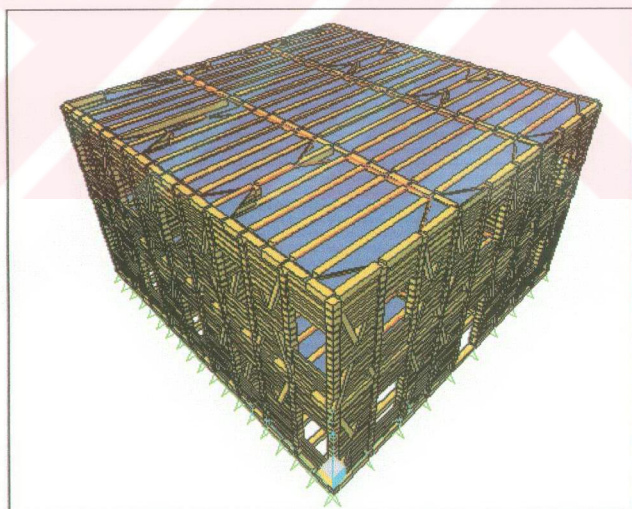

Figure 5.13 Undeformed Shape of Bagdadi Type Building Without Infill

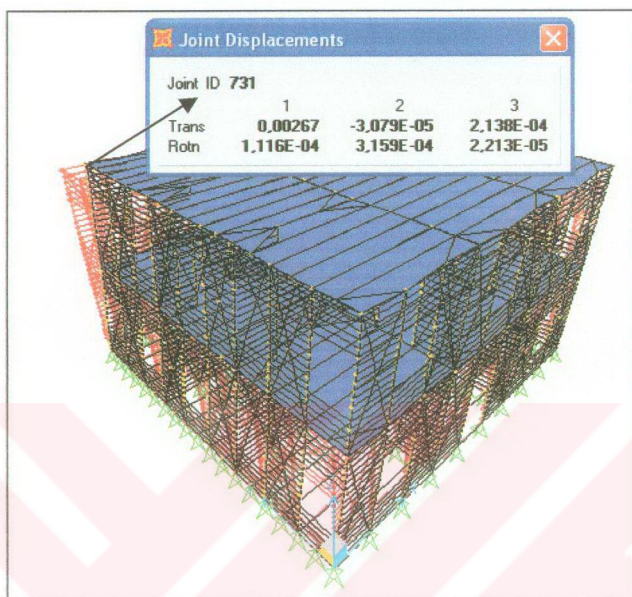

Figure 5.14 Deformed Shape of Bağdadi Structure Without Infill

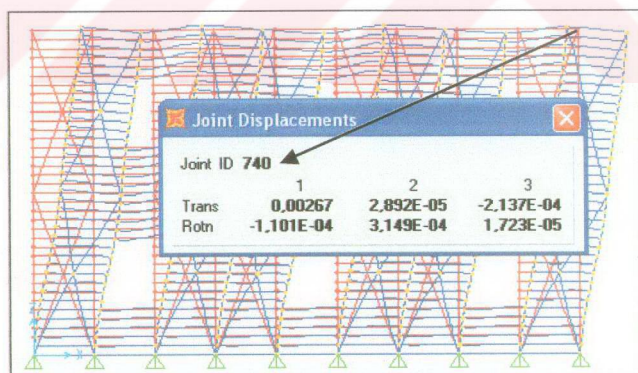

Figure 5.15 Deformed Shape of Bağdadi Structure Without Infill

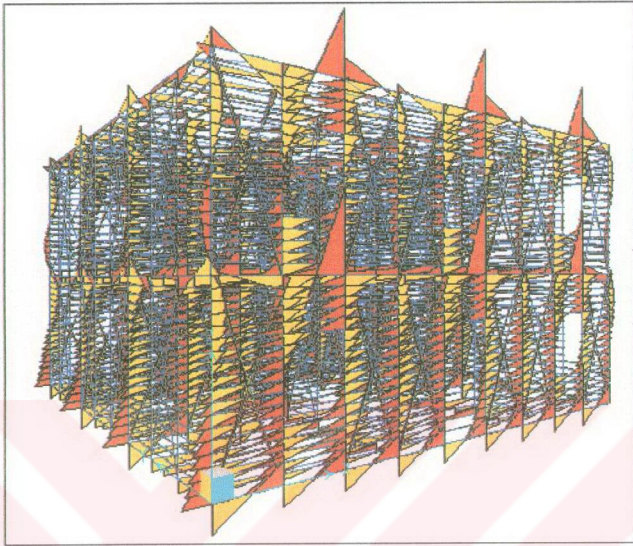

Figure 5.16 Typical Moment Diagram of Bağdadi Structure
Without Infill Under Lateral Forces

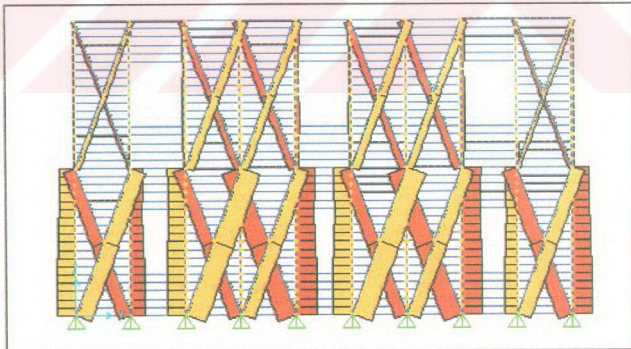

Figure 5.17 Typical Axial Force Distribution of Bağdadi Structure
Without Infill Under Lateral Forces



Figure 5.18 Deformed Shaped of Bağdadi Type Building With Infill

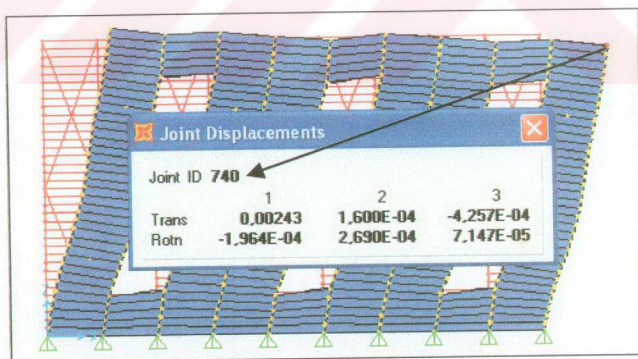

Figure 5.19 Deformed Shaped of Bağdadi Type Building With Infill

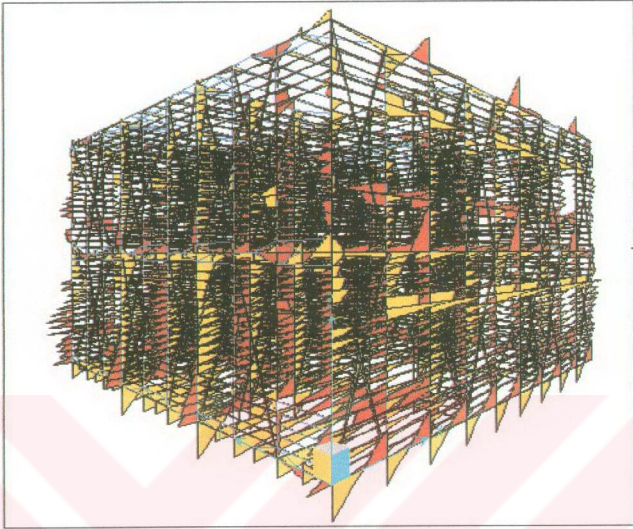

Figure 5.20 Typical Moment Diagram of Bağdadi Structure
With Infill Under Lateral Forces

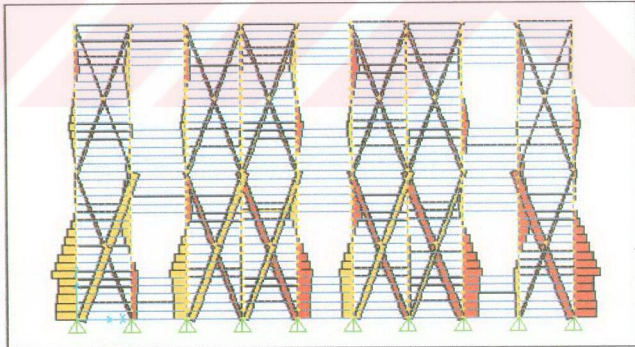

Figure 5.21 Typical Axial Force Distribution of Bağdadi Structure
With Infill Under Lateral Forces

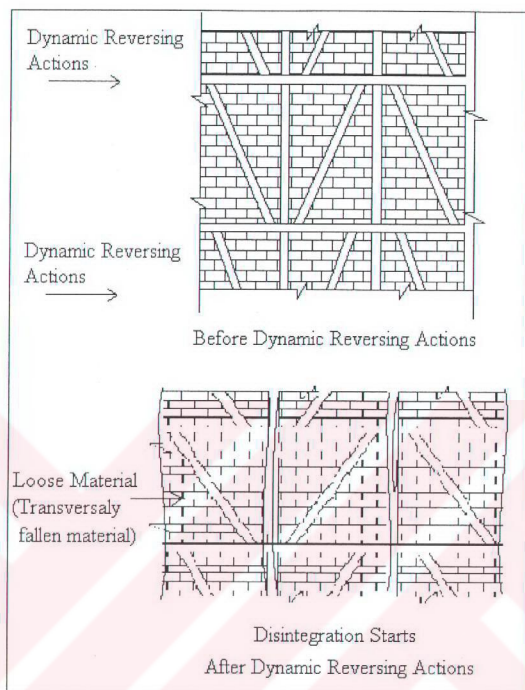

Figure 5.22 Deformation in Himiş Structure

Table 5.1 Summary of the Structural Analysis

Building Type	Total Weight $\sum W$ (kN)	Total Horizontal Force $\sum H$ (kN)	Max Displacement Under Lateral Loads Δ_{max} (mm)
Himış	2665 kN	1066 kN	5.25 mm
Bağdadi	810 kN	324 kN	2.67 mm
Bağdadi With Infill	1240 kN	496 kN	2.47 mm

CHAPTER VI

CONCLUSIONS

This thesis has two objectives. The primary objective is to indicate characteristics of traditional timber structures in Turkey. The secondary objective is to demonstrate the observations on the seismic behaviours of traditional timber framed structures. The work presented can be considered as a research contribution in the field of seismic behaviour of timber structures. The background of the topic has been discussed and the need for investigation dynamic behaviour of traditional timber frames has been demonstrated. Then the topic has been addressed from several perspectives, by using SAP2000 to determine the lateral actions of timber structures created by the seismic effect and the results of the field trips. The study has yielded some results and conclusions on parameters that influence the earthquake resistance of traditional timber frames. These results will be useful in improving the understanding of the fundamentals of the seismic response of traditional timber frames.

Results of the study can be summarized as follows:

- Timber requires periodical maintenance against insect attack as well as climatic conditions. The decay of timber is delayed with mud plastering of the surfaces in the traditional structures.
- Traditional timber construction techniques have many advantages in earthquake safe design. During an earthquake timber structures will be

subjected to less inertial forces because of their light construction compared to reinforced concrete.

- Regardless of general misgivings about the use of concentrically timber framed structures in earthquake zone, it has been shown that timber framed structures can be used as efficient lateral load resistance systems for earthquake loads in buildings.
- Energy dissipation capacity and overall ductility that are the two most important parameters for adequate seismic behaviour are high enough in the properly constructed traditional timber structures in Turkey to resist earthquakes.

This study has shown that during a seismic event, bağdadi and hımış structures do not experience the same deformation levels and also they have different moment and axial force values. However, structural configurations are quite different from each other. Thus, hımış structure is heavier than bağdadi structure because of its construction system and infill material as mentioned before. As a result of this, a comparison between distributions of internal forces under lateral loads cannot be made.

Moreover, in traditional structures with properly constructed bağdadi type structures that have infill in their exterior walls have performed better than hımış type structures. Because infill material of bağdadi type structures has a smaller modules of elasticity than hımış type structures and also infill materials are not used in interior walls so these structures are lighter than hımış type structures. Another cause of this good performance of bağdadi type structures is nails that help energy distribution.

This study has also demonstrated that the diagonal members are the most important elements of the timber-framed structures. To provide the overall ductility of the system and energy absorption capacity, the braces should be properly constructed. The lack of these elements in the frame parallel to the main earthquake direction causes partial or total collapse of the structure.

During the study, it is observed that in spite of the good performance of traditional timber structures in Düzce and Kocaeli Earthquakes, techniques used in these structures have already been lost in Turkey. However, there are several characteristics of these structures some of which can be a key for new earthquake resisting structures. In an earthquake only one thing is important that is the strength and ductility of structure. Therefore, for designing a structure in earthquake zone architects should be aware of the dynamics of seismic behaviour. According to researchers, earthquakes have shaped the traditional timber structures in the past. Therefore, people can learn many things from the traditional construction techniques. Traditional architecture should be evaluated through further researches.

In conclusion, during this study some information has been gathered on the seismic behaviour of traditional timber frames. The results, however, have also shown the need for further research to investigate a number of different topics pertaining to traditional constructions. This thesis hopes to be an initial step of these topics.

REFERENCES

Afet Bölgelerinde Yapılacak Yapılar Hakkında Yönetmelik (Building Regulations for Disaster Areas), TC Bayındırlık ve İskan Bakanlığı, Ankara, 1998.

AKYEL, R., Gölyakada Deprem (17 Ağustos ve 11 Kasım Depremleri), Gölyaka Kaymakamlığı, 2000.

ANADOL, K., ARIOGLU, E., The Structural Performance of Rural Dwellings During Recent Destructive Earthquakes in Turkey (1969-1972), 5th World Conference on Earthquake Engineering, Rome, 1973.

ANDERSON, J.G, SUCUOĞLU, H., ERBERİK, A., YILMAZ, T., İNAN, E., DURUKAL, E., ERDİK, M., ANOOSHEHPOOR, R., BRUNE, Strong Ground Motions from the Kocaeli and Düzce, Turkey, Earthquakes, and Possible Implications for Seismic Hazard Analysis, Earthquake Spectra, J.N. & Ni, S.D., 2000.

BARBIERI, M., LICHTENEGGER, J., CALABRESI, G., The İzmit Earthquake: A Quick Post-Seismic Analysis with Satellite Observations, ESA Director of Application Programmes, Earth Observation Applications Department ESA-ESRIN, Via Galileo Galilei, Italy, 2000.

BAYÜLKE, N., Depremler ve Depreme Dayanıklı Yapılar, İmar ve İskan Bakanlığı Deprem Araştırma Enstitüsü Başkanlığı, 1934.

BEDEL, B., Sustainable Urban Design in Earthquake Prone Areas: Gölyaka as a Case, Unpublished M. S. Thesis, METU, 2002.

ÇAKIR, S., Geleneksel Karadeniz Ahşap Konut Yapım Yönteminin Çağdaş Teknoloji Açısından Değerlendirilmesi, Unpublished Ph. D. Thesis, Mimar Sinan Üniversitesi, İstanbul, 2000.

ÇOBANCAOĞLU, T., Türkiye de Ahşap Evin Bölgelere Göre Yapısal Olarak İncelenmesi ve Restorasyonlarında Yöntem Önerileri, Ph.D. Thesis, Mimar Sinan Üniversitesi, İstanbul, 1998.

ÇOBANCAOĞLU, T., Hımsı Construction System In Traditional Turkish Wooden Houses Historical Constructions, P.B. Lourenço, P. Roca (Eds.), Guimarães, 2001.

DOWRICK, D. J., Earthquake Resistant Structures, John Wiley and Sons, New York, 1987.

ELDEM, S. H., Türk Evi III, Güzel Sanatlar Matbaası A. Ş., İstanbul, 1966.

ELDEM, S. H., Yapı, Devlet Güzel Sanatlar Akademisi Yüksek Mimarlık Bölümü, İstanbul, 1966.

ERDİK, M., Report On 1999 Kocaeli And Düzce (Turkey) Earthquakes, Boğaziçi University, Dept. of Earthquake Engineering, İSTANBUL, 1999.

ERİÇ, M., Yapı Malzemeleri, Cilt 2, 1978

ERMAN, E., Deprem Bilgisi ve Deprem Güvenli Mimari Tasarım, Odtü Mimarlık Fakültesi Basım İşliğı, Ankara, 2002.

GAKKAI, N. K., Design Essentials in Earthquake Resistant Buildings, Elsevier Publishing Company, New York, 1970.

GÜLHAN, D., GÜNEY, İ. Ö., The Behaviour of Traditional Building Systems Against Earthquake and its Comparison to Reinforced Concrete Frame Systems Experiences of Marmara Earthquake Damage Assesment Studies in Kocaeli and Sakarya, Deprem Güvenliği: "Geleneksel Yapılardan Alınacak Dersler" Kongresi, İstanbul, 2000.

GÜNAY, R., Geleneksel Safranbolu Evleri ve Oluşumu, Pan Matbaacılık, Ankara, 1998.

GÜNGÖR, İ. H., Ahşap Yapı Bilgisi, I. Cilt, YTÜ Teknik Okulu Yayını, 1969.

KAFESÇİOĞLU, R., Kuzey Batı Anadolu da Ahşap Ev Yapıları, Pulhan Matbaası, 1955.

KARAESMEN, E., A Study of the 28th March 1970 Earthquake in Gediz (Turkey) with Emphasis on the Behaviour of the Reinforced Concrete and Masonry Structures, Disaster Assistance Earthquake Hazard Reduction, N.9, Vol.1, 1970.

KARAESMEN, E., ...Öncesiyle Deprem Sonrasıyla..., Atılım Üniversitesi Yayını, 2002.

KARAESMEN, E., 2002 Türkiye Penceresinden Deprem Olayı, Türkiye Müteahhitler Birliği, Ankara 2002.

KILAR, O.E., Güvenli Yapı Üretiminde Alternatif Konut Yapım Sistemleri, MS Thesis, İstanbul Teknik Üniversitesi Mimarlık Fakültesi, İstanbul. 2001.

KOMISYON, II-Coğrafya Dünden Bugüne Bütün Yönleriyle Gölyaka, Selahattin Avcı Matbaası, İstanbul, 1999.

KÖYSÜREN, S., Geleneksel ve Çağdaş Ahşap Ev Çatki Sistemleri: Karşılaştırmalı Analiz, Unpublished Master Thesis, METU, Ankara, 2002.

LANGENBACH, R., Architectural Issues In The Seismic Rehabilitation Of Masonry Buildings, Management of Natural Disaster Mitigation and Response Programs for Historic Sites, 1997.

LANGENBACH, R., The Intuition from the Past: What Can We Learn from Traditional Construction, Deprem Güvenliđi: "Geleneksel Yapılardan Alınacak Dersler" Kongresi, İstanbul, 2000.

LANGENBACH, R., Survivors Amongst The Rubble: Traditional Timber-laced Masonry Buildings that Survived the Great 1999 Earthquakes in Turkey and the 2001 Earthquake in India, While Modern Buildings Fell, 2002.

NAKAGAWA, T., OHTA, M., Collapsing Process Simulations Of Timber Structures Under Dynamic Loading I: Simplification And Quantification Of The Calculating Method, The Japan Wood Research Society, 2003.

NAKAGAWA, T., OHTA, M., Collapsing Process Simulations Of Timber Structures Under Dynamic Loading II: Simplification And Quantification Of The Calculating Method, The Japan Wood Research Society, 2003.

ÖZMEN, C., Commonly Encountered Seismic Design Faults in Reinforced Concrete Residential Architecture in Turkey, MS Thesis, Middle East Technical University, Department of Architecture, May 2002.

SUCUOĞLU, H., The 1999 Kocaeli and Düzce-Turkey Earthquakes, Middle East Technical University, Ankara, Turkey.

ŞAHİN, N., A Study On Conservation and Rehabilitation Problems of Historic Timber Houses in Ankara, Unpublished PhD Thesis, METU, Ankara, 1995.

TARABIA, A.M., Response of Light- Frame Buildings Due To Earthquake Loadings, Ph.D. Thesis, Washington State University, 1994.

TOBRINER, S., Wooden Architecture and Earthquakes in Turkey: A Reconnaissance Report and Commentary on the Performance of Wooden Structures in the Turkish Earthquakes of 17 August and 12 November 1999, Deprem Güvenliği: "Geleneksel Yapılardan Alınacak Dersler" Kongresi, İstanbul, 2000.

TOKER, S., Development Of Arch Form; Exploring The Behaviour Of Masonry Arches And Arch Bridges By Finite Element Analysis, MS Thesis, Middle East Technical University, Department of Architecture, Ankara, 2000.

TUNA, M. E., Depreme Dayanıklı Yapı Tasarımı, Ankara: Tuna Eğitim ve Kültür Vakfı Pub., November 2000.

TÜBİTAK-MTA-AÜ, 17 Ağustos 1999 Depremi Sonrası Düzce Bolu İlçesi Alternatif Yerleşim Alanlarının Jeolojik İncelenmesi, Tübitak, Ankara, 1999.

YARAR, R., Türkiye'nin Kırsal Bölgelerinde, Yöresel Doğal Verilerin, Sosyo Ekonomik Özellikleri ve Olanakları Açısından, Ekonomik ve Depreme Dayanıklı Kırsal Yapı Karakteristiklerinin Saptanması ve Geliştirilmesi, Tübitak Matbaası, Ankara, 1978.

Web Sites

<http://people.cornell.edu/pages/jo24/cuhk/courseNotes/timber/timber.html>

(Accessed: May 2003)

http://www.timberbestpractice.org.uk/tbpp/ATR/PRODUCTS/f_struc7.htm

(Accessed: June 2003)

<http://www.sivas.gov.tr/tarihisivasevleri/k14.htm>

(Accessed: June 2003)

<http://www.primeindia.com/manav/hazard4.html>

(Accessed: August 2003)

http://www.glaciermedicaled.com/Earthquake_html/EQ_world/turkey2.jpg

(Accessed: August 2003)

<http://www.indianpurchase.com/magonline/construction>

(Accessed: September 2003)

http://www.umcor-ngo.org/english/countries/turkey_1.htm

(Accessed: November 2003)

<http://www.koeri.boun.edu.tr/deprenmmuh/>

(Accessed: January 2004)

http://www.eas.slu.edu/Earthquake_Center/TURKEY/

(Accessed: March 2004)

<http://www.icomos.org/iiwc/seismic-i.html.en>

(Accessed: March 2004)

<http://cires.colorado.edu/~bilham/Duzce.html>

(Accessed: March 2004)

APPENDICES

APPENDIX A

MAJOR EARTHQUAKES OF 20TH CENTURY

Table A.1 Major earthquakes of 20th century

YEAR	PLACE OF OCCURENCE	MAGNITUDE (Richter Scale)	DEATHS
1905	Kangra Valley, India	8.6	20,000
1907	Afganistan	8.1	12,000
1908	Messina, Italy	7.5	2,00,000
1915	Avenzzano, Italy	7.5	30,000
1918	South-East China	7.3	10,000
1920	Kansu, China	8.5	1,80,000
1923	Tokyo-Yakohama	8.3	1,63,000
1927	Nansham, China	8.0-8.3	1,80,000
1933	North-Central China	7.4	10,000
1934	Bihar, India	8.4	10,700
1935	Quetta, Pakistan	7.5-7.6	60,000
1939	Chillan, Chile	8.3	40,000
1939	Erzincan, Turkey	8.0	40,000

Table A.1 Major earthquakes of 20th century(Continued)

<http://www.primeindia.com/manav/hazard4.html>

1948	Taiwan	7.3	19,800
1962	Buyin-zara, Iran	7.3	14,000
1968	Dasht-e-Bayaz, Iran	7.3-7.8	18,600
1970	Chimbote, Peru	7.8-7.9	67,000
1974	Wesr-Central China	6.8	20,000
1975	Haicheng, China	7.3-7.4	10,000
1976	Tang-shan, China	7.8-8.1	7,50,000
1978	Tabas, Iran	7.7	25,000
1988	Darbhang& Nepal	6.5	850
1990	Northern Iran	7.3	50,000
1990	Iran	7.3	40,000
1995	Kobe, Japan	7.2	5,500
1997	Iran	7.1	2,500
1998	Afganistan	6.9	5,000
1999	Turkey	7.4	40,000(?) 20,000 (Corrected results)

Table A.2 Major Earthquakes in Turkey between 1509 and 2002
(Karaesmen, 2002:3)

YEAR	PLACE OF OCCURENCE	MAGNITUDE (Richter Scale)
1509	İstanbul	6.8
1719	İstanbul, İzmit, İznik	6.5
1766	İstanbul	6.8
1894	İstanbul, Adapazarı, Marmara	7.0
1939	Erzincan	7.9
1953	Yenice, Gönen	7.4
1957	Fethiye	7.1
1966	Varto	6.9
1970	Gediz	7.2
1975	Lice	6.9
1976	Çaldıran, Muradiye	7.2
1992	Erzincan	6.8
1995	Dinar	6.3
1998	Ceyhan, Adana	5.9
1999	Marmara	7.4
1999	Düzce, Kaynaşlı	7.2
2002	Sultandağı, Çay	6.3

APPENDIX B

Seismicity of Turkey

Numerous big scale earthquakes have happened in Turkey throughout the history. The earliest earthquake records date back to 411 B.C. There have been nearly 100 earthquakes with magnitudes 7.0 or greater in Turkey.

Özmen (2002) points out that Turkey is located on the Alp-Himalayan Seismic Belt, which starts from the Azores in the Atlantic Ocean and stretches away into the Southeast Asia. The seismic activity is very complex around the East Mediterranean region. Most of the country is on the Anatolian plate, which is located in the middle of the Eurasian, African and Arabic Plates. The African and Arabic plates travel north and force the Anatolian plate to move west. The majority of the destructive earthquakes take place on the borders of the Anatolian Plate. Seismic Plates Around Turkey and seismic faults in Turkey are indicated in Figure B.1.

There are three main sources of seismic activity in Turkey, which are,

North Anatolian Fault (NAF): Several shorter fault lines and stretches constitute this fault. It has a well-developed surface expression for most of its length of 1300 km. North Anatolian Fault system is one of the most seismically active right-lateral strikeslip faults in the world. Since 1939 there have been 9 M 7.0 or larger earthquakes along the fault. The most recent earthquakes on this fault are the 1999 Kocaeli and Düzce Earthquakes.

(www.usc.edu/dept/civil_eng/structural_lab/eqrp/seismicity.html).

East Anatolian Fault (EAF): The East Anatolian Fault is an active left-lateral strike slip fault, which extends from Antakya to Karlıova. It is a fault zone, which is about 2-3 km wide, and links into the Dead Sea Fault System.

(www.usc.edu/dept/civil_eng/structural_lab/eqrp/seismicity.html).

Western Turkey Graben Complex: This is an area of intense seismic activity, which is related to the east-west trending graben complexes in the Aegean region.

(www.usc.edu/dept/civil_eng/structural_lab/eq-rp/seismicity.html).



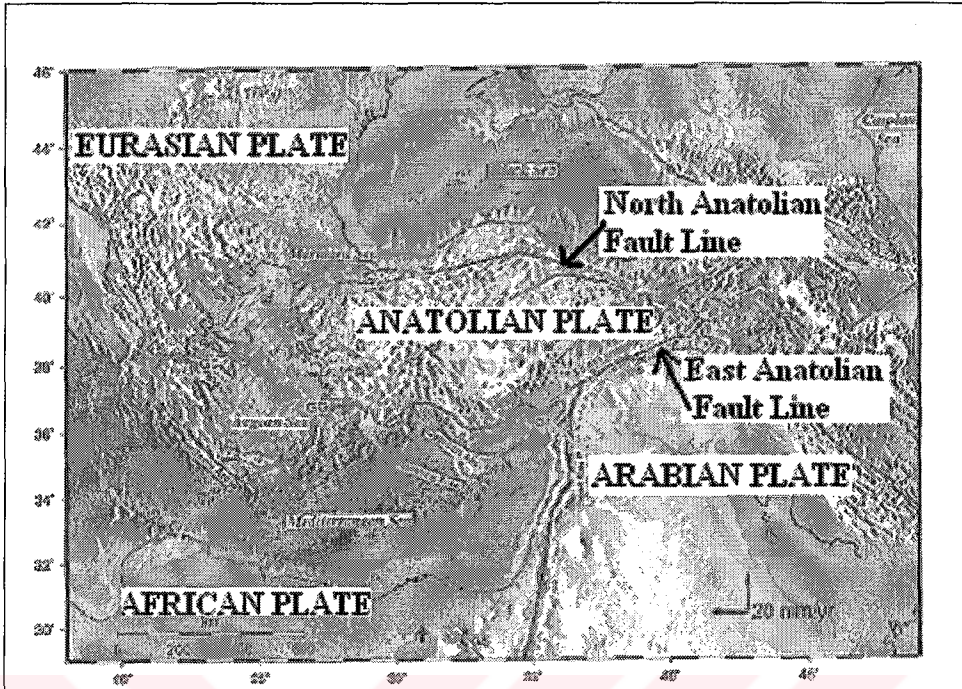

Seismic Plates Around Turkey
 (Barbieri, Lichtenegger & G. Calabresi, 2004)

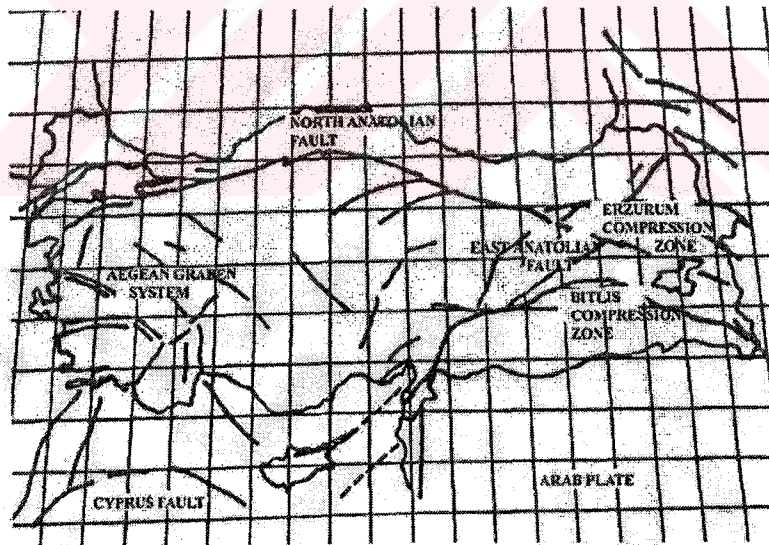

Seismic Faults In Turkey (Özmen, 2002)

Figure B.1 Seismic Plates Around Turkey and Seismic Faults In Turkey