

DESIGN OF SMALL DUAL BAND SLOT ANTENNA

A MASTER'S THESIS

IN

M.S., ELECTRICAL ELECTRONICS ENGINEERING DEPARTMENT

ATILIM UNIVERSITY

By

Mabroka Bupraig

January 2017

DESIGN OF SMALL DUAL BAND SLOT ANTENNA

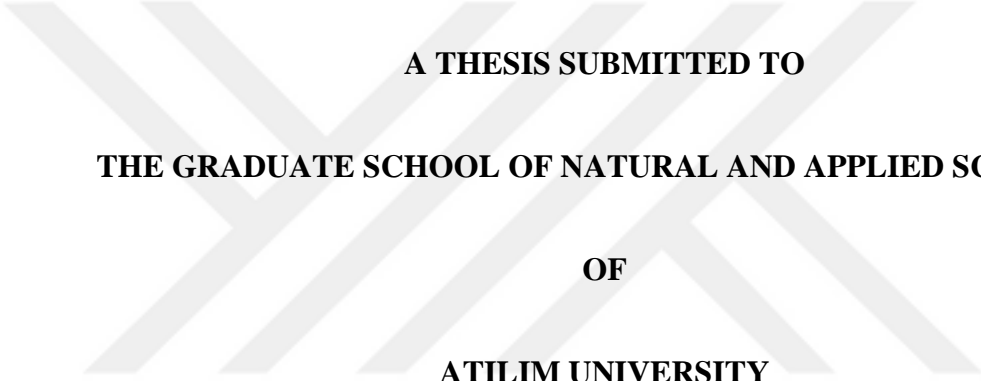

**A THESIS SUBMITTED TO
THE GRADUATE SCHOOL OF NATURAL AND APPLIED SCIENCES
OF
ATILIM UNIVERSITY**

BY

MABROKA BUBRAIG

IN PARTIAL FULFILMENT OF THE REQUIREMENTS FOR THE DEGREE

OF

MASTER OF SCIENCE

IN

THE DEPARTMENT OF ELECTRICAL ELECTRONICS ENGINEERING

January 2017

Approval of the Graduate School of Natural and Applied Sciences, Atılım University.

Prof. Dr. K. Ibrahim Akman

Director

I certify that this thesis satisfies all the requirements as a thesis for the degree of Master of Science.

Asst. Prof. Dr. Kemal Efe Eseller

Head of Department

This is to certify that we have read the thesis “Design Of Small Dual Band Slot Antenna” submitted by “mabroka bubaig” and that in our opinion it is fully adequate, in scope and quality, as a thesis for the degree of Master of Science.

Prof. Dr. Ali Kara

co-supervisor

Prof. Dr. Elif Aydin

Supervisor

Examining Committee Members

Asst. Prof. Dr. Kemal Efe Eseller

Prof. Dr. Ali Kara

Assoc. Prof. Dr. Nursel Akcam

Assist. Prof. Dr. Hakan Tora

Prof. Dr. Elif Aydin

Date: 26.01.2017

DECLARATION

I declare and guarantee that all data, knowledge and information in this document have been obtained, processed and presented in accordance with academic rules and ethical conduct. Based on these rules and conduct, I have fully cited and referenced all material and results that are not original to this work.

MABROKA BUBRAIG

ABSTRACT

Design of small dual band slot antenna

Mabroka Bupraig

M.S., Electrical Electronics Engineering
Department

Supervisor: Assoc. Prof. Dr. Elif AYDIN

Co-Supervisor: Prof. Dr. Ali KARA

January 2017, 42 pages

In telecommunication, a micro-strip antenna (i.e., a printed antenna) usually means an antenna fabricated utilizing microstrip methods on a printed circuit board (PCB), with a continuous metal layer attached to the inverse side of the substrate which forms a ground plane. They are for the most part utilized at microwave frequencies. Microstrip antennas have turned out to be extremely mainstream in recent decades due to their thin planar profile which can be incorporated into the surfaces of customer items, aircraft, and missiles; their simplicity of fabrication using printed circuit techniques; the simplicity of integrating the antenna on the same board with the rest of the circuit, and the possibility of adding active devices such as microwave integrated circuits to the antenna itself to make active antennas. Antennas cover a wide range of applications in different areas, such as mobile communication, satellite navigation, internet services, automobiles, and radars. In this thesis, we simulated and fabricated small dual band slot antenna with a small size and good outcomes. The design parameters of the antenna used the transmission line model, and HFSS electromagnetic software was used for the simulation process.

Keywords: Antenna, Microstrip antenna, slotted antenna, dual band antenna, small antenna.



ÖZ

Çift Bantlı Küçük Yarık Anten Tasarımı

Mabroka Bupraig

Yüksek Lisans,

Elektrik Elektronik Mühendisliği Bölümü

Tez Yöneticisi: Prof. Dr. Elif AYDIN

Ocak 2017, 42 sayfa

Haberleşmede, genellikle mikroşerit anten, bir antenin metal tabakaya eklenmiş alt malzemenin arka tarafı toprak düzlemi olan baskı devre üzerine mikroşerit yöntemler kullanarak üretilmesi demektir. Mikroşerit antenlerin büyük bir kısmı mikrodalga frekanslarında kullanılmaktadır. Mikroşerit antenler, uçak, füze ve ticari ürünlerin yüzeyleriyle birleştirilebilen ince düzlemsel profillerinden, baskı devre teknikleri kullanarak üretilmesinin basitliği, devrenin diğer elemanlarıyla aynı devre kartına basılması ve mikrodalga tümlşik devreler gibi aktif elemanlar eklenerek aktif antenler elde etme imkanından dolayı son yıllarda ilgi oldukça çok artmıştır. Antenler, mobil haberleşme, uydu, internet servisi, taşıt ve radarlar gibi farklı alanlarda çok geniş uygulama alanını kapsar. Bu tezde, küçük boyutlu ve iyi sonuçlar veren çift bantlı küçük yarık anten benzetimi yapıldı ve üretildi. Antenin tasarım parametreleri için iletim hattı modeli ve benzetim için de HFSS elektromagnetik yazılım program kullanıldı.

Anahtar Kelimeler: Anten, mikroşerit anten, yarık anten, çift bantlı anten, küçük anten

DEDICATION

To my parents, and all of my family, without whom none of my success would be possible



ACKNOWLEDGMENTS

I wish to express sincere gratitude to my supervisor Prof. Dr. Elif AYDIN and co-supervisor Prof. Dr. Ali Kara whose invaluable guidance and support have added a great deal to the substance of this thesis. I must also thank my country that undertook my education. Besides professors, my friends here in Turkey have also given me crucial assistance and fruitful suggestions in my research and academic coursework. I would like to thank them as well for the relaxing discussions I have had with them.

Last but not least, a very big thank you to my beloved family and my parents for their support, love and constant encouragement they have bestowed upon me. Without their support, I would never have gotten so far.

A big thank for Allah who gave me all this success.

CONTENTS

ABSTRACT	i
ÖZ	ii
DEDICATION	iii
ACKNOWLEDGMENTS	iv
CONTENTS	v
LIST OF TABLES	ix
LIST OF FIGURES	vii
CHAPTER 1	1
INTRODUCTION	1
CHAPTER 2	3
MICROSTRIP ANTENNAS	3
2.1 INTRODUCTION	3
2.2 CONSTRUCTION AND GEOMETRY	4
2.3.MICROSTRIP ANTENNA TYPES	5
2.4.MICROSTRIP FEED	6
2.5. RECTANGULAR PATCH	8
2.5.1. Transmission Line Model	8
2.5.2 Width	11
2.5.3 Length	11
2.5.4 Ground Plane	12
2.6 BANDWIDTH	13
2.7 RADIATION PATTERN	13

2.8 GAIN.....	15
2.9 DIRECTIVITY	16
2.10 RETURN LOSS	16
2.11 VOLTAGE STANDING WAVE RATIO	16
2.12 SMALL ANTENNA.....	17
2.13 MINIATURIZED TECHNIQUE OF PATCH ANTENNA	17
CHAPTER 3	19
ANTENNA DESIGN AND SIMULATION	19
3.1 DESIGN OF SMALL DUAL SLOT ANTENNA	19
3.1.1 Introduction	19
3.2 ANTENNA DESIGN.....	20
3.3 SIMULATION.....	22
3.4 RESULT AND DISCUSSION	24
3.4.1 Return Loss	24
3.5. DISCUSSION	31
CHAPTER 4	32
ANTENNA FABRICATION AND MEASUREMENT	32
4.1 INTRODUCTION	32
4.2 SMALL DUAL BAND SLOT ANTENNA	32
4.3 Measurement of Gain.....	35
CHAPTER FIVE.....	38
CONCLUSION.....	38
REFERENCES.....	40



LIST OF TABLES

TABLE

Table 3-1. The dimension of proposed antenna by mm.....	23
Table 3-2. The difference between two height of substrate.....	25
Table 3-3. Effect of l11 on resonant frequency and return loss	30
Table 4-1. Comparison between simulated results and fabricated results	34
Table 4-2. Compare between simulated gain and measured gain.....	37

LIST OF FIGURES

FIGURE

Figure 2-1. Microstrip antenna and coordinate system	5
Figure 2-2. Representative shapes of microstrip patch element.	6
Figure 2-3. Typical feed for microstrip antenna	7
Figure 2-4. Microstrip line and its electric field lines, and effective dielectric constant geometry.....	8
Figure 2-5. Field configuration (modes) for rectangular microstrippatch	10
Figure 2-6. The electric field lines on both edges of the microstrip antenna.....	11
Figure 3-1. Structure of the antenna.....	21
Figure 3-2. The proposed Antenna by HFSS	22
Figure 3-3. The return loss at 0.8mm of height.....	24
Figure 3-4. The return loss at 1.6mm of height.....	25
Figure 3-5. The gain of the proposed antenna at 0.8mm of height	26
Figure 3-6. The gain of the proposed antenna at 1.6mm of height.	27
Figure 3-7. Gain vs frequency at 1.6mm of height	27
Figure 3-8. VSWR of proposed antenna at 0.8mm of height.....	28
Figure 3-9. VSWR of proposed antenna at height 1.6mm.....	28
Figure 3-10. The effect of length slot 22 at 3.5 GHz	29
Figure 3-11. The effect of length slot 11 at 5.5GHz.	30
Figure 4-1. Top and bottom side of antenna fabrication.....	33
Figure 4-2. Return loss measurement.....	34
Figure 4-3. Block diagram of gain measurement system.....	37



CHAPTER 1

INTRODUCTION

Wireless technology has advanced rapidly and taken an increasing share in the lives of individuals all over the world. Increasingly large amount of people depend directly or implicitly on innovation.

Wireless is a term used to portray media communications in which electromagnetic waves convey the flag over part or the majority of the correspondence way.

In the mid-twentieth century, radiotelegraphy was used to provide real-time wireless transmissions. Later, as balance made it possible to transmit voice and music via remote control, it was named way radio.

Utilizing of small size antenna has rapidly increased because of the fast advancement in wireless communication technology. Microstrip patch antennas are very useful in modern wireless communications systems.

Miniaturization of antennas in recent years is becoming increasingly important due to the demand for small antennas especially for mobile communication. Integrated antennas should return to the production of small serial terminals. Lightweight and low cost are other important specifications. A lot of formation quotations are proposed in the literature. Many of these are commonly known geometries that leads to reducing the physical size of the antenna [1] - [2]. In other words, the strategy increases the effective dielectric constant through the use of high permittivity substrates [3]. Another technique is slot to reduce the size of a patch [4]. Else possibility is to load the antenna either with resistive or capacitive loads or even with shorting pins [5] - [6]. Recently, compact

antennas integrated active devices have been proposed as in [7], [8]. But so far, all structures are known as based on intuitive design and radiation mechanisms that can be expected to behave.

The aim of this thesis was to design a small dual band microstrip patch antenna to operate in two frequency, at 3.1GHz and 5.6GHz. The proposed antenna was designed as L-shape slots with quarter wavelength matching technique. Antenna simulation was done by HFSS software. Due to then obstacles, the antenna was fabricated.

This thesis includes five chapters, starting from basic information about wireless technology Chapter One. Chapter Two covers microstrip patch antenna structure, design and properties. Simulation of the proposed antenna is introduced in Chapter Three. Chapter Four deals with the fabricated antenna and compares its results with the simulated one from the previous chapter. Chapter Five discusses how the thesis resulted in such a design in practice and deals with simulation results.

CHAPTER 2

MICROSTRIP ANTENNAS

2.1 INTRODUCTION

In the mid-1970s, antennas changed with more enthusiasm than before. Although this was the case, it seemed in the 1950s that antennas were used on a large scale commercially and for government applications. Changer correction of patch antennas is generally Thunder in style rather than traveling wave, and it is described as very fruitful with a moderate operational capacity for data transfer.

There are advantages and disadvantages to everything and those of the antennas changer are as follows:

Advantages:

- Size and profile: in microstrip antenna, the volume is smaller than other radiators, for single layer use substrates thickness less than $0.05\lambda_0$ (where λ_0 is the free space wavelength) and for multi-layer no more than $1\lambda_0$.
- Ease of manufacturing, integration and low cost
- Ease of forming array.
- Efficiency.

Disadvantages:

- Impedance bandwidth: the impedance bandwidth of a microstrip antenna is narrow for two factors including resonant style antenna and thin thickness.

- Excitation of surface waves: For the presence dielectric substrate, the microstrip antenna always excites a TM_0 surface wave. This can prompt decreased efficiency and coupling.
- Size: Size appears to be both advantage and a disadvantage. The microstrip antenna used in the wireless industry is too huge when compared with the hand-held communication which utilizes a frequency below 2 GHz. The microstrip antenna must have a length equivalent to half a guide wavelength at operation frequency.
- Radiation performance [9].

2.2 CONSTRUCTION AND GEOMETRY

Microstrip antenna as shown in Figure 2.1 generally utilizes thin metallic patch on dielectric substrate of height h , the metallic patch possesses a small portion of a wavelength over ground plane [2].

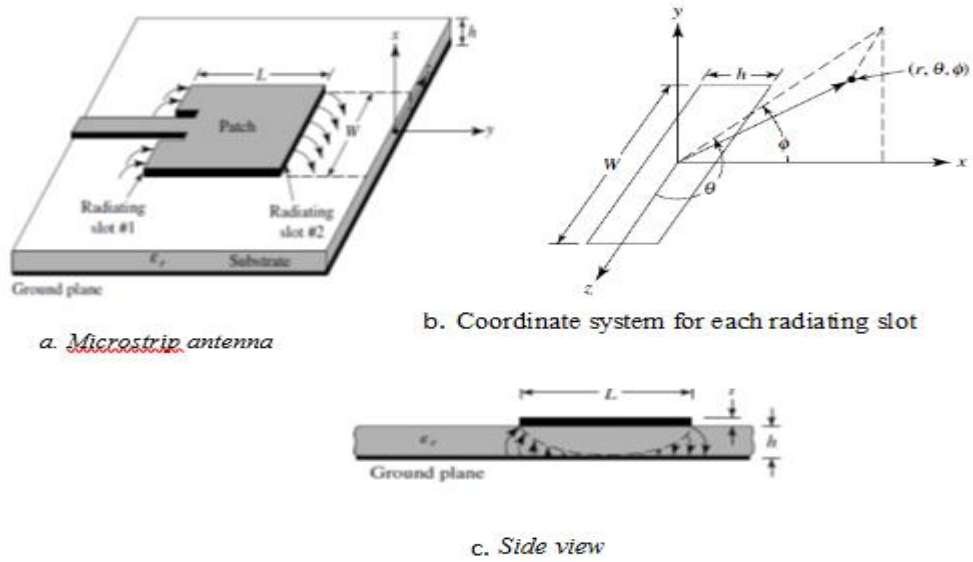

Figure 2.1. Microstrip antenna and coordinate system [10].

2.3 MICROSTRIP ANTENNA TYPES

Microstrip antenna has a wide range of shapes as shown in Figure 2.2. The most basic are rectangular, dipole, and circular shapes. Where the simplicity of analysis, manufacture, and good performance characteristics are considered, these types are broadly utilized.

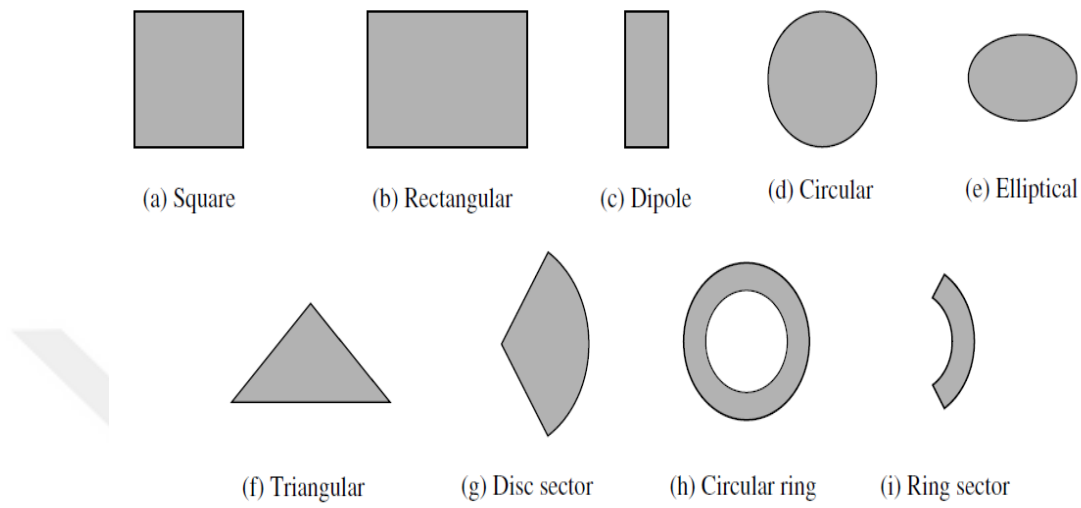
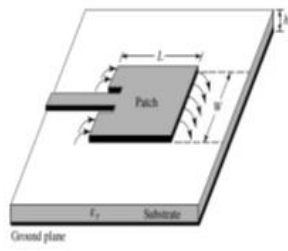

Figure 2.2. Representative shapes of microstrip patch element [10].

2.4 MICROSTRIP FEED

There are many techniques to feed microstrip antenna, including the microstrip line, coaxial probe, aperture coupling, and proximity coupling as shown in Figure 2.3.

- Microstrip line: it is easy to fabricate, simple to match but when the thickness of the substrate increases, so does the surface wave.
- Coaxial probe feed: it is likewise simple to manufacture and match, and it has narrow bandwidth, hard to model.



(a) Microstrip line feed

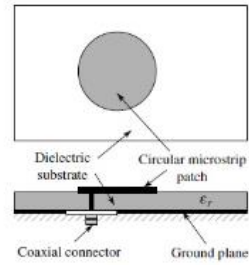

(b) Probe feed

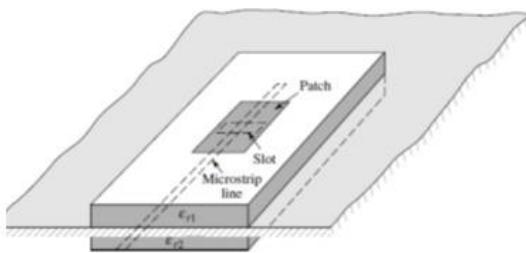

(c) Aperture coupled feed

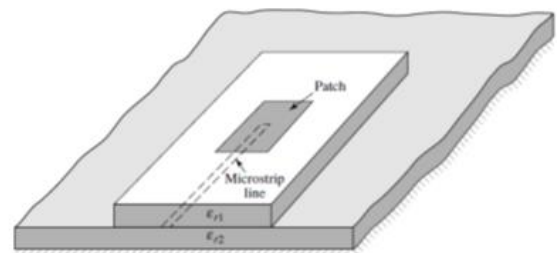

(d) Proximity-coupled feed

Figure 2.3. Typical feed for microstrip antenna [10].

2.5 RECTANGULAR PATCH

Rectangular patch is most commonly used on a large-scale design. It is very easy to analyze each of the transmission lines and form a cavity, the most accurate thin substrates. We are of the transmission line because it is less demanding to determine.

2.5.1 Transmission Line Model

A rectangular microstrip antenna can be represented as an array of two radiation narrow apertures (slots), each with a width W and height h , separated by distance L . Basically, the transmission line model represents the micro-strip antenna by two slots, separated by low impedance Z_c transmission line of length L .

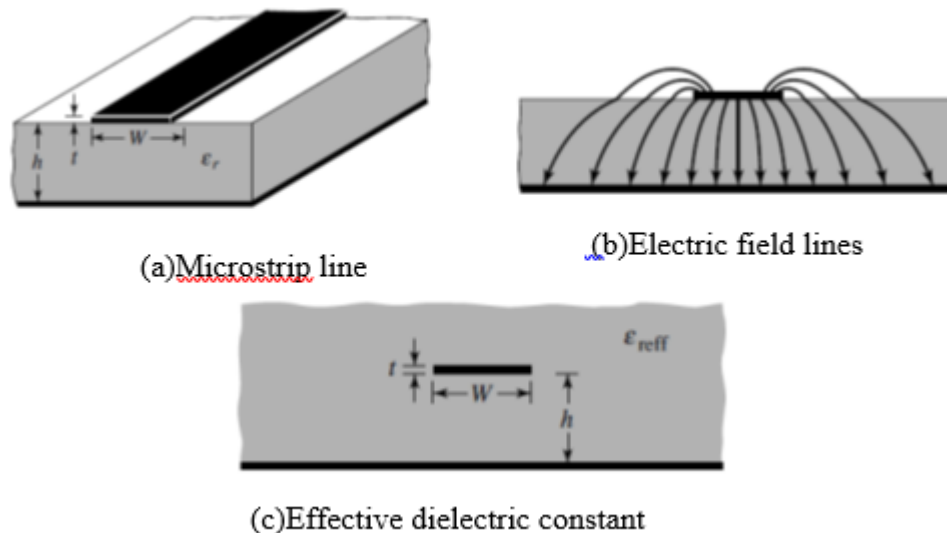

Figure 2.4. Microstrip line and its electric field lines, and effective dielectric constant geometry [10].

For any antenna, the propagation mode is TM, and to work on TM mode, the patch length must be less than $\lambda/2$ where:

$$\lambda = \frac{\lambda_0}{\epsilon_{reff}} \quad (2.1)$$

Where λ is a wavelength, ϵ_{reff} is effective dielectric constant.

In transmission line mode, the circulation of electric field lines, as seen in Figure 2.4.b, has thickness t , and therefore, the transmission line cannot bolster exchange - electric - attractive TEM, where TEM alludes to direct exchange of electric field lines to dielectric. Since some of the electric field lines go into the air before entering the dielectric substrate, this cannot be affirmed. The overwhelm mode TM a, b can be found in Figure 2.5.

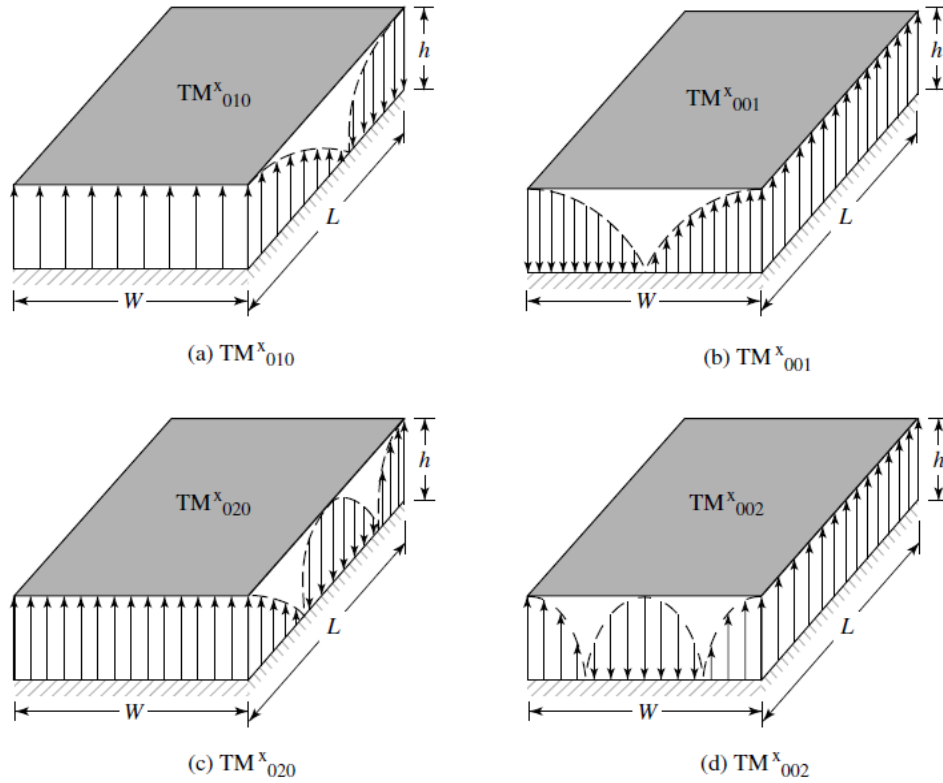

Figure 2.5. Field configuration (modes) for rectangular microstrip patch [10].

For this problem, relative permittivity ϵ_r will be replaced with ϵ_{reff} it is given as:

$$\epsilon_{reff} = \frac{\epsilon_r + 1}{2} + \frac{\epsilon_r - 1}{2} \left[1 + 12 \frac{h}{w} \right]^{-0.5}, \frac{w}{h} > 1 \quad (2.2)$$

Where h is the dielectric substrate height, ϵ_r is the substrate dielectric constant and w is the patch width.

In the design, the length of the patch will be stretched out on both sides because of the move of the electric field lines through the air as shown in Figure 2.6

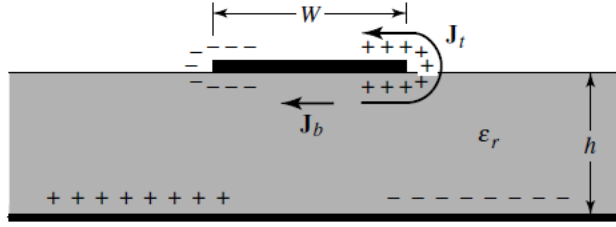

Figure 2.6. The electric field lines on both edges of the microstrip antenna [10].

ΔL is calculated by the following formula:

$$\Delta L = \frac{0.412 * h * (\epsilon_{reff} + 0.3) * (\frac{W}{h} + 0.264)}{(\epsilon_{reff} - 0.258) * (\frac{W}{h} + 0.8)} \quad (2.3)$$

Presently, we will portray the antenna width, length and ground plane.

2.5.2 Width

The following equation is used to calculate the width:

$$W = \frac{c}{2 * f_c * \sqrt{\frac{\epsilon_r + 1}{2}}} \quad (2.4)$$

Where f_c is the resonance frequency, c is the speed of light and ϵ_r is the dielectric constant of substrate.

2.5.3 Length

The effective length L_{eff} can be found from the following equation:

$$L_{\text{eff}} = \frac{c}{2 * f_c * \sqrt{\epsilon_{\text{reff}}}} \quad (2.5)$$

The actual length can be calculated by the following equation:

$$L = L_{\text{eff}} - 2 * \Delta L \quad (2.6)$$

2.5.4 Ground Plane

An infinite ground plane is utilized only as a part of transmission line model.

On the off chance that the ground plane is six times bigger than the height of the dielectric substrate, in addition to the utilized length or width, it can utilize a finite ground plane.

Presently, we can compute the ground width and length as the accompanying conditions:

$$wg = 6 * h + w \quad (2.7)$$

$$Lg = 6 * h + L \quad (2.8)$$

where wg is the ground width and Lg is the ground length.

2.6 BANDWIDTH

Bandwidth is defined as the range of frequency on either side of a center frequency "usually the resonance frequency of the dipole", where the antenna characteristics are within acceptable value at the center frequency.

For broad band antenna, the bandwidth is normally communicated as the proportion of the upper - to-lower frequency of satisfactory operation.

For narrowband antennas, the band width is expressed as a percentage of frequency difference (upper - lower) over the center frequency of the bandwidth.

$$BW_{\text{broadband}} = \frac{f_H}{f_L} \quad (2.9)$$

$$BW_{\text{narrowband}(\%)} = \left(\frac{f_H - f_L}{f_c} \right) * 100 \quad (2.10)$$

Where BW is the bandwidth, f_H is the upper frequency, f_L is the lower frequency, and f_c is the center frequency.

2.7 RADIATION PATTERN

A reception apparatus radiation example is characterized as a scientific capacity or graphical representation of the radiation properties of the antenna as a component of space directions. In most cases, we determine the radiation pattern in far field region and represent as a function of the directional coordinate. The coordinate system for antenna analysis is shown in Figure 2.7.

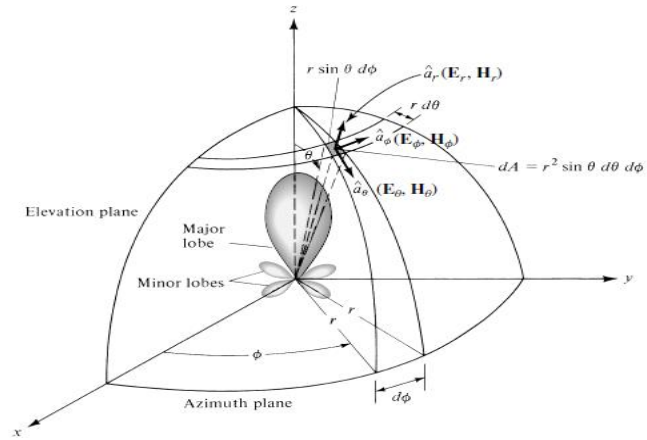

Figure 2.7. The coordinate system for antenna analysis [10].

The execution is frequently portrayed as far as its guideline E and H plane. The E plane is the electric field and the H plane is the attractive field. In Figure 2.7, E and H fields are indicated in rectangular patch.

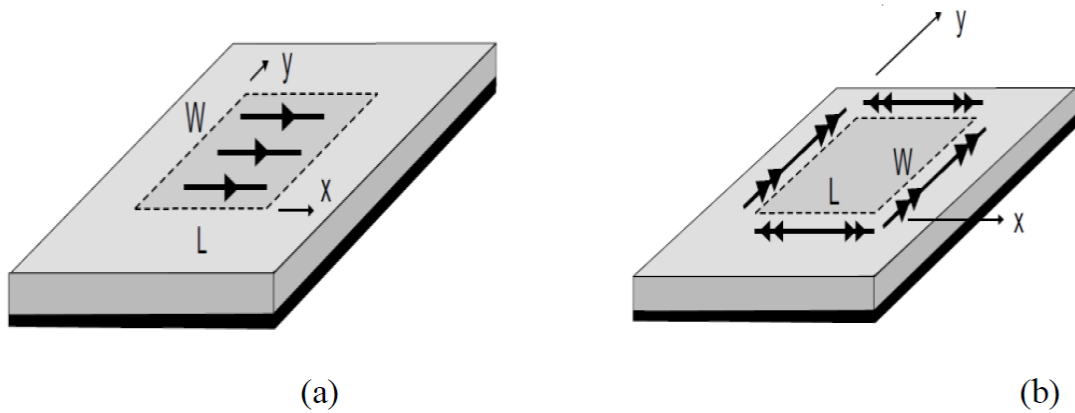

Figure 2.8. (a) The electric current for the patch, (b) The magnetic current for the patch [11].

2.7.1 RADIATION PATTERN LOBES

There are many lobes in radiation pattern that we can classify into major, minor, side, and back lobe. Next figure shows that:

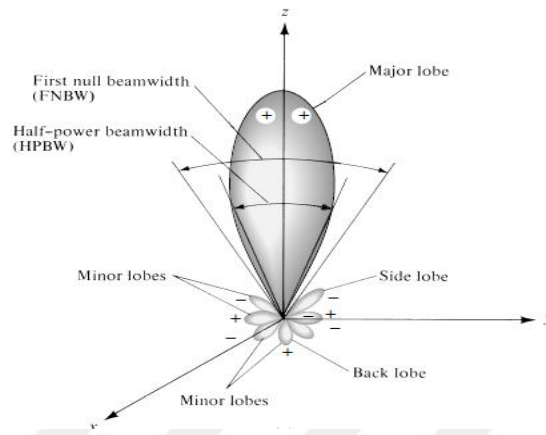

Figure 2.9. Radiation lobes and beam widths of the antenna pattern [10].

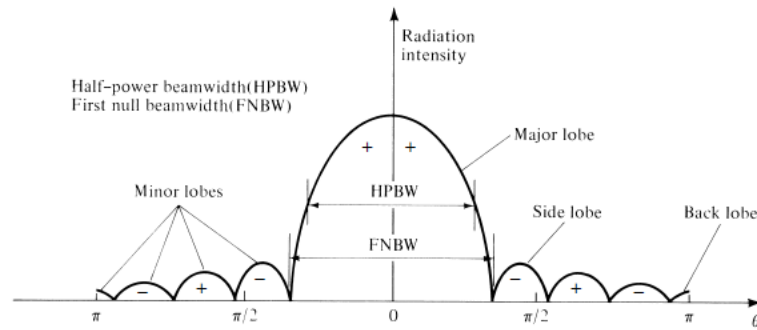

Figure 2.10. Linear plot of power pattern and its associated lobes and beam width [10].

2.8 GAIN

Gain of an antenna is characterized as the proportion of the intensity in a provided guidance, to the radiation intensity that would be acquired if the power acknowledged by the antenna were radiation isotropic. Radiation intensity is equivalent to the power input partitioned by 4π , which can be communicated in a condition shape as:

$$Gain = 4\pi \frac{\text{radiationintensity}}{\text{totalinput(accepted)power}} = 4\pi \frac{U(\theta,\varphi)}{P_{in}} \quad (2.11)$$

2.9 DIRECTIVITY

Directivity is characterized as the ratio of radiation intensity in a given direction from the antenna to the average radiation intensity in all directions. The average radiation intensity is equivalent to total power radiated by the antenna divided by 4π .

$$D = \frac{U}{U_0} = \frac{4\pi U}{P_{rad}} \quad (2.12)$$

Where U is radiation intensity (w per unit solid angle), U_0 is the radiation intensity of isotropic source (W per unit solid angle), and P_{rad} is total radiation power (W).[10]

2.10 RETURN LOSS

This can be characterized as the impression of signal power from the input of a gadget in transmission line or another conductor. Return loss is given by:

$$RL(\text{dB}) = 10 \log \frac{P_r}{P_i} \quad (2.13)$$

where P_r is the reflected power, P_i is the power supplied by the source.

2.11 VOLTAGE STANDING WAVE RATIO

Voltage standing wave ratio (VSWR) refers to the power reflected from the antenna and describes how well the impedance of the antenna matches the transmission line. Many strategies could be utilized as part of VSWR measuring, such as return loss, mismatch loss and reflection coefficient. Reflection coefficient is the basic one, which we made use of by the accompanying condition:

$$\rho = \frac{E_r}{E_i} \quad (2.14)$$

where, E_r is the reflection voltage and E_i is the incident voltage.

Now, we can calculate VSWR:

$$\text{VSWR} = \frac{1+\rho}{1-\rho} \quad (2.15)$$

2.12 SMALL ANTENNA

One of the many advantages of microstrip patch technology over its competitor is its low profile, and hence, small volume. Another key advantage of this printed antenna is the relative ease in which it can be connected to the feed network. For these reasons, antenna design engineers have found that microstrip patch antenna could be used for applications requiring very limited space to mount the antenna [10].

2.13 MINIATURIZED TECHNIQUE OF PATCH ANTENNA

In a few applications, further reduction in size and weight of the patch antenna is desirable. Distinctive strategies can be utilized as a part of this proposition, some of which can be summarized as follows:

- Substrate with high permittivity: this is the most widely recognized strategy. It comprises utilizing a substrate with a high dielectric constant consistent with lessening the

guided wavelength engendering under the patch and decrease the antenna size as a result.

- Slots strategy: In order to decrease the size of a patch, spaces can be presented in either the patch plane or the ground plane. Thus, the current in the patch and the field under the patch will go longest as a result of openings, which gives a smaller resonance frequency and smaller antenna size along these lines.
- Folding technique: this method consists of folding the patch antenna by moving from a single layer structure to a two-layer structure. The planar dimension of the antenna is then decreased. Regardless of the possibility that the patch is folded, the electric field between the patch and the ground plane will travel to every part with an undistinguishable separation from the resounding unfurled patch and resonate in the same frequency [12].

CHAPTER 3

ANTENNA DESIGN AND SIMULATION

3.1 DESIGN OF SMALL DUAL BAND SLOT ANTENNA

3.1.1 Introduction

The most commonly used microstrip antenna is a rectangular patch which looks like a truncated microstrip transmission line. It is approximately of one-half wavelength long. When air is used as a dielectric substrate, the length of the rectangular microstrip antenna is about half the free-spaced wavelength. Since an antenna is charged with a dielectric as its substrate, the antenna length decreases as the relative dielectric constant of the substrate. The resonant length of the antenna is slightly shorter due to the extended electrical "fringed areas" that increase the electrical length of the antenna slightly. An early model of the microstrip antenna is a section of a microstrip transmission line with equivalent loads at both ends to represent loss of radiation.

Dual band antennas have lots of practical uses especially for mobile devices. They operate on two bands or frequencies, like radio stations, and can work either one at a time or simultaneously, depending on the capabilities of the individual device.

3.2 ANTENNA DESIGN

The proposed antenna is printed on a 0.8 mm-thick FR4 substrate with relative permittivity 4.4. The antenna is composed of an L-shaped slot fed by a 50 ohm microstrip line and is embedded at the center of the ground plane rectangular slit which is shortened with the L-shaped slot and another rectangular slit at the bottom of the ground plane. The total dimension of antenna is $28*16*0.8 \text{ mm}^3$ and is shown in Figure 3.1. We have used the same geometry, but we changed the thickness of substrate, and we compare the result in the case of changing the thickness and then we have examined the effect of slots on frequency and return loss.

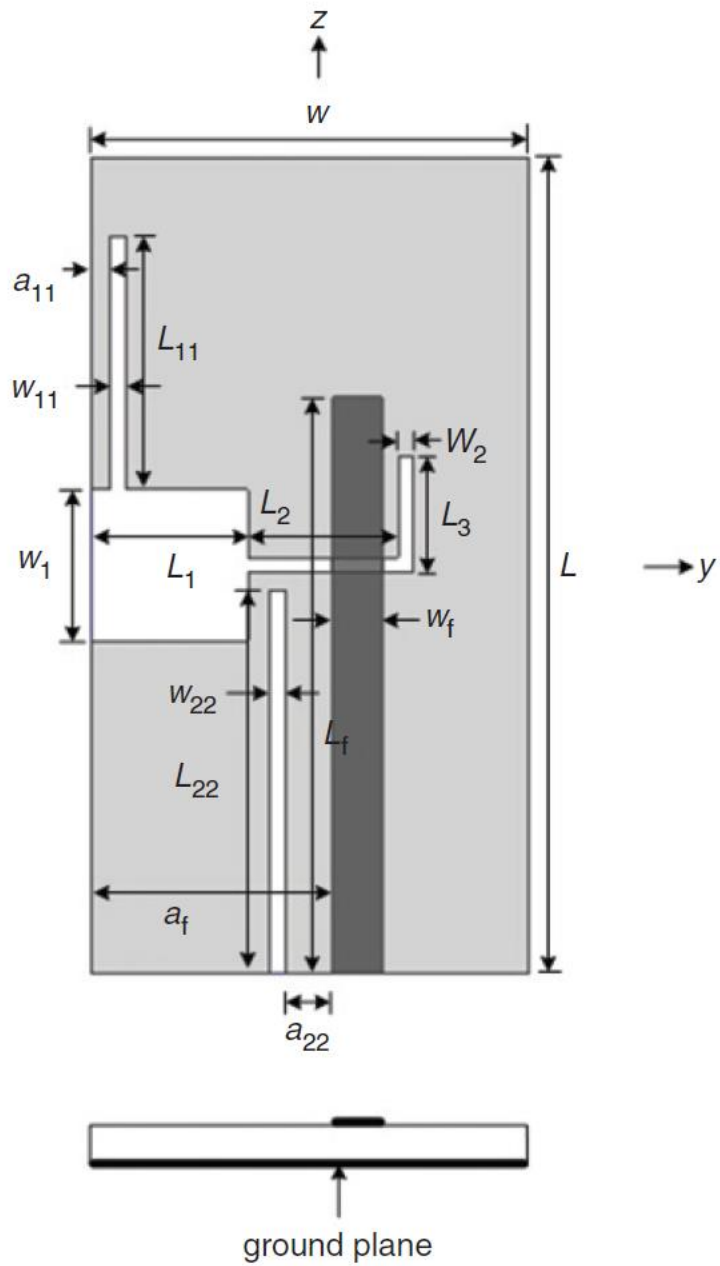

Figure 3.1. Structure of the antenna [13].

3.3 SIMULATION

There are many software programs which can be used to concentrate on the electromagnetic and related problems. In this thesis, we utilized HFSS (High Frequency Structural Simulator), which is a commercial electromagnetic structure solver based on finite element method.

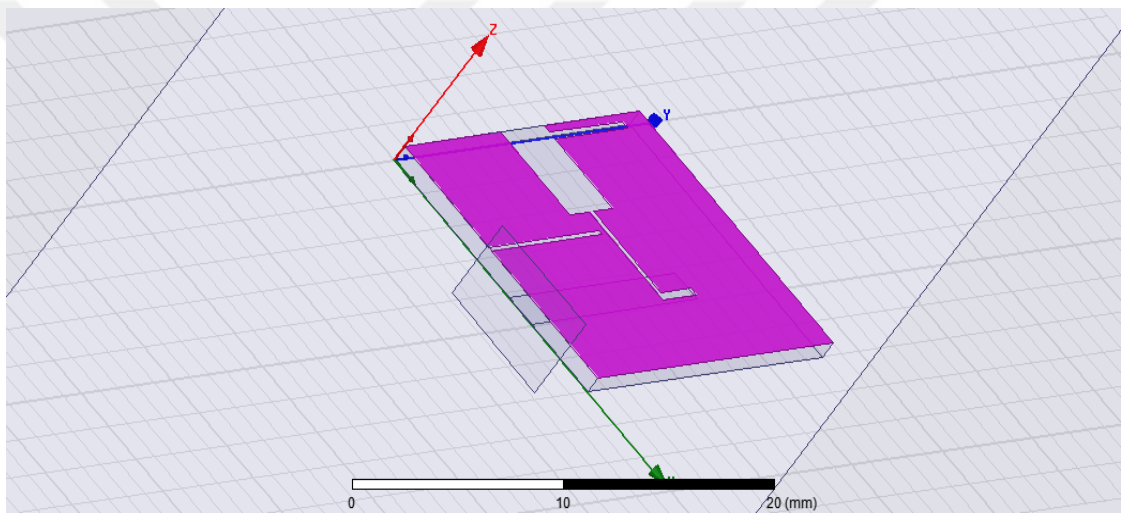

Figure 3.2. The proposed Antenna by HFSS.

At the beginning, we simulated the same geometry in Figure 3.1 with the same dimensions. After that, we changed the thickness of the substrate and compared the results between the two cases, and then we concentrated on the effect of the slots with the second thickness.

For this design, the dimensions are as follows:

Table 3-1. The dimension of the proposed antenna in mm.

Symbol	W	L	a_f	w_f	L_f	W_1	L_3	L_1	L_2
dimension	16	28	8.3	1.6	18.4	4.8	3.7	5	4.9
Symbol	w_{11}	L_{11}	a_{22}	W_{22}	L_{22}	h	a_{11}	W_2	
dimension	0.4	8.1	2	0.22	12.2	0.8	0.4	0.4	

So as to accomplish the dual band, a rectangular slit associated with the broad part of the L-shaped slot and another rectangular slit scratched at the base of the ground plane are connected. The length of the first rectangular slit is set to be around $1/4\lambda$ at the lower frequency $f_1 = 3.1\text{GHz}$, while the length of the second slit is set to be around $1/4\lambda$ at the upper frequency $f_2 = 5.4\text{GHz}$.

3.4 RESULT AND DISCUSSION

3.4.1 Return Loss

The frequency, where the return loss is least, is called center frequency. The bandwidth of the antenna is calculated from the return loss plot. The worthy level of return loss is equivalent or littler than -10 dB, which can be seen in Figures 3.3 and 3.4.

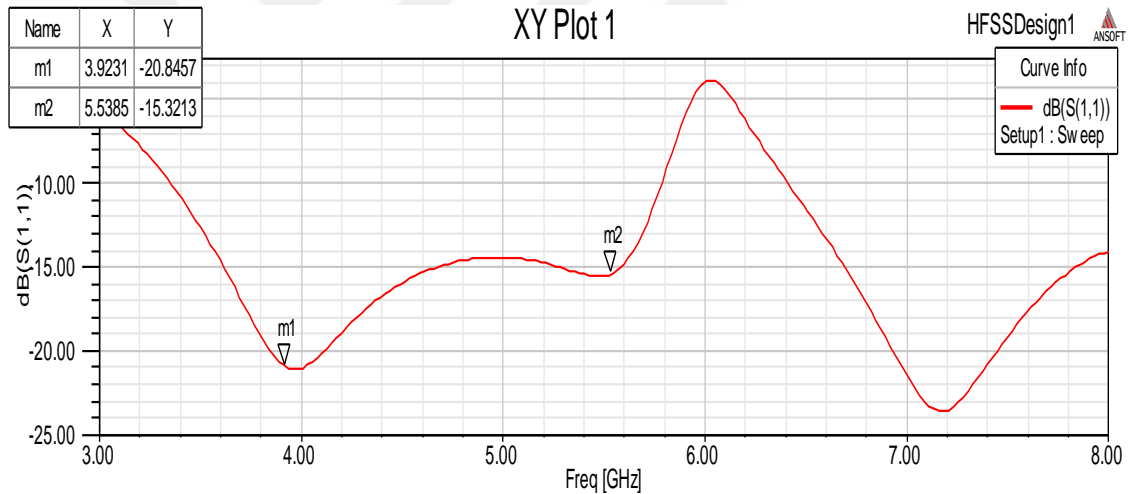

Figure 3.3. The return loss at 0.8mm of height.

After this, we changed the thickness of the substrate to 1.6 mm and optimized. The optimization gave the same dimensions as in the previous case except l_{11} was 7mm. After that, we showed the effect of slots with this dimension, which will be discussed in the next section. Figure 3.4 demonstrates the return loss at 1.6mm of height.

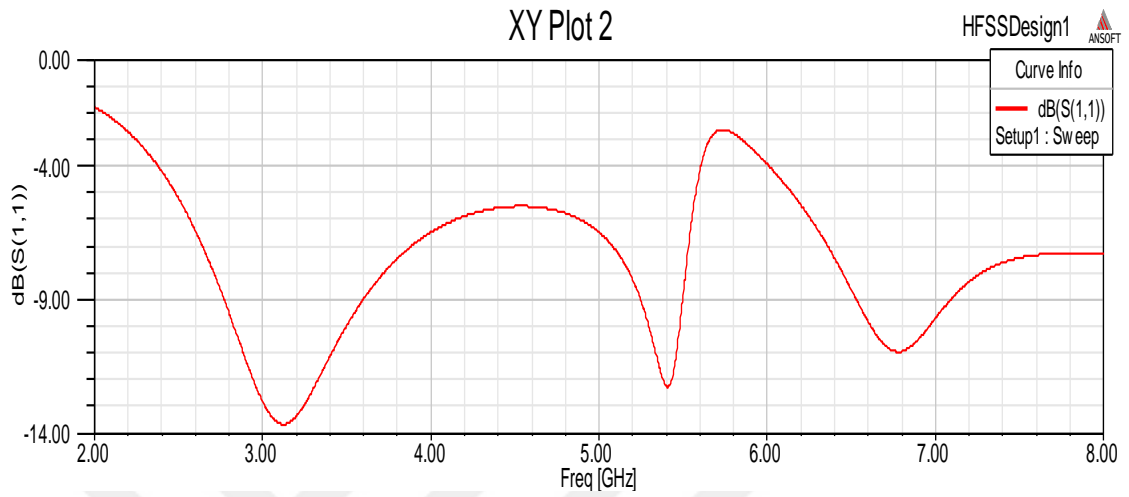

Figure 3.4. The return loss at 1.6mm of height.

A comparison can be made from these results and we can say that the thickness of the substrate is a critical parameter for antenna design. It is understood from this comparison that when the height was increased, the frequency shifted to left.

Table 3-2. The difference between two heights of the substrate.

Substrate height	0.8mm	1.6mm
Dielectric constant	4.4	4.4
Lower frequency	3.9GHz	3.1GHz
Return loss	-22dB	-12dB
Upper frequency	5.5GHz	5.4GHz
Return loss	-15dB	-12dB

From Table 3.2, we found that increasing the thickness of the substrate causes in decreasing the frequency.

3.4.2 Gain

Antenna gain is generally characterized as the proportion of the power created by the antenna from a far-field source on the antenna's beam axis to the power delivered by an ideal lossless isotropic antenna, which is similarly response to signals from all directions [13]. Microstrip antennas are famous for their poor gain since antenna gain is affected by substrate thickness and relative dielectric constant, as shown in Figures 3.5 and 3.6.

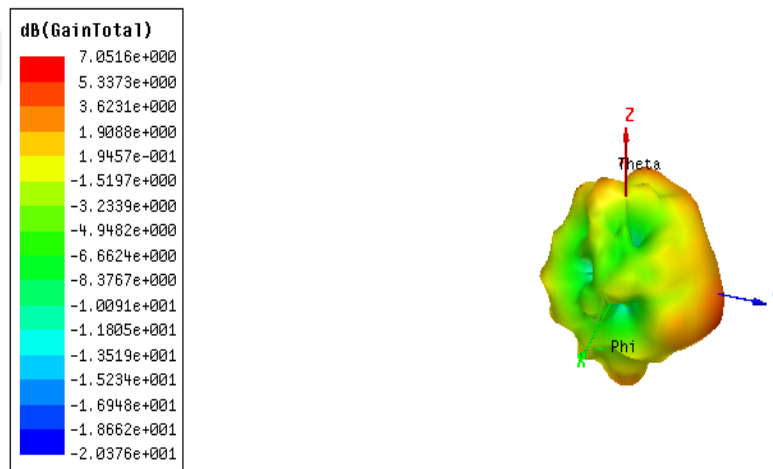

Figure 3.5. The gain of the proposed antenna at 0.8mm of height.

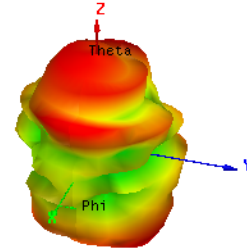
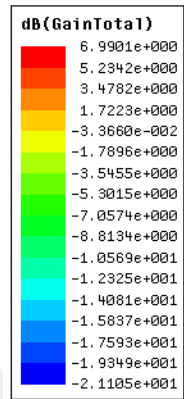

Figure 3.6. The gain of the proposed antenna at 1.6mm of height.

Figure 3.7 will show gain vs frequency for simulation results by using excel program in two dimension (2D).

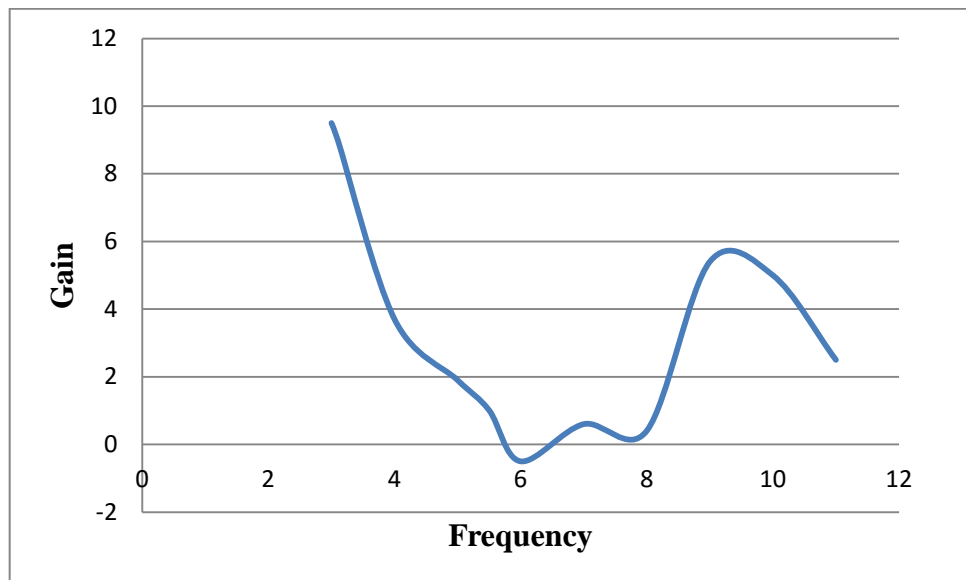

Figure 3.7. Gain vs frequency at 1.6mm of height.

3.4.2 Voltage standing wave ratio

VSWR is resolved from the voltage measured along a transmission line prompting to an antenna, VSWR is the proportion of a standing wave's peak amplitude to minimum amplitude value of the standing wave. Figure 3-8 and Figure 3.9 shows VSWR.

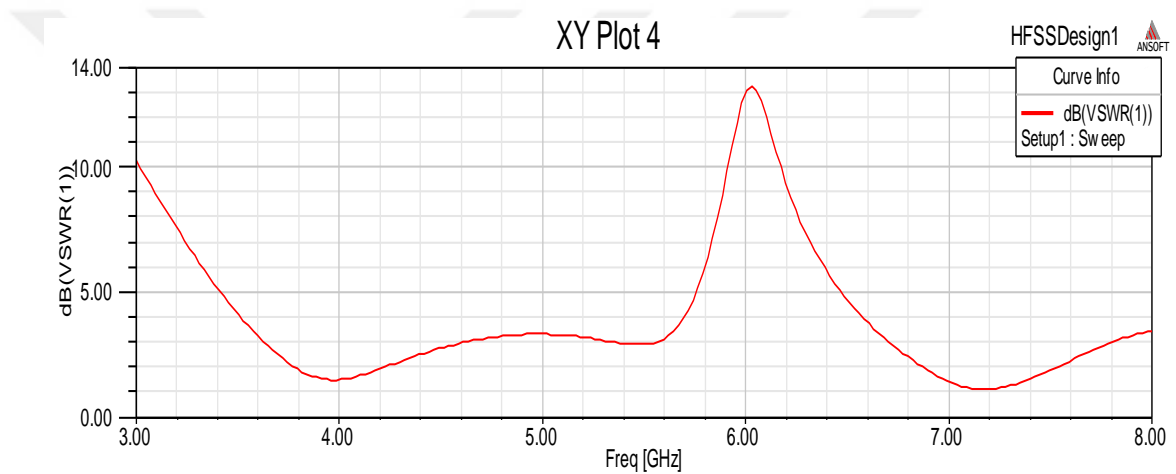

Figure 3.8. VSWR of proposed antenna at 0.8mm of height

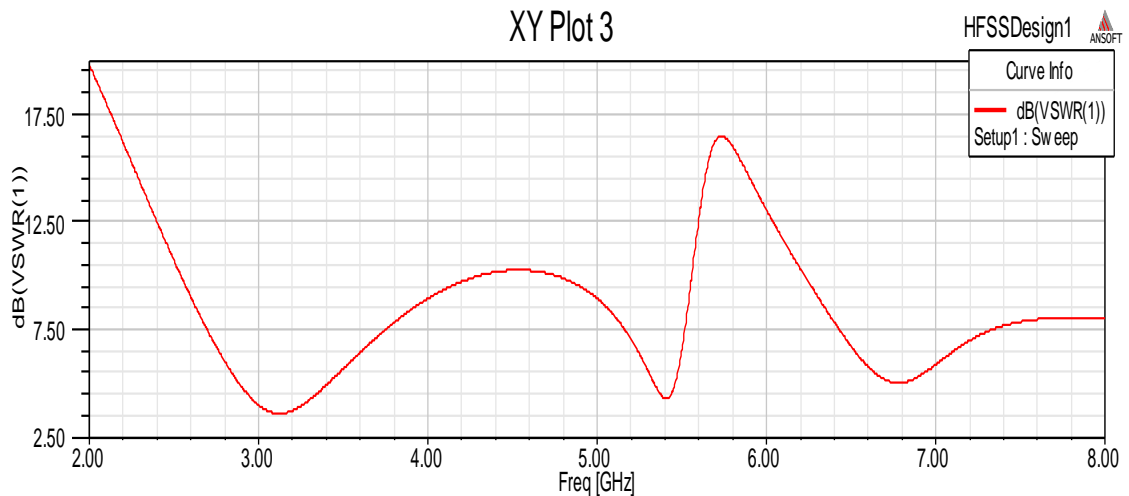

Figure 3.9. VSWR of proposed antenna at height 1.6mm.

Since the voltage does not vary in an ideal system, its VSWR is 1. From figures 3-8 and 3-9, When the thickness of the substrate was 1.6mm the VSWR was close to 3.5 dB at the frequency 3.1 GHz this is the best compared with a thickness of 0.8, Which was 7 dB. Same compared with high frequency (5.4GHz) in the higher thickness was better than lower thickness.

As mentioned before, there are two slots, one effecting lower frequency (near 3.5GHz) and the other effecting upper frequency (near 5.5). Their effect is shown thereafter.

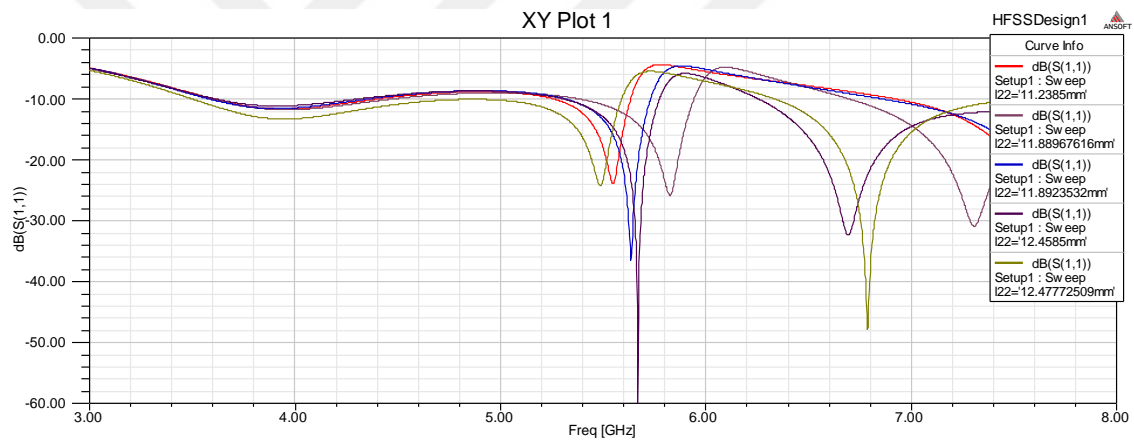

Figure 3.10. The effect of length slot22 at 3.5 GHz.

It was understood from the figure 3-10 that the effect of length slot22, which is the length of slot affecting lower frequency with width, was constant only on return loss but the frequency was better from 3.5GHz to 3.9GHz when length slot22 was 11.2385mm.

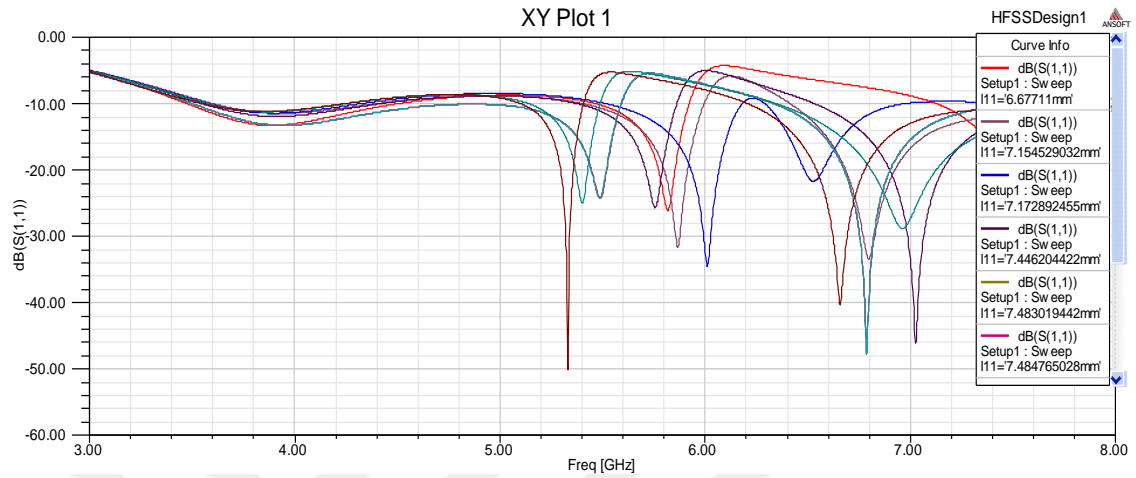

Figure 3.11. The effect of length slot11 at 5.5GHz.

slot width w11=0.4mm

Table 3-3. The effect of length slot11 on resonant frequency and return loss.

length of slot11	Frequency resonant fr (GHz)	Return loss dB
6.6	6	-37.50
7.2	5.9	-19
8.28	5.7	-20
7.69	5.6	-22
7.4	5.5	-21
8.1	5	-31

From previous Table 3-3 and Figure 3-11 we can see how the length of slot11 can effect on frequency and return loss (best result at 7.6mm).

3.5. DISCUSSION

Due to additional slot, surface current paths of the resonant mode can be lengthened, resulting in the decrease of corresponding resonant frequency. Return loss and antenna gain variation with the slot lengths gradually decrease, which establishes the true fact that, as we cut the slot, the radiating patch area becomes lower reducing antenna gain and return loss.

CHAPTER 4

ANTENNA FABRICATION AND MEASUREMENT

4.1 INTRODUCTION

Fabrication of the antenna was finished with the substrate and dimensions described in chapter three in the simulation section. The patch antenna was etched on epoxy FR4, which has a dielectric constant 4.4 and a thickness of 1.6mm.

4.2 SMALL DUAL BAND SLOT ANTENNA

It should have been more careful and precise between simulation and acknowledgment while the software is able to model and read any design in the range of its library data. However, different errors may occur during the fabrication process in this thesis.

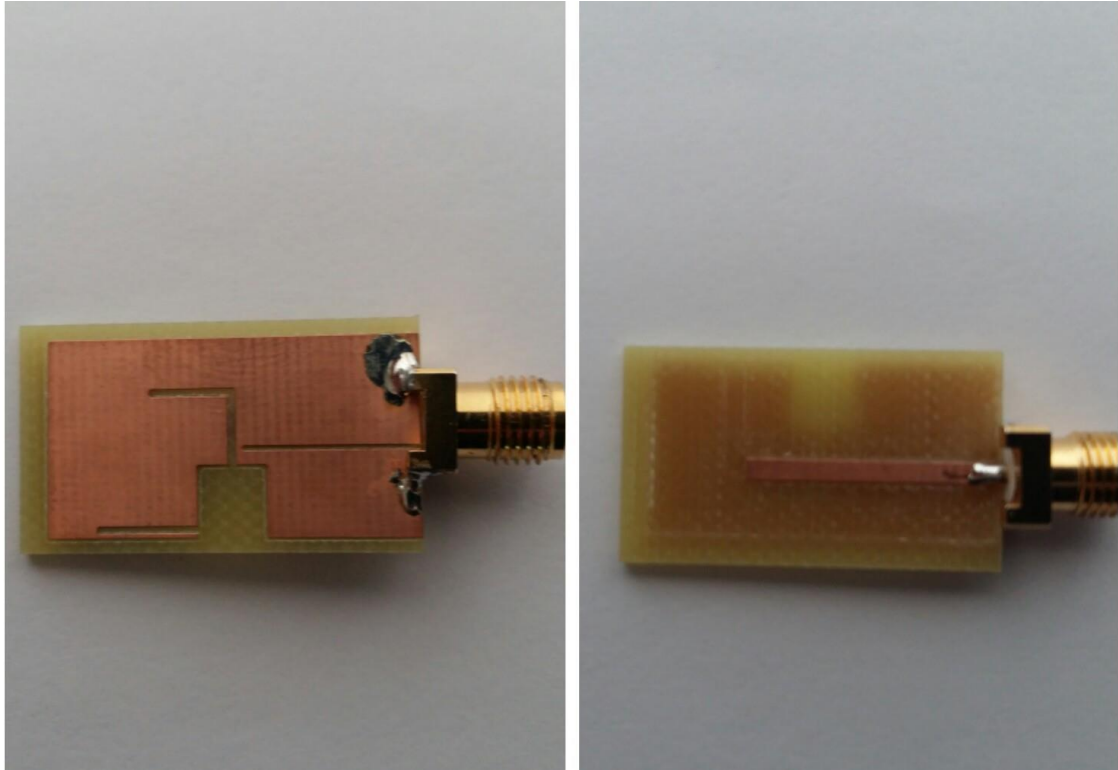

Figure 4.1. Top and bottom side of antenna fabrication.

Figure 4.1. shows the fabricated antenna, which is ready to be measured by the vector analyzer, an instrument that measures the network parameters of electrical networks. Today, network analyzers commonly measure S-parameters because reflection and transmission of electrical networks are easy to measure at high frequencies [13]. In figure 4.2, the return loss measurement of vector analyzer is shown.

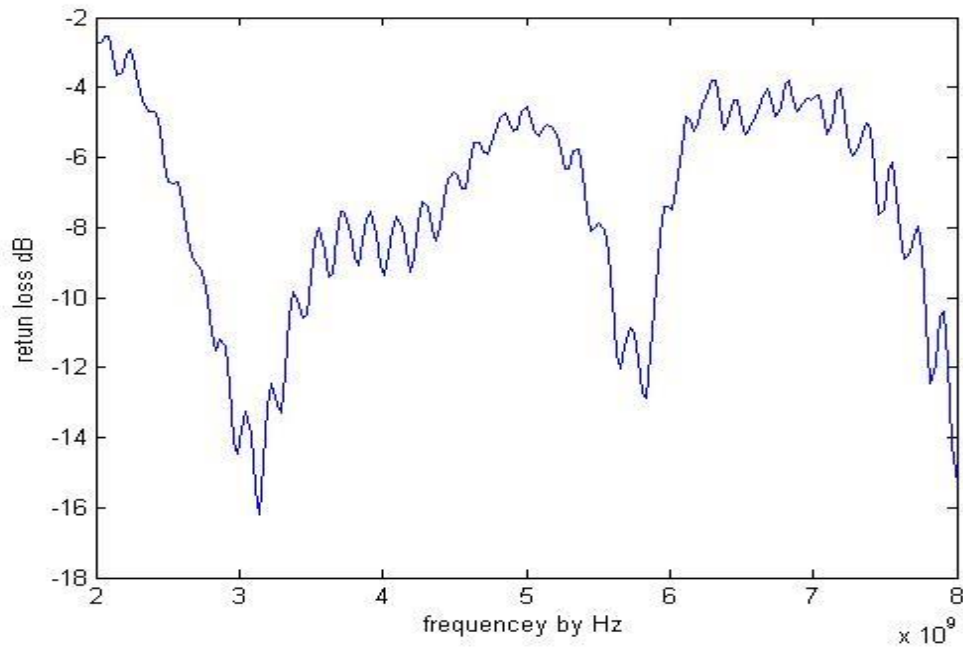

Figure 4.2. Return loss measurement.

In Figure 4.2 the high resonance frequency is 5.6GHz with -12.29 dB, And the lower frequency is 3.1 with -17 dB in measurement result.

Table 4-1. Comparison between simulated results and fabricated results.

Symbol	Simulation	Measurement	Simulation	Measurement
Frequency (GHz)	3.1	3.1	5.4	5.6
S_{11} (dB)	-13	-17	-12	-12.29
BW	$3.4-2.8=0.6$	$3.3-2.8 = 0.5$	$5.47-5.3=0.17$	$5.8-5.59=0.21$
Error	0		$(5.65-5.59)/5.6$ =0.001	

If the simulation results from chapter three, which is mentioned in Figure 3.4., is compared, the comparison will be clear in table 4-1.

From table 4-1, we can see that the resonance frequency is shifted from 5.4 to 5.6GHz with error 0.001.

4.3 Measurement of Gain

For the measurement of the gain of antenna, first we used two horn antennas (WR284 to WR28) to create a communication system. Secondly, we measured all the losses of the system and we used some information from the data sheet. All of these steps will be shown in the next equations:

$$Pr = Pt - L_1 - Lc_1 + Ga_1 - Plf + Ga_2 - L_2 - Lc_2 \quad (4.1)$$

Pr is the receiver power, Pt is the transmitter power, L_1 and L_2 are losses from two cables, Lc_1 and Lc_2 are losses from two connectors, and Plf is path loss.

We defined free space loss as the ratio of the received power to the transmitted power.

We can calculate Plf from next equation:

$$Plf = 32.45 + 20\log(d) + 20\log(fr) \quad (4.2)$$

d is the distance between two antennas by Km and fr is operation frequency [14].

We can calculate the distance by next equation [15]:

$$d > \frac{2D^2}{\lambda} \quad (4.3)$$

In this case, the distance must be greater than 1m.

All losses did not change between the two measures because we used the same cables (sma cable) and two connectors, G_{a1} and G_{a2} , which are 15 dB, from the data sheet we applied 0dBm for transmitter power. This calculation was the reference. We used generator and spectrum analyzer to calculate the transmitter power and receiver power. All these measurements were performed in laboratory setting. Figure 4-3 shows the system.

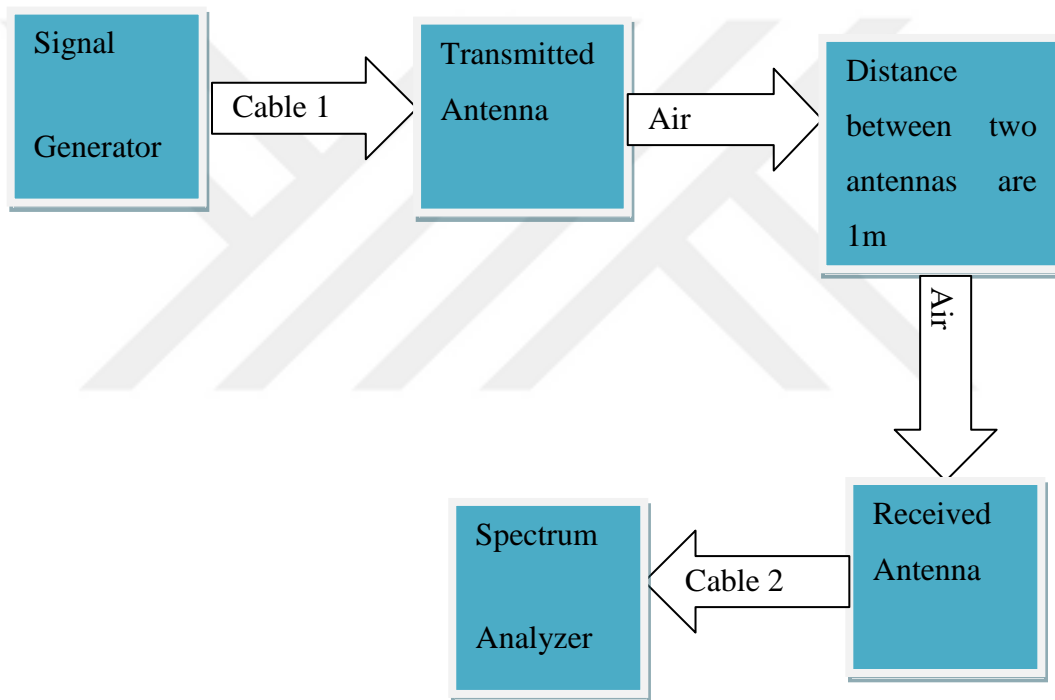

Figure 4.3. Block diagram of gain measurement system

After that, we measured the receiver power for horn antenna which was -31dBm. As the next step, we changed the receiver horn antenna with the proposed antenna with the same material. By changing the receiver antenna, the measure was found as -40dBm.

From the equation (4.1), we calculated the gain at 3.1 GHz

$$-31 = 0 + G_{a_1} + 15 - loss \quad \text{reference antenna} \quad (4.4)$$

$$-40 = 0 + Ga_1 + Ga_2 - loss \quad \text{proposed antenna} \quad (4.5)$$

When (4.4) was subtracted from (4.5), we got the gain of proposed antenna.

Same procedure has been applied to another frequency (5.6 GHz)

Table 4-2 shows:

Table 4-2. The comparison between the simulated gain and measured gain.

Parameter	Frequency at 3.1GHz	Frequency at 5.6GHZ
The reference antenna(measured of received power)	-31dBm	-17dBm
Proposed antenna (measured of received power)	-40dBm	-30dBm
The gain (measured)	6dB	2dB
The gain (simulation)	8dB	1.17dB

from this table, we can say that there is broad consensus in gain between simulation and measured.

CHAPTER FIVE

CONCLUSION

Dual band antennas allow you to connect wirelessly for tighter access to locations and are often used for devices such as cellular or dual band wireless access point. The two most common frequencies used in dual band antennas are 2.4 GHz (802.11g / N) and 5.1 GHz (802.11a / N). These two “channels” have differences in terms of their abilities. The 5.1 is a higher frequency and therefore has a smaller range, but can handle more information at the same time. The 2.4 GHZ stretches further and is also better at penetrating surfaces, meaning that it’s better for getting internal connections than the 5.1 GHz. Some dual bands can use both frequencies at once. Depending on which one in your area is better connected, the others can switch between them.

Dual band antennas work on two bands; one of which also works on general household appliances. Sometimes they can interfere with your connection to other technologies, but they can occur in almost every situation where more than one device works at the same time. For many devices, dual band antennas are a stable and easy way to connect to the things you need.

The goal of this thesis was to design a small dual band microstrip patch antenna. Dual band microstrip antenna was simulated and fabricated in this thesis. So as to accomplish the dual band, a rectangular slit associated with the broad part of the L -shaped slot and another rectangular slit scratched at the base of the ground plane are connected. The length of the first rectangular slit is set to be around $1/4\lambda$ at the lower frequency $f_1 = 3.1\text{GHz}$, while the length of the second slit is set to be around $1/4\lambda$ at the upper frequency $f_2 = 5.4\text{GHz}$.

The design of slot antenna having small dimensions with dual bands was proposed. Good impedance matching can be easily obtained by tuning the parameters of the L-shaped slot and the microstrip-fed line, while 3.5 GHz/5.5 GHz bands can be easily generated by embedding two parasitic slits.

In the future, it would be wise to concentrate on how to design small antennas below 1GHz with same advantages like small size and good gain.



REFERENCES

- [1] C. R. Rowell and R. D. Murch, "A capacitively loaded PIFA for compact mobile telephone hand sets," *IEEE Trans. Antennas Propagat.*, vol. 45, pp. 837–842, May 1997.
- [2] K. M. Luk, R. Chair, and K. F. Lee, "Small rectangular patch antenna," *Electron. Lett.*, vol. 34, pp. 2366–2367, Dec. 1998.
- [3] T. K. Lo, C.-O. Ho, Y. Hwang, E. K. W. Lam, and B. Lee, "Miniature aperture coupled microstrip antenna of very high permittivity," *Electron. Lett.*, vol. 33, pp. 9–10, Jan. 1997.
- [4] Jayanti Venkataraman, Andrea Wyant, Wenbo Chen, Aparna Limaye, and George Shieh
Rochester Institute of Technology One Lomb Memorial Drive Rochester, NY 14623, USA.
IEEE.
- [5] R. B. Waterhouse, S. D. Targonski, and D. M. Kokotoff, "Design and performance of small printed antennas," *IEEE Trans. Antennas Propagat.*, vol. 46, pp. 1629–1633, Nov. 1998.
- [6] H. K. Kan and R. B. Waterhouse, "Size reduction technique for shorted dipoles," *Electron. Lett.*, vol. 35, pp. 948–949, June 1999.
- [7] D. Bonafacic and J. Bartolic, "Compact active integrated antenna with transistor oscillator and line impedance transformer," *Electron. Lett.*, vol. 36, pp. 1519–1521, Aug. 2000.
- [8] C.T.P. Song, P. S. Hall, H. Ghafouri-Shiraz, and D. Wake, "Packaging technique for gain enhancement of electrically small antenna designed on gallium arsenide," *Electron. Lett.*, vol. 36, pp. 1524–1525, Aug. 2000.
- [9] Margaret Rouse and Lior Baruch, (2006), wireless, available at :
<http://searchmobilecomputing.techtarget.com/definition/wireless>. (accessed 13 November 2016).

- [10] Dr R.B. Waterhouse. micro-strip patch antennas _A designers. Springer 2010.
- [11] Balanis, Constantine A. Antenna theory: analysis and design. John Wiley & Sons, 2016.
- [12] Malika, Tlili, et al. "Miniaturized on-body patch antenna for 430MHz wireless digestive monitoring system." Biometric Measurements and Systems for Security and Medical Applications (BIOMS) Proceedings, 2014 IEEE Workshop on. IEEE, 2014.
- [13] Zhang, Yong-Ping, and Chun-Mao Li. "Design of small dual band-notched UWB slot antenna." Electronics Letters 51.22 (2015): 1727-1728.
- [14] Mike Willis, (2007), Free Space Loss, available at : <http://www.mike-willis.com/Tutorial/PF4.htm>. (accessed 13 December 2016).
- [15] Bevelacqua, Peter Joseph. Antenna arrays: Performance limits and geometry optimization. ProQuest, 2008.