



**COMPARISION OF HYBRID BARRIER SYSTEM
WITH CONVENTIONAL BARRIERS**

**2021
MASTER THESIS
CIVIL ENGINEERING**

MOHAMMED JALIL ANWER

Thesis Advisor:

Assist. Prof. Dr. Halil İbrahim YUMRUTAŞ

**COMPARISION OF HYBRID BARRIER SYSTEM WITH
CONVENTIONAL BARRIERS**

MOHAMMED JALIL ANWER

**T.C.
Karabuk University
Institute of Graduate Programs
Department of Civil Engineering
Prepared as
Master Thesis**

Assist. Prof. Dr. Halil İbrahim YUMRUTAŞ

**KARABUK
July 2021**

I certify that in my opinion the thesis submitted by Mohammed Jalil ANWER titled “COMPARISION OF HYBRID BARRIER SYSTEM WITH CONVENTIONAL BARRIERS” is fully adequate in scope and in quality as a thesis for the degree of Master of Science.

Assist. Prof. Dr. Halil Ibrahim YUMRUTAŞ
Thesis Advisor, Department of Civil Engineering

This thesis is accepted by the examining committee with a unanimous vote in the Department of Civil Engineering as a Master of Science thesis. July 2, 2021

<u>Examining Committee Members (Institutions)</u>	<u>Signature</u>
Chairman : Prof. Dr. Ali Osman ATAHAN (İTÜ)
Member : Assist. Prof. Dr. Halil İbrahim YUMRUTAŞ (KBÜ)
Member : Assoc. Prof. Dr. İnan KESKİN (KBÜ)

The degree of Master of Science by the thesis submitted is approved by the Administrative Board of the Institute of Graduate Programs, Karabuk University.

Prof. Dr. Hasan SOLMAZ
Director of the Institute of Graduate Programs



“I declare that all the information within this thesis has been gathered and presented in accordance with academic regulations and ethical principles and I have according to the requirements of these regulations and principles cited all those which do not originate in this work as well.”

Mohammed Jalil ANWER

ABSTRACT

M. Sc. Thesis

COMPARISON OF HYBRID BARRIER SYSTEM WITH CONVENTIONAL BARRIERS

Mohammed Jalil ANWER

**Karabük University
Institute of Graduate Programs
The Department of Civil Engineering**

Thesis Advisor:

Assist. Prof. Dr. Halil İbrahim YUMRUTAŞ

July 2021, 84 pages

One of the leading causes of passing away in our country, like in the rest of the globe, is traffic incidents. When traffic incident data are analyzed, it is well understood that the mortality or injury rates caused by errant vehicles are astounding and are dependent on the properties of the obstacles. Steel, concrete, wood, and plastic are the most common barrier materials used around the world, each with its own set of advantages and disadvantages, such as construction time, easy installation, low price, demonstrated efficacy, crash defending, reliability, life-time, and maintain. Because of the protection and structural demands, aesthetic considerations have still not been kept in mind for the design of obstacles in general, and wooden barriers in particular have been overlooked. The hybrid barriers brought a different aspect in terms of aesthetics. The aim of this study is to observe the crash performance of the hybrid (wood+sand) barrier and compare with the conventional ones (steel and concrete) according to the EN 1317 standards by carrying out

experimental pendulum crash tests by using 1500 kg pendulum device. The results showed that the hybrid and w-beam barrier have near performance in term of Acceleration Severity Index (ASI) and working width not exceed the standards but meet the requirements but the concrete barrier failed due to its high ASI according to EN 1317 standard. This study will be the first step for validation and verification process of virtual testing and for real-time crash testing of aforementioned road restraint systems.

Key Words : Hybrid barrier, Steel guardrail, Concrete Barrier, Working width, Acceleration severity index (ASI), Pendulum crash test.

Science Code : 91124

ÖZET

Yüksek Lisans Tezi

HİBRİT BARIYER SİSTEMİNİN GELENEKSEL BARIYERLER İLE MUKAYESESİ

Mohammed Jalil ANWER

Karabük Üniversitesi

Lisansüstü Eğitim Enstitüsü

İnşaat Mühendisliği Anabilim Dalı

Tez Danışmanı:

Dr.Öğr.Üyesi Halil İbrahim YUMRUTAŞ

Temmuz 2021, 84 sayfa

Dünyanın geri kalanında olduğu gibi ülkemizde de ölümlerin önde gelen nedenlerinden biri trafik kazalarıdır. Trafik kazaları verileri analiz edildiğinde, yoldan çıkan araçların neden olduğu ölüm veya yaralanma oranlarının şaşırtıcı olduğu ve engellerin özelliklerine bağlı olduğu görülmektedir. Çelik, beton, ahşap ve plastik, dünya çapında en yaygın olarak kullanılan bariyer malzemeleridir ve her birinin inşaat süresi, kurulum kolaylığı, maliyet, çarpışma performansı, güvenilirlik, hizmet ömrü, bakım onarım kolaylığı gibi birtakım avantaj ve dezavantajları vardır. Güvenlik ve yapısal talepler nedeniyle, genel olarak trafik bariyerlerinin tasarımı için estetik kaygılar dikkate alınmamış ve özellikle ahşap bariyerler göz ardı edilmiştir. Bu çalışmanın amacı, EN 1317 standartlarına göre gerçekleştirmiş olan deneysel pandül çarpışma testleri neticesinde hibrit (ahşap + kum) bariyerin performansını gözlemlemek ve konvansiyonel bariyerlerle (çelik ve beton) karşılaştırmaktır.

Sonuçlar, hibrit ve çelik bariyerlerin ASI açısından benzer performansa sahip olduğunu ve çalışma genişliği açısından ise her ikisinin de standartları karşıladığını ancak beton bariyerin ASI değeri açısından başarısız olduğunu ortaya koymuştur. Bu çalışma, simülasyon testlerinin doğrulanması süreci ve yukarıda bahsedilen trafik bariyerlerinin gerçek zamanlı çarpışma testleri için ilk adım olacaktır.

Anahtar Kelimeler : Hibrit bariyer, Çelik otokorkuluk bariyer, Beton bariyer, Çalışma genişliği, Çarpışma Şiddeti İndeksi, Pandül çarpışma testi.

Bilim Kodu : 91124



ACKNOWLEDGMENT

First of all, the most gratitude to ALLAH who has guided me to the right path of Islam and with his aid I complete this work.

I would like to this opportunity to thank all those to whom I owe gratitude for their patience and help. Great appreciation is due to Assist. Prof. Dr. Halil İbrahim YUMRUTAŞ, for his direct supervision, contact advice, construction criticism, continuous support and encouragement which facilitate the completion of this work possible.

Lastly, and in no sense the least, my whole-hearted gratitude and special thanks to my father, my mother and my sister (Hawzhin) for their continuous support, patience and continuous encouragement who made this research possible and assistance to complete this work without whom I could not be here now. I will always be indebted to them for their help.

In Conclusion, I hope that this piece of work would be useful and helpful for my own country and hoping that the government will put it into practice. Thus, I will begiven the chance to benefit my country and my countrymen.

This study was funded by Karabuk University Coordinatorship of Research Projects under grant no. FYL-2020-2205

CONTENTS

	<u>Page</u>
APPROVAL.....	ii
ABSTRACT.....	iv
ÖZET.....	vi
ACKNOWLEDGMENT.....	viii
CONTENTS.....	ix
LIST OF FIGURES.....	xi
LIST OF TABLES.....	xiv
SYMBOLS AND ABBREVIATIONS INDEX.....	xv
PART 1.....	1
INTRODUCTION.....	1
PART 2.....	7
LITERATURE REVIEW.....	7
PART 3.....	17
CONVENTIONAL BARRIER TYPES.....	17
3.1. STEEL BARRIER.....	18
3.2. CABLE BARRIER.....	24
3.3. CONCRETE BARRIER.....	27
3.4. PLASTIC BARRIER.....	29
3.5. TIMBER BARRIER.....	30
PART 4.....	33
MATERIAL PROPERTIES OF THE BARRIERS.....	33
4.1. HYBRID BARRIER DESIGN.....	33
4.1.1. Wood.....	34
4.1.2. Concrete Base.....	35

	<u>Page</u>
4.1.3. Steel Profiles.....	36
4.1.4. Sand.....	36
4.2. STEEL BARRIER.....	39
4.3. CONCRETE BARRIER.....	42
PART 5	44
THEORY AND METODOLOGY OF EXPERIMENTS	44
5.1. STANDARDS FOR ROAD RESTRAINT SYSTEMS.....	44
5.2. EN 1317 PERFORMANCE CRITERIA.....	48
5.2.1. Classes of containment.....	49
5.2.2. Working width.....	51
5.2.3. Acceleration Severity Index (ASI).....	51
5.3. HYBRID BARRIER PENDULUM SYSTEM	52
5.4. FINITE ELEMENT ANALYSIS.....	59
5.5. DATA PROCUREMENT	62
5.6. APPLICATION OF EXPERIMENTS	63
5.6.1. Hybrid Barrier	64
5.6.2. Concrete Barrier	64
5.6.3 Steel Barrier.....	65
PART 6	68
RESULTS	68
PART 7	71
DISCUSSION	71
REFERENCES.....	73
RESUME	84

LIST OF FIGURES

	<u>Page</u>
Figure 1.1. Amount and rate per 100,000 population of road traffic deaths: 2000-2016 [6].	1
Figure 1.2. Fatality rates for road collisions in selected countries [17].	3
Figure 2.1. Steel post timber barrier [56].	14
Figure 2.2 (a,b). Wooden Post barrier [57,58].	15
Figure 2.3. Wooden element guardrail [1].	15
Figure 3.1. W-beam guardrail with timber post [72].	19
Figure 3.2. W-beam guardrail with steel post [73].	19
Figure 3.3. Tubular beam barrier [74,75].	20
Figure 3.4. Thrie beam guardrail [15].	20
Figure 3.5. Steel tubular bridge barrier [75].	20
Figure 3.6. Steel beam guardrail deformation [77].	21
Figure 3.7. A motorcycle accident in a steel guardrail [83,84].	22
Figure 3.8. Steel beam guardrail terminal hazard [86].	23
Figure 3.9. Steel guardrails terminal hazards [87].	23
Figure 3.10. Cable barrier applications [90].	24
Figure 3.11. Wire rope detailing [90].	25
Figure 3.12. Under riding of vehicle due to wire rope [13].	26
Figure 3.13. a) F-shape concrete safety barrier, b) Single-slope concrete barrier [114].	27
Figure 3.14. a) New jersey concrete barrier, b) Vertical concrete barrier [114].	28
Figure 3.15. Design criteria of anti-climbing barrier [98].	29
Figure 3.16. Plastic barrier application [13].	30
Figure 3.17. (a,b) Full timber guardrail [101].	31
Figure 4.1. Parts of HBS (a), Appearance of HBS on road platform (b) [60].	33
Figure 4.2. Dimensions of timber parts used on the walls of a Hybrid Barrier [60].	35
Figure 4.3. Concrete base dimensions (mm).	35

	<u>Page</u>
Figure 4.4. Metal profile dimensions used in the production of HBS (mm) (a), Connection points of RHBs (b and c).	36
Figure 4.5. Placement of sand inside Hybrid Barrier.....	37
Figure 4.6. Sand pad use in rock protection tunnel [111].	39
Figure 4.7. Dimensions of steel guardrail (mm).	40
Figure 4.8. Rail and posts.....	41
Figure 4.9. Concrete barrier shape.	43
Figure 4.10. Dimensions of concrete barrier.....	42
Figure 5.1. Nominal <i>KE</i> for longitudinal barriers for NCHRP 350, MASH, and EN 1317, utilizing vehicles with a mass of less than 16 tons [117].	45
Figure 5.2. Small car test vehicles: (a) EN 1317, (b) NCHRP 350, and (c) MASH [117].	45
Figure 5.3. Larger test vehicles: (a) EN 1317, (b) NCHRP 350, and (c) MASH [117].	46
Figure 5.4. Collision energies emerging (Containment Level) in acceptance tests according to EN 1317 standard.	50
Figure 5.5. San Antonio, Texas southwest research institute pendulum [125].	53
Figure 5.6. Configuration of 820 kg pendulum used in 1998 [126].	54
Figure 5.7. Details of 2000-kg pendulum used in 2010 [127].	55
Figure 5.8. Configuration of 2000-kg pendulum used at FHWA and FOIL [128]. ...	56
Figure 5.9. Experimental pendulum crash system.	57
Figure 5.10. Crash test example TB31.....	58
Figure 5.11. The accelerometer device.	62
Figure 5.12. 7.5 cm in diameter vector illustrators.	63
Figure 5.13. yellow line to fix the starting point of each experiment.	63
Figure 5.14. Optimum sufficient test length of hybrid barrier.....	64
Figure 5.15. The installation process of the concrete barriers	65
Figure 5.16. Concrete barrier installation to the crash point of pendulum system. ...	65
Figure 5.17. Concrete cutting machine.	66
Figure 5.18. guardrail post driving machine.	66
Figure 5.19. W- beam steel barrier after installation process.	67
Figure 6.1. Deformation shape of hybrid barrier after crashing with pendulum.	68

Figure 6.2. Deformation shape of concrete barrier after crashing with pendulum. ... 68

Figure 6.3. Deformation shape of w-beam guardrail after crashing with pendulum. 69



LIST OF TABLES

	<u>Page</u>
Table 4.1. Yield and tensile strength values of steel guardrail.	41
Table 4.2. Minimum elongation at break values of steel guardrail.....	41
Table 5.1. Vehicle Specification Under Test Conditions.....	47
Table 5.2. Required performance level.	48
Table 5.3. Crash test criteria according to EN 1317 standard.....	49
Table 5.4. Acceptance tests of containment level according to EN 1317 standard. ..	50
Table 5.5. Working width classes according to EN 1317.....	51
Table 5.6. EN 1317 European standard impact severity levels.....	51
Table 6.1. Working width results of barriers according to pendulum crash test.	69
Table 6.2. ASI classes of barriers according to pendulum crash tests.	70

SYMBOLS AND ABBREVIATIONS INDEX

SYMBOLS

- E_p : Total potential energy
 m : Weight of the rammer
 g : Gravitational acceleration
 h : Height of the rammer

ABBREVIATIONS

- RTA* : Road Traffic Accident
HBS : Hybrid Barrier System
WHO : World Health Organization
AASHTO : American Association of state Highway and Transportation Officials
NCHRP : National Cooperative Highway Research Program
FHWA : Federal Highway Administration
US\$: United States Dollar
LMICs : Low and Middle income Countries
GDP : Gross Domestic Product
FARS : Fatality Analysis Reporting System
KGM : Karayolları Genel Müdürlüğü
OECD : European Organisation for Economic Cooperation
FOIL : Federal Outdoor Impact Laboratory
MASH : Manual for Assessing Safety Hardware

PART 1

INTRODUCTION

The trouble of roadway protection is becoming extra relevant, through with the increment intensity of roadway, needing more observation from all the organizations. RTAs (Road Traffic Accidents) are usually caused by vehicle deviation from the desired direction [1]. Road safety is therefore a worldwide concern, especially on the highway where vehicles are drive rapidly [2]. Further than one and half million motorcycle collisions happen on the roadsides of United States each year in consequence of roughly 1,200,000 damages and more than eight thousand passing away [3]. The WHO (World Health Organization) reported 1.20 million fatalities on the roads of the world in 2012, about 1.25 million in 2015, and about 1.35 million in 2018 due to traffic accidents and the number are growing year by year [4,5]. As illustrated in the Figure 1.1, the number of road fatalities continues to increase, to a peak of 1.35 million in 2016, on the other hand the number of deaths decreases because of road safety measures and development of automotive technology [6].

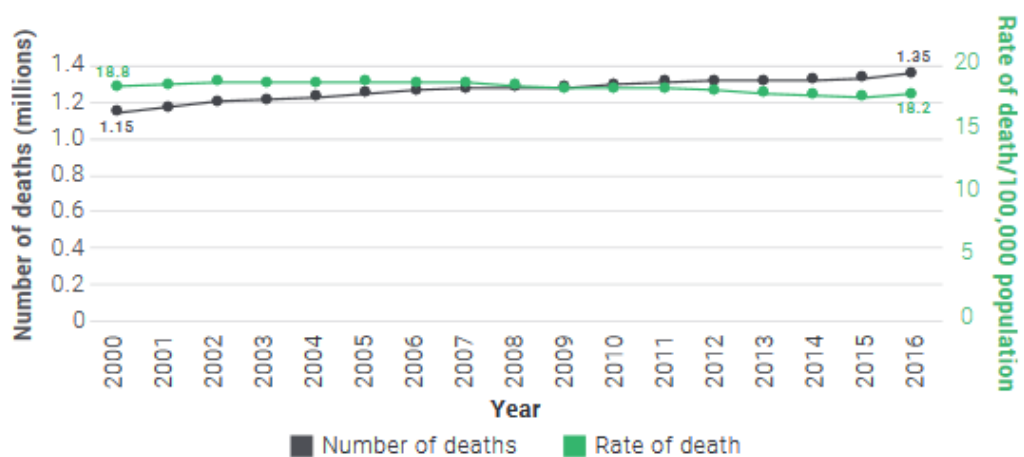

Figure 1.1. Amount and rate per 100,000 population of road traffic deaths: 2000-2016 [6].

The cost to the global economy of RTAs is tremendous [7]. The United Kingdom Transport Research Laboratory Study , released in 2000, estimated that the global cost of RTAs was approximately 518 billion US\$ (United States Dollar) annually, of which 65 billion US\$ is attributable to LMICs (Low and Middle income Countries) [8]. As stated by NHTSA (National Highway Traffic Safety Administration), economic losses due to RTAs in the United States in 2014 amounted to up to 836 billion US\$, and in Australia RTAs cost about 17 billion AUS\$, which is 2.3% of Gross National Income Australia in 2003 [9]. Evaluation of Russia's financial losses due to pass away and injury people in 2015 in RTAs account for 2.2% to 2.6% of GDP (Gross Domestic Product) [10]. In 2014 a study revealed that the cost of traffic incidents in Turkey is more than 4 billion US\$ for the year 2012 [11].

Over the study period (14 years, 2002-2015), the economic cost of traffic incidents in Iraq amounted to 14.8 billion US\$, representing approximately 2.9 million US\$ per day [12].

Road collisions into roadside problems that comprise hitting rigid bodies and overturning account for roughly 40 percent of road mortalities and about 7 percent of fatalities in Australia are caused by cross-over two car frontal collisions [13]. Between year 1997 to 2001, the American accident database FARS (Fatality Analysis Reporting System) estimated that mortal roadside-correlated accidents considered for around 30 percent of the all mortal collisions in the US every year [14]. Using guardrail can stop vehicles from colliding with structures on the roadside, which can minimize the risk of injuries [15,2]. As in the world, road incident are considered to be one of the leading causes of an increase in Iraq's death rate [16]. The traffic incident mortality rate over Iraq in 2013 is 20.2 as indicated in Figure 1.2. This rate is moderately higher globally than 17.4 worldwide rate [17].

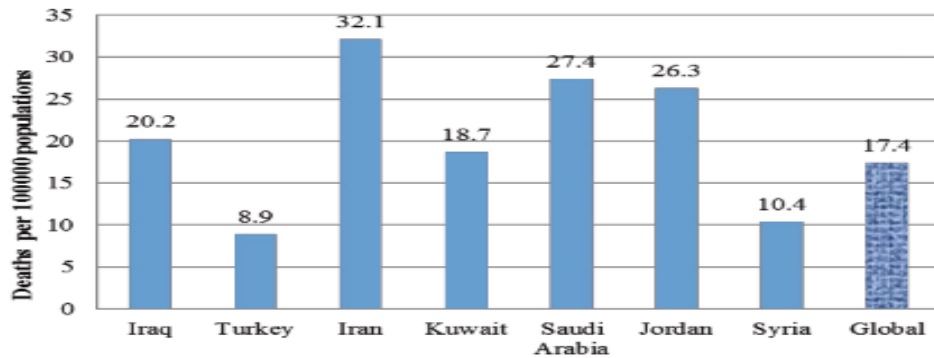

Figure 1.2. Fatality rates for road collisions in selected countries [17].

Although the globe is far from reaching the sustainable development goals objective 3.6 [6]. In 2016, there were a total of 1 million 182 thousand and 491 traffic incidents on Turkey's road network. Of these incidents, 997,363 are financially affected, and 185,128 of them are seriously injured. A study report in (1996) indicated which, traffic accidents are expected to rank sixth among the world's biggest causes of death in the 2020s. Based on a report conducted in the US by Indiana University, it was determined that because of hitting a stationary object on the roadside, most of the deadly incidents happened on rural roads. Fifty-five percent of these accidents are caused by stationary bodies, 15% by trees, 11% by road cliffs, 10% by road signs and poles, and 9% by road barriers [18].

Internationally, road vehicles that collide with roadside objects (trees, poles, road signs and streetlights, etc.) are a main road safety concern. 18-42% of fatal traffic injuries are caused by such crashes in EU countries. The most significant factors that cause these incidents to happen are the incorrect positioning on the roadsides of the objects. Traffic accidents occurring in Finland between 1991 and 1995 as a result of impacting roadside objects constitute 24% of all fatal traffic accidents. In 1995, roadside collisions with objects in France accounted for 31% of all fatal accidents [19].

According to a report by the Directorate General and Highways (KGM), between 2008 and 2016, 37% of fatal and injured traffic accidents occurred in Turkey due to

errant vehicles or vehicle collisions with roadside obstacles. The death and injury rate in such incidents accounts for 36% of all fatalities and injuries in all accidents in the same year [20].

As stated by a report in Sweden (1997), one in four drivers and passengers died in incidents caused by roadside objects intrusion the car. Fifty percent of the objects hit are trees, 20 percent are guardrails, 10 percent are poles of light, 10 percent are other poles and 10 percent are other objects [21]. Given that 60% of fatal accidents occur with just one vehicle and 70% of them are assumed to be caused by vehicles leaving the lane, either overturning or colliding with a fixed object on the roadside, it is understandable why roadsides should be built to "forgive" driver defects [22].

Additionally, motorcycle drivers are another significant issue that should be considered due to their vulnerability in the accidents, experts point out that in traffic collisions, motorcyclists are subject to 16 times more deaths and 4 times more injuries than in car accidents [23]. Therefore, the appropriateness of roadside safety measures is even more relevant particularly for users of motorcycles.

Over the past 40 years, roadside security analysis has improved dramatically. In a study carried out in the 1960s, it was emphasized that vulnerable road edges are problematic areas and that the use of engineering design is possible to improve road safety [24]. The European Organization for Economic Cooperation (OECD) adopted a study in 1975 on the issue of shielding passengers in collisions with roadside objects. Four core principles for security are set out in the report: (i) Reduction of unwanted obstacles; (ii) Replacement of roadside barriers; (iii) Adjustment of barrier structure; (iv) Separation of barriers with new safety devices [25].

Ensuring that all vehicles stay on the road platform is the best remedy for incidents reasoned by an impact with roadside bodies and/or leaving the road platform. If this is not taken into consideration and steps are not taken, more serious incidents will occur due to errant vehicles leaving the platform. Using engineering techniques, the crucial thing is to mitigate the loss of life and property in these incidents [26]. In recent years, the definition of protection in traffic engineering has been categorized

as active and passive. Passive protection is understood to be road safety measures and instruments, while dynamic driving safety, driving actions, sensing / vision, ergonomics and driving conditions (air conditioning, comfort, etc.) are known as active safety. While the fundamental concept of active safety is to ensure that an accident does not occur, in passive protection, the basic concept is to mitigate the potential losses that can occur in the event of an accident [18].

Passive protection systems, referred to as barriers or guardrails used at the edges and in the middle (refuge or median) sections of roads, are built to shield errant vehicles leaving the road platform. The main aim of the barriers is not to avoid an accident, but to mitigate the severity of the accident and to minimize the harm caused by the accident [27]. Along the impact, the barriers absorb some of the energy produced. Errant vehicles are also slowed down and kept on the road [28]. As a psychological effect, it also allows drivers to keep their focus on the roadway and decreases the risk of incidents. The severity of accidents that can occur in potential collisions with roadside objects (trees, poles, rock surfaces, steep slopes, etc.) is also substantially reduced by barriers [29]. Barrier systems are often hazardous artifacts themselves, even though they are better constructed. In other words, the frequency of an accident may be increased by obstacles, thus reducing the seriousness of accidents. That is why, if the requirement is not clearly determined, barrier systems should not be implemented. As a general notion, the provision of roadside protection without obstacles (even a barrier) on the so-called 'forgiving road' platform is important, and if this is not feasible, the use of barriers should be preferred [23].

Design of barriers are to reservation vehicle passengers from obstacles, such as poles or trees, that can be encountered during a collision. To motorcyclists, however, they are not safe: an investigation in (2007) recorded one thousand and 189 mortal impacts and 35 thousand harms guardrail collisions occurred in the US in 2005. They also analyzed all guardrail accidents that happened in the US among 2000 to 2005: it was found that motorcycles were contributed in less than one percent of all barrier impacts, but computed for more than 30 percent of barrier impact mortalities [15,30].

In traffic safety, two articles are significant. First is the preventing of accidents, and the second is minimizing the severity of accidents once a collision occurs [31]. A good design of the guardrail can minimize the highest crash force and the highest impact acceleration when a collision occurs among a vehicle and the barrier, and can also push the vehicle outside of control to return to a proper trip path [32].

All types of barriers have some advantages and disadvantages when compared to each other. In this study, performance of different types of road safety barriers will be observed and compared to HBS (Hybrid Barrier System) experimentally, by using pendulum as an experiment tool. This study also provides an approach to building a fair and reliable model through the analysis and testing of road safety barrier. In addition, in the future, the recommended model may serve as the basis for roadway protection obstacles to increase the variety of traffic barrier systems.

PART 2

LITERATURE REVIEW

The technical literature includes very little previous study on the new approaches (such as aesthetic appearance, renewable/sustainable materials, environmental effects etc.) to conventional barriers as well as their comparison to each other. In the road platform, roadside safety barriers are used for hazard mitigation that likely to be occur clashed with the offending vehicles. The prime target is to steer the offending vehicle to the pathway in the absence of conducive the passengers of the vehicle to accelerate too much [33]. Several studies were conducted based on standardized crash tests on the capability of various kinds of roadway protection barriers. Barriers to roadway protection are analyzed and appraised either by investigational or arithmetical simulation testing. The investigational manner is a typical way to attaining outcomes in the actual world that are close to those. This method evaluates and improves road safety barriers by a process of: designing, testing, redesigning and testing till the wanted outcomes are attained. For instance, in (2007) a study used heavy trucks to enhance safety of the bridges in Germany to perform impact tests on new protection barriers stand on EN 1317 [34]. Another study in (2014) used steel beam barrier to assess and develop highways of turkey to perform a sequence of full-scale impact tests [2].

The first vehicle that designed only for roadside performance testing was a simple version of the GM Saturn 1991. This framework was evolved for the Federal Highway Administration (FHWA) by manually evaluating the vehicle and producing a basic mechanical equivalent. The template has been used with backup for the slip-base luminaire, a stiff wall and U-post symbol support to simulate a visual collision and then was intended to demonstrate the possibility of using nonlinear analysis of finite elements in the simulation of crash tests [35].

The University of Florida published another ground-breaking simulation study involving guardrails. The paper addressed the design and evaluation of the model of the finitary relation system of the AASHTO G2S, soft S3/6 metal post steel beam barrier. The G2S prototype was affected by an automotive model with a small size of 820 kg. Modeling procedures and techniques were defined for the tenuous post barrier and outcomes of the simulation of the effect of non-linear vibrant finite elements was described. This work was one of the earliest experiments to model a tenuous post, steel beam barrier's crash performance in the literature. Topics like choice of contact techniques, toughness criteria, computation of crash size, specifications of model matters and choices for study, validity of G2S steel beam barrier elements, the specialities of the test vehicle were debated and a G2S prototype with seven steel posts were expanded. The findings of the simulation analyzing were contrasted to the outcomes of the impact test found in Report 289 of NCHRP (National Cooperative Highway Research Program) comprising two G2S guardrails crashed with a car 842 kg in 1979 which moving at 60 kilometers per hour and impacted at 15 ° [35,36].

A median obstacle was used in a research to assess brief and viable cracking. The concrete barrier, with the dimensions 90.5 cm high, 83 cm long at the bottom, and 38 cm wide at the top end, was used in this analysis. The investigators found that the primary fracture was around 0.015 cm to 0.018 cm deep, and it developed for 4 weeks after it was removed from the shape work [37].

In an analysis of 383 km of nether tension half-way cable barriers in North Carolina, it was found that underrun triggered 90 percent of the incidents in which a vehicle hit the cable obstacle. Typically, cable barriers are placed at a 122 cm counterbalanced from the center of the ditch. A simulation study of the underrun incidents was carried out and it was proposed that positioning the obstacles at a 30.5 cm counterbalance from the center of the ditch assists to prevent underrun of the vehicle [38].

In another study a pickup car was used to test two attractive vaulted crossbars, one concrete obstacle, and one steel beam barrier. In terms of safety, the full-size testing

exposed that the crossbar worked good. The angle of the test was 25-degree and the rapidity of the vehicle at 100 kilometers per hour to supply a true picture of the highway for the test. Two kinds of vehicles were used, the first was an 820 car and the second was a 2000 Pick-up, with 100 kilometers per hour crash speeds for both. The first vehicle collided with the barrier at a 20-degree angle, while the second collided at a 25-degree angle. piece of the outcomes was gladder, and adjustments were appropriate for the other aspects of the model [39,40].

A study used two lengths of identical impact to evaluate a concrete obstacle with the distances 600 cm long, 132 cm tall, 42 cm base width, and 23 cm up width. As shown in the AASHTO LRFD (AASHTO long reach fire department) bridge design specification, the long ways distance of the crash force distribution was 107 cm and 244 cm based on test level. during the static evaluation, the two results displayed a weakness mode to simulate a vehicle clashing with the concrete obstacle [41].

The Midwest roadside safety facility outlined the modeling activities and advances in obstacle layout and evaluation. A 3-cable tenuous prop obstacle terminal has been tested in one of the tests. A full-scale impact test carried out on the system using an 820 kg tiny car hitting terminal face on at 100 km/h velocity, the model failed due to vehicle roll-over [35].

Transportation department of Missouri state in America analyzed the action of its nether tension cable obstacle on slopes and found that overlap cannot be avoided in only sixty seven cases out of the 1,402 accidents, which shows a success rate of 95.2 percent in crossover prevention [38].

A study found the necessary qualifications for half-way and roadside obstacles beside slopes. F-shape concrete barriers with prefabricated joins and X-bolts were used. The outcomes illustrated that on inclinations of 1 to 6 or fewer, concrete barriers worked well [42].

A study performed in 2009 on individual slope concrete obstacle 107 cm high, 61 cm base width, and 20 cm up width. The concrete barrier was installed in anterior of

an incline or on a retaining wall. Using a pick-up and a heavy vehicle, this model was evaluated and then simulated through the system of finite elements. The primary topic of this study is the deflection of the barrier [43].

In year (2002) researchers proposes the concept of a network of concrete barriers of low profile for the use in workspace of roadside. A few periods of imaginary design growth are achieved by using computational finite capacity planning extensively [35]. Due to finite element simulations, much of the cost related with the whole size impact test was kept. Using a 2000 kg semi-heavy car which traveling at 100 kilometers per hour and touching the obstacle at 25 degree, and after developing the low-profile obstacle template, the establishing were confronted to automobile crash [35].

Some researchers have chosen the numerical method to evaluate and enhance road safety barriers. In a study that performed in (2010) some investigators used the LS-DYNA finite capacity planning software to create equivalent method of impact testing for roadway protection barriers to show the feasibility of software applications to develop and improve ancient roadway protection obstacles. The findings of disassembling impact tests on a concrete obstacle based on EN 1317 were presented in a study paper and showed the feasibility of using simulation approaches to assess and evaluate road safety obstacles. Another analyses used the arithmetical style to show how disassembling can replace investigational tests for a steel beam barrier system that is strong-post [2,44].

In the year 2000, a computational disassembling was performed to show how missiles impact reinforced concrete obstacles. He devised terms to examine the speed rate, impact angle, and failure behavior of missiles in concrete obstacles [45].

In additional work that conducted in (1996), a revised three beam guardrail was developed, backed by soft W6x9 steel posts with M14 some 17 blockouts. The prototype was clashed with a Ford Festiva 1989, 820 kg Car which initially manufactured and tested to other work in (1994) for clash with a stiff pole. Since making adjustments to the vehicle's side components, chassis and tyres, the vehicle

clashed with the steel beam barrier at 100 kilometers per hour velocity and 18 degree angle of clash [35].

By using LS-DYNA software, an academic researched the New York transferable concrete barrier. The research centered on the sticky splice which connected betwixt the concrete obstacle's two opposite borders. After the adjustment, during the vehicle accident, the findings illustrated enhanced constancy of the transferable concrete obstacle [46].

50 software disassembles of vehicle crash on obstacles applied by finite capacity planning style were completed in (2009). In these simulations, LSDYNA software was used. They performed the experiments using a tiny imitation of a car. To differentiate the styles and the clash tests, and to validate the outcomes of the styles, three crash tests were performed. The research concentrated on accident severity; in this study, barrier performance was therefore significant [47].

A typical crash concrete wall barrier was developed and examined in other contemplator. The prototypes were then disassembled by means of three models of finitary relations. The models were produced using software from LS-DYNA. The degree of the clash test was adjusted, the outcomes were analyzed, the wall clash was simulated, and the wall performance was eventually assessed. The outcome showed that the effect could not be stacked just by the wall, but the head panel clash penetrated the wall [48].

Three collision analysis studies were carried out in (2011) on three kinds of concrete obstacles which used incurved roadways. In order to impact the concrete barrier, the experiments were conducted using 820 C and 2000 P vehicles. Moreover, using a 5400 pickup, four tests were conducted. In the curves where lift nodes were present, they concluded. The impact angle's influence was more critical than that of the curve [49].

By the old standard, road crash barriers for vehicle safety should be made of metal or concrete, whereas in the new standard, instead of specifying the materials used in

barriers, testing protocols for road crash barrier quality have been specified in detail. The revised standard opens the door in road crash barriers for the use of wood materials. A steel-backed lumber timber guardrail, approved by the Federal Lands Highway Office, has been developed as an esthetic barrier installed in scenic areas in the United States. A French private company has developed a composite steel channel and timber log rail system for both vertical and horizontal components by taking advantage of impact-absorbing timber quality and high steel tensile resistance [50].

In (2000) a survey used LS-DYNA to compare the crash acting of two identical powerful timber pole steel beam barrier structures, G4(2W) with G4(1W). The purpose of the disassembling work is to measurement affinity with respect to crash test comportment. Full-size crash test outcomes have been used to verify the finitary relation design of the first guardrail system, G4 (2W). It was determined that the actual crash test quality was accurately represented by the G4 (2W) simulation. The breadth of the G4 (2W) system's poles and counterbalance blocks were then modified to create a style of the G4 (1W) steel beam barrier structure. The G4 (1W) device conducted a second crash test disassembling, contrasting the deformation, automobile reversal, and passenger hazard ratios of two steel beam barrier. The experimental outcomes illustrated which the G4(1W) with G4(2W) systems perform equally in crash tests and either meet the NCHRP Report 350 criteria [35].

Some researcher studied the impact of the bending force on simply supported timber beams by lowering the weight from different heights. Jansson's important in these experiments is that the impact force was directly measured between the drop weight and the sample specimen by means of a load cell. The value of separating the applied load in a part is demonstrated in the analysis of the effects, which introduces bending stresses and a second part that sets the beam in motion. It should be noted that the inertia forces were always disregarded in former timber tests, as they were assumed to be negligible [51].

In (2004) a study informed about one more prosperous simulation of finitary relations on obstacle structure consisting of reused obstacle content poles and

counterbalance blocks. Because of premature post-fractures, earlier whole size test on the obstacle failed, by utilizing 2000 kg semi heavy car which crashed at angle of 25 degree and 100 kilometers per hour speed [35].

In years 2000 and 2007 researchers developed a finitary relations style, that is used to examine the crash mechanism betwixt a pendulum and a semi - rigid obstacle, and built a form of sporadic concrete obstacles to meet collision protection necessities in mountains [32].

Three full-scale experiments were completed by some investigator for two kinds of prefabricated concrete obstacles. During the first test, a 2.041 ton semi heavy car was utilized and in the second test, a 2.024 ton semi heavy car was utilized. A single-unit truck weighing 8 tons was used to make the final one. In the whole size Ford truck, the F-shape precast concrete barrier with 76 kilometers per hour velocity and 15-degree crash angle was tested. Specifications were used to test the precast concrete barriers. During the vehicle's crash against the concrete obstacle, there were minor deflections [52].

Experimental studies were carried out in (2003) to learning the erosion of the reinforce in bridge concrete obstacles. These experiments contained of two components: a fixed test by utilizing whole size concrete obstacle and a 3-ton pendulum crash test. In lieu of the steel reinforcement, both experiments used glass fibre-reinforced polymer. The findings showed a resemblance to traditional reinforced concrete barriers in certain parameters of the proposed barrier [53].

Eight whole size, concrete obstacle in a pendulum collision test were used in (2004). A 3-ton ferrous sphere was on the pendulum. Glass fiber reinforced chemical compound utilized, two concrete obstacles were reinforced and two concrete obstacles using steel bars were strengthened. Various kinds of concrete obstacles have been compared and debated. The findings showed cracking trends in bars, crack widths, and strain. To maximize the results, the deflections and strength exercised in concrete obstacles must have been comprised [54].

In (2008) a thesis study in Boğaziçi university evaluated the performance of roadside barriers of Istanbul city, the comparison study of the barriers was count on the police reports for the accident. In the outcome it was found that performance of weak post w-beam barriers is not adequate with undesired performance rate of 63%, similarly it was found that the barrier design at the gore areas and at the terminal points is especially problematic [55].

Guardrails are the second most frequent objects of collision while they are designed to protect a vehicle's occupants from hazards that can be encountered during a crash, such as poles or trees. Therefore Guardrail development needs to be reviewed with an emphasis on motorcyclist safety [15].

In the international literature, there are overall three sorts of timber guardrail. These; First, the main body is wooden and the posts are steel, secondly the posts are wooden, but the main body is steel and thirdly it is completely wooden as shown in Figure 2.1, Figure 2.2 (a,b), and Figure 2.3. But there is not such a study evaluating a composite usage of wood and sand together.



Figure 2.1. Steel post timber barrier [56].

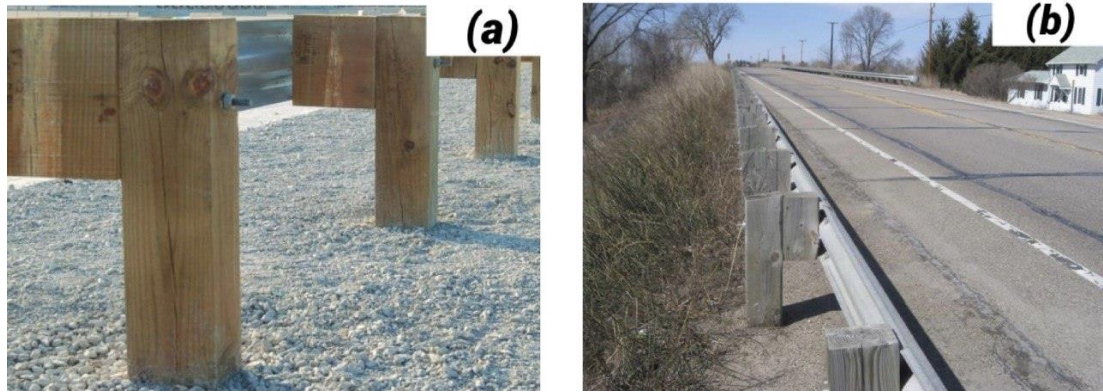

Figure 2.2 (a,b). Wooden Post barrier [57,58].



Figure 2.3. Wooden element guardrail [1].

Some efforts have been made to understand the environmental risks of road safety obstacle systems. The greenhouse gas and carbon emissions of timber or timber initiate barriers were measured and showed its contrast with traditional steel and concrete obstacles over their entire life cycle. The outcome illustrated that the timber and timber initiate obstacles are more amicable because of benefactions of reducing greenhouse gas discharging. More research is needed to expand the range of applications for timber and timber initiate outputs [56,59].

Hybrid barrier system were designed depend on the drawbacks of the conventional road obstacles by utilising timber and sand with extra matter. The elegant aspect of the timber content, its potential energy suction during collision and the cost-cutting influence of sand were all taken into consideration. Flower soil is also put on the upper layer of the hybrid barrier system in the design to plant verdure that can stay green throughout the year. It is hoped that by doing so, the elegant aspect of the vehicle would be improved, as well as the brilliance issue created by approaching cars, which is particularly problematic at night. Hybrid Barriers blend in with the environment thanks to outer timber sections and plant verdure which green throughout the year. To observe the efficiency of the hybrid barrier system in accordance with EN 1317 guidelines, pendulum collision tests and LS-DYNA simulations were used [60,61].

It is self-evident which traffic-related fatalities will continue to rise in lockstep with global activism in latest years. Obstacle issues have been explored by researchers and engineers to withstand collision loads from all types of vehicles, but aesthetic, expense, and environmental considerations have been obscured by structural and safety necessities. The advantages and disadvantages of traditional obstacle systems, as well as the impact of modern obstacle models on the landscape, particularly in scenic/historical/touristic areas, have not been thoroughly debated in the literature. This research is unique in that it compares conventional and hybrid obstacles in terms of efficiency. The performance of the different obstacle kinds was assessed and compared using pendulum crash tests in accordance with the EN 1317 Road safety guidelines. It is hoped that this new obstacle form will be less dangerous for automobiles, particularly motorcycles, and also passengers inside, and will be much more attractive, particularly on scenic roads.

PART 3

CONVENTIONAL BARRIER TYPES

Roadside obstacles are used to avoid an object that has a bigger potential for collision intensity severity than the obstacle itself from entering vehicles that exit the way traveled. Since obstacle are themselves an origin of collision potential, their use should be treated carefully [62]. And the primary function of the traffic obstacle is to reduce the loss of passengers and automobiles and to carry the vehicle back in its usual direction. Instead of the esthetic necessity, engineers pay more observation to safety efficiency and cost during the barrier design and production [63,64]. Among other considerations, the selection of an acceptable obstacle requires consideration of obstacle technical specifications, position qualifications, and costs of erection and maintain. For instance, a concrete obstacle is an acceptable option when an obstacle is chosen for a roadway part with a closed median, fast working speeds, and huge traffic volumes [65].

Particularly, there are three major kinds of road protection barriers: flexible, semi-rigid and rigid and any sort has specific techniques for decreasing vehicle impact incidents with some advantages and disadvantages of each kind [66-68]. Elastic obstacle is built of wire chord supported by posts that are frangible. This sort of barrier is highly flexible. A collision vehicle's kinetic energy is suction by the cable wire, which decreases the vehicle occupant's collision acceleration. Semi-rigid guardrails consist of steel or aluminium and push gradually during a vehicle impacts. They consist of a component of rail and posts of support. Rigid obstacles are built of concrete and are not elastic. The vehicle's collision energy is consumed by the vehicle's deformation [2].

The steel beam barriers, with the different characteristics that may vary according to the height, is the most common barrier [15]. Concrete barriers as a rigid structure are

the second most extensively used sort of obstacles. They give a short term solution or are used where there is minimal roadway length or disfigurement of the barrier. Water-filled road protection obstacles can also be used in road work sites as a semi-rigid barrier. The main advantage is that it is easy to transport and run. Cable median barriers are cost-effective and versatile structures that result in less collision force than concrete obstacle and are easier to maintenance than W-beam steel barriers [1]. On the other side, as effective safety barriers from the ancient period, round logs were used. Increasing the use of timber products in construction has an important environmental impact on the conservation of the natural environment. Considering the value of the impact absorbing performance of wooden material, round logs have been recognized as one type of suitable component of longitudinal barrier railing system [50].

3.1. STEEL BARRIER

It is one of the traditional obstacles which is the longitudinal load transfer framework w-beam steel guardrail belonging to the road foundation, which can alter the path of the vehicles by warping or hopping the vehicle higher to absorb the crash energy to intercept vehicles from crossing the way out or into the opposite lane, minimizing inhabitant hurting [69].

Generally, W-beam guardrail builds of $3 * 10^{-3}$ m thick foil panels with developed strength properties. W-beam segment length is 4.2 m usually, that coupled lengthwise by bolt with splice length of 0.2 m and the cubical spacer, build of $4 * 10^{-3}$ m thick plate, 0.26 m length and 0.22 m height, to connecting the segments with the posts [70].

There are four main types of steel guardrail: W-beams, consisting of a steel or wooden post sustaining a W-shaped steel beam (as shown in Figure 3.1, and Figure 3.2); tubular beams supported by posts of different geometric forms that is rectangular or circular hollow sections (as illustrated in Figure 3.3); Thrie beams, that are basically a dual W-beam, that makes the barrier much rigid than a normal

guardrail beam (illustrate in Figure 3.4); and steel tubular parts on bridge obstacles (shown in Figure 3.5) [71].



Figure 3.1. W-beam guardrail with timber post [72].

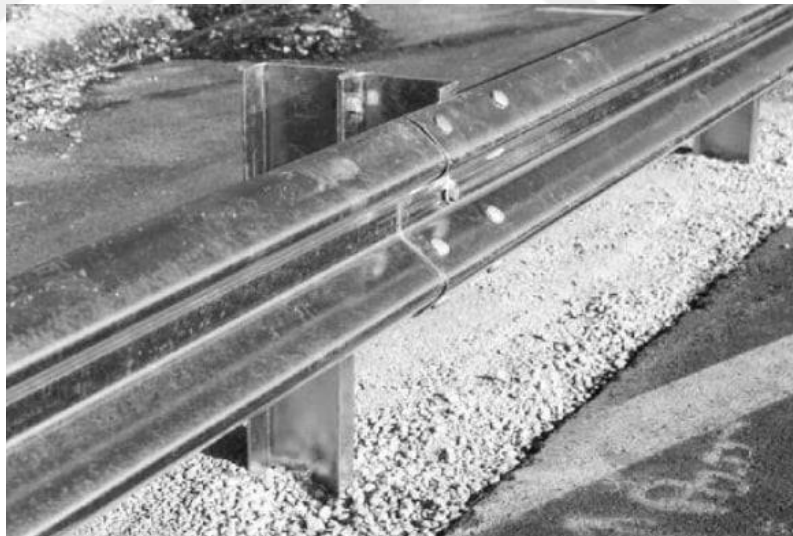

Figure 3.2. W-beam guardrail with steel post [73].



Figure 3.3. Tubular beam barrier [74,75].



Figure 3.4. Thrie beam guardrail [15].



Figure 3.5. Steel tubular bridge barrier [75].

As a semi-rigid structure, w-beam barrier is easy to plant product, the building technique is simple, so it is commonly used on the highway and plays a vital role in the defense of road safety [76]. But this system has several problems, for example it is difficult to remove steel beam guardrail hardware (nuts and bolts) when repairing damaged parts which makes repairs more time-consuming and costly, as shown in Figure 3.6, [77].



Figure 3.6. Steel beam guardrail deformation [77].

W-beam barrier installation can be hard and problematic, due to deep ingrain depth of the posts or narrower post indenting that are typical of these models [78]. As well as w-beam guardrails are not appropriate for steeper areas, relative to the AASHTO, Roadside W-beam barrier must not be mounted slope than 10:1 on roadside slopes [79].

The World's most widely used road safety barrier is the W-beam guardrail [80]. But in accidents involving W-beam steel guardrails, motorcyclists tend to strike the guardrail at a shallow angle, fall and tumble along the tops of the posts. If they slide into the guardrail, they tumble along striking the bases of the posts as shown in Figure 3.7, the post tops and bottoms present edges which tend to concentrate collision forces and accretion the seriousness of harms. W-beam steel barriers and concrete obstacles causing especially hazardous injury to motorcyclists. A motorcyclist is likely to be death fifteen times more than people in a car in the event

of collisions with a fence during impact with posts and can affect a lethal wound at slow speeds so because of uncovered the guardrail posts during slithering with the motorcyclists [81]. Most often, after hitting several forms of open-face roadside obstacles, motorcyclists have been severely hurt or killed, especially after touching the edges of steel guardrail posts or the tops of these posts where they project above the rail element [82]. Statistical data indicate that 73 percent of motorcyclist deaths between 2001 and 2006 participated impacts with W-beams steel barriers and 10 percent-concrete barriers impacts [1].



Figure 3.7. A motorcycle accident in a steel guardrail [83,84].

Alternatively, uncontrolled end terminal sharp steel guardrail that can pierce via vehicle impacts and cause severe deaths and injuries, as shown in Figure 3.8, and 3.9, the momentum of the collision head, accompanied by the deflection of the rail portion as the head is moved down the rail, disperses much of the energy during the collision of the vehicle with an energy-absorbing barrier end terminal. The vehicle hits and accelerates the terminal head through the initial hit, breaks the first post and releases the stress on the rail [85,86].

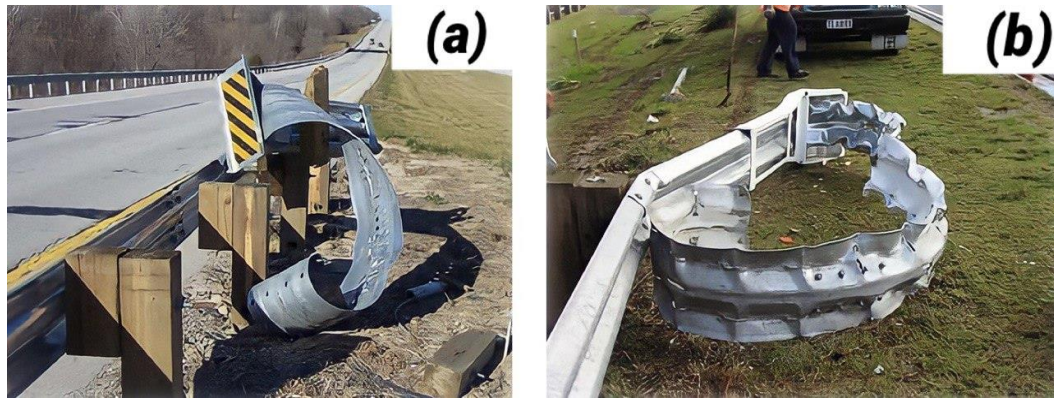

Figure 3.8. Steel beam guardrail terminal hazard [86].



Figure 3.9. Steel guardrails terminal hazards [87].

There have some study about steel beam barrier in the literature for instance in a study weak post steel beam guardrail has been examined according to NCHRP report 350 guide by using a 2000 kg semi-heavy track with impact angle of 26 degree and rapidity of 71 kilometers per hour and the dynamic deflection of the collision was 140 cm. The system was congruence with test level two (TL-2) conditions and failed to test level three (TL-3) conditions with rapidity of 100 kilometers per hour and 25-degree angle of collision because of guardrail break, post-rail contact acting, and guardrail jumping height. After that they utilized two 4.4 cm powerful washer and two nut instead of one to keep the washer from slipping into the hole and to save the bolt threads from being stripped by the nuts as well utilized little bolt (6.35 mm instead of 7.49 mm in diameter) and back plate were also utilized to posts, the height of jumping increased to 82 cm to avert from vaulting over and splice were installed

in the mid span to keep the steel beam from rupturing. At the end the prototype examined by full size test and simulation to congruence with test level three (TL-3) [88].

Another study in Australia evaluated the performance of three rail steel beam guardrail by using three kind of vehicle (800 kg tiny car, 2000 kg semi heavy car and 8000 kg lorry) experimentally and dissembled by arithmetic method at 100 kilometers per hour velocity and 25-degree clash angle for 800 kg tiny car and 2000 kg semi heavy vehicle also 80 kilometers per hour and 15 degrees for lorry clashing with the guardrail. The findings showed that the obstacle is proper to confronting moderate performance level but its biggest deceleration is bigger than allowable limitation for traveler safety [89].

3.2. CABLE BARRIER

Wire ropes that are in common use as structural members are also another form of obstacle that is commonly used, Figure 3.10, show cable barrier applications. Besides that, the use of road cable obstacles and their features impair the productivity of the overall safety system, thus affecting the safety of the passengers of the vehicle through an incident.

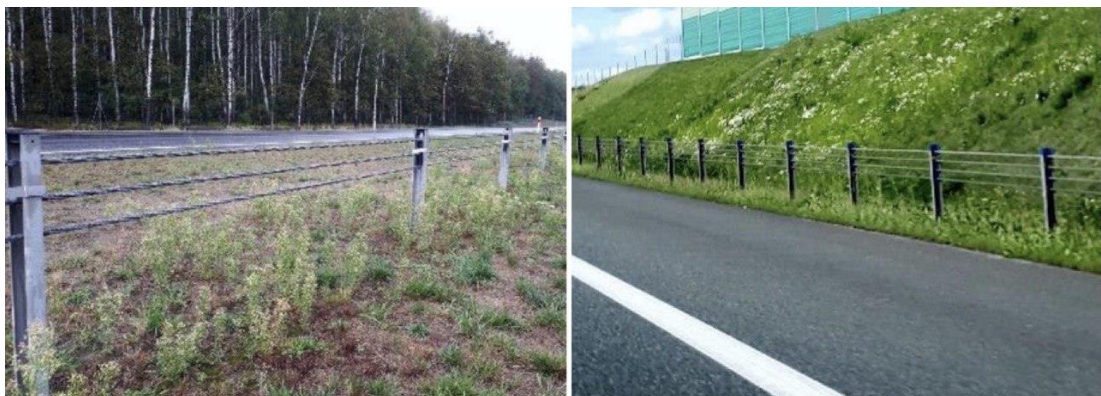

Figure 3.10. Cable barrier applications [90].

A wire rope consists primarily of spirally twisted strands across the middle heart as shown in Figure 3.11, the strand is made up of several spirally bound wires across the internal wire. This indicates that the geometry of the rope will be complex. For transmitting tensile forces, wire ropes are usually used. On relatively tiny dead weights, they have high load-bearing capacity [90]. In the 1940s, the cable or wire rope barrier was used for vehicle protection [65]. While some sources already suggest that it was in the 1930s. Since at least the 1960s, cable obstacles have been used in the United States and the first cable obstacles used were called low-tensioned, standardized cable or U.S. Just customary.



Figure 3.11. Wire rope detailing [90].

Like other barrier systems, the benefit of road cable barriers is that high-tension cable barrier systems can typically withstand several impacts without directly repair and, as a result of their versatile design, cable barriers inflict considerably less pressure on passenger vehicle than concrete obstacles. Likewise, another advantage is the versatile design of cable barriers; they hold vehicles, as opposed to redirecting them back onto the road. It has been shown that the initial cost, installation and maintain of cable obstacles are less costly than the comparable installation of concrete obstacle or median w-beam barriers [66]. Due to the reduction of snow accumulation in areas with high snow drift, it is also beneficial in the snow zone.

The drawbacks are raises hazard to the installation of the obstacle, larger area behind the bending barrier, occasional retension requirements, and the barrier becomes unstable after impact and thus requires faster repairs [38]. One phenomenon that was

found with the regular three-rope cable obstacle system in about all impact tests is that the cables were rapidly disconnected from the support posts for greater distances both downstream and upstream of the hitting vehicle [65]. Although its efficiency along the inside of arcs is decreased [82]. It is also harmful for safety of vehicles in the case of under riding the wire ropes as shown in Figure 3.12, due to numerous causes, including insufficient rope tension due to poor maintenance and installation [13].



Figure 3.12. Under riding of vehicle due to wire rope [13].

In 2011, researchers performed a study both experimentally and arithmetically on a cable made up of 120 wires that was exposed to the clash of a 20-mm small piece traveling at speeds ranging from 720 to 5040 kilometers per hour. The outcomes of computer modeling and the laboratory measurements were in good agreement [91].

Another arithmetical analysis in (2017) looked at the impact of reducing the divisional area on quantity of stress and retained period for three different wire rope model. The findings revealed that reducing divisional areas below 90 percent of the beginning area causes a prominent increment in stress quantities as well as a prominent decreasing in the wire ropes' extant life [92]. In another study published in 2009, the radial loading and hunching of basic wire over a curve were arithmetically investigated. The highest stress was found at the top curve middle point, according to the findings [93]. In 2016, a new systematic methodology and

finitary relation were used to investigate the performance of a chord under radial torque loading. The findings were cross-checked versus experimental and theoretical findings in the literature. Wire put angles as well as the torque boundary's influences were explored [94].

3.3. CONCRETE BARRIER

Concrete obstacles are classified as a solid series of barriers, consisting of reinforced concrete blocks connected to each other to form a continuous line. These sorts of obstacle, rather than roadside guardrail, are more widely used as median obstacles [55].

There are actually four main kinds of concrete obstacle: the concrete barrier of New Jersey, F-shape, single-slope and the vertical concrete obstacle as shown in Figures 3.13, and 3.14, [95].

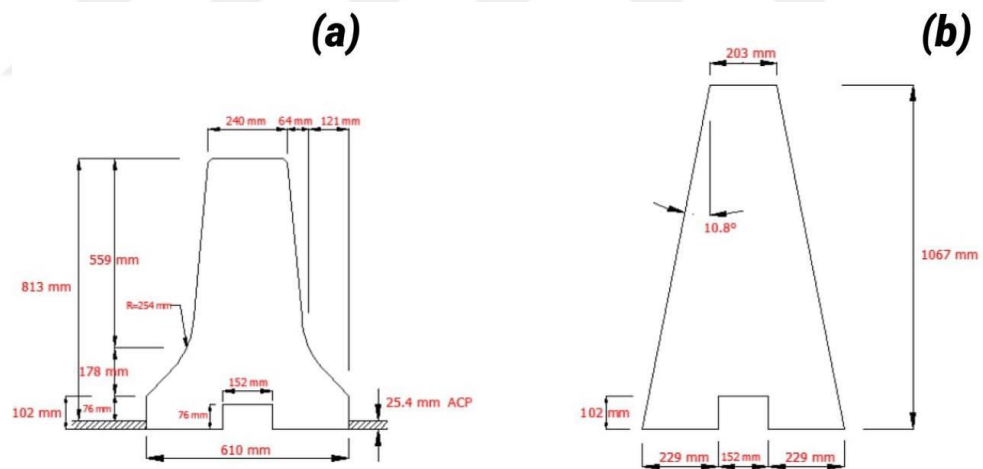

Figure 3.13. a) F-shape concrete safety barrier, b) Single-slope concrete barrier [114].

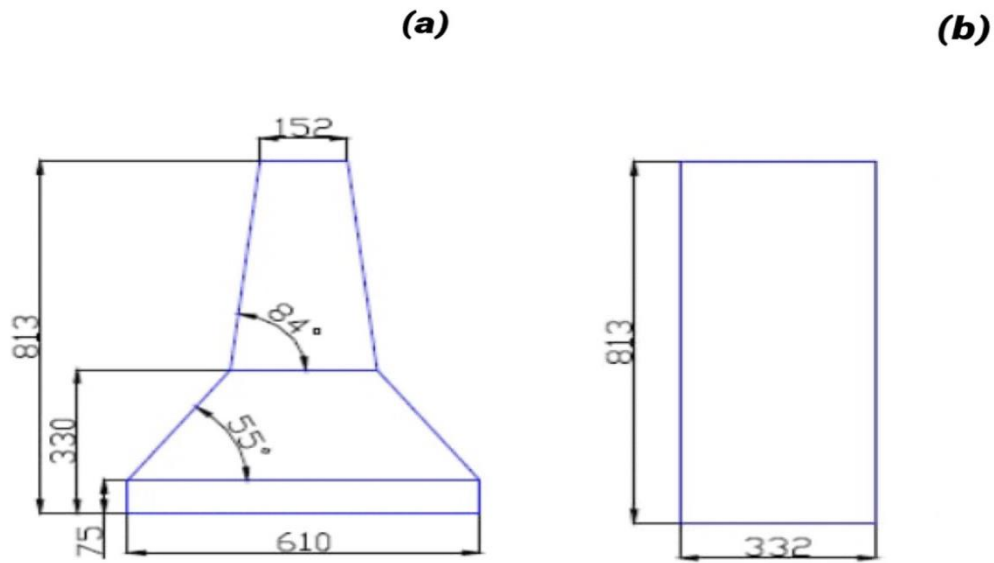

Figure 3.14. a) New jersey concrete barrier, b) Vertical concrete barrier [114].

The New Jersey was excellently assayed with vehicles with a collision range of 820 kg to 2 tons. This form of obstacle often sometimes diverted buses with moderate effects of up to 18 tons. A 36.3-ton trailer at 15° and 84 kilometers per hour has also been effectively diverted by a combination of New Jersey barriers [55]. In California, USA, concrete obstacles were first used in the 1940s. The object was to minimize the amount of errant trucks breaching the barrier and remove the need for expensive and risky maintain of the obstacle in arrow medians [95].

The disadvantage of the concrete barriers are high severity index and during the crashing with vehicles most energy is absorbed only by the vehicles. This high rigidity is demerit to concrete barrier, since cross-median incidents are about three times as serious as other forms of accidents [96]. In addition, concrete obstacle has high initial, construction and maintain costs compared with cable barriers, and concrete barriers are often more invasive to the environment [66]. Likewise, concrete barrier has several advantage, for instance the concrete obstacle is low in maintain and does not normally need repair after an impact [65].

Several studies were conducted about concrete obstacle for example, in a series study various New Jersey and F-shape concrete barriers of 81.4 cm, 94.5 cm, and 106.7 cm

in height were used in to evaluate their properties. The concrete barriers were simulated using a model of finite elements. The findings showed that the roll angle was improved by lowering the height of the concrete barriers [97].

A researcher in (2011) evolved a high concrete obstacle that have anti climbing properties by utilizing a 40-ton heavy truck which traveled at 80 kilometers per hour and compacted the barrier at 30 degrees and through the experiment some factors are designed by using Statistical Product and Service Solutions (SPSS) as illustrated in Figure 3.15, the factors design criteria respectively: A =25 cm, B =75 degree, C =85 degree, D =15 cm, E =30 cm, F =140 cm [98].

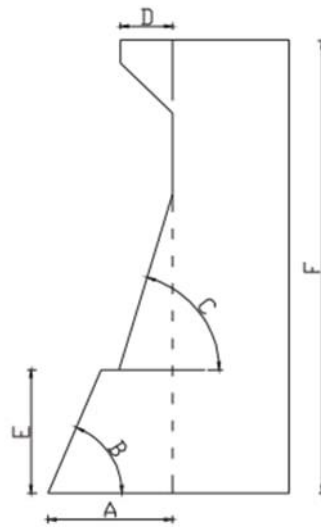

Figure 3.15. Design criteria of anti-climbing barrier [98].

3.4. PLASTIC BARRIER

Another system is a plastic barrier, which is a non-permanent obstacle that is made from plastic polymers to preserve staff in the road work field. Throughout the Tour de France in the 1980's, polymer water-filled modules were first used in Europe as channeling tools. And in early 90's of the last century, they were first brought to Australia with an expanded body dimensions and a range of interconnecting joining methods, later modules followed soon. Figure 3.16, illustrate plastic barrier [13]. As a flexible system, plastic obstacle usually has a lower risk of harm due to its much more resilient nature, their usage is also limited as a result of the space required to

satisfy their high deformations in the design [13]. The working width of these systems can also be as much as three to four meters in the maximum, but no more than one to two meters should be preferred [13].



Figure 3.16. Plastic barrier application [13].

3.5. TIMBER BARRIER

Timber obstacle is another form of roadside defense system, a material with a complex structure, whose key characteristics are isotropy and hygroscopicity. It also has very different mechanical properties between the longitudinal axis and the tangential direction and the radial direction [99].

Generally, three types of wooden barriers are emphasized in the literature. First, the main body is wooden, and the posts are steel, secondly, the posts are wooden, but the main body is steel and thirdly, all parts are wooden. Wood barrier are also considered a more aesthetically appealing option along scenic highways [100,101].

Wooden guardrail is commonly used for urban highways, mountainous and natural roads, historical places and landscape design because of their architectural look. In addition, due to their resistance to corrosion, wooden barriers may be favoured on near the coast roads rather than steel guardrail. But, because of their use of large

solid-sawn wood, timber guardrails are usually costly. In addition, they are comparatively heavy and need a full squad or machine for installation [100].

There have some research and study that performed in the past, in a study a researcher in Germany designed a full wooden barrier to reducing zinc ratio in the surrounding environment which is going to be created because of steel beam guardrail. As illustrated in Figure 3.17, the barrier consisted of two rail one at the bottom which designed to prevent small car and other in the top that was connected to the poles to prevent heavy vehicle during the collision with the barrier. Full size crash test and MADYMO software was successfully used to test the barrier and the system was practically utilized in Netherland [101].

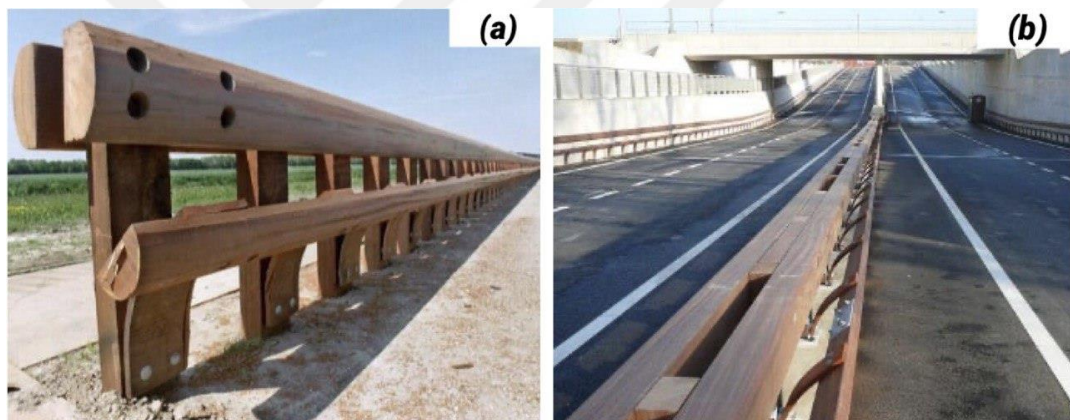

Figure 3.17. (a,b) Full timber guardrail [101].

Another study in (2006) evolved a low cost lightweight wooden obstacle as a replacement of steel by using polymer of fiber reinforced to working as a tightness tool. They used red maple timber with reinforcing a 0.35 cm E- glass of polymer of fiber reinforcement [102].

In (2014) a study developed a timber guardrail with steel in the midst to fortification the barrier and keep wood wasting as saving costs. The barrier consisted of column and two row of beams, which the bottom beam performed as block out. So to assess

the acting of the guardrail full size impact test was performed by using 10-ton heavy track with the rapidity of 60 kilometers per hour and crash angle of 20 degrees, the prototype performed a good performance by redirecting the vehicle with 91 cm deflection and then validated by LS-DYNA software [103].



PART 4

MATERIAL PROPERTIES OF THE BARRIERS

4.1. HYBRID BARRIER DESIGN

HBS (Hybrid Barrier System) raised considering the advantages of wooden material such as aesthetic appearance, impact energy absorbing capability and traffic noise absorbing capability, being a renewable material, and also success in cost reduction and impact energy absorbing of sand together. It is a new generation barrier type that is used together with wood material and sand and is not included in the literature. Additionally, in the design, plant soil on the top of the HBS is placed to grow plants that can remain green for four seasons. Thereby it is aimed to improve the aesthetic appearance much more and to reduce the glare problem caused by oncoming traffic especially during night driving. Figure 4.1, shows a visual of HBS [60,61].

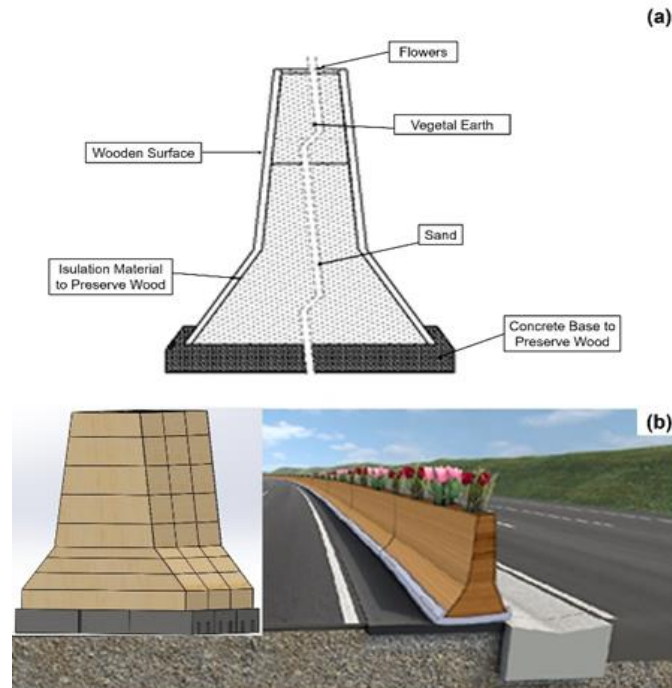

Figure 4.1. Parts of HBS (a), Appearance of HBS on road platform (b) [60].

The primary goal of the HBS design process is to absorb the impact energy and to keep the crashing vehicle on road platform. In this study, HBS are designed in concrete F-shape type barrier dimensions in order to make a comparison with an existing barrier type used in the application and thus to prove the efficiency. It is thought that different designs can be created after optimization.

HBS consist of four main elements: concrete base, metal profiles, sand and timber. The main body of HBS is formed by fixing metal profiles on the concrete base. Then the inner part of the barrier is filled with sandbags and the outer part is covered with timbers.

4.1.1. Wood

Hybrid barrier system is made primarily of wood, which guarantees its structural integrity and collision resistance. It provides HBS with an aesthetic appearance in addition to being a green and environmentally sustainable material. It has a number of benefits, including ease of workability, paint ability and varnish ability, high carbon stock capability, high strength relative to density, high shock suction, and heat and sound isolation [59-104].

The price of HBS changeable according to the sort of timber and obesity that will be utilized. Because of its easy availability and lower cost than other wood products, fir (*Abies nordmanniana* subsp. *Equi-trojani*) was chosen for HBS production. The fir timbers were mounted on HBS using a rubbed linking method. It is hoped that by doing so, visible fouling and malformations in the joints caused by shrinking and swelling cycles and the aging of fir timbers can be avoided. Fir timbers were prepared with a thickness of 20 mm, a length of 1250 mm, and a width of 100 mm as presented in Figure 4.2.

Fir timbers were mounted onto metal profiles by using 3.5 mm diameter screws.

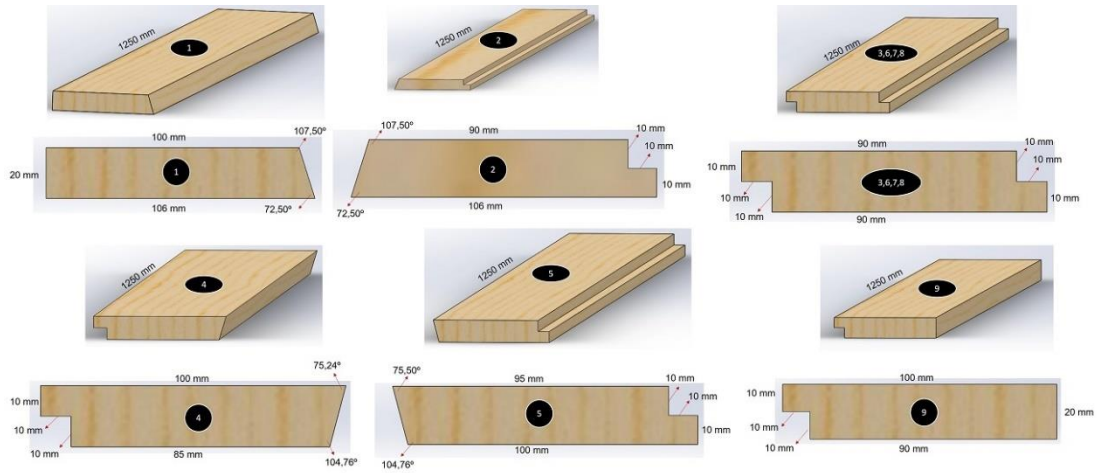

Figure 4.2. Dimensions of timber parts used on the walls of a Hybrid Barrier [60].

4.1.2. Concrete Base

Since HBS have a wooden frame, it is very significant to prevent the contact of wood with water in road platform in the long term, especially in rainy outdoor environments. For this reason, concrete bases whose dimensions are seen in Figure 4.3, were produced.

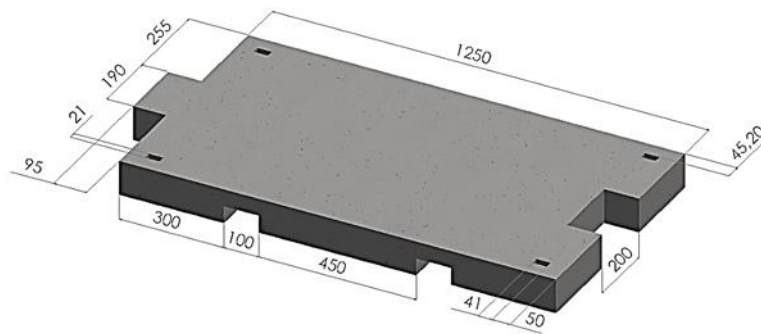

Figure 4.3. Concrete base dimensions (mm).

In addition, the connection of concrete bases with female and male parts will allow them to act together by helping energy transfer at the moment of a collision.

4.1.3. Steel Profiles

Steel profiles are the elements that form the basic shape of the barrier and allow the assembly of wooden timbers on. Wooden timbers are fixed horizontally to metal profiles via screws. Metal profiles are produced in the F-shape barrier form using 3 mm in thickness and 20x40 mm dimensions box profiles. They are mounted to the concrete base through the holes on the base. Connection points are fixed by welding. Two metal profiles were produced for each HBS. Their dimensions and an example are shown in Figure 4.4.a. It is planned to use three HBS together in experimental crashes. Accordingly, in addition to connecting adjacent barriers by means of male and female parts of the concrete bases, each metal profile is connected to each other from four different points with the help of rod and nut in metric 12 dimensions (Figure 4.4.b, and c). By this way, it is aimed to distribute the energy that will emerge at the moment of any collision, among the entire barrier line rather than a single point.

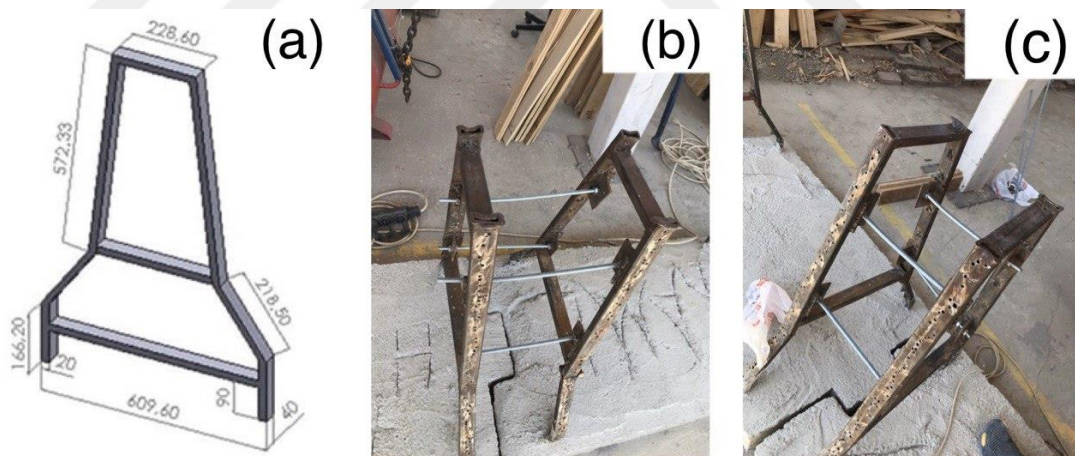

Figure 4.4. Metal profile dimensions used in the production of HBS (mm) (a), Connection points of RHBs (b and c).

4.1.4. Sand

It is a natural and granular material consisting of sand, crumbled rock and mineral particles. According to the TS 1900-1 standard, soil grains with diameters ranging from 0.075 mm to 2 mm are called sand. In practice, those up to 4mm in diameter are

called plaster sand, and up to 5mm are called concrete / screed sand. Unit volume weight can vary between 1,5 kN/m³ and 1,80 kN/m³ depending on the amount of void. It is dry or water-saturated, without cohesion, but has a certain cohesion in a certain water content. It is a soil material with elasto-plastic properties [105].

The grain size of the sand used in the Hybrid Barriers System is between 0.425 and 4.75 mm and unit volume weight is 1,60 kN/m³. In some countries, it is quite common to use the energy-absorbing effect of sand in protection structures such as fillings, retaining walls, galleries. It is known that the use of sand pillows in these protection structures is a positive solution against the high impact effect that occurs especially in rock falls from cut slopes on both sides of roads and railways. Sand can be used directly in contact with these protection structures or in geotextile cages called “sand cells”. Recently, studies have been carried out to examine the effects of these sand cells against shock impacts, and it is estimated that sand will be used especially in the form of a load cell in many protection structures due to its high energy-absorbing capability in the near future [106].

Hybrid Barriers sand was placed in gunnysacks as shown in Figure 4.5, to prevent new incident due to sand bestrow onto the road platform during any collision.



Figure 4.5. Placement of sand inside Hybrid Barrier.

A study in (2009) examined the punch effect of different shaped bullets on glass fiber reinforced plastic and 20% sand plates. They observed that the required ballistic

criteria were achieved in the plates containing sand and a remarkable energy absorption is attained. Other research in (2017) examined the effect of bullets of different shapes and weights by using sand in composite protective barriers, and stated that the amount of energy absorbed by sand provides the required ballistic limits, the amount of energy damping depends on the shape of the bullet and the compaction amount of the sand as well [107]. In (2012) the researcher emphasized the importance of reducing damage to armored vehicles and personnel in the explosion of a mine laid on a sandy ground. From this point of view, he examined the mechanical properties of sand with different water content under impact loads and stated that the water content affects the compaction properties of sand under impact loads [108].

Although sand has traditionally been used for military purposes (especially in trenches), little is known about the unique energy absorption capacity of this material. In a study by the National University of Singapore (NUS), the effect of the bullets of various shapes and masses against the silica sand block was examined and it was revealed that more than 85% of the energy of the bullets was absorbed by the sand. In the light of the results obtained, it is stated that sand can potentially be used as a cheaper, lighter and more environmentally friendly alternative to increase the protection level of critical systems as well as armored structures [109].

In Anatolian traditional buildings, 15-20 cm sand layer was laid and then the foundation was built. It was stated that the sand laid under the foundation does not transmit the ground water to the building, but it also has benefits in terms of dampening ground shaking in the earthquake [110]. A researcher in (2016) examined the effect of the sandy soil (sand cushion) used under the foundation against earthquake and revealed that the sand provides shock absorption and insulation. In (2014) another researcher examined the impact of the use of “sand pad” in a rock protection tunnel, which is a reinforced concrete protection structure, to prevent the impact of rock impacts on the slab of the tunnel [111]. The sand pad as showed in Figure 4.6, distributes the contact pressure and reduces the impulse acceleration and the impact time. As a result; He stated that the use of sand pads is an appropriate engineering approach to ensure the safety of important structures such as nuclear

facilities, fuel tanks, highways in mountain areas and rock protection tunnels along the cliffs.



Figure 4.6. Sand pad use in rock protection tunnel [111].

4.2. STEEL BARRIER

Steel guardrails have various designs that can be changed according to containment levels and local requirements. 3 mm in thickness S 235 JR class galvanized steel material specified in TS EN 10027-1 was used for the production of the guardrails used in this study. The guardrails and additional equipment were provided from General Directorate of Highways. The type of the rail is called as “A” type. The dimensions and shape are presented in Figure 4.7 and 4.8, yield, tensile strength and minimum elongation at break values of steel guardrail are illustrated in Table 4.1, and Table 4.2.

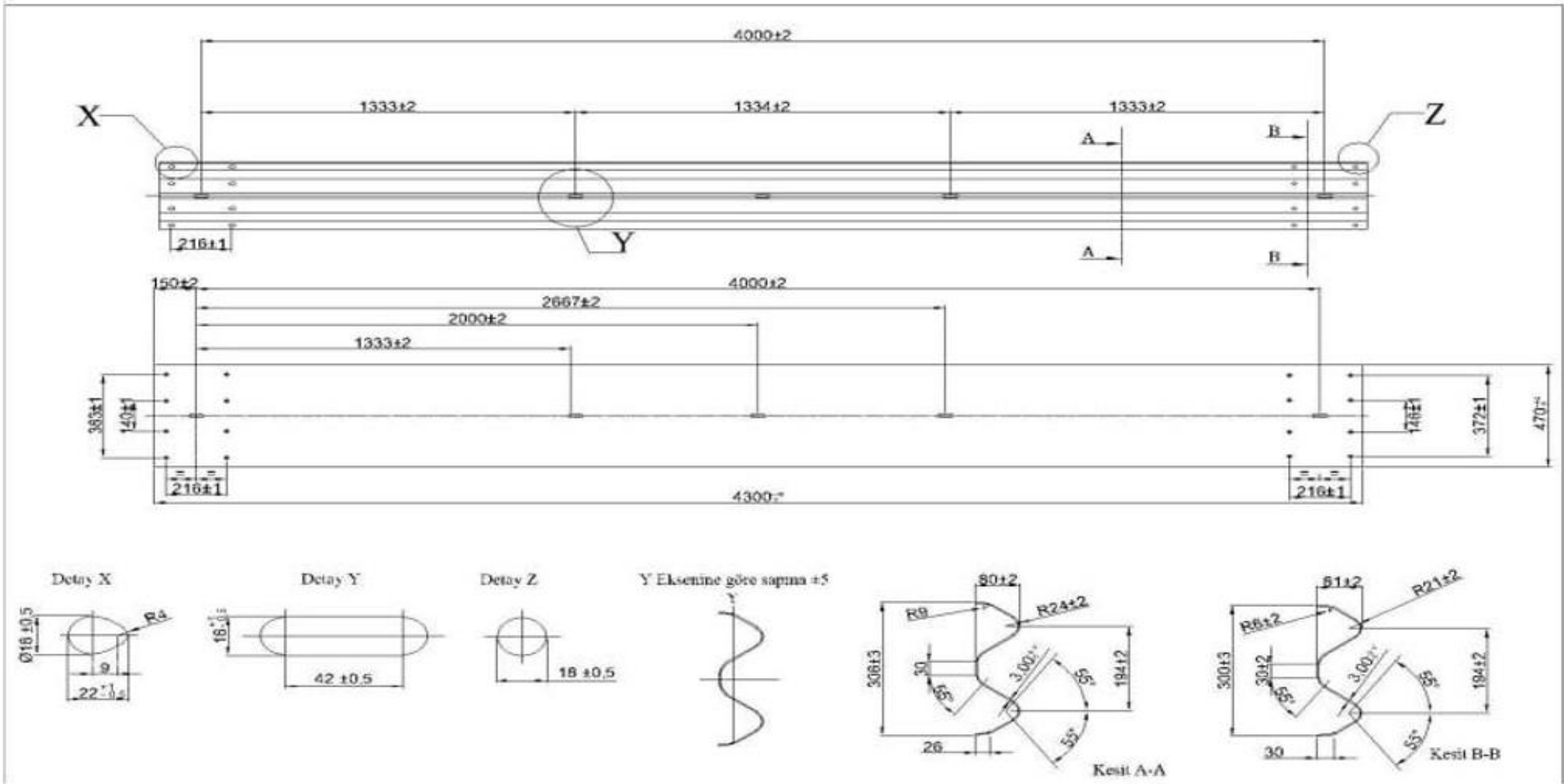

Figure 4.7. Dimensions of steel guardrail (mm).



Figure 4.8. Rail and posts.

Table 4.1. Yield and tensile strength values of steel guardrail.

Related Standart		Minimum yield strength (Mpa) Nominal thickness (mm)					Tensile strength (Mpa) Nominal thickness (mm)	
		≤ 16	> 16 ≤ 40	> 40 ≤ 63	> 63 ≤ 80	> 80 ≤ 100	< 3	≥ 3 ≤ 100
EN 10027-1 CR 10260	EN 10027-2	≤ 16	> 16 ≤ 40	> 40 ≤ 63	> 63 ≤ 80	> 80 ≤ 100	< 3	≥ 3 ≤ 100
S235JR	10.038	235	225	215	215	215	360-510	360-510

Table 4.2. Minimum elongation at break values of steel guardrail.

Related Standart		Minimum elongation at break (%)							
		Lo = 80 mm Nominal thickness (mm)					Lo = 5,65√So Nominal thickness (mm)		
EN 10027-1 CR 10260	EN 10027-2	≤ 1	> 1 ≤ 1,5	> 1,5 ≤ 2	> 2 ≤ 2,5	> 2,5 ≤ 3	> 3 ≤ 40	> 40 ≤ 63	> 63 ≤ 100
S235JR	10.038	17	18	19	20	21	26	25	24

4.3. CONCRETE BARRIER

In the literature, there are various concrete barriers in type and in dimensions [32,33,46,112-115]. Concrete barrier dimensions and shape used in this study are depicted in Figure 4.9 and 4.10, C 30/37 class concrete was used in the construction of the barriers. The concrete barriers were provided from General Directorate of Highways.



Figure 4.9. Concrete barrier shape

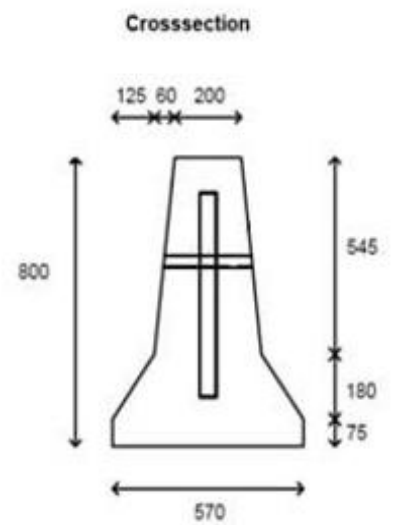
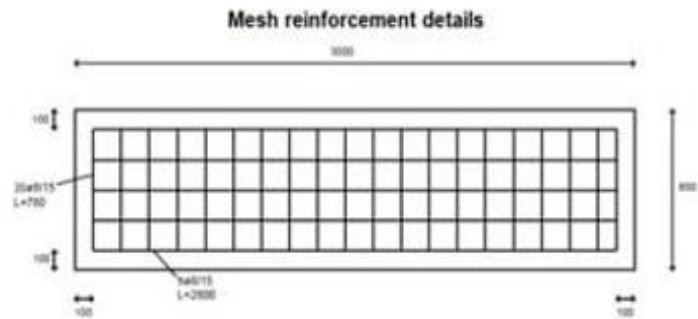
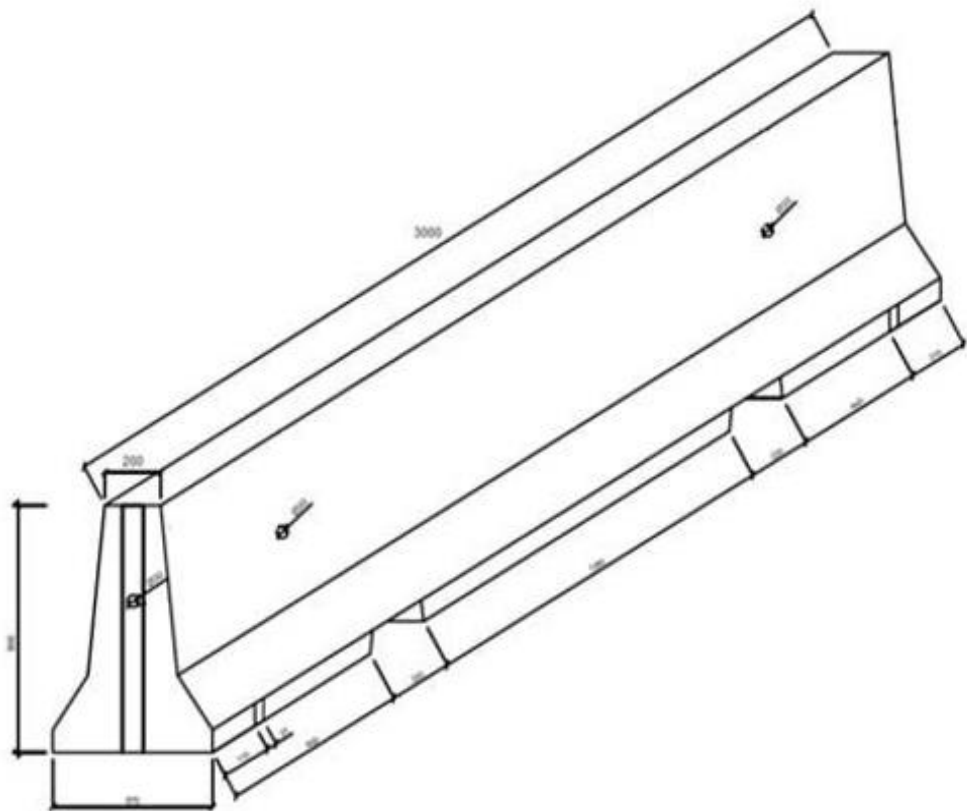

Figure 4.10. Dimensions of concrete barrier.

PART 5

THEORY AND METODOLOGY OF EXPERIMENTS

5.1. STANDARDS FOR ROAD RESTRAINT SYSTEMS

A roadway protection obstacle should meet minimal construction guides and design of matters. Based on European standard EN 1317 or the AASHTO (American Association of State Highway and Transportation Officials), road protection barriers must typically undergo crash tests. According to these guides, every road protection barrier should be crossing standardized impact tests as commanded in their acceptance mechanism [2]. The new technique is an invasion-pursuant saving-cost analyse that takes into account the winner prosecution level of roadway protection obstacles according to a difference betwixt the real-world collision statuses and the collision statuses of the full-scale impact tests conducted for standardization requirements in compliance with the European Commission [116].

The AASHTO Manual for Assessing Safety Hardware (MASH) and NCHRP 350 provide consistent standards for conducting full-scale collision tests for perpetual and short-term highway safety elements, as well as suggested assessment criteria for interpreting the results. EN 1317, NCHRP 350, and MASH are all efficiently designed rules that have aided in the evolution of roadside safety equipment. For the first three test levels, the three standards are near to each other in terms of impact kinetic energy, as illustrated in Figure 5.1. There is a smaller vehicle and a larger vehicle in EN 1317 and MASH. Vehicle masses for EN 1317 are 900 and 1,500 kg, for NCHRP 350 vehicles are 820 and 2,000 kg, and they have been extended in MASH to 1,100 and 2,270 kg, as shown in Figures 5.2, and 5.3, [117].

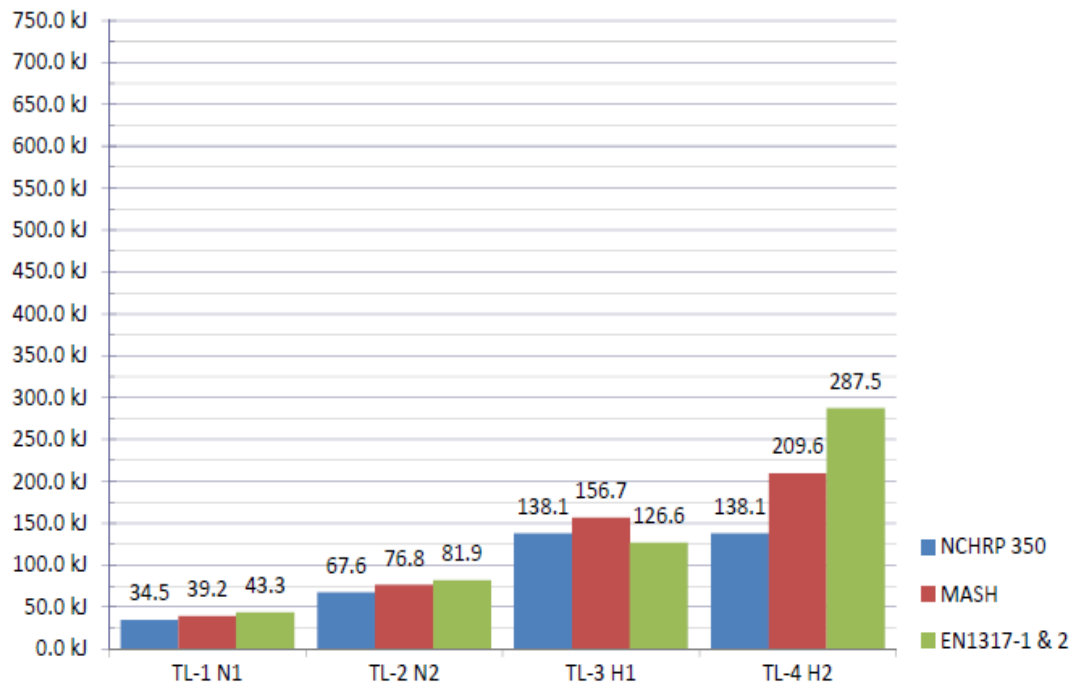

Figure 5.1. Nominal KE for longitudinal barriers for NCHRP 350, MASH, and EN 1317, utilizing vehicles with a mass of less than 16 tons [117].



(a)



(b)

(c)

Figure 5.2. Small car test vehicles: (a) EN 1317, (b) NCHRP 350, and (c) MASH [117].

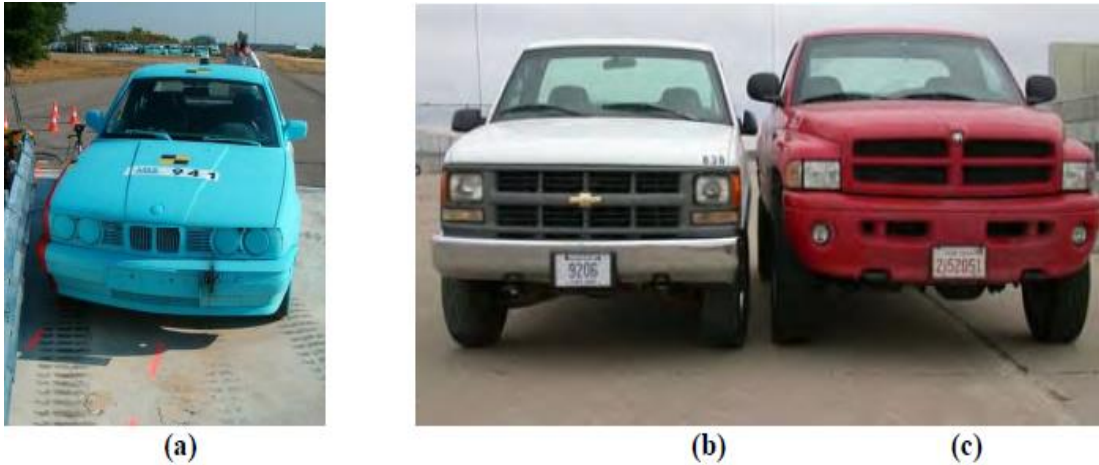

Figure 5.3. Larger test vehicles: (a) EN 1317, (b) NCHRP 350, and (c) MASH [117].

The United States success criteria, NCHRP 230 and the latest NCHRP 350, are referred to or straight used in most, guidelines for truck-mounted attenuators. The United Kingdom is the one country that has more than one performance standard. Two of them are from the United States, while the third is from the United Kingdom. The following is a quick rundown of the pertinent tests in the latest US guideline.

Main test level 2 include test 2-50 of an 820-kg car traveling at 70 kilometres per hour, in front collision with a shape vehicle placed in opposition to a fixed wall to stop the shape vehicle from rolling forward. Test 2-51: 2000-kg semi-heavy truck, 70 kilometres per hour, head-on collision, shape vehicle permitted to move head-way while prevented by spreading in second gear and handbrake engaged. Test 2-52: 2000-kg semi-heavy truck, 70 kilometres per hour, spacing one and a half the breadth of the striking vehicle, shape vehicle permitted to move head-way while restricted by spread in second gear and handbrake engaged. Test 2-53: 2000-kg semi-heavy truck, 70 kilometres per hour, 10-degree angle collision at the centre of truck mounted attenuators, shape vehicle permitted to roll head-way while restricted by spreading in second gear and handbrake in on place.

And test level 3 includes test 3-50: 820-kg car, travelling 100 kilometres per hour, in front crash with shape vehicle placed in opposition to a fixed wall to stop the shape vehicle from rolling head-way.

Test 3-51: 2000-kg semi heavy truck travelling at 100 kilometres per hour, in front collision with shape vehicle permitted to drift head-way while restricted by gearbox in second gear and handbrake engaged. Test 3-52: 2000-kg semi-heavy truck travelling at 100 kilometres per hour, spacing one and a half the breadth of the striking vehicle, shape vehicle permitted to move head-way while restricted by spread in second gear and handbrake engaged. Test 3-53: 2000-kg semi-heavy truck travelling at 100 kilometres per hour and 10-degree angle collision at the truck's centreline attenuators with the handbrake on and the spreading in second gear, the shape car is permitted to roll ahead.

In Korea, the full-size crash test is used to assess the efficacy of road safety measures. The severity index is the mean force from the kinematics of a vehicle collision, and road design speed is divided into five classes (50, 60, 80, 100, and 120 km/h) based on the road class. Trucks are tested at a 15-degree angle, while vehicles are tested at a 20-degree angle. Table 5.1, shows the vehicle's specifications under test. Flexible safety obstacles must enable a highest bending distance of 30 cm after a whole size collision test, while rigid safety obstacles must not let any type of plastic deformation in the major matters [74].

Table 5.1. Vehicle Specification Under Test Conditions.

	Type of Vehicle	Mass (kg)	Type of Facilities	Evaluation Item
LC	Car 1	900	Crash Cushion	All
NC	Car 2	1,000	Barrier	Occupants Safety
HC	Car 3	1,500	Crash Cushion	All
NT	Truck 1	14,000	Barrier	Intensity Capability
HT	Truck 2	25,000	Barrier	Intensity Capability
ST	Semi-trailer	36,000	Barrier	Intensity Capability

The new Australian standard (AS5100 2004) specifies separate low and regular performance levels for barriers, as well as new design and performance criteria for barriers. Low level of performance is for the operative containment of

lightweight vehicles with low traffic volumes on freeway, highways, and main roads, whereas regular performance levels are for the operative containment of cars, heavy services, and light to medium mass trucks on freeways, highways, and main roads, according to AS5100. Table 5.2, describes the low and regular performance levels [118].

Table 5.2. Required performance level.

Level	Vehicles	Design speed (km/h)	Impact angle (°)
Low	800-kg small car	70	20
	2,000-kg utility	70	25
Regular	800-kg small car	100	20
	2,000-kg utility	100	25
	8,000-kg truck	80	15

5.2. EN 1317 PERFORMANCE CRITERIA

The barriers that meet the international/national standards are allowed to be placed on the roads after the tests. Road barriers produced in different names and types need to pass some tests in compliance with EN 1317 standards. According to EN 1317, a real vehicle is subjected to physical crash test under the conditions specified in the standards (impact velocity, impact angle, etc.) by hitting the barrier whose performance is to be determined. Crash test criteria according to EN 1317 standard is given in Table 5.3.

Table 5.3. Crash test criteria according to EN 1317 standard.

Test Code	Vehicle type	Vehicle Weight (Kg)	Impact Rate (Km / h)	Impact Angle (degree)
TB11	Car	900	100	20
TB21	Car	1.300	80	8
TB22	Car	1.300	80	15
TB31	Car	1.500	80	20
TB32	Car	1.500	110	20
TB41	Truck	10.000	70	8
TB42	Truck	10.000	70	15
TB51	Bus	13.000	70	20
TB61	Truck	16.000	80	20
TB71	Truck	30.000	65	20
TB81	Truck	38.000	65	20

Evaluation criteria of collision results according to EN 1317-2 standard:

- 1) Structural competence; (I) The barrier must be able to hold the vehicle and not allow it to pass over or under. (II) The barrier must never lose contact with the vehicle by tearing or lying on the ground.
- 2) Impact loads to the driver and passengers; (I) Acceleration and skidding during collision should not be higher than standards. (II) The vehicle must not lose its stability in a collision.
- 3) The vehicle should have a low angle while leaving the barrier.

There are three major criteria of performance in the EN 1317 standard comprise: classes of containment, impact severity levels and the deformation of the barrier that comprise dynamic deflection and working width.

5.2.1. Classes of containment

Describes a barrier's ability to deflect a hitting vehicle. Lightest, normal, heavy, and very heavy are the four levels of containment defined by this standard. Test types that should be applied for the level of service to which the barrier systems belong are specified in Table 5.4, according to EN1317 standard. It is predicted that the hybrid barrier, will be in the normal service class, it will be used in historical,

touristic and natural roads where the traffic volume and speed will be low and heavy vehicle traffic will be low. Accordingly, it is aimed to perform the acceptance test numbered TB31, at the level of protection N1, which is one of the tests specified in this class.

Table 5.4. Acceptance tests of containment level according to EN 1317 standard.

Protection Level	Protection Level Code	Acceptance Test
Lightest Service	T1	TB21
	T2	TB22
	T3	TB21 + TB41
Normal Service	N1	TB31
	N2	TB11 + TB32
Heavy Service	H1	TB11 + TB42
	H2	TB11 + TB51
	H3	TB11 + TB61
Very Heavy Service	H4a	TB11 + TB71
	H4b	TB11 + TB81

According to the EN 1317 standard, the collision energy that must occur during the collision in the acceptance tests of the barriers is shown in Figure 5.4. In the acceptance test, TB31, which is planned to be applied in this study, an energy of 43 KJ must emerge during the collision.

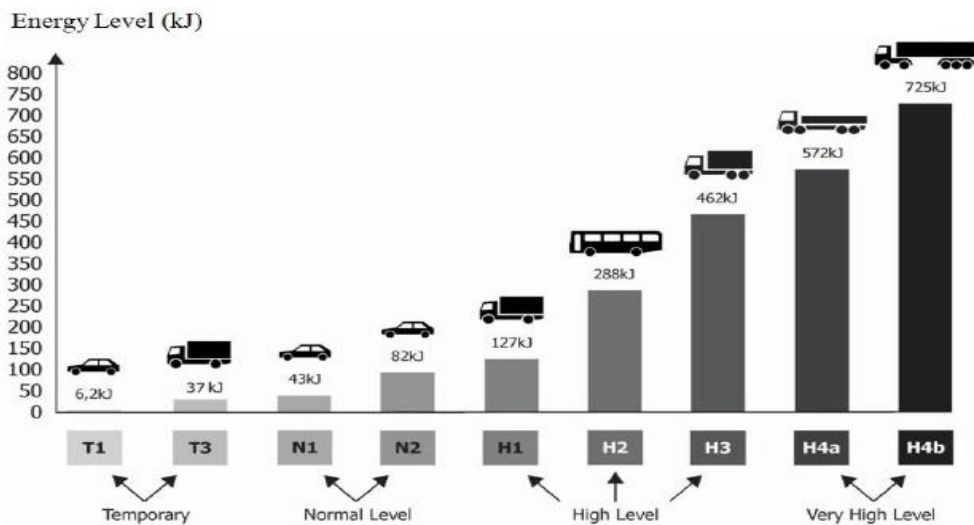

Figure 5.4. Collision energies emerging (Containment Level) in acceptance tests according to EN 1317 standard.

5.2.2. Working width

Working width (W) is defined as deflection occurring in the barrier system during the crash test. Working width classes can be seen in Table 5.5. Working width is defined as “the maximum lateral distance between any part of the barrier on the undeformed traffic side and the maximum dynamic position of any part of the barrier.” in EN 1317.

Table 5.5. Working width classes according to EN 1317.

Deformation Code	Working Width (m)
W1	$W \leq 0,6$
W2	$W \leq 0,8$
W3	$W \leq 1,0$
W4	$W \leq 1,3$
W5	$W \leq 1,7$
W6	$W \leq 2,1$
W7	$W \leq 2,5$
W8	$W \leq 3,5$

5.2.3. Acceleration Severity Index (ASI)

ASI (Acceleration Severity Index) parameter, known as impact intensity; It can be defined as a measure of the impact on the passengers in the vehicle and the impact severity of the vehicle passengers is assessed by acceleration severity index. When a car collides with a road restraint device, the (ASI) value shows how are unsafe the people inside the vehicle. This value should meet the criteria given in Table 5.6. When these values are exceeded, the risk increases in terms of passenger safety.

Table 5.6. EN 1317 European standard impact severity levels.

Impact Severity Level	Impact Severity Value
A	$ASI \leq 1,0$
B	$1,0 < ASI \leq 1,4$
C	$1,4 < ASI \leq 1,9$

The ASI values have been graded into three impact severity levels: A, B, and C, as shown in this table. Level A creates a safer level of severity for the occupants inside the vehicle than level B, and level B presents a safer level of severity than level C.

ASI is a time-dependent variable that can be determined using the Equation below.

$$ASI = \sqrt{\left(\frac{\bar{a}_x(t)}{\hat{a}_x}\right)^2 + \left(\frac{\bar{a}_y(t)}{\hat{a}_y}\right)^2 + \left(\frac{\bar{a}_z(t)}{\hat{a}_z}\right)^2} \quad (\text{eq.5.1})$$

\hat{a}_x , \hat{a}_y and \hat{a}_z are the limit value the components of acceleration along the body axes x, y and z

$$\hat{a}_x = 12, \quad \hat{a}_y = 9, \quad \hat{a}_z = 10$$

$\bar{a}_x(t)$, $\bar{a}_y(t)$ and $\bar{a}_z(t)$ are the acceleration elements obtained from the test by placing an accelerometer at the crash vehicle's center of gravity. Since a higher ASI value indicates a higher hazard for the passengers, the highest ASI value reached in a crash is used as a single measure of severity.

5.3. HYBRID BARRIER PENDULUM SYSTEM

According to EN 1317, barriers must achieve crash tests for their eligibility to use on roads. Although full-scale crash tests are a conventional mechanism to reveal the barrier performance, such tests are very costly in terms of the procurement of the required experiment area (creating a collision path, taking safety precautions, etc.), creating the crash mechanism (ensuring the vehicle hit at a certain speed and angle), and cost of each vehicle in repeated experiments. For this reason, in the literature, pendulum and similar systems have been used in the optimization phase instead of full-scale crash tests for the performance analysis of barrier systems [54,119-124].

There are some pendulum system studies in literature, in (1974) San Antonio, Texas southwest research institute with the forest products marketing laboratory cannibalized reinforced concrete pendulum method which showed in Figure 5.5, with the pendulum mass 1900 kg and dimensions (91 * 183 * 46) cm that adhered a 20 cm

steel tube in the fore, replete by concrete, the experiment was to appraise the effective behaviour of timbering and steel barrier posts, and crash rapidity of the pendulum system was 32.2 km per hour [125].

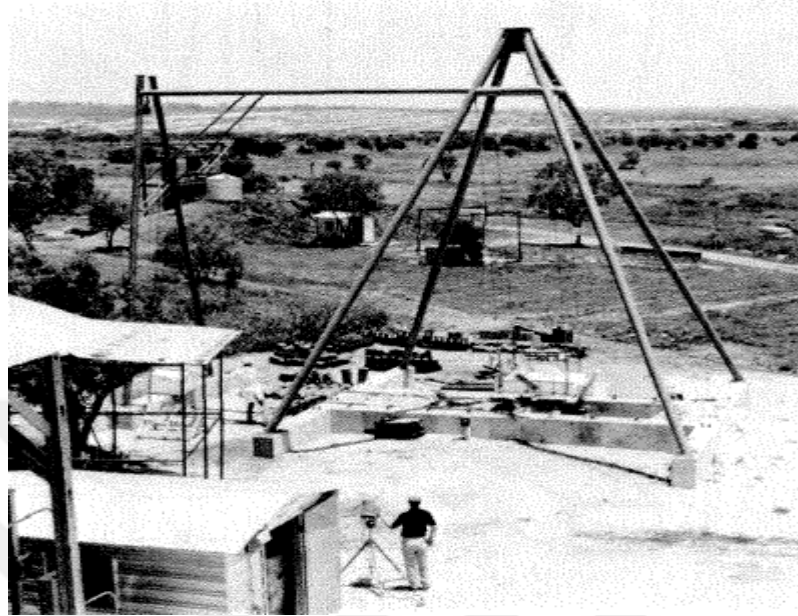

Figure 5.5. San Antonio, Texas southwest research institute pendulum [125].

A study in (1998) Used 820 kg pendulum with the accelerometer and high speed film camera to test strong post steel W-beam guardrail as illustrated its configuration in Figure 5.6. A pendulum test procedure has been developed to perform preliminary screening and evaluation of prototype guardrails prior to conducting full-scale crash testing. The velocity of the pendulum was 9.25, 20, 30 and 35 km/h respectively. The result showed that the displacement at the speed 9.25 km/h was approximately 0.15 m after 0.12 s, at the speed 20 km/h was 0.8 m after 0.25 s. In the test of 30 km/h the guardrail system was able to bring the pendulum to rest, however the initial velocity was almost large enough to cause the pendulum mass to jump over the rail at the end of its trajectory. This was due to the large deflection of the system caused by bending and twisting of the posts and the natural tendency of the pendulum to rise as it passes through the lowest point of its trajectory. And in the physical test pendulum come to rest at a displacement of 1.25 m after 0.22 s. Finally, in the 35 km/h test the guardrail system failed to bring the pendulum to rest in all three repeats of the physical test, so the system failed due to either bolt shear failure of failure of the block [126].

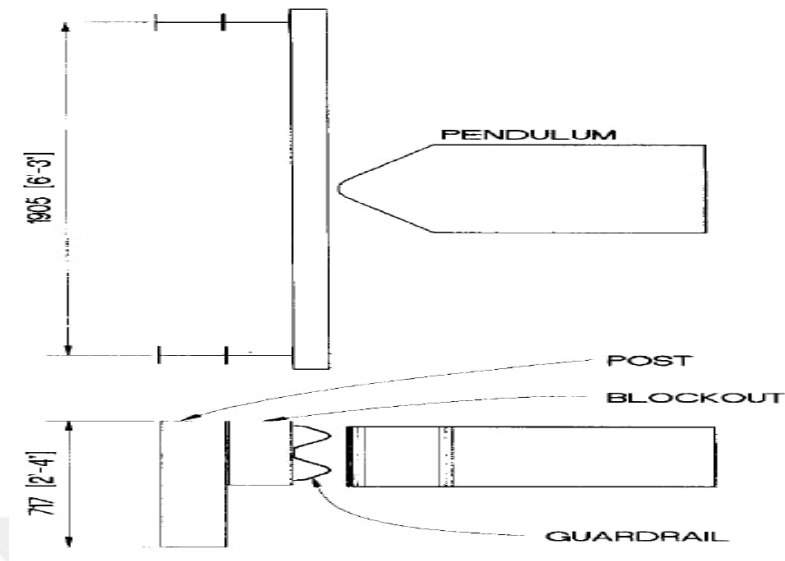

Figure 5.6. Configuration of 820 kg pendulum used in 1998 [126].

In (2010) other experiment used a foil pendulum as showed its shape and details in Figure 5.7, the mass of pendulum is 2000-kg that contains of 2 stiff posts at the sides of hanging pendulum mass and the semi diameter of impactor midpoint profile was 15.2 cm based on quantifying of 2006 Chevrolet 1500 pickup to testing steel beam guardrail with the strong post and wood block out. Because of the close nearness of the stiff posts one of two edges of the pendulum, end fixture designed by using 2 and 3 typical cable drop anchors and 91.4 cm sort of the measure 2 m to fix w-beam terminals. In every experiment 2 accelerometers are used which placed at the back of the pendulum with 4 high speed cameras. The experiment coordinated at the impact speed of 32.2 km/h and 28.2 km/h. The 32.2 km/h impact rapidity was initially selected to approach the sideways forces that would outcome from a 2000 kg test automobile impacting at 100 kilometres per hour and 20 degrees. The consequence showed that in the all three essential experiments, the uninjured obstacle part indicated sufficient crash showing by containing the weight of pendulum, and appropriate tie of the w-beam guardrail segment to the stiff post on one or the other extremity of the pendulum was imparted by the wire end fixture design [127].

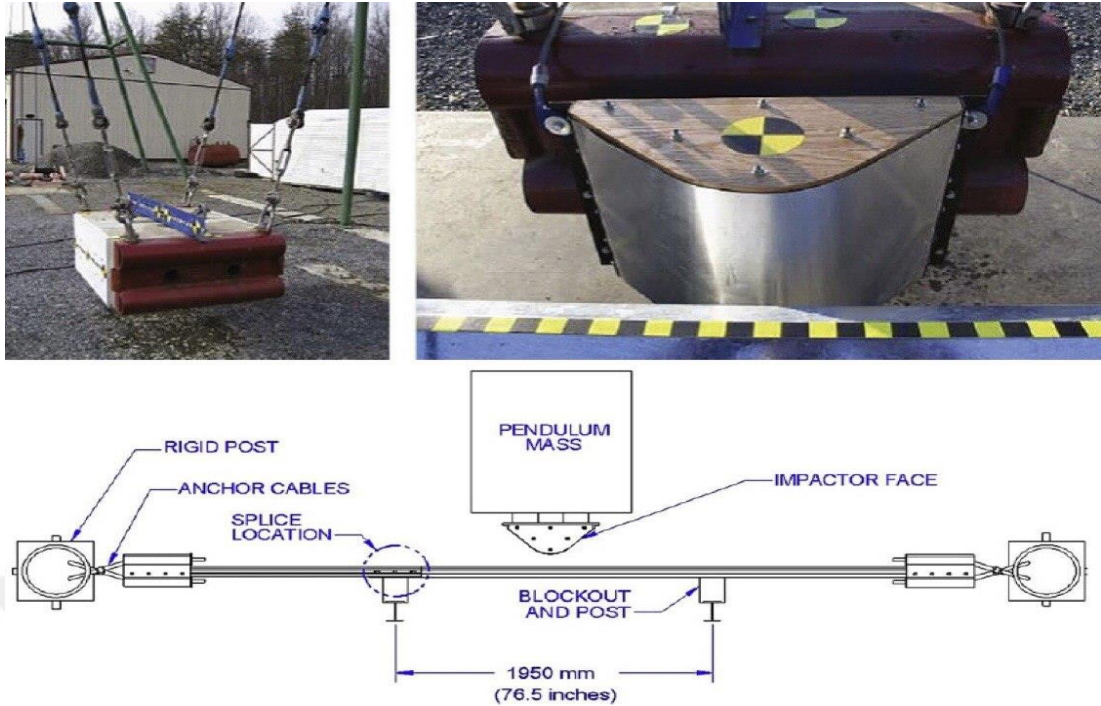

Figure 5.7. Details of 2000-kg pendulum used in 2010 [127].

In another study 2000-kg rigid pendulum was used in a series test which performed at Federal Highway Administration (FHWA), Federal Outdoor Impact Laboratory (FOIL) to evaluate the performance of wood post, soil materials density and the terminal energy absorption as shown the pendulum in Figure 5.8. The dimensions of wood post were 0.15 m in width, 0.2 m in depth and 1 m in length. As other pendulum systems in this test accelerometer and high speed digital cameras were used. The crash speed was 24 km/h to the timber post testing and 16 km/h to the soil materials performed test. The main aim of these tests was to verification the computer simulation results [128].



Figure 5.8. Configuration of 2000-kg pendulum used at FHWA and FOIL [128].

The stiff body, pendulum hammer, and ties on which the pendulum hammer is hanging make up the hybrid barrier pendulum system. The pendulum hammer is raised to a certain height before being let fall freely. As a result, by hitting the obstacle at the evenly velocity each time, the evenly amount of energy can be delivered. In addition to being less expensive than real-time crash simulations, the pendulum device is more appropriate for workplace safety and realistic. Figure 5.9, depicts the hybrid barrier pendulum device.



Figure 5.9. Experimental pendulum crash system.

The outer walls of the pendulum rammer are made of a 10 mm thick steel sheet and the inner part is filled with iron powder and weighs 1500 kg to represent the TB31 vehicle. The pendulum rammer is suspended on the mainframe with a total of 4 chains, 2 on each side. In this way, it is aimed to keep the weight in the axis during the collision and to prevent lateral oscillations.

The total energy of the pendulum in the number 1 position is calculated according to the potential energy equation in Formula 5.2.

$$E_p = m \cdot g \cdot h \quad (\text{eq.5.2})$$

In this formula, E_p : total potential energy (J), m : weight of the rammer (kg), g : gravitational acceleration (m/s^2), h : height of the rammer (m).

According to the law of conservation of energy, the pendulum hammer loses its height, and its potential energy just before colliding with the barrier completely converts into kinetic energy thus, the potential energy of the pendulum rammer at position 1 and kinetic energy at position 2 will be equal. From this point of view, the amount of energy generated on the barriers during the collision is indicated in the EN 1317 containment levels. For the N1 containment level, this energy is specified as 43 kJ. According to Formula 2, it was calculated that the freefall height of the pendulum rammer should be 2.93 m to attain this energy level.

In the acceptance test number TB31, which is planned to be applied in this study, an energy of 43 kJ should be released during the collision. In the crash test no. TB31, a representative image of which is shown in Figure 5.10, a 1500 kg vehicle crashes into the barrier at a speed of 80 km/h and an angle of 20° . If the F force is defined as the force components of the vehicle striking the barrier, F_x and F_y , the F_y component represents the force falling on the barrier as a result of the collision.

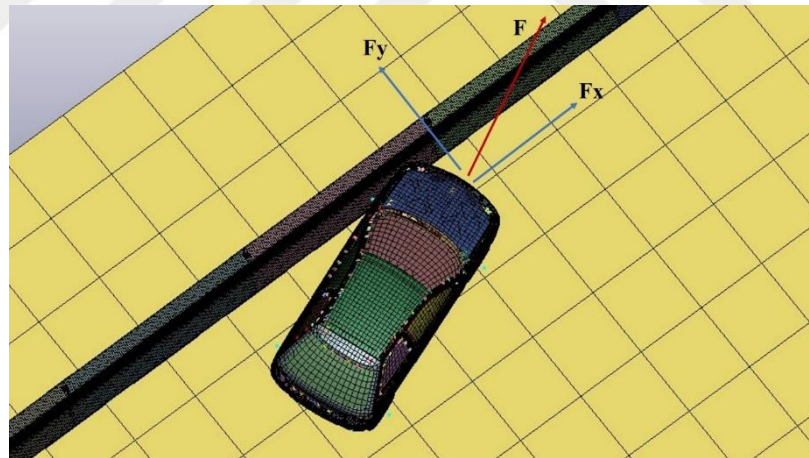

Figure 5.10. Crash test example TB31.

The total energy generated in the F_y direction (component falling on the barrier) should be 43 kJ. This energy is calculated according to the equation in Equation 5.3.

$$E = \frac{1}{2} \times m \times \left(\frac{v}{3,6} \times \sin 20 \right)^2 \quad (\text{eq.5.3})$$

That;

E: The amount of energy (J) formed in the Fy direction

m: Vehicle weight (kg)

V: Vehicle speed (km/h).

In summary, this study was based on TB31 acceptance test and N1 normal containment level test criteria. Accordingly, the pendulum rammer weighing 1500 kg was lifted with the help of a crane mounted on the pendulum system frame so that its centre of gravity was 1.73 m. Repeated experiments were carried out by lifting the pendulum rammer to the same height for each experiment and energy of 25.5 kJ was created on the barrier every time.

There is not any information in EN 1317 standard regarding the height of the pendulum rammer from the ground level at the crash point. Within the scope of this study, the average of N1 containment level vehicle types were analysed, and additionally, in the light of literature studies, this value was predicted to be 50 cm then the rammer was hung on the pendulum system frame.

5.4. FINITE ELEMENT ANALYSIS

In guardrail analysis and innovation, numerical analysis using a computer simulation software developed in the early 1960s. Several simulation programs, including HVOSM, Barrier VII, GUARD, DYNA3D and MADYMO, have been established [95]. Although its utility in recognizing the impact process, measuring safety efficiency and reducing the quantity of impact tests, the use of simulations has advanced from designing crash tests to endorsing hardware design decisions and providing guidelines for road-side hardware installation, usually full-scale impact testing is wasting time and expensive, considering that the same test should be repeated for different types of vehicles, this method seems to be quite costly. Therefore, especially in recent years, many studies have been carried out on

simulating crash tests in virtual environment by using 'Finite Elements Method' with computers. Thanks to virtual collision analysis using computers, it is much more economical to examine barrier behaviors, and more importantly, researchers can access more information much faster than real-time crash tests [129]. Particularly in the evaluation of big design test matrix, so the use of numerical simulation can reduce costs and play a role in saving time. With the fast advancement of technology and computing strategies, it is now feasible to use commercial software programs such as LS-DYNA to conduct full-scale numerical simulation of vehicle impacts [64,130].

Today, with the development of technology, many commercial software such as ANSYS, NASTRAN, LS-DYNA, ABAQUS, PATRAN are used for the analysis process of complex problems. These package programs have facilitated the correct and effective solution of the non-linear and dynamic analyzes that occur from complex designs in a short time [131]. Thanks to commercial software, crash simulations are analyzed many times without using vehicle and human prototypes in a virtual environment, and the correct result is achieved quickly by saving both economy and time [132].

Many studies have been conducted to measure the performance of barrier systems during vehicle collisions. These studies can be carried out using real collision experiments as well as using virtual collision experiments in which collisions are simulated in computer environment. To reduce the development and testing costs of new safety barrier designs, it is recommended to use computational accident simulations in the early assessment of safety barrier behavior under the influence of the test tool. In this way, impact severity parameters and barrier deformation can be estimated before a real crash test and possible design changes can be easily evaluated [130].

It is not appropriate to evaluate each crash scenario using full-scale crash tests under difficult research conditions, considering today's world economy. Recently, crash testing in simulation environment is more preferred than real-time tests. The CEN / TR 16303 standard contains guidelines for numerical simulations and is highly

efficient at this point [133]. In order to test the conditions in EN 1317 standard in simulation environment, procedures in EN / 16303 standard should be applied.

In the 1960s, with the introduction of the numerical simulation of vehicle accidents for the New York Public works Department, Cornell Aeronautical Laboratories developed early finite element analysis of roadside protection. Since then, a number of projects for the creation of particular target numerical simulation codes for the study of roadside barriers have been carried out. In 90s of last century, three programs to develop advanced capabilities for computational models of roadside hardware accidents were funded by the United State Federal Highway Administration (FHWA). The consequence of these works was that the DYNA3D and LS-DYNA3D general-purpose non - linear finite element programs became the new guideline for the simulation of these crashes.

The first effort to use LS-DYNA effectively for roadside hardware testing was the 1991 GM Saturn model. The model was used to simulate a fundamental crash with validate for slip-base luminaires, a solid wall, and support for U-post signs, illustrating the viability of using the study of nonlinear finite elements. For fundamental crash with barrier terminals and redirection impacts with safety barriers and bridge railings, another simple model of a 0.82-ton small inhabitant vehicle for FHWA was built. A 1994 Chevrolet C-2500 truck and a small 800 kg vehicle, a 2000 kg utility small truck and an 8000 kg trailer are some current vehicle models produced. In this research, the finite element database of the tiny car model and usefulness model from the United State National Crash Analysis Center (NCAC) and the enhanced vehicle model in comparison are used to examine the truck crashing into the guardrail of three-rail steel [89].

In this study only experimental results were obtained. The experimental results will be a basis for the validation of FEM simulations and by this way virtual full scale tests will be carried out for future studies.

5.5. DATA PROCUREMENT

In order to evaluate crash performance of the hybrid barrier system and comparing with concrete barrier and steel guardrail in accordance with EN 1317, the ASI and working width (W) as illustrated above from equations and Table should be calculated. For this purpose, two cameras were fixed which the standard is indicated their place so that one was recording from the side view (Casio Exilim Pro EX-F1) and the other was recording from the top view (GoPro Hero 5). Although, accelerometer device (PCB Piezotronics-350A43) was mounted (PCB Piezotronics-350A43) at the center of gravity on the pendulum hammer as shown in Figure 5.11.

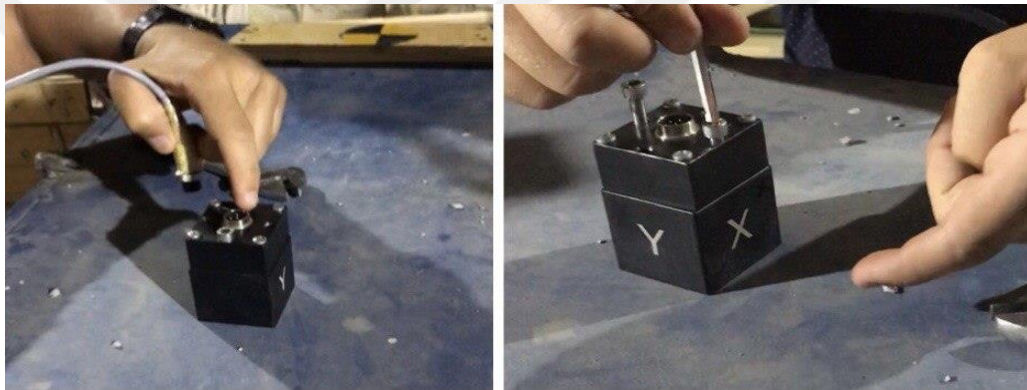

Figure 5.11. The accelerometer device.

In addition, to demonstrate the observes that obtained from the cameras 7.5 cm in diameter vector illustrators were pointed at specify location of pendulum rammer as shown in Figure 5.12. Additionally, as illustrated in Figure 5.13, a yellow line was drawn on the ground to fix the starting point of each experiment for hybrid and concrete barriers. By "Image J" program working width is also measured which camera videos recorded.



Figure 5.12. 7.5 cm in diameter vector illustrators.



Figure 5.13. yellow line to fix the starting point of each experiment.

5.6. APPLICATION OF EXPERIMENTS

We decided to test three types of roadside barrier, hybrid barrier system on the one hand, steel and concrete barrier on the other hand, and the configurations was tested several times to assess the repeatability of the process by using a pendulum. Within the scope of the study, three successful repetitions carried out to hybrid barrier, one successful repetitions to concrete barrier and one successful experiment to steel guardrail due to economic and time constraints and then average values were considered.

5.6.1. Hybrid Barrier

According to EN 1317-2, the optimal test length was determined, and three Hybrid Barriers were fastened together for each test on the pendulum system's crash point. To imitate real-world conditions, no ground contact was achieved, as seen in Figure 5.14.



Figure 5.14. Optimum sufficient test length of hybrid barrier.

5.6.2. Concrete Barrier

To imitate identical length conditions with a hybrid barrier, only one concrete barrier was built to the crash point of the pendulum system with the use of a backhoe and a crane, and no ground contact was established to replicate real situations, as illustrated in Figures 5.15 and 5.16. The pendulum's rammer slammed into the concrete barrier in the middle.



Figure 5.15. The installation process of the concrete barriers



Figure 5.16. Concrete barrier installation to the crash point of pendulum system.

5.6.3 Steel Barrier

Before application of the guardrail, concrete pavement on the surface was cut with a concrete cutting machine as shown in Figure 5.17.



Figure 5.17. Concrete cutting machine.

The posts are then pounded by a guardrail post driver until the tops of the rails are 750 mm above ground level, and the earth is subsequently filled with soil and compacted (Figure 5.18, and 5.19). Three posts were pounded at a distance of 2000 mm from one another, and the pendulum's rammer slammed into the rail exactly where the middle post is located.



Figure 5.18. guardrail post driving machine.



Figure 5.19. W- beam steel barrier after installation process.

PART 6

RESULTS

All the barriers (Hybrid, Concrete and W-beam steel barrier) were tested by the pendulum crash system through hitting the middle point. Figure 6.1, 6.2 and 6.3, illustrates the front view, back view and side view of the barriers after crashing with the pendulum, and the data observations of working width (W) and acceleration severity index (ASI) were obtained crash test are presented in Table 6.1, and 6.2.



Figure 6.1. Deformation shape of hybrid barrier after crashing with pendulum.



Figure 6.2. Deformation shape of concrete barrier after crashing with pendulum.

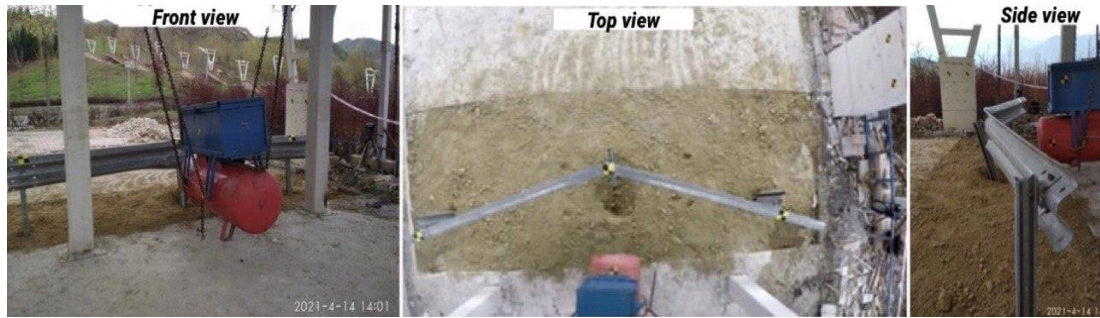

Figure 6.3. Deformation shape of w-beam guardrail after crashing with pendulum.

Table 6.1. Working width results of barriers according to pendulum crash test.

Barrier Type	Working width (m)		Working width Class
	25.5 KJ	43 KJ	43 KJ
Hybrid Barrier	0.87	1.46	W5
Concrete Barrier	1.25	2.10	W6
W-Beam Steel Guardrail	0.81	1.36	W5

Table 6.1, shows the suggested working width ranges based on the test results. The working width for various types of barriers varied between W5 and W6 based on findings from the pendulum impact test collected from camera images, the results showed the same working width class for the hybrid barrier and steel guardrail but a little difference for concrete barrier meanwhile all findings dropped within reasonable limits of EN 1317.

Table 6.2. ASI classes of barriers according to pendulum crash tests.

Barrier Type	Deceleration of 25.5 KJ (m/s²)	ASI value of 25.5 KJ	Deceleration of 43 KJ (m/s²)	ASI value of 43 KJ	ASI class of 43 KJ
Hybrid	5.36	0.45	9.78	0.82	A
Concrete	19.16	1.60	30.66	2.55	Fail
W-Beam	5.28	0.44	8.90	0.74	A

Table 6.2, displays the deceleration value of 25.5 KJ, which was measured from pendulum clash testing by mounting an accelerometer at the center of the pendulum hammer, and was transformed to an acceleration severity index (ASI) of 25.5 KJ by using the formula (eq.5.1). Following that, two deceleration values of 25.5 KJ and ASI of 25.5 KJ were transformed to deceleration of 43 KJ and ASI of 43 KJ, to acceptance by EN 1317 guideline. According to the results both hybrid barrier and steel guardrail have same class of ASI (W5) and their passenger risk factors are within the limits specified in EN 1317, but the ASI approval test conditions in EN 1317 were not met by the concrete barrier.

PART 7

DISCUSSION

Researchers have advanced various barrier sorts to resist high collision loads that can occur throughout a crash, but the aesthetic side of barriers is overlooked due to protection and structural demands. Designers were often unaware of the impact of these structures on the environment, particularly in natural and historic areas. As a result, a barrier must be built to satisfy both aesthetic and safety requirements, and it is thought that a hybrid barrier would fill this void.

According to the literature, the most significant drawback of timber barriers is their high cost. By combining wood and sand, this study enables the use of less expensive and higher collision efficiency barriers than other timber barriers. Since the topic of this study is interdisciplinary and includes experts from various fields (forest/timber specialist, soil specialist, transportation specialist), it is expected that this research will add scientific value.

The enhance studies that will be performed as part of this study will serve as a foundation for the next step, which will be the implementation of large-scale full-time impact tests and standardization experiments in one of the globally certified test centers.

The results and conclusions were drawn after reviewing the study's findings, which revealed that the hybrid barrier and steel guardrail had the same working width class, but the concrete barrier had a slight difference; however, both findings fell within EN 1317's acceptable limits, as shown in Table 6.1, in the results part.

In addition, as seen in Table 6.2, in the results part, the ASI values of the hybrid barrier and the W-beam guardrail are nearly identical (0.82 and 0.74) that are

categorized to A class, while the ASI value of concrete barrier is so far from W-beam and hybrid barrier that it cannot be categorized to ASI class because its value (2.55) was not in the approval criterion in terms of ASI as per EN 1317 because the highest value of ASI equals (1.9). Eventually, the ASI values of the hybrid barrier system and the W-beam guardrail collected from impact tests are appropriate, whereas the ASI values of the concrete barrier are inappropriate within the ASI limit classes set by EN 1317.

As a result, we realized that the hybrid barrier system better and have the ability to use programmed lateral deflection to contain and redirect the vehicle especially in historical areas than both types (Concrete barrier and W-beam guardrail) in terms of performance and impact on the structure of cars and the safety of the traveller in the car as shown in the figures of Hybrid barrier collisions there are restrictive amount of damaged or cracked timber parts and there are no bestrow of sand also no buckling in the backside of the hybrid barrier, and this points validated that the potential energy during vehicle hitting did not transfer to the occupants inside the vehicle. But as it is known in previous studies that during the car collision with concrete roadside barrier all the energy is swamped by the car due to high severity index of concrete barrier and causes a lot of damage to the cars and passengers besides steel guardrail which as a knife, it endangers the lives of the passengers during the collision and safely endangers the lives of motorists, unlike the hybrid barrier system that we were able to reduce those risks to a significant extent while designing, also by using renewable materials (sand and wood), it is also aimed to contribute diminishing global warming and environmental pollution and due to the upper plant it expected to prevent oncoming light shining of opposite direction vehicles. The experimental test has proved which have a good performance of working width and acceleration severity index (ASI), and can be used in places where have a low traffic volume in the hope that it can reduce the damage of traffic accidents and to be a good alternative to other types of road restraint system.

REFERENCES

1. Butans, Gross, K. A., Gridnevs, A., and Karzubova, E., "Road safety barriers, the need and influence on road traffic accidents", **IOP Conference Series: Materials Science And Engineering**, 96 (1): (2015).
2. Teng, T., Liang, C., and Tran, T., "Development and validation of a finite element model for road safety barrier impact tests", (11): (2016).
3. National Highway Transportation Safety Administration homepage (NHTSA) (2003) Facts sheets, NHTSA, Washington DC, www.nhtsa.gov
4. Original, A., "Road traffic accidents : Global Burden of Disease study , Brazil and federated units , 1990 and 2015", (25000192049): 157–170 (2017).
5. Qu, Y. I., Lin, Z., Li, H., and Zhang, X., "Feature Recognition of Urban Road Traffic Accidents Based on GA- XGBoost in the Context of Big Data", XX: (2019).
6. WHO, "Global status report on road safety 2018", **World Health Organization**, Geneva (2018).
7. Manyara, C. G., "Combating Road Traffic Accidents in Kenya: A Challenge for an Emerging Economy", *Kenya After 50*, 101–122 (2016).
8. Rezaei, S., Arab, M., Karami Matin, B., and Akbari Sari, A., "Extent, consequences and economic burden of road traffic crashes in Iran", ***Journal Of Injury And Violence Research***, 6 (2): 57–63 (2014).
9. Sugiyanto, G., "The cost of traffic accident and equivalent (case study in Indonesia)", ***ARPJ Journal Of Engineering And Applied Sciences***, 12 (2): 389–397 (2017).

10. Petrov, A., "Model of Calculation and Subsequent Assessment of the Economic Losses of the Ural Federal District Subjects in Case of Death and Injury in Road Traffic Accidents", *Transportation Research Procedia*, 20 (September 2016): 493–498 (2017).
11. OZEN, E., GENÇ, E., and KAYA, Z., "Estimation of the Costs of Traffic Accidents in Turkey: an Evaluation in Terms of the Insurance and Financial System", *Journal Of Yaşar University*, 9 (33): 5649 (2014).
12. Albayati, A. H. K. and Latief, R. H., "Statistical Analysis of Mortality and Morbidity Due To Traffic Accidents in Iraq", *Journal Of Engineering*, 24 (1): 20–40 (2018).
13. Grzebieta, R. H., Zou, R., Jiang, T., and Carey, A., "Roadside hazard and barrier crashworthiness issues confronting vehicle and barrier manufactures and government regulators", **Proc. 19th International Technical Conference On The Enhanced Safety Of Vehicles, Washington, USA**, 15 (2005).
14. Wu, W. and Thomson, R., "Compatibility between passenger vehicles and road barriers during oblique collisions", *International Journal Of Crashworthiness*, 9 (3): 245–253 (2004).
15. Margiotta, G., Calvisi, G., Carnevali, E., Bacci, M., and Gabbrielli, M., "A fatal crash against guardrail. Report of a case and considerations about safety of roadway barriers in Italy", *Romanian Journal Of Legal Medicine*, 23 (1): 5–8 (2015).
16. Jameel, A. K. and Evdorides, H., "Review of the Road Crash Data Availability in Iraq", 13 (9): 521–526 (2019).
17. Profile, S. E. E., "Road traffic accidents in Iraq: A review of evidence-", *International Journal For Traffic And Transport Engineering (IJTTE)*, 7 (April 2017): (2018).
18. Tunç, A., "Yol Güvenlik Mühendisliği ve Uygulamaları", Asil Yayın Dağıtım, ANKARA (2004).
19. Cerema, "Les Accidents Mortels contre Obstacles", *Centre D'etudes Techniques de L'equipement Normandie Centre*, Fransa (1995).
20. KGM, "Karayolları Genel Müdürlüğü Sorumluluğundaki Yol Ağında Meydana Gelen Trafik Kazalarına Ait Özet Bilgiler", *Karayolları Genel Müdürlüğü*, ANKARA (2016).
21. KGM, "Karayolu Tasarım Raporu: Ek:3 Yol Kenarı Alanları ve Otokorkuluklar ile ilgili olarak Önerilen Tasarım Esasları", *Karayolları Genel Müdürlüğü*, ANKARA (2000).
22. Wright, P. H., "Highway Engineering", John Wiley, New York (1996).

23. KGM, "Karayolu Tasarım El Kitabı", *Karayolları Genel Müdürlüğü*, ANKARA (2005).
24. Ray, M. H., "The Use of Finite Element Analysis in Roadside Hardware Design", *International Journal of Crashworthiness*, 2(4):333-348 (1997).
25. ETSC, "Forgiving Roadside", *European Transport Safety Council*, BRÜKSEL (1998).
26. Karataş, F., "Ağır Vasıta Çarpmalarına Dayanıklı Geçiş Otokorkulukları: Bir Çelikten – Betona Geçiş Otokorkuluğu Tasarımı ve Analizi", *Hatay Mustafa Kemal Üniversitesi, Yüksek Lisans Tezi*, HATAY (2010).
27. Pilia, F., Maltinti, F., and Annuziata, F., "Preliminary Results on a New Safety Road Barrier Made Completely of Wood", *Environmental Semeiotics*, 5(2):11-23 (2012).
28. Teng, T.L., Liang, C.C., Hsu, C.Y., Shih, C.J. and Tran, T.T., "Impact Performance of W-Beam Guardrail Supported by Different Shaped Posts", *International Journal of Mechanical Engineering and Applications*, 4(2):59-64 (2016).
29. Elvik, R., Høy, A., Vaa, T. and Sørensen, M., "The Handbook of Road Safety Measures", Emerald Group Publishing Limited, İngiltere, Kuzey Amerika, Japonya, Hindistan, Malezya, Çin (2009).
30. Gabler, H.C., Gabauer, D.J., "Opportunities for reduction of fatalities in vehicle-guardrail collisions", *Annu Proc Assoc Adv Automot Med*, 51: 31-48 (2007).
31. Soltani, M., Moghaddam, T. B., Karim, M. R., and Ramli Sulong, N. H., "Analysis of developed transition road safety barrier systems", *Accident Analysis and Prevention*, 59: 240–252 (2013).
32. HOU, S., ZHENG, Y., XIE, J., and HAN, X., "Optimization Design of Nj Shaped Guardrail Based on Collision Safety Consideration", *International Journal of Computational Methods*, 11 (06): 1350083 (2014).
33. Amato, G., O'Brien, F., Ghosh, B., and Simms, C. K., "Multibody modelling of a TB31 and a TB32 crash test with vertical portable concrete barriers: Model verification and sensitivity analysis", *Proceedings Of The Institution Of Mechanical Engineers, Part K: Journal Of Multi-Body Dynamics*, 227 (3): 245–260 (2013).
34. Kuebler, J., "Improvement of safety on German bridges- newsafety barriers to avoid a fall down of heavy lorries ", *young researches seminar of FERHL, ECTRI, PERSI*, (2007).
35. Atahan, A. O., "Vehicle crash test simulation of roadside hardware using LS-DYNA: A literature review", *International Journal Of Heavy Vehicle Systems*, 17 (1): 52–75 (2010).

36. Hendricks, B.F., Martin, O.S., and Wekezer, J.W., "Impact Simulation of the 820C Vehicle with the G2 Guardrail", *Federal Highway Administration Vehicle Crash Analysis*, Report FHWA-RD-96-212, FHWA, Washington DC, (1996).
37. Claude, J-F., Ahmed, E., Cusson, D., and Benmokrane, B., "Early-age cracking of steel and GFRP-reinforced concrete bridge barriers", *CSCE Annual Conference*, 1-12 (2011).
38. Sheikh, N. M., Alberson, D. C., and Chatham, L. S., "State of the practice of cable barrier systems", *Transportation Research Record*, (2060): 84–91 (2008).
39. Bullard, D., "Performance evaluation of two aesthetic bridge rails", *Technical Report*, 4288-S (2003a).
40. Bullard, D., Buth, C.E., William, F., Menges, W.L., and Rebecca, R.H., "Crash testing and evaluation of the modified T77 bridge rail", *Texas Department of Transportation Research and Technology Implementation Office*, P.O. Box 5080 78763-5080: 1-41, (2003b).
41. Se-Jin, J., Myoung-Sung, C., and Young-Jin, K., "Ultimate strength of concrete barrier by the yield line theory", *International Journal of Concrete Structures and Materials* 2(1): 57-62 (2008).
42. Sheikh, N., Bligh, R., and Menges, W., "Crash testing and evaluation of F-shape barriers on slopes", *Texas Transportation Institute*, (2008).
43. Nauman, S., Bligh, R., and Menges, W., "Development and testing of a concrete barrier design for use in front of slope or on MSE wall", *Texas Transportation Institute Proving Ground*, (2009).
44. Borkowski, W., Hryciow, Z., Rybak, P., et al., "Testing the results of a passenger vehicle collision with a rigid barrier", *J KONES Powetrain Transp*, 17: 51–57 (2010).
45. Dancygier, AN., "Scaling of non-proportional non-deforming projectiles impacting reinforced concrete barriers", *International Journal of Impact Engineering*, 24(1): 33-55 (2000).
46. Atahan, A.O., "Finite-element crash test simulation of New York portable concrete barrier with I-shaped connector", *Journal of Structural Engineering-ASCE*, 132(3): 430-40 (2006).
47. Sturt, R., and Fell, C., "The relationship of injury risk to accident severity in impacts with roadside barriers", *International Journal of Crashworthiness*, 14(2): 165-72 (2009).
48. Abu-Odeh, A., Kim, K., Williams, W., and Patton, C., "Crash wall design for Mechanically Stabilized Earth (MSE) retaining wall phase I", *Engineering Analysis and Simulation, Texas Transportation Institute*, (2011).

49. Dhafer, M., Dao, C., Kan, S., and Opiela, K., "Safety performance evaluation of concrete barriers on curved and superelevated roads", *The National Crash Analysis Center*, 1-17 (2011).
50. Zhang, R., Pref, M., and Utilization, W., "Timber Guardrail Combined of Round Log Rails and Concrete Posts", (1999).
51. Leijten, A. J. M., "Impact crash and simulation of timber beams", *Computational Engineering*, 30: 859–868 (2001).
52. Daniel, J.M., and Kirk, A.R., "Precast concrete barrier crash testing", *Oregon Department of Transportation Research Group*, (2001).
53. El-Salakawy, E., Benmokrane, B., Radhouane, M., Frédéric, B., and Breauwier, E., "Concrete bridge barriers reinforced with glass fiber-reinforced polymer composite bars", *ACI Structural Journal*, 100 (6):815-24 (2003).
54. El-Salakawy, E., Masmoudi, R., Benmokrane, B., Frédéric, B., and Gérard, D., "Pendulum impacts into concrete bridge barriers reinforced with glass fibre reinforced polymer composite bars", *Canadian Journal of Civil Engineering*, 31(4): 539-52 (2004).
55. Erginbaş, C., "Evaluation of Roadside Barrier Performance: A Case Study in Istanbul", (2008).
56. Noda, R., Kayo, C., Yamanouchi, M., and Shibata, N., "Life cycle greenhouse gas emission of wooden guardrails: a study in Nagano Prefecture", *Journal Of Wood Science*, 62 (2): 181–193 (2016).
57. Bielenberg, R. W., Reid, J. D., Faller, R. K., Rosenbaugh, S. K., and Lechtenberg, K. A., "Performance of the Midwest guardrail system with rectangular wood posts", *Transportation Research Record*, 2437 (2214): 27–40 (2014).
58. Report, F., "Condition assessment treated-timber guardrail posts", (2010).
59. Birinci, E., Yorur, H., Yumrutas, H. I., and Duyar, A., "Evaluation of Renewable Hybrid Barriers in Term of Carbon Emission with Concrete and Steel Barriers", *Forestist*, 71(1) (2020). <https://doi.org/10.5152/forestist.2020.20025>.
60. Birinci, E., "Renewable Hybrid Barrier Design and Determination of Crash Performance", *Karabuk University, PhD. Thesis*, (2021).
61. Yumrutas, H. I., and Yorur, H., "Eighth Int. Conf. Appl. Sci. Manag. Technol" ICASMT 2017, UAE, 59: 30–33 Dubai, (2017).
62. AASHTO (American Association of State Highway Transportation Officials), "A Policy on Geometric Design".

63. Zhiwei, Z., Chenghu, W., and Meng, L., "The Development of New Steel Backing Wood Landscape Guardrail", 983: 312–318 (2014).
64. Fang, H., Wang, Q., and Weggel, D. C., "Advances in Engineering Software Crash analysis and evaluation of cable median barriers on sloped medians using an efficient finite element model", *Advances in engineering software*, 82: 1–13 (2015).
65. Alberson, D. C., Bligh, R. P., Buth, C. E., and Bullard, D. L., "Cable and Wire Rope Barrier Review", (03): 95–104 (1851).
66. Villwock, N. M., Blond, N., Tarko, A. P., and Asce, A. M., "Cable Barriers and Traffic Safety on Rural Interstates", (April): 248–259 (2011).
67. Davids, W. G., Botting, J. K., and Peterson, M., "Development and structural testing of a composite-reinforced timber highway guardrail", *Construction and Building Materials*, 20 (9): 733–743 (2006).
68. Yeginobali, A., Atahan, A.O., and Gozen, A., "Concrete barriers (guardrails) ", Ankara, (2011).
69. Peng, L., Guo, D., and Liu, H., "Research on Application Performance of Surface Anti-corrosion Technology of Corrugated Steel Beam Guardrails", 787: 10–13 (2013).
70. Ren, Z. and Vesenjak, M., "Computational and experimental crash analysis of the road safety barrier", *Engineering Failure Analysis*, 12 (6 SPEC. ISS.): 963–973 (2005).
71. Jama, H. H., Grzebieta, R. H., Friswell, R., and McIntosh, A. S., "Characteristics of fatal motorcycle crashes into roadside safety barriers in Australia and New Zealand", *Accident Analysis And Prevention*, 43 (3): 652–660 (2011).
72. Faller, R. K., Kretschmann, D. E., Reid, J. D., Hascall, J. A., and Sicking, D. L., "Midwest Guardrail System with round timber posts", *11th World Conference On Timber Engineering 2010*, WCTE 2010, 3 (2120): 2336–2341 (2010).
73. Rica, C., "A new approach to health", 20 (2): 216–221 (1976).
74. Transportation Research Board, "Standards for Testing, Evaluating, and Locating Roadside Safety Features", (June): (2002).
75. Road, P. and Barrier, S., "Specification for Road Safety Hardware Systems", (January): (2019).
76. Haixia, Y., Zhiwei, Z., and Hongsong, Z., "Technique Research on High Strength Low Alloy Structural Steel Used in Semi-Rigid Guardrail", 983: 141–147 (2014).

77. Findley, D., Cunningham, C., Schroeder, B., Vaughan, C., and Fowler, T., "Structural and safety investigation of statewide performance of weathered steel beam guardrail in North Carolina", *Transportation Research Record*, (2309): 63–72 (2012).
78. Sheikh, N. M., Bligh, R. P., Albin, R. B., and Olson, D., "Application of Precast Concrete Barrier Adjacent to Steep Roadside Slope", 121–129 .
79. Reid, J. D., "Approach slopes for midwest guardrail system", *Journal of Transportation Safety and Security*, 1 (1): 32–45 (2009).
80. Teng, T.-L., "Impact Performance of W-beam Guardrail Supported by Different Shaped Posts", *International Journal of Mechanical Engineering And Applications*, 4 (2): 59 (2016).
81. Safety, R., "Motorcyclists and Road Restraint Systems in Europe Coordinated policy-making for Safer Road Restraint", 1–5 (2011).
82. Alberta Transportation, "Roadside Design Guide", 2018 (2006).
83. URL1 - <https://www.abc4.com/news/local-news/rider-flown-to-hospital-after-motorcycle-hit-guardrail-near-heber/>
84. Anderson, C., Dua, A., and Sapkota, J., "Motorcycle safety barrier trials in South Australia: Case study–Adelaide Hills", *Australasian College Of Road Safety Conference, Sydney*, (1982): 1–16 (2012).
85. Yumrutaş, H. İ., and Yörür, H., "Hybrid Road Barrier Design as Aesthetic Safety Feature and Urban Furniture". *International Journal of System Modeling and Simulation*, 2(2):23-26 (2017).
86. Coon, B. A. and Reid, J. D., "Reconstruction techniques for energy-absorbing guardrail end terminals", *Accident Analysis And Prevention*, 38 (1): 1–13 (2006).
87. By, M., Treash, K., and Amaratunga, K., "A Utomatic R Oad D Etection in", 2 (January): 60–69 (2000).
88. Bligh, R. P., Mak, K. K., and Menges, W.L., "Crash testing and evaluation of existing guardrail systems", (1998).
89. Hong, H. A. O., Andrew, D. J., and Chengqing, W. U., "Numerical Simulations of the Performance of Steel Guardrails Under Vehicle Impact", (2008).
90. Bruski, D., "Determination of the Bending Properties of Wire Rope Used in Cable Barrier Systems", (1997): (2020).
91. Judge, R., and Yang, Z., "Numerical Simulation of Spiral-Strand Cables Subjected To High Velocity Fragment Impact" *In Proceedings of the 8th European LS-DYNA Users Conference*, (May): 23–24 Strasbourg (2011).

92. Vukelic, G., and Vizentin, G., "Damage-induced stresses and remaining service life predictions of wire ropes", *Appl. Sci.*, 107 (7): (2017).
93. Erdönmez, C., and Imrak, C. E., "Modeling and numerical analysis of the wire strand", *J. Nav. Sci. Eng.*, (6): 30–38 (2009).
94. Foti, F., and de Luca di Roseto, A., "Analytical and finite element modelling of the elastic–plastic behaviour of metallic strands under axial–torsional loads", *International Journal of Mechanical Science*, 115–116, 202–214 (2016).
95. Jiang, T., Grzebieta, R. H., and Zhao, X. L., "Predicting impact loads of a car crashing into a concrete roadside safety barrier", (2004).
96. Li, S., Newbolds, S., Zhu, K., and Menne, H., "In-Service Performance Evaluation of a Cable Median Barrier System on Interstate Highways", (April): 163–170 (2013).
97. Esfahani, E., Dhafer, M., and Kenneth, S.O., "Safety performance of concrete median barriers under updated crash-worthiness criteria", *The National Crash Analysis Center*, 1-12 (2008).
98. Zhao, J., Lei, Z., Wang, S., Li, Y., and Lei, M., "Optimization of the level of SS crash barrier Overpass Bridge on highway", *2011 2nd International Conference On Mechanic Automation And Control Engineering*, MACE 2011 - Proceedings, 2346–2349 (2011).
99. Pilia, F., Maltinti, F., and Annunziata, F., "Preliminary Results on a New Safety Road Barrier Made Completely of Wood.", *Environmental Semeiotics*, 5 (2): 11–23 (2012).
100. Davids, W. G., Botting, J. K., and Peterson, M., "Composite-reinforced timber highway guardrail: Development and structural testing", *9th World Conference On Timber Engineering 2006*, WCTE 2006, 1: 703–710 (2006).
101. Leitplanke, E., "The first full timber guardrail for highways Erste Leitplanke aus Vollholz für Straßenklasse Autobahn", *Internationale Holzbrückentage*, 1–10.
102. Weaver, C. A., Asce, S. M., Davids, W. G., Asce, M., Dagher, H. J., and Asce, M., "Testing and Analysis of Partially Composite Fiber-Reinforced Polymer-Glulam-Concrete Bridge Girders", 9 (4): 316–325 (2004).
103. Zhiwei, Z., Chenghu, W., and Meng, L., "The Development of New Steel Backing Wood Landscape Guardrail", *Advanced Material Research*, 983: 312–318 (2014).
104. Zhang, X., Chen, J., Dias, A. C., and Yang, H., "Improving carbon stock estimates for in-use harvested wood products by linking production and consumption

- a global case study", *Environmental Science and Technology*, 54 (5): 2565–2574 (2020).
105. Poran, C. J., and Rodriguez, J. A., "Finite Element Analysis of Impact Behavior of Sand", *Soil and Foundations*, 32(4):68-80 (1992).
106. Ho, T. S., and Masuya, H., "Finite element analysis of the dynamic behavior of sand-filled geocells subjected to impact load by rockfall", *International Journal of Erosion Control Engineering*, 6(1):1-12 (2013).
107. Chian, S. C., Tsn, B.C.V., and Sarma, A., "Reprint of: Projectile penetration in to sand: Relative density of sand and projectile nose shape and mass", *International Journal of Impact Engineering*, 105: 80-88 (2017).
108. Malek, A. S., Meyer, L. W., and Herzig, N., "Mechanical behavior of sand under high pressure and high strain rate", EPJ Web (2012).
109. Sabet, A. R., Behesty, M. H., and Rahimi, H., "Experimental Study of Sharp-Tipped Projectile Perforation of GFRP Plates Containing Sand Filler Under High Velocity Impact and Quasi-Static Loadings", *Polymer Composites*, 1498-1509 (2009).
110. Arun, G., "Yığma Kagir Yapı Davranışı", YDGA2005 - Yığma Yapıların Deprem Güvenliğinin Arttırılması Çalıştayı, ODTÜ, ANKARA (2005).
111. Bhatti, A. Q., "Falling-weight impact response for prototype RC type rockshed with sand cushion", *Materials and Structures* (2014).
112. Goubel, C., Massenzio, M., and Ronel, S., "Wood-Steel Structure for Vehicle Restraint Systems", Wood-Steel Structure for Vehicle Restraint Systems", *8th European LS-DYNA Users Conference*, (May): (2011).
113. Fatih Özalp, Fatih Pilis, Halit Dilşad Yılmaz, Şenol Yaşar, A. O. A., "Anahtar sözcükler: Beton bariyer, CE belgesi, servis ömrü, çarpışma testi", *10. Beton Kongresi*, 447–455 (2019).
114. Muhammad, M. F. and Mohammed, H. J., "Concrete Road Barriers Subjected to Impact Loads: An Overview", *Latin American Journal of Solids and Structures*, 1824–1858 (2015).
115. Dobrovolny, C. S., Shi, S., Kovar, J., and Bligh, R. P., "Development and Evaluation of Concrete Barrier Containment Options for Errant Motorcycle Riders", 2673 (10): 14–24 (2019).
116. Montella, A., "Selection of roadside safety barrier containment level according to European Union Standards", *Transportation Research Record*, (1743): 104–110 (2001).

117. "Roadside Safety Design and Devices: International Workshop", *Roadside Safety Design and Devices: International Workshop*, (2013).
118. Hong, H. A. O., Andrew, D. J., and Chengqing, W. U., "Numerical Simulations of the Performance of Steel Guardrails Under Vehicle Impact", (2008).
119. Gabauer, D.J., Kusano, K.D., Marzougui, D., Opiela, K., Hargrave, M., and Gabler, H. C., "Pendulum testing as a means of assessing the crash performance of longitudinal barrier with minor damage", *International Journal of Impact Engineering*, 37, (11): 1121–1137 (2010).
120. Gierczycka, D., Watson, B., and Cronin, D., "Investigation of occupant arm position and door properties on thorax kinematics in side impact crash scenarios-comparison of ATD and human models", *International Journal of Crashworthiness*, 20 (3): 242–269 (2015).
121. Mitchell, G., Strahota, M. T., Gokani, V., Picon, R., Yang, S., Clinger, R. E., and Williamson, E. B., "Performance of retrofit highway barriers with mechanical anchors", *ACI Structural Journal*, 107 (4): 381–389 (2010).
122. Moreno-Perez, F., Barroso, A., Canas, J., and Paris, F., "Influence of the size and depth of a circumferential notch on the impact behaviour of streetlights. A passive-safety concept", *Engineering Failure Analysis*, 53: 15–23 (2015).
123. Raj, A., Nagarajan, P., and Aikot Pallikara, S., "Application of fiber-reinforced rubcrete for crash barriers", *Journal of Materials in Civil Engineering*, 32 (12): 04020358 (2020).
124. Yamaguchi, G. T., Dainty, D., Lam, T., and Watson, H., "Performance of certified climbing helmets during simulated climbing falls", *Journal of Testing and Evaluation*, 42 (5): 20130122 (2014).
125. Gatchell, C. J. and Michie, J. D., "Pendulum impact tests of wooden and steel highway guardrail posts", (1974).
126. Gentry, T. R., "Pendulum impact tests on steel w-beam guardrails", (1998).
127. Gabauer, D. J., Kusano, K. D., Marzougui, D., Opiela, K., Hargrave, M., and Gabler, H. C., "Pendulum testing as a means of assessing the crash performance of longitudinal barrier with minor damage", *International Journal Of Impact Engineering*, 37 (11): 1121–1137 (2010).
128. Marzougui, D., "Development of a New End Treatment for Steel-Backed Timber Guardrail : Phase I Conceptual Design", (2009).
129. Kurtuluş, E., "Yeni nesil otokorkuluk sistemlerinin çarpışma analizleri ve sezgisel optimizasyon yöntemleri kullanılarak geliştirilmesi", *Bursa Teknik Üniversitesi, Yüksek Lisans Tezi*, BURSA (2015).

130. Borovinsek, M., Vesenjok, M., Ulbin, M. and Ren, Z., "Simulation of Crash Test for High Containment Levels of Road Safety Barriers", *Engineering Failure Analysis*, 14:1711-1718 (2007).

131. Gmrk, R., "Œekil verme iŒleminin arpma performansına etkilerinin sonlu elemanlar yntemi ile incelenmesi", *Karadeniz Teknik niversitesi, Yksek Lisans Tezi*, TRABZON (2006).

132. Bayat, E., "arpıŒma testi ve simlasyon kullanılarak yeni nesil H1 seviye otokorkuluk geliŒtirilmesi", *BaheŒehir niversitesi, Yksek Lisans Tezi*, İSTANBUL (2012).

133. Pilia, F., Maltinti, F., and Annuziata, F., "Preliminary Results on a New Safety Road Barrier Made Completely of Wood", *Enviromental Semeiotics*, 5(2):11-23 (2012).

RESUME

Mohammed Jalil ANWER. He completed his primary and secondary education in Kirkuk city. After completing his high school education in Qazy Mohammed in the same city, he started his undergraduate program at Kirkuk University Civil Engineering Department in 2014. After graduating from the Department of Civil Engineering in 2018, he started to work as laboratory engineer in a company and as an effectuate and supervision engineer in 2018. In 2019, he started his master thesis at Karabuk University Institute of Graduate Programs, Department of Civil engineering.