



**THE EFFECT OF CHARGING ELECTRIC
VEHICLES ON DISTRIBUTION GRID OF THE
RESIDENTIAL AREA**

**2024
MASTER THESIS
ELECTRICAL AND ELECTRONICS
ENGINEERING**

Abdullah GHAYTH

**Thesis Advisor
Assist. Prof. Dr. Mehmet ŞİMŞİR**

**THE EFFECT OF CHARGING ELECTRIC VEHICLES ON
DISTRIBUTION GRID OF THE RESIDENTIAL AREA**

Abdullah GHAYTH

**Thesis Advisor
Assist. Prof. Dr. Mehmet ŞİMŞİR**

**T.C.
Karabuk University
Institute of Graduate Programs
Department of Electrical and Electronics Engineering
Prepared as
Master Thesis**

**KARABUK
June 2024**

I Certify That, The Thesis Submitted by Abdullah GHAYTH Titled" THE EFFECT OF CHARGING ELECTRIC VEHICLES ON DISTRIBUTION GRID OF THE RESIDENTIAL AREA” Is Fully Adequate in Scope and Quality as A Thesis for The Degree Of Master of Science.

Assist. Prof. Dr. Mehmet ŞİMŞİR
Thesis Advisor, Department of Electrical and Electronics Engineering

This thesis is accepted by the examining committee with a unanimous vote in the Department of Electrical and Electronics Engineering as a Master of Science thesis.
June 5, 2024

Examining Committee Members (Institutions) Signature

Chairman : Assist. Prof. Dr. Mehmet ŞİMŞİR (KBÜ)

Member : Assist. Prof. Dr. Selçuk Alparslan AVCI (KBÜ)

Member : Assist. Prof. Dr. Ahmet ÇİFCİ (MAKÜ)

The degree of Master of Electrical and Electronics Engineering by the thesis submitted is approved by the Administrative Board of the Institute of Graduate Programs, Karabük University.

Assoc. Prof. Dr. Zeynep ÖZCAN
Director of the Institute of Graduate Programs



The information included in this thesis was fully gathered and presented in compliance with academic rules and ethical guidelines, I therefore declare. Furthermore, I have assiduously followed the guidelines and standards set forth by these rules, properly citing any sources that are not the author's own."

Abdullah GHAYTH

ABSTRACT

M. Sc. Thesis

THE EFFECT OF CHARGING ELECTRIC VEHICLES ON DISTRIBUTION GRID OF THE RESIDENTIAL AREA

Abdullah GHAYTH

Karabük University

Institute of Graduate Programs

Department of Electrical and Electronics Engineering

Thesis Advisor:

Assist. Prof. Dr. Mehmet ŞİMŞİR

June 2024, 79 pages

This thesis investigates the effect of electric vehicle (EV) charging on the electricity distribution grids of residential areas. With the rapid increase in EV adoption, the additional load from EV charging poses potential challenges to existing residential distribution grids. The primary focus of this research is to understand how EV charging affects grid stability, power quality, and energy losses. To this end, a detailed model of the distribution grid was developed, incorporating the variable loads induced by EV charging over different periods. Through this model, the study explores the relationship between EV adoption rates and charging patterns, particularly analyzing their effects on the voltage profiles within the grid. Furthermore, the research quantifies the extent of power losses resulting from the increased demand created by EV charging. The findings aim to offer insights into the grid management complexities introduced by EVs and suggest practical approaches for enhancing grid reliability and efficiency. The results are intended to aid utilities

and policymakers in making informed decisions to accommodate the growing presence of EVs, ensuring a smoother transition towards sustainable transportation electrification.

Keywords : Electric Vehicles, Residential Distribution Grid, EV Charging Impact, Grid Stability, Power Losses, Voltage Profile.

Science Code : 90513



ÖZET

Yüksek Lisans Tezi

ELEKTRİK ARABALARININ ŞARJ EDİLMESİNİN KONUT ALANLARINDAKİ DAĞITIM ŞEBEKESİ ÜZERİNDEKİ ETKİSİ

Abdullah GHAYTH

Karabük Üniversitesi

Lisansüstü Eğitim Enstitüsü

Elektrik ve Elektronik Mühendisliği Anabilim Dalı

Tez Danışmanı:

Dr. Öğr. Üyesi Mehmet ŞİMŞİR

Haziran 2024, 79 sayfa

Bu tez, elektrikli araçların (EV) şarj olmasının konut alanlarının elektrik dağıtım şebekeleri üzerindeki etkisini araştırmaktadır. Elektrikli araçların hızla artan benimsenmesi ile birlikte, EV şarjından kaynaklanan ek yük, mevcut konut dağıtım şebekeleri için potansiyel zorluklar oluşturmaktadır. Bu araştırmanın temel odak noktası, EV şarjının şebeke istikrarını, güç kalitesini ve enerji kayıplarını nasıl etkilediğini anlamaktır. Bu amaçla, farklı dönemlerde EV şarjı tarafından indüklenen değişken yükleri içerecek şekilde detaylı bir dağıtım şebekesi modeli geliştirilmiştir. Bu model aracılığıyla, çalışma EV benimsenme oranları ile şarj modelleri arasındaki ilişkiyi araştırmakta, özellikle şebeke içindeki voltaj profilleri üzerindeki etkilerini analiz etmektedir. Ayrıca, araştırma EV şarjından kaynaklanan artan talep sonucu ortaya çıkan güç kayıplarının boyutlarını nicel olarak belirlemektedir. Bulgular, EV'lerin getirdiği şebeke yönetimi karmaşıklıklarına dair içgörüler sunmayı ve şebeke güvenilirliği ile verimliliğini artırmak için pratik yaklaşımlar önermeyi

amaçlamaktadır. Sonuçlar, elektrikli araçların artan varlığını karşılamak için bilinçli kararlar alınmasına yardımcı olmak üzere kamu hizmetleri ve politika yapıcılarına yöneliktir, sürdürülebilir taşımacılığa elektrifikasyonuna doğru daha sorunsuz bir geçiş sağlamayı hedeflemektedir.

Anahtar Kelimeler : Elektrikli Araçlar, Dağıtım Şebekesi, EV Şarj Etkisi, Şebeke Kararlılığı, Güç Kayıpları, Gerilim Profili.

Bilim Kodu : 90513



ACKNOWLEDGMENT

I am incredibly appreciative to Allah for granting me the opportunity to pursue my goal of earning a master's degree at one of the most prestigious colleges in Turkey. Over the past two years, this journey has been an incredible experience filled with priceless memories and enduring feelings.

I extend my deepest gratitude to my advisor, Dr. Mehmet ŞİMŞİR, whose exceptional support and significant contributions were instrumental in the completion of this thesis.

To my dear Mother and Father, who have been my unwavering pillars of support, I express my heartfelt thanks. Thank you for believing in me and encouraging me to persevere through all the challenges I faced.

I dedicate this achievement to my parents, my homeland, my advisor, and my friends, whose unwavering presence provided the courage and support necessary to see this endeavor through to fruition. Thanks a lot.

CONTENTS

	<u>Page</u>
APPROVAL.....	ii
ABSTRACT.....	iv
ÖZET.....	vi
ACKNOWLEDGMENT.....	viii
CONTENTS.....	ix
LIST OF FIGURES	xii
LIST OF TABLES	xiii
INDEX OF ABBREVIATIONS	xiv
PART 1	1
INTRODUCTION	1
1.1. MOTIVATION	3
1.2. PROBLEM STATEMENT	4
1.3. RESEARCH OBJECTIVE.....	5
1.4. CONTRIBUTION	5
1.5. THESIS SCOPE.....	6
1.6. STRUCTURE OF THESIS	7
PART 2	8
LITERATURE REVIEW.....	8
2.1. ELECTRIC VEHICLES	8
2.2. ADVANTAGE OF ELECTRIC VEHICLES	9
2.3. EFFECT OF GRID-CONNECTED EV SYSTEMS.....	10
2.3.1. Voltage Drops	10
2.3.2. Voltage Unbalance	11
2.3.3. Harmonics	11
2.3.4. Power Loss	12
2.3.5. Equipment Overloading	12
2.4. CONTRIBUTION OF PREVIOUS STUDIES.....	13

	<u>Page</u>
2.5. CHAPTER SUMMARY	18
PART 3	20
THEORETICAL ANALYSIS OF GRID-CONNECTED EV.....	20
3.1. VEHICLE TECHNOLOGIES	20
3.1.1. Battery Electric Vehicles	24
3.1.2. Fuel Cell Electric Vehicle.....	26
3.1.3 Internal Combustion Engine	27
3.1.4. Hybrid and Plug-In Hybrid Vehicles.....	27
3.2. EV INTEGRATION INTO THE LOW VOLTAGE DISTRIBUTION	29
3.3. CHARGING INFRASTRUCTURE.....	31
3.3.1. Slow Charging	32
3.3.2. Fast Charging.....	32
3.4. CHARGING STATIONS.....	33
3.4.1. Electric Vehicle Supply Equipment	35
3.4.2. EV Charging Modes and Charging Stations Level.....	35
3.4.3. Conductive Chargers	37
3.4.4. Inductive Charger	37
3.4.5. Battery Swapping.....	37
3.4.6. Wireless Charging	38
3.5. CHAPTER SUMMARY	38
PART 4	39
METHODOLOGY	39
4.1. INTRODUCTION.....	39
4.2. RESEARCH FLOWCHART	39
4.3. RESEARCH PROGRESS	44
4.4. COLLECTION OF DATA.....	44
4.5. THE INVESTIGATION OF DISTRIBUTION GRID	44
4.5.1. Phase Allocation	45
4.5.2. Distribution Grid Parameters.....	45
4.5.3. Power Factor of Loads.....	45
4.6. DISTRIBUTION GRID IMPLEMENTATION	45

	<u>Page</u>
4.7. NEPLAN PROGRAM	46
PART 5	48
RESULT AND DISCUSSION	48
5.1. THE PARAMETER OF THE PROPOSED SYSTEM MODELING OF GRID-CONNECTED EV	48
5.2. MODELING OF GRID-CONNECTED EV	49
5.3. RESULT FROM MODELING OF GRID-CONNECTED EV	51
5.3.1. VOLTAGE PROFILE ON DIFFERENT BUSES WITHOUT EV	51
5.3.2. The Results of Real Power (MW) Generation.....	55
5.3.3. The Results of Loading Profile of Distribution's Network and Transformer	56
PART 6	59
CONCLUSION AND FUTURE WORK	59
6.1. CONCLUSION	59
6.2. FUTURE WORK	60
REFERENCES.....	63
RESUME	80

LIST OF FIGURES

	<u>Page</u>
Figure 3.1. The classification of EVs.....	22
Figure 3.2. The diagram of battery electric vehicles.....	26
Figure 3.3. The diagram of fuel cell electric vehicles.....	27
Figure 3.4. The diagram of full hybrid EV classification. (a) Series hybrid EV, (b) Parallel hybrid EV, (c) Parallel–series hybrid EV.....	28
Figure 3.5. Impacts of EV distribution grid-interfaced.....	30
Figure 3.6. Three primary types of EV charging technologies.....	34
Figure 3.7. EV supplies equipment.....	36
Figure 4.1. The flowchart of the impact of EVs in the distribution Network’s voltage profile and Energy losses.....	40
Figure 5.1. The diagram of proposed modeling using the Neplan software program.....	50
Figure 5.2. The result of voltage on different buses without EV.....	52
Figure 5.3. The results of voltage range (%) on different buses without EV.....	53
Figure 5.3. The results of voltage range (%) on different buses without EV.....	53
Figure 5.4. The results of voltage range (%) of distribution’s network transformer with EV.....	53
Figure 5.5. The results of bus voltages (P.U) of distribution’s network with EV...	54
Figure 5.6. The results of charging voltages (MW) of distribution’s network with EV.....	54
Figure 5.7. The results of obtaining (Real Power (MW)) based on generation.	55
Figure 5.8. The results of Real Power loss (MW) with EV.....	56
Figure 5.9. The results of the Real power loss (MW) of the distribution network transformer with EV.....	56
Figure 5.10. The results of loading profile of distribution’s network without EV. ..	57
Figure 5.11. The results of the load profile of the entire distribution network transformer with EV.....	58
Figure 5.12. The results of loading of distribution’s network transformer without EV.....	59
Figure 5.13. The results of loading of distribution’s network transformer with EV. 59	59

LIST OF TABLES

	<u>Page</u>
Table 2.1. The latest research on the impact of EVs integrated with the distribution grid.	13
Table 3.1. Advantages and limitations of electric and ICE vehicles	23
Table 3.2. Negative impacts of EV PG-interfaced.....	31
Table 3.3. Positive impacts of EV DG-interfaced.....	31
Table 3.4. Different countries, symbols, connectors, charging modes, and standards of EVs	36
Table 5.1. The parameter of the proposed system	48

INDEX OF ABBREVIATIONS

ICE	: Internal combustion engine
EV	: Electric vehicles
GHG	: Greenhouse gas
CO ₂	: Carbon dioxide
NO ₂	: Nitrogen dioxide
VUF	: Voltage Unbalance Factor
TDD	: Total Demand Distortion
THD	: Total Harmonic Distortion
RMS	: The root mean square
DG	: Distribution grid
HEDQN	: Hierarchical enhanced deep Q network
FBI	: Forensic-based investigation
AOA	: The Archimedes optimization algorithm
DbRDN	: Dove-based Recursive Deep Network
PDN	: Power distribution network
TN	: Transportation network
EVCSs	: Electric vehicle charging stations
FRTC	: Fault Ride-Through Capability
PSO	: Particle swarm optimization
BEVs	: Battery electric vehicles
SC	: Supercapacitors
SOC	: State of Charge
HEV	: A hybrid electric vehicle
WPT	: Wireless Power Transfer
EVSE	: Electric Vehicle Supply Equipment
WPT	: Wireless power transfer

PART 1

INTRODUCTION

Recently, the global energy landscape is predominantly reliant on fossil fuels for both electricity generation and transportation needs [1]. However, a confluence of emerging energy and environmental concerns, coupled with geopolitical instabilities, economic challenges, energy security apprehensions, and the impending depletion of fossil fuel reservoirs, has served as a clarion call for industries within these sectors to explore alternative energy solutions [2]. Consequently, there has been a discernible paradigm shift within the transportation domain towards the rapid electrification of vehicles as a viable substitute for traditional internal combustion engine (ICE) counterparts. This transition towards electric vehicles (EVs) has been primarily precipitated by the implementation of pragmatic policies aimed at curbing environmental degradation, particularly in terms of greenhouse gas (GHG) emissions, and fostering the long-term sustainability of the transportation sector [3,4].

Furthermore, the integration of EVs into the transportation ecosystem holds promise for significant fiscal savings earmarked for environmental preservation endeavors, alongside a consequential reduction in the reliance on finite oil resources [5]. The manifold advantages inherent in EV adoption have catalyzed a global acceleration in its uptake, buoyed by supportive governmental policies such as tax incentives, the provision of EV-friendly infrastructure including parking and transit facilities, as well as toll exemptions [6,7]. Moreover, with certain nations either enacting or contemplating stringent regulations pertaining to vehicular emissions, automotive manufacturers have been compelled to recalibrate their strategies, with concerted efforts directed towards minimizing the emissions output of ICE vehicles while concurrently investing in the research and development of cutting-edge EV technologies. This adaptive response underscores the industry's commitment to

aligning with evolving environmental benchmarks and reinforces the pivotal role that EVs are poised to play in shaping the future of sustainable transportation [8].

The burgeoning electric vehicle (EV) market has undergone a trajectory of exponential expansion, evidenced by its attainment of sales figures surpassing the 10 million marks in the annum of 2022. This ascendant trend is further underscored by the revelation that 14% of all recent automotive acquisitions in 2022 constituted electric vehicles, marking a discernible uptick from the approximate figures of 9% and less than 5% observed in the preceding years of 2021 and 2020, respectively. Within the landscape of global EV commerce, three salient markets have emerged as stalwarts. Foremost among these is the Chinese market, which, once more, has asserted its preeminence by commanding approximately 60% of the aggregate global electric vehicle sales. Notably, China now harbors in excess of half of the total global EV fleet, thus surpassing its projected milestone for new energy vehicle sales earmarked for the year 2025 [9,10].

Meanwhile, in Europe, the secondary but nonetheless pivotal market for electric vehicles, a conspicuous surge of over 15% in electric car transactions transpired in 2022. Consequently, this translated to an epoch-making milestone wherein more than one out of every five automotive acquisitions in Europe materialized in the form of electric vehicles. Similarly, in the United States, which constitutes the tertiary but nonetheless substantial market for electric vehicles, the year 2022 bore witness to a striking upswing of 55% in electric car sales, thereby culminating in an 8% share of total automotive sales being attributed to EV [11,12]. Anticipated to persist robustly into the forthcoming year, EV sales are poised for continued momentum throughout the duration of 2023. Evidencing this enduring trend, the inaugural quarter of the year witnessed the sale of over 2.3 million electric cars, marking a formidable surge of approximately 25% in comparison to figures recorded during the corresponding temporal span of the antecedent year. Projections indicate an envisaged culmination of sales figures at a staggering 14 million by the denouement of 2023, thereby delineating a striking year-on-year escalation of 35%, with a notable acceleration in new acquisitions anticipated particularly in the latter half of the annum. Concomitantly, it is surmised that electric cars may ascend to account for an

impressive 18% share of the total automotive transactions conducted over the entire calendar year [13].

Furthermore, envisioned to act as catalyzing agents in fortifying the trajectory of EV sales, national policies and incentivization mechanisms are poised to play pivotal roles. Furthermore, the resurgence of oil prices to levels of exceptional elevation akin to those observed in the antecedent year could conceivably serve as an additional impetus, thereby further galvanizing the resolve of prospective purchasers towards embracing electric alternatives [14,15].

The gap in the thesis lies in the need for addressing of the specific impact of electric vehicle (EV) charging on the distribution grid within residential areas, particularly with regard to voltage profile and power losses. While there is existing research on the broader implications of EV adoption on the electrical grid, there is a lack of detailed analysis focusing specifically on residential distribution grids and their vulnerability to fluctuations in voltage levels and increased power losses due to EV charging activities. Furthermore, there is a dearth of studies that systematically examine the interplay between EV charging patterns and their effects on grid stability and efficiency within residential settings. Addressing this gap is crucial for developing effective strategies for grid management, infrastructure planning, and policy formulation tailored to the unique challenges and opportunities posed by the integration of EVs into residential electricity distribution systems.

1.1. MOTIVATION

The motivation thesis of the effect of charging electric vehicles on distribution grid of the residential area in terms of voltage profile and power losses is to investigate the impact of electric vehicle (EV) charging on the distribution grid within a residential area, specifically focusing on two key aspects: voltage profile and power losses. The study aims to analyze how the increasing adoption of EVs and their charging patterns influence the voltage levels across the distribution grid and the overall power losses incurred. By examining these factors, the thesis seeks to contribute to a better understanding of the challenges and opportunities associated

with integrating EVs into residential electricity distribution systems, ultimately informing decision-making processes regarding grid management, infrastructure planning, and policy development in the context of sustainable transportation electrification.

1.2. PROBLEM STATEMENT

The widespread adoption of electric vehicles (EVs) poses significant challenges to residential electricity distribution systems, particularly regarding voltage profile and power losses within the distribution grid. While the integration of EVs into residential areas offers numerous benefits in terms of sustainability and reduced greenhouse gas emissions, it also presents complexities related to grid stability and efficiency. The existing infrastructure may not be adequately equipped to handle the increased demand for electricity caused by EV charging activities, leading to voltage fluctuations and elevated power losses.

This research aims to address the gap in understanding the precise impact of EV charging on residential distribution grids, with a specific focus on voltage profile and power losses. By investigating the relationship between EV adoption rates, charging patterns, and their effects on voltage levels and power losses across the distribution grid, this study seeks to identify potential challenges and opportunities associated with integrating EVs into residential electricity distribution systems.

The findings of this research are expected to contribute to a better understanding of the complexities involved in managing EV charging within residential areas and to inform decision-making processes regarding grid management, infrastructure planning, and policy development. Ultimately, the goal is to facilitate the transition towards sustainable transportation electrification while ensuring the reliability and efficiency of residential electricity distribution systems.

1.3. RESEARCH OBJECTIVE

The primary objective of this thesis is to investigate the impact of electric vehicle (EV) charging on residential electricity distribution grid. To achieve this objective, the following specific research objectives are outlined:

- Design a model for the distribution grid that incorporates the anticipated load from EV charging activities, taking into account the period of time during EV charging.
- Analyze the relationship between EV adoption rates and charging patterns within residential areas with a specific focus on voltage profile within the distribution grid.
- Evaluate the magnitude of power losses incurred in the distribution grid as a result of increased demand from EV charging.

By addressing these research objectives, the study aims to contribute to a better understanding of the complexities involved in managing EV charging within residential areas and to provide practical recommendations for ensuring the reliability and efficiency of residential electricity distribution systems amidst the transition towards sustainable transportation electrification.

1.4. CONTRIBUTION

The thesis contributes by designing a model for the distribution grid that incorporates the anticipated load from EV charging activities, considering the temporal aspect of EV charging. To begin with, this model provides a systematic framework for assessing the impact of EV charging on distribution grid operation. By analyzing the relationship between EV adoption rates and charging patterns within residential areas, with a specific focus on voltage profile within the distribution grid, the study sheds light on the dynamic interactions between EV penetration and grid performance. Moreover, this analysis helps in understanding the nuances of EV charging behavior and its implications for grid stability. Then, the thesis evaluates the magnitude of power losses incurred in the distribution grid due to increased demand

from EV charging. This assessment provides valuable insights into the efficiency of the distribution grid under varying scenarios of EV adoption and charging patterns.

1.5. THESIS SCOPE

The scope of this thesis encompasses three main aspects, each contributing to a comprehensive understanding of the impact of electric vehicle (EV) charging on residential electricity distribution grids. The thesis focuses on designing a model for the distribution grid that integrates the anticipated load from EV charging activities, while considering the temporal aspect of EV charging. This model serves as a systematic framework for assessing the impact of EV charging on distribution grid operation. The thesis study delves into analyzing the relationship between EV adoption rates and charging patterns within residential areas, with a specific emphasis on the voltage profile within the distribution grid. Through this analysis, the thesis aims to elucidate the dynamic interactions between EV penetration and grid performance, providing insights into the nuances of EV charging behavior and its implications for grid stability.

Lastly, the thesis evaluates the magnitude of power losses incurred in the distribution grid due to increased demand from EV charging. This assessment offers valuable insights into the efficiency of the distribution grid under varying scenarios of EV adoption and charging patterns, further enriching the understanding of the grid's operational dynamics in the context of EV integration. Overall, the thesis scope encompasses a comprehensive investigation into the impact of EV charging on residential electricity distribution grids, ranging from the design of a distribution grid model to the analysis of EV adoption rates, charging patterns, and power losses. Through these endeavors, the study aims to provide valuable insights that contribute to the development of strategies for ensuring the reliability and efficiency of distribution grids amidst the transition towards sustainable transportation electrification.

1.6. STRUCTURE OF THESIS

The first part of this thesis provides an introductory discourse comprising several key components: the motivational impetus, the articulation of the problem statement, delineation of research objectives, elucidation of contributions, and delimitation of the thesis scope. Moreover, Part 2 elaborates on the topic of electric vehicles, encompassing a detailed exploration of the advantages associated with electric vehicles, the implications of grid-connected EV systems, the contributions derived from preceding scholarly work, and a summary of the chapter.

Part 3 of the thesis presents a theoretical analysis of grid-connected electric vehicles (EVs), meticulously examining several pivotal elements. This analysis encompasses an exploration of vehicle technologies, detailing the integration of EVs into low voltage distribution systems and the broader charging infrastructure. Specific focus is placed on the dynamics of slow and fast charging techniques, as well as a comprehensive review of various types of charging stations. Part 4 begins with a diagrammatic representation of research methodology, detailing the structured processes involved. As the advancements in investigative pursuits are documented, the systematic aggregation of empirical evidence is meticulously performed to gather necessary data. This is followed by an examination of the electrical distribution network, which includes the allocation of phases within the network and analysis of characteristic variables of the distribution grid.

Part 5 of the thesis study, researcher explore the parameters, repeated modeling, and results of grid-connected electric vehicles (EV). This includes a detailed analysis of the system's integration and performance. Additionally, the research assesses the voltage profiles at different buses without EV presence, offering a baseline for understanding the impact of EVs on voltage stability. In the part 6 of the thesis study, conclusion and future work encapsulates the synthetization of findings and delineates prospective avenues for subsequent thesis investigation. This segment concisely articulates the key outcomes derived from the integration and modeling of grid-connected electric vehicles (EV), underscoring their consequential impact on the stability and operational efficacy of the electrical distribution network.

PART 2

LITERATURE REVIEW

The literature review section of the research on the effect of charging electric vehicles on the distribution grid of the residential area aims to provide a comprehensive overview of existing studies, research papers, and relevant literature on the topic. It involves critically analyzing and synthesizing the existing knowledge, gaps, and research methodologies employed by previous researchers.

2.1. ELECTRIC VEHICLES

The internal combustion engine (ICE), a mainstay in conventional transportation systems, operates primarily on fossil fuels, which substantially contributes to environmental degradation through emissions of greenhouse gases and other pollutants [16,17]. In contrast, electric vehicles (EVs) represent a transformative approach designed to address these environmental challenges. EVs leverage advancements in battery technology and electric drive systems to offer a cleaner alternative to ICE vehicles, thereby reducing the reliance on fossil fuels and diminishing the ecological footprint of automotive transport. The environmental advantages of EVs, such as zero tailpipe emissions and reduced lifecycle carbon output, are among the primary drivers behind their increasing adoption. This shift is further facilitated by improvements in EV infrastructure, including more widespread and efficient charging solutions, which enhance the practicality of EVs for everyday use. The growing market penetration of EVs is evidenced by escalated sales figures across various regions and vehicle segments [18].

2.2. ADVANTAGE OF ELECTRIC VEHICLES

The advantages of electric vehicles (EVs) compared to conventional internal combustion engine (ICE) vehicles are delineated as follows [19-21]:

- **Zero Emission Impact:** EVs contribute significantly to environmental conservation by not emitting carbon dioxide (CO₂) or nitrogen dioxide (NO₂) during operation. Furthermore, the manufacturing processes associated with EVs are increasingly aligned with eco-friendly practices.
- **Reduced Operational and Maintenance Costs:** The expenses related to the maintenance of EVs and the electricity required for their operation are considerably lower than the maintenance and fuel costs associated with ICE vehicles.
- **Enhanced Comfort and Operational Efficiency:** EVs surpass ICE vehicles in terms of operational efficiency, characterized by minimal vibration and reduced engine noise. This results in a more comfortable travel experience.
- **Simplicity and High Reliability:** The drivetrains of EVs are inherently simpler and more compact, lacking numerous conventional components such as cooling circuits, gear shifts, and clutches. This architectural simplicity reduces maintenance costs and increases vehicle reliability due to fewer mechanical components and reduced wear and tear, leading to lower likelihoods of breakdowns.
- **Increased Accessibility:** The zero-emission feature of EVs allows them access to environmentally sensitive or regulated zones that restrict the entry of ICE vehicles due to their pollutant emissions.

To summarize, Electric vehicles (EVs) offer numerous benefits over traditional internal combustion engine (ICE) vehicles, enhancing their environmental, economic, and operational superiority. EVs are eco-friendly, producing zero emissions of harmful gases like CO₂ and NO₂, and their manufacturing processes are increasingly aligned with green practices. They also present reduced operational and maintenance costs, as the expenses for electricity and upkeep are lower compared to ICE vehicles. In terms of comfort and efficiency, EVs operate with

minimal vibration and noise, making travel more comfortable. Their simpler and more compact drivetrains, which lack many conventional components such as cooling circuits and gearshifts, not only reduce maintenance costs but also enhance reliability and decrease the likelihood of breakdowns. Additionally, the zero-emission characteristic of EVs allows them to access environmentally sensitive areas that are off-limits to ICE vehicles. These advantages highlight the rationale behind the growing adoption of EVs in contemporary transportation systems.

2.3. EFFECT OF GRID-CONNECTED EV SYSTEMS

The integration of electric vehicles (EVs) into the power grid has precipitated substantial modifications in the architecture, strategic planning, and functional operations of the network. Without meticulous analysis and strategic planning of this integration, extensive penetration of EV charging into the conventional grid infrastructure can disrupt its normal operations, leading to a plethora of technical power quality challenges. These include, but are not limited to, voltage drops, voltage imbalances, harmonic distortions, increased system losses, equipment overloading, and issues pertaining to voltage stability. This subsection concisely examines some of these impacts, highlighting the critical need for advanced planning and adaptation in grid management to accommodate the growing influx of electric vehicles [22-27].

2.3.1. Voltage Drops

Voltage drop represents a significant constraint in the incorporation of extensive electric vehicle (EV) charging within low voltage (LV) distribution networks. The process of charging EVs directly from the grid induces voltage drops and deviations at the connection points, which can exacerbate if the penetration level of EV charging escalates significantly. Such a scenario might result in breaches of the regulatory voltage limits set for safe network operation. Consequently, utility companies across various nations are tasked with the imperative of maintaining customer service voltages within permissible thresholds, despite differing grid

specifications. The voltage drop of the network topology is determined as following equation (2.1) [28].

$$\Delta V_D = V_{ref} - V_{min} \quad (2.1)$$

Where, V_{Ref} is a prespecified voltage magnitude at load bus i which is usually set to 1.0 p.u. V_{min} is the minimum bus voltage of the network topology.

2.3.2. Voltage Unbalance

Voltage unbalance in electrical distribution systems arises when there is a disparity in phase voltages either in amplitude or phase shift, deviating from the standard 120-degree relationship, or both. This phenomenon typically results from asymmetrically distributed single-phase loads and impedances across the network and is quantified using the Voltage Unbalance Factor (VUF) [29,30]. VUF is defined as the percentage ratio of the absolute magnitudes of the positive and negative sequence voltage components. EVs, which often connect to low-voltage feeders predominantly loaded with single-phase demands, introduce significant power quality challenges for distribution network operators. Empirical evidence, as detailed in references, indicates a pronounced voltage unbalance attributed to EV charging within distribution systems. Consequently, to facilitate seamless integration of EVs while managing voltage unbalance, utilities must establish specific grid codes and standards [31-33]. Furthermore, comprehensive impact assessments by researchers are essential to devise effective strategies to mitigate these challenges and enhance grid stability.

2.3.3. Harmonics

Harmonics are non-fundamental frequency components of voltage or current within a power system, commonly quantified as Total Demand Distortion (TDD) and Total Harmonic Distortion (THD). TDD represents the root mean square (RMS) ratio of harmonic content, excluding inter-harmonics, to the maximum demand current, whereas THD is calculated as the RMS ratio of harmonic content to the fundamental

current [34,35]. The process of EV charging predominantly introduces harmonics into the electrical grid through power electronic converters. Research documented in [43, 44] indicates that unscheduled and high-rate EV charging contributes significantly to harmonic injection into the grid. The permissible levels of these harmonics are regulated by established grid codes and standards, which aim to maintain power quality and system stability [36,37].

2.3.4. Power Loss

Power loss in transmission lines is an intrinsic characteristic of electrical distribution systems, fundamentally tied to the square of the current flowing through these lines as indicated in reference [38,39]. This relationship underscores how increases in current lead directly to higher power dissipation. With the rising integration of electric vehicles (EVs) into existing distribution networks, there is a significant increase in power losses, largely attributable to feeder overloads and changes in the electrical characteristics of feeder currents. As EV adoption expands, the additional demand imposed by vehicle charging exacerbates these effects, stressing the infrastructure and necessitating careful management of load distribution to mitigate increased losses [40,41]. This surge in power loss not only challenges the efficiency and capacity of power transmission but also calls for strategic enhancements in grid management and technology to accommodate the evolving demand dynamics introduced by widespread EV usage. The network topology's total real power loss is defined by the following formula (2.2).

$$P_{loss} = \sum_{i=1}^{N_{br}} R_i * \frac{P_i^2 + Q_i^2}{V_i^2} \quad (2.2)$$

Where, N_{br} is the number of branches; R_i is the resistance of the i^{th} branch; P_i and Q_i are the real power and reactive power of the i^{th} branch, respectively; and V_i is the voltage magnitude at bus i .

2.3.5. Equipment Overloading

Regarding equipment overloading, the widespread adoption of electric vehicle (EV) charging places considerable demands on the distribution network. This situation necessitates the transfer of substantial amounts of power from the grid to the load, which can result in the overloading of critical network components, including transformers and cables. As more EVs connect to the grid for charging, particularly during peak times, the cumulative load can exceed the designed capacity of existing infrastructure [42,43]. This overloading can lead to increased wear and tear, reduced efficiency, and potentially shorten the lifespan of vital network elements such as transformers and power cables, posing significant challenges to grid reliability and safety. Therefore, managing this load effectively through grid enhancements and smart charging strategies becomes essential to prevent overloading and ensure the sustainable integration of EVs into power systems [45,46].

2.4. CONTRIBUTION OF PREVIOUS STUDIES

The literature review serves as the foundation for the current research, identifying the research gaps and building upon the existing body of knowledge. This subsection meticulously delves into an extensive examination of existing literature pertaining to the ramifications of electric vehicle charging on residential distribution grids. Table 2.1 serves as a valuable adjunct, providing succinct descriptions of the studies discussed within the text.

Table 2.1. The latest research on the impact of EVs integrated with the distribution grid.

Author	Year	Journal	Contribution	Target
Nutkani et al., [47]	2024	Wiley	The burgeoning adoption of Electric Vehicles (EVs) is anticipated to exert a substantial influence on electrical power distribution grid (DG). Extensive efforts have been undertaken to grasp and quantify this impact on the hosting capacity of distribution networks, both with and without the implementation of network management solutions. Such a review is imperative for comprehending the breadth of existing studies, scrutinizing the datasets utilized for impact analysis, and, most importantly, elucidating the findings derived from these investigations.	EV-DG
Jiang et	2024	Science	This paper initiated by formulating a bilevel	EV-

al., [48]		Direct	stochastic optimization model for EV charging navigation, which takes into account diverse uncertainties. Subsequently, it introduces an EV charging navigation approach predicated on the hierarchical enhanced deep Q network (HEDQN) to address the aforementioned stochastic optimization model in real-time. The proposed HEDQN encompasses two enhanced deep Q networks, each designated for optimizing the charging destination and the charging route path of EVs, respectively.	DG
Singh & Kumar [49]	2024	Wiley	This article introduced an innovative approach for the meticulous modeling of EVs within the framework of reliability and adequacy models for DG. The proposed technique synergistically merges forensic-based investigation (FBI) with the Archimedes optimization algorithm (AOA), aptly dubbed the FBIAOA technique. In this direction, the primary aim of this method is to enhance the profitability of rapid charging stations while simultaneously mitigating the escalating energy demand on the SG, which comprises storage systems and renewable energy generation sources such as wind and photovoltaic (PV) systems.	EV-DG
Polisetty et al., [50]	2023	Science Direct	With the escalating rate of electric vehicle adoption, there is a pressing need for the strategic deployment of charging stations to minimize loss and mitigate voltage imbalances. Several existing strategies investigated in this study for optimal charging station deployment have yielded increased power utilization, power loss, harmonic distortion, and voltage imbalances. Hence, a novel Dove-based Recursive Deep Network (DbRDN) has been devised for implementation.	EV-DG
Lai et al., [51]	2023	IEEE	Electric vehicles (EVs) hold significant promise in combating greenhouse gas emissions within the transportation sector, contributing to their steady adoption in several countries. However, the increasing prevalence of EVs can pose challenges to both the power distribution network (PDN) and the transportation network (TN). Therefore, this paper introduces a dynamic pricing strategy for electric vehicle charging stations (EVCSs), aiming to enhance their profitability while mitigating potential adverse effects on both PDN and TN.	EV-DG
Wang et al., [52]	2023	Wiley	This article meticulously accounts for the diverse characteristics inherent in various vehicle models and incorporates user responsiveness, thereby rendering the model more reflective of real-world dynamics. The	EV-DG

			results underscore that the optimized charging and discharging strategy outlined in this study not only reduces charging costs for vehicle owners but also enhances revenue generation from charging stations and the utilization rate of charging piles.	
Hartvigsson et al., [53]	2022	Science Direct	This article endeavored to scrutinize the ramifications of voltage disturbances on Electric Vehicle (EV) batteries and charging systems while introducing a Fault Ride-Through Capability (FRTC) mechanism aimed at enhancing voltage quality.	EV-DG
Balasar et al., [54]	2022	IEEE	This article endeavored to scrutinize the ramifications of voltage disturbances on Electric Vehicle (EV) batteries and charging systems while introducing a Fault Ride-Through Capability (FRTC) mechanism aimed at enhancing voltage quality.	EV-DG
He et al., [55]	2022	PMC	This paper introduces a comprehensive evaluation framework and methodology for Electric Vehicle (EV) charging networks, considering the interplay between traffic networks and power grids. Initially, an EV travel model is developed using a travel probability matrix to scrutinize the spatial and temporal dynamics of EV movements. Subsequently, the interconnected relationship among users, charging networks, road networks, and power grids is examined	EV-DG

In this context, the study builds upon the knowledge base established by previous researchers in the field of the anticipated surge in electric vehicle (EV) adoption, which is driven by government incentives and declining battery costs, necessitates an examination of the ensuing load on the electricity grid. In [56], the study delves into the effects of integrating a substantial fleet of EVs on the power network, considering the spatial variations in vehicle usage, electricity demand, and network configuration. To model uncontrolled charging demand, a conditional probability-based approach is employed, while convex optimization is utilized for smart charging modeling. Stochasticity is accounted for through Monte Carlo simulations. The findings demonstrate that, within Great Britain's power system, smart charging holds the capability to obviate the need for additional generation infrastructure accompanying 100% EV adoption, simultaneously reducing the percentage of distribution networks necessitating reinforcement from 28% to 9%. The implications and generalizability of these results to other power systems are also discussed.

Previous research [57] has focused on the presence of electric vehicles (EVs) that continues to grow, their potential for scheduling and dispatching offers significant benefits to both the power grid and EV users. By fully harnessing the dispatching potential, the power grid can enhance system operation efficiency, while EV users can experience cost savings and improved satisfaction. In light of this, this study presents a charging scheduling method for EVs that considers real-world scenarios, encompassing optimization targets and control strategies. Initially, a dynamic multi-objective optimization scheme is devised, incorporating more realistic optimization objectives for each time period, enabling objective adjustments based on the prevailing circumstances. Subsequently, orderly charging control is achieved through the adaptation of charging start time strategies or variable charging power strategies, promoting battery longevity and mitigating grid load fluctuations. To address this challenge, an enhanced multi-objective particle swarm optimization (PSO) algorithm is proposed. This improved algorithm employs maximum and minimum fitness functions based on dynamic crowding distance and rate of change, while optimizing the inertia weight coefficient and learning factor to enhance algorithm performance. Finally, the numerical examples are presented to validate the effectiveness of the proposed model.

In [58], the study aims to evaluate the potential implications of electric vehicles (EVs), which are already widely deployed and expected to experience exponential growth, on distribution networks. The research focuses on understanding the necessary adaptations and developments that the distribution grid must undergo to accommodate the escalating energy demand posed by EVs. To comprehend the technical constraints of the existing infrastructure and assess the capability of transformers and power lines to handle the increasing penetration of EVs, urban and rural grid models were analyzed to identify disparities in the impacts on high- and low-density networks. Furthermore, an assessment of the impact of fast charging stations was conducted. Simulations were performed using MATLAB software to create scripts, which were then implemented within the DIgSILENT PowerFactory software. This approach facilitated the evaluation of the examined networks and verification of the effectiveness of the proposed solutions. Through these

simulations, the study examined the network performance under various scenarios and identified the most viable strategies for managing the distribution network parameters. Based on the findings, the study recommends several methods for optimizing the distribution network to cope with the analyzed network parameters. Notably, a solution involving the integration of electric vehicles is proposed as a promising approach to address the emerging challenges. By leveraging the capabilities of EVs, the distribution network can be effectively managed to ensure efficient operation and mitigate potential issues associated with the increased load demand.

Recent study [59] discussed the rapid adoption of electric vehicles (EVs) in California has brought forth numerous challenges related to the integration of these vehicles with the electricity grid. To assess the capacity constraints faced by local feeders, this study utilizes real-world feeder circuit level data obtained from PG&E, a major utility in California. By employing a detailed modeling approach, the adoption of EVs is analyzed at the census block level, taking into account actual vehicle charging data to simulate future load patterns on circuits across Northern California. In the most ambitious scenario, where 6 million electric vehicles are adopted throughout California, the study reveals that approximately 443 circuits (nearly 20% of all circuits) in PG&E's service territory would require upgrades to accommodate the increased demand. Alarmingly, only 88 of these circuits currently have planned upgrades scheduled in the future. The costs associated with upgrading these feeders are of paramount importance for utility planning processes, underscoring the significance of considering the impact of EVs on local distribution networks. The findings of this study emphasize the substantial implications of EV adoption on distribution network infrastructure and the pressing need for adequate planning and investment. The identified capacity constraints and the scarcity of planned upgrades highlight the urgency for utilities to address the challenges posed by EVs to ensure the reliability and stability of local power distribution. The research serves as a valuable contribution to the understanding of the critical role played by electric vehicles in shaping local distribution networks and underscores the importance of proactive measures to mitigate potential grid strain caused by their proliferation.

In this study [60], authors present a comprehensive and data-driven model that realistically captures the charging behaviors of future EV adopters in the US Western Interconnection. Our analysis focuses on the critical factors of charging control and infrastructure development, which shape the charging load, and evaluate their impact on the grid using a detailed economic dispatch model that considers the generation mix projected for 2035. This findings reveal that peak net electricity demand experiences an increase of up to 25% under the forecasted adoption scenario, while a stress test involving full electrification results in a 50% surge. Notably, locally optimized charging controls and high reliance on home charging can strain the grid infrastructure. However, shifting the charging paradigm towards uncontrolled, daytime charging demonstrates significant benefits by reducing storage requirements, excess non-fossil fuel generation, ramping needs, and emissions. Based on these results, authors urge policymakers to consider the impacts at the generation level when formulating utility rates and designing charging infrastructure strategies. Promoting a shift from home charging to daytime charging can help alleviate grid strain and optimize resource utilization, thereby fostering a more efficient and sustainable charging ecosystem for EVs.

2.5. CHAPTER SUMMARY

Comprehensively examines the burgeoning field of electric vehicles (EVs), detailing their advantages, the impacts of grid-connected EV systems, and contributions from previous studies, particularly focusing on the integration of EVs with the distribution network. The chapter begins by defining EVs and their operational mechanisms. It explores the technological advancements that have propelled the development and adoption of EVs, underscoring their potential as a sustainable alternative to internal combustion engine vehicles.

The review elaborates on the numerous benefits associated with EVs. These include environmental advantages, such as reduced greenhouse gas emissions and lower air pollutants, stemming from the absence of tailpipe emissions. Furthermore, the review highlights the improved efficiency and performance characteristics of EVs, which contribute to a better user experience.

This section delves into the effects of integrating EVs into the power grid. It addresses the challenges of voltage instability, and the degradation of power quality due to harmonics and voltage drops. The chapter synthesizes key findings from prior research, focusing on the impact of EV integration on the electrical distribution network. Notably, it includes insights from the latest research, which evaluates strategies to mitigate negative impacts, such as smart charging technologies and grid modernization efforts.



PART 3

THEORETICAL ANALYSIS OF GRID-CONNECTED EV

The rapid growth in electric vehicle (EV) adoption presents new challenges and opportunities for distribution grids worldwide. A theoretical analysis of grid-connected EV systems is essential to understand and optimize the complex interactions between EVs and the power grid [61-62]. This analysis aims to explore the impact of widespread EV integration on grid stability, load management, and energy efficiency. The focus will be on examining the demands EVs place on the grid, including peak load scenarios, the implications of charging behaviors, and the potential for bi-directional charging technologies that allow EVs not just to draw power but also to supply it back to the grid. Furthermore, the integration of renewable energy sources with grid-connected EV systems will be considered, assessing how this synergy can facilitate a more sustainable and resilient energy infrastructure. By leveraging theoretical models and simulations, this introduction sets the stage for a detailed exploration of strategies to enhance grid management and adapt to the evolving landscape of transportation electrification [63-65]. The goal is to provide a foundation for designing policies and technologies that ensure a smooth transition to a future dominated by EV.

3.1. VEHICLE TECHNOLOGIES

In the rapidly evolving landscape of modern transportation, vehicle technologies have emerged as a cornerstone of innovation, driving significant advancements in efficiency, safety, and sustainability [66,67]. As global attention shifts towards reducing environmental impact and enhancing energy efficiency, the development and integration of cutting-edge vehicle technologies have become paramount. This introduction explores the various facets of vehicle technologies, ranging from

traditional internal combustion engines to revolutionary electric and hybrid systems, as well as emerging autonomous and connected vehicle technologies. Each type of technology brings its own set of benefits and challenges, reshaping the way manufacturers design vehicles and consumers choose their cars. The surge in electric vehicles (EVs), powered by advancements in battery technology and driven by global environmental concerns, illustrates a major shift towards more sustainable driving solutions. Meanwhile, hybrid vehicles combine the best of gasoline and electric power to optimize fuel efficiency and minimize emissions. Moreover, the advent of autonomous driving technology and connected vehicle systems promises to transform the driving experience, enhance road safety, and improve traffic management [68-70]. As these technologies continue to evolve, they not only contribute to the automotive industry's growth but also have profound implications for energy policy, urban planning, and the broader socioeconomic landscape. Taking into consideration the presented power and energy requirements, various vehicle technologies can be contemplated. The energy consumption $E_{EV\ Consumption}$ can be estimated using following equation (3.1) [71].

$$E_{EV\ Consumption} = E_{drive} + E_{A/C} + E_{Losses} \quad (3.1)$$

Where, E_{drive} driving represents the energy consumed from driving the vehicle, measured in watt-hours (Wh), while $E_{A/C}$ denotes the energy utilized by the air conditioning system, also in watt-hours (Wh). Additionally, E_{Losses} accounts for other energy dissipations, which are estimated to constitute 5% of the total energy consumption. According to the referenced scholarly articles, this model for predicting energy consumption is deemed to be 95% accurate, underscoring its reliability and efficacy in estimating real-world vehicle energy usage. The model for driving energy consumption E_{drive} can be derived by incorporating four distinct force components as specified in the subsequent equation (3.2) [71].

$$E_{drive} = (F_{roll} + F_{drag} + F_{hill} + F_{acceleration}) * v * t \quad (3.2)$$

The equation can be restated in the following way (3.3):

$$F_{roll} + F_{drag} + F_{hill} + F_{acceleration} = mg\mu_{rr}\cos\varphi + \frac{1}{2}\rho C_d A v^2 + mg\mu_{rr}\sin\varphi + \left(m + \frac{4j_w}{r^2} + \frac{j_m G^2}{r^2}\right) a \quad (3.3)$$

Where, m indicates vehicle mass (kg); g is gravitational force (m/s^2); μ_{rr} is rolling resistance coefficient; φ is the hill angle ($^\circ$); ρ is density of air (kg/m^3); C_d is drag coefficient. A presents frontal area of EV (m^2); v is velocity (m/s); j_w is inertia of wheel (kgm^2). r is type radius (m); j_m is inertia of motor (kgm^2); G shows gear ratio; and a is acceleration (m/s^2).

In term of EV technologies, it can be classified based on the type of motor employed, such as single-motor vehicles comprising internal combustion engine (ICE) vehicles, battery electric vehicles (BEVs), Fuel cell electric vehicles (FCEVs), or hybrid vehicles that utilize both ICE and electric motors [72]. The classification of EVs is depicted in Figure 3.1, while the advantages and limitations of electric and ICE vehicles are detailed in Table 3.1. It was important to highlight that vehicles can be categorized based on the type of fuel employed, such as gasoline tanks for ICE vehicles. Besides that, batteries can be paired with supercapacitors (SC) for BEVs and hydrogen tanks and batteries for FCEVs [73].

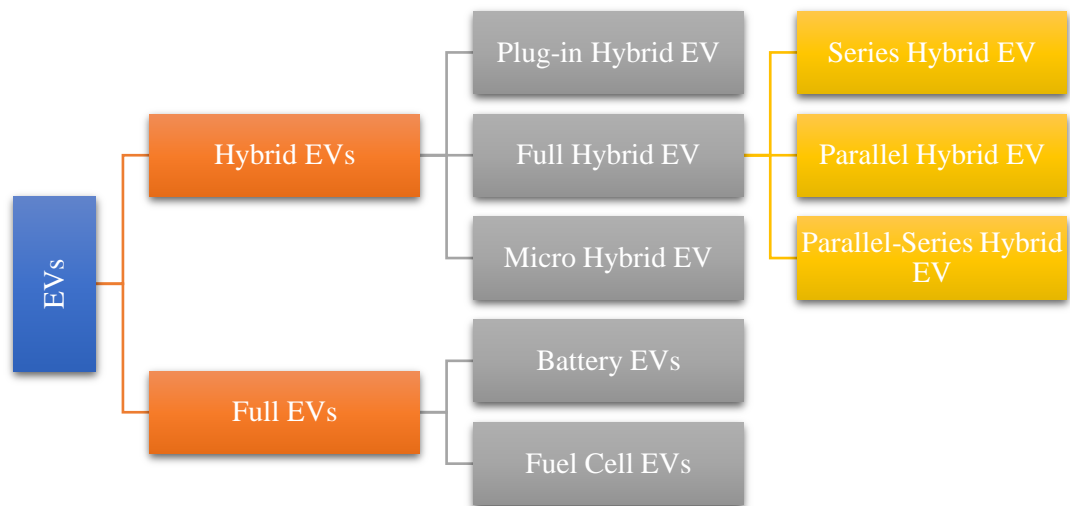

Figure 3.1. The classification of EVs.

In this context, EV offer a range of environmental and operational benefits. They produce zero tailpipe emissions, significantly reducing greenhouse gas emissions and contributing to better air quality. Electric motors are more efficient than internal combustion engines, effectively converting a higher percentage of the electrical energy from the grid to power the wheels [74]. This efficiency translates into reduced operating costs since electricity is generally cheaper than gasoline or diesel, and EVs require less maintenance due to having fewer moving parts.

Table 3.1. Advantages and limitations of electric and ICE vehicles [77-81].

	Advantages	Limitations
EVs	4. High torque can be generated at zero speed, making them efficient for acceleration and starting from a standstill.	5. Limited driving range due to the low energy density of the storage system (less than 200 Wh/kg).
	6. EVs produce no pollutant emissions, making them environmentally friendly and suitable for use in urban areas with stringent air quality regulations.	7. No heat source to warm the vehicle for BEV, which can be a disadvantage in cold climates.
	8. EVs have high efficiency due to the direct conversion of electrical energy to mechanical energy.	9. Lack of hydrogen distribution infrastructure and fast charging stations for FCEV.
ICE	10. The storage system has a high energy density of 12 kWh/kg.	11. Significant greenhouse gas emissions.
	12. There is an infrastructure for energy distribution.	13. Sophisticated and complex mechanical system.
	14. The refueling time is very low, taking less than 5 minutes to fill 60 liters and providing several MW of power.	15. Low overall efficiency.

Furthermore, EVs deliver high torque immediately from a standstill, providing quicker acceleration and a smoother driving experience. They also operate much more quietly than ICE vehicles, contributing to reduced noise pollution. However, EV also have some drawbacks. Range anxiety remains a significant concern due to the generally lower driving range of EVs compared to ICE vehicles. Although charging infrastructure is improving, the availability of charging stations is still limited in many areas, posing challenges for long-distance travel [75,76]. The issues related to battery life, environmental impact of battery production and disposal, and the high initial purchase cost also hinder the widespread adoption of EVs.

ICE vehicles are known for their extended range and quick refueling capabilities, making them ideal for long-distance and unplanned travel. The refueling infrastructure is well-established globally, with gasoline stations readily accessible. Additionally, ICE vehicles typically have lower initial purchase prices compared to electric vehicles, making them more economically accessible to a broader audience. There is also a greater variety of ICE vehicles available, which caters to a wide range of tastes and needs.

On the downside, ICE vehicles are less environmentally friendly. They emit significant levels of carbon dioxide and other pollutants, contributing to climate change and public health issues. The cost of gasoline and diesel can also be quite high and unpredictable, which may lead to increased operational costs over time. Regular maintenance such as oil changes, fuel filter replacements, and emission checks add to the ownership cost and can be time-consuming. Moreover, internal combustion engines are less efficient at converting fuel energy into motion, with a substantial amount of energy lost as heat.

However, electric vehicles also have some drawbacks. Range anxiety remains a significant concern due to the generally lower driving range of EVs compared to ICE vehicles. Although charging infrastructure is improving, the availability of charging stations is still limited in many areas, posing challenges for long-distance travel. The issues related to battery life, environmental impact of battery production and disposal, and the high initial purchase cost also hinder the widespread adoption of EVs.

3.1.1. Battery Electric Vehicle

The battery energy storage system (BESS) is responsible for providing the necessary power for traction and propulsion in battery electric vehicles (BEVs). The range of the EV is primarily determined by the battery capacity and driver behavior. Communication can be simplified at three distinct stages in today's vehicles and charging systems: vehicle, charger, and network. Vehicle interaction is in charge of monitoring the flow of data in the vehicle, which involves the state of charge. Charger communication manages the data flow throughout the EVSE [82-84]. This

requisite energy can be quantified using Equation (3.4). Furthermore, the energy extracted from the electrical network is determined by Equation (3.5). It is postulated that the efficiency of the charger operates at a nominal value of 90%. In this direction, the quantity of energy required to charge a BEVs is contingent upon the State of Charge (SOC) and the battery's capacity as illustrated in Equation (3.6).

$$E_c \left(1 - \frac{SOC}{100} \right) \times C \quad (3.4)$$

$$E_g = \frac{E_c}{\eta} \quad (3.5)$$

$$SOC_{Estimation} = \left(\frac{E_{EV \text{ consumption}}}{EV \text{ battery capacity}} \right) * 100\% + SOC_{contingency} \quad (3.6)$$

In the specified equations, E_c denotes the energy requisite for charging the battery, where C represents the capacity of the battery expressed in kilowatt-hours (kWh). Furthermore, E_g signifies the electrical energy supplied from the network, and η encapsulates the efficiency of the charger. The term " $SOC_{contingency}$ " refers to an additional State of Charge (SOC) that is allocated to accommodate scenarios characterized by uncertainty. The determination of this parameter is predicated upon the user's driving experience as well as the specific characteristics of the vehicle.

The flow of data employed by third-party suppliers is monitored by network communication. EVSE has to satisfy specific power quality demands but has a power output that can vary for different charging scales [85-87]. The power conversion system commonly used in BEVs is depicted in Figure 3.2.

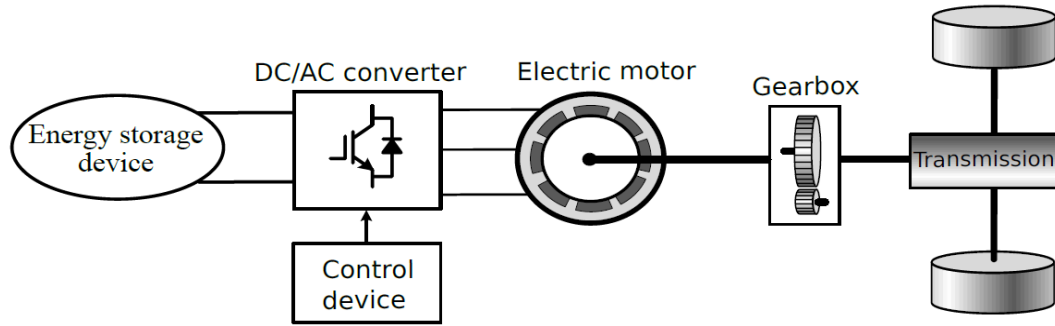

Figure 3.2. The diagram of battery electric vehicles [87].

BEVs are capable of operating in two distinct modes, namely battery mode and regenerative braking mode. In battery mode, a boost DC/DC converter is utilized to transfer power to the motor that propels the wheels via a DC/AC converter. In contrast, during regenerative braking mode, the kinetic energy of the EV is converted into electrical energy and stored in the battery [88-91].

3.1.2. Fuel Cell Electric Vehicle

A fuel cell electric vehicle (FCEV) is an electric vehicle that employs a fuel cell in combination with a small battery or supercapacitor to power its on-board electric motor as demonstrated in Figure 3.3. The fuel cell is the central component of the FCEV, producing electricity through the combination of oxygen in the atmosphere and hydrogen that has been compressed and stored within tanks using focused technological advances at either 350 or 700 bar (10,000 PSI).

FCEVs have earned a reputation as zero-emission vehicles since they produce only water and heat. Low-temperature fuel cells (80°C) are readily accessible in commerce, while high-temperature fuel cells (160°C) are presently being extensively researched by both academia and industry [92-95].

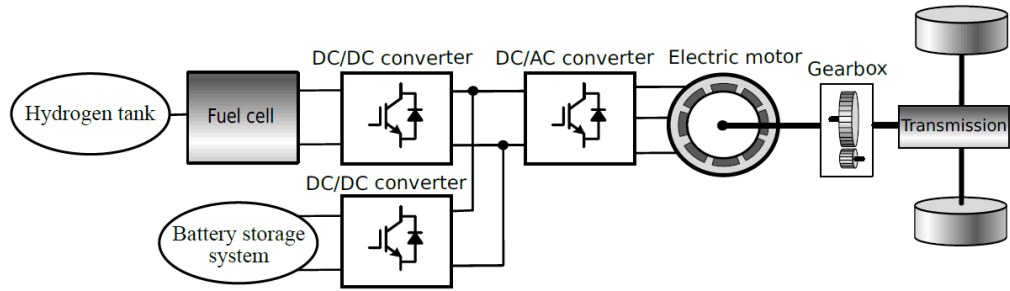

Figure 3.3. The diagram of fuel cell electric vehicles [87].

Combined mode, which utilizes both fuel cell and battery to provide average and peak power to the EV, respectively. Split mode, where the fuel cell propels the vehicle and charges the battery simultaneously, Thus, in regenerative mode, the kinetic energy generated during vehicle braking is utilized to charge the battery.

3.1.3 Internal Combustion Engine

The internal combustion engine (ICE) is a type of heat engine that converts the chemical energy of fuel into kinetic energy for vehicle propulsion. Natural gas, gasoline, diesel, and fuel oil are the main sources of fuel for ICEs, but they also use renewable fuels like biodiesel and bioethanol, frequently in conjunction with fossil fuels. Hydrogen, a less common fuel, is predominantly obtained from non-renewable sources (grey hydrogen) rather than renewable energy resources (green hydrogen) [96-100].

3.1.4 Hybrid and Plug-In Hybrid Vehicles

A hybrid electric vehicle (HEV) is an automobile that incorporates an additional form of reversed energy storage, including hydraulic, pressure, kinetic, or electrochemical storage spaces. along with its main power resource, which is the chemical power of the fuel. For the operation of the wheels, an HEV typically incorporates an electric motor, battery energy storage equipment, and an ICE [101-103]. In a series hybrid vehicle, as shown in Figure 3.4 (a), the ICE typically provides average power, while the energy storage device handles power peaks [104-106]. In a parallel hybrid configuration as shown in Figure 3.4 (b), the ICE functions

similarly to that of a conventional vehicle, providing power to the wheels). The engine is mechanically coupled to an electric motor that can assist it. In consideration of the vehicle's structure and design, the mechanical coupling can take the form of either a torque addition coupling or a speed addition mechanism. The parallel-series hybrid vehicle as shown in Figure 3.4 (c) integrates both principles presented earlier.

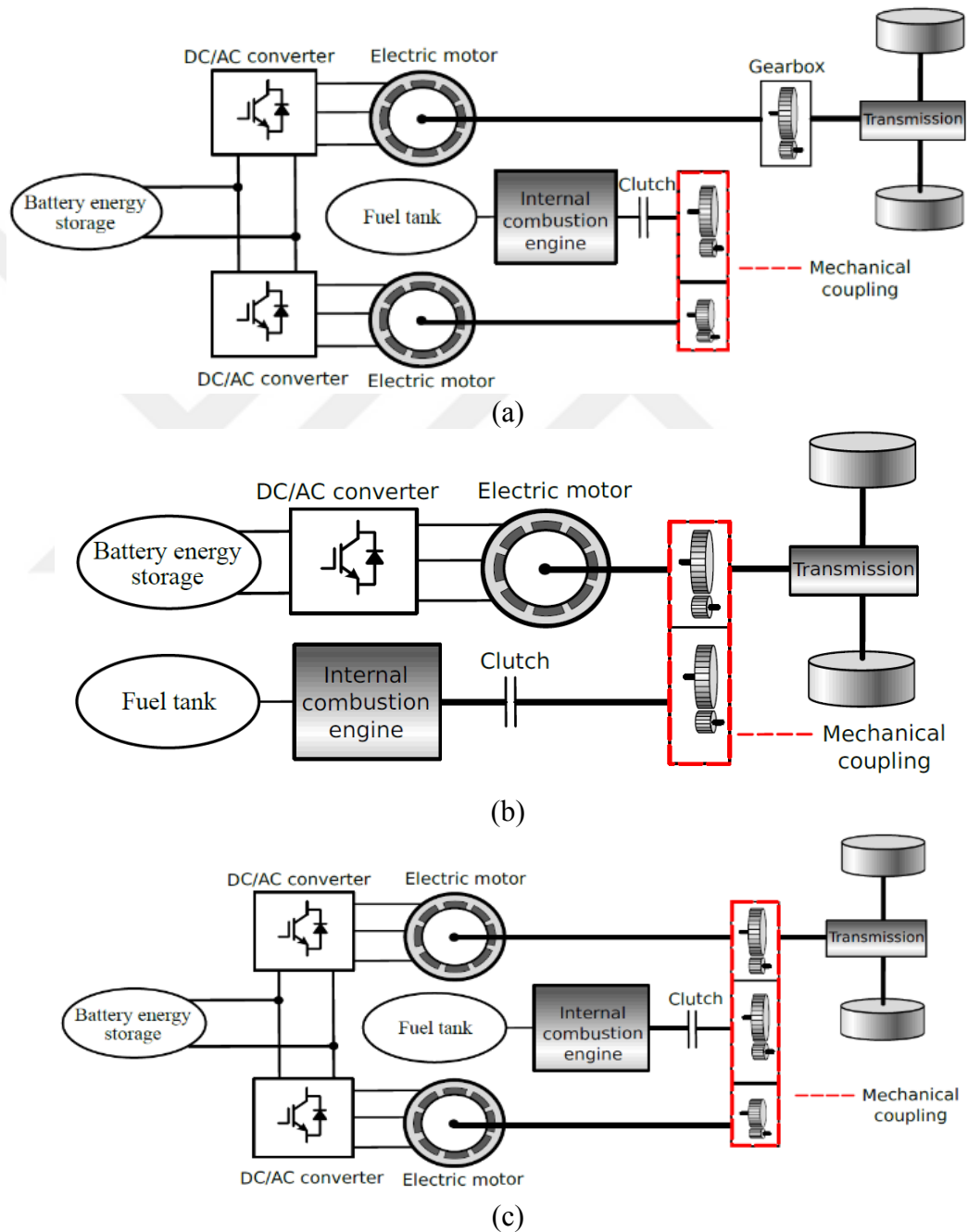

Figure 3.4. The diagram of full hybrid EV classification. (a) Series hybrid EV, (b) Parallel hybrid EV, (c) Parallel-series hybrid EV [87].

3.2. EV INTEGRATION INTO THE LOW VOLTAGE DISTRIBUTION

When an electric vehicle (EV) is connected to the low voltage network for charging, it becomes both a load and an integral component of the power systems. The widespread integration of EVs into existing power infrastructures can precipitate novel challenges, primarily because most current power grids were not originally designed to accommodate substantial EV charging demands.

Critical issues stemming from this include voltage underperformance and equipment overloading, which can consequently reduce the operational lifespan of essential grid components, such as substation transformers [107-110]. Moreover, the introduction of higher-capacity charging systems exacerbates these issues, as these chargers impose a more significant impact on the electrical power systems.

This is due to the high variability in load that these systems introduce, with the EV charging demand fluctuating more abruptly over shorter durations. Hence, a comprehensive understanding of the various charging technologies, modes, and connectors is imperative for the effective integration of EV chargers into the power grid, ensuring both stability and efficiency in energy distribution systems. Until recent times, there was a minimal interplay between the transportation and electric power sectors.

The widespread integration of EVs into the transportation landscape has substantially disrupted the conventional business models of electric utility providers [108-112]. As a result, the advent of EVs has introduced a dynamic interplay of significant challenges and considerable benefits to the power grid (PG). Figure 3.5 illustrates the impacts of EV PG-interfaced.

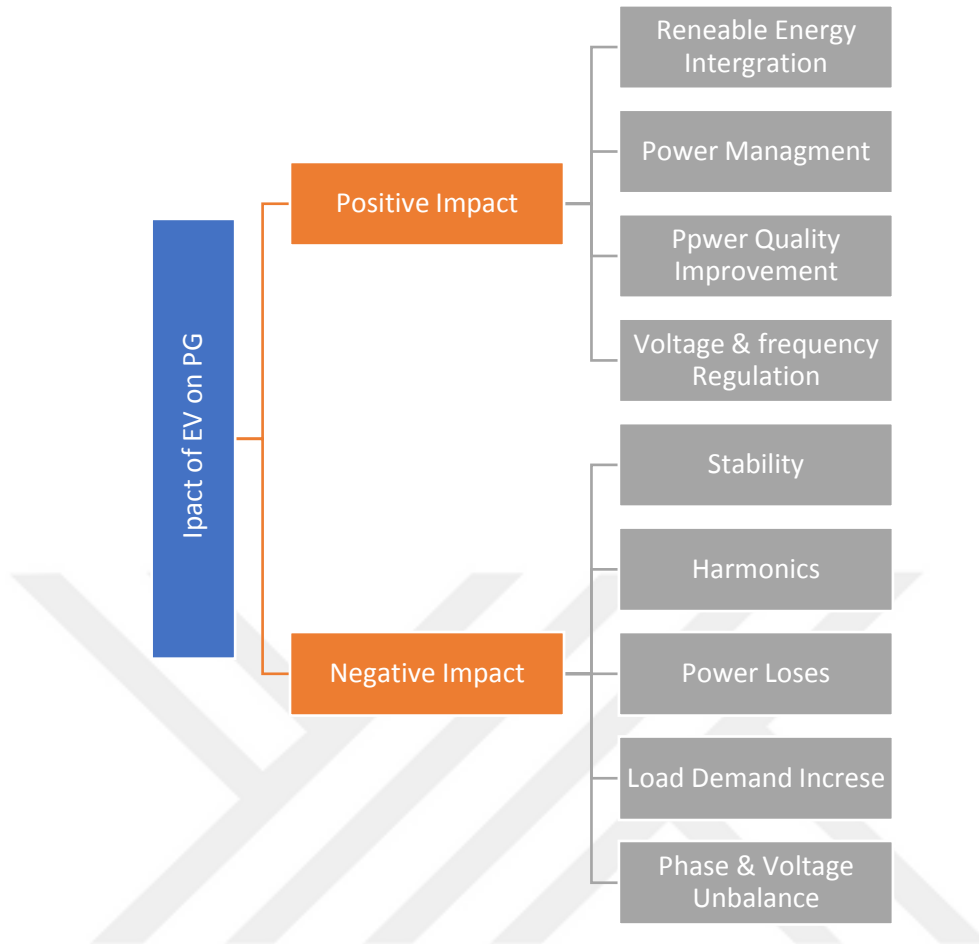

Figure 3.5. Impacts of EV distribution grid-interfaced.

EVs represent a significant challenge for electric utilities. Excessive integration of EVs into the distribution network can impact the load profile, distribution system component capacity, voltage and frequency imbalances, excessive harmonic injection, power losses, and the stability of the distribution grid as summarized in Table 3.2.

Although excessive EV penetration in the grid can create issues like power quality degradation, rise in peak load, and power regulation problems, all these issues can be resolved using advanced power management techniques. In Table II, the positive impacts of EV integration on the distribution grid (DG) in a coordinated environment are summarized.

Table 3.2. Negative impacts of EV PG-interfaced [113-119].

Impacts	Description
Stability	16. EV loads exhibit nonlinearity and demand a substantial power surge within a brief timeframe, thereby inducing instability within the power system.
Phase & voltage unbalance	17. The utilization of single-phase EV chargers has the potential to generate phase imbalances, particularly when a significant quantity of EVs is charged concurrently through the same phase.
Harmonics	18. EV chargers, being power electronic devices, produce harmonics during the process of power conversion. Consequently, when the penetration of EV chargers is elevated, these harmonics can contribute to harmonic pollution within the PG interface.
Load demand increase	19. Unregulated EV charging exacerbates peak-hour loads, posing a substantial challenge for utility companies.

Table 3.3. Positive impacts of EV DG-interfaced [120-124].

Impacts	Description
Power quality improvement	20. Reactive power injection can be regulated as needed. The harmonics by unregulated Distributed Energy Resources (DERs) can be mitigated.
Renewable energy Integration	21. The variability inherent in renewable energy sources can be effectively mitigated through the utilization of electric vehicles (EVs) as energy storage systems.
Regulation	22. Frequency regulation by correcting grid frequency deviation. 23. Voltage regulation by supplying/absorbing reactive power.
Power management	24. By using scheduled charging/discharging, better power management can be achieved.

3.3. CHARGING INFRASTRUCTURE

Although a significant portion of the current charging demand is effectively addressed through home charging solutions, the escalating requirement for publicly accessible charging stations has become increasingly pronounced. This shift is crucial to ensure that EVs match the convenience and accessibility standards of conventionally fueled vehicles. This transition is particularly imperative in densely

populated urban areas, where limited access to home charging facilities prevails [125,126]. In such contexts, the establishment of public charging infrastructure plays a pivotal role in expediting the adoption of EVs. As of the conclusion of 2022, the global count of public charging points has reached an impressive 2.7 million, with over 900,000 of these being newly installed within the same year. This surge reflects a notable 55% increase relative to the stock in 2021, aligning closely with the pre-pandemic growth rate observed between 2015 and 2019, which stood at 50%. This evolution underscores the vital role played by public charging networks in accommodating the soaring demand for EVs and sustaining their upward trajectory in popularity [127-130].

3.3.1. Slow Charging

On a global scale, over 600,000 public slow charging points were deployed in the year 2022, with a substantial portion of 360,000 being established in China. This influx elevates China's collection of slow chargers to surpass the remarkable 1 million mark, firmly positioning it as the predominant hub for public slow chargers across the globe. As of the conclusion of 2022, more than half of the worldwide inventory of public slow chargers was located within China [131,132]. Following China's lead, Europe emerges as the second-largest contributor in the realm of public slow-charging infrastructure. In the year 2022, Europe bolstered its total slow charger count to 460,000, signifying an impressive 50% surge compared to the preceding year. The Netherlands spearheads this movement with an admirable 117,000 slow chargers, while France and Germany follow with approximately 74,000 and 64,000 respectively. Conversely, the United States witnessed a more modest 9% expansion in its slow charger inventory in 2022, marking the lowest growth rate among major markets. In Korea, however, the pace of progress has been notably more rapid, doubling the stock of slow chargers on a year-on-year basis to achieve a commendable count of 184,000 charging points [133,134].

3.3.2. Fast Charging

Publicly accessible rapid chargers, particularly those strategically positioned along highways, play a pivotal role in facilitating extended journeys and effectively mitigating range anxiety, a prevalent concern that has historically hindered the widespread embrace of EVs. Much like their slow-charging counterparts, public fast chargers extend charging solutions to individuals who lack reliable access to private charging infrastructure. This inclusive approach serves to propel EV adoption across a broader spectrum of society. In the year 2022, the global count of fast chargers witnessed an augmentation of 330,000 units. It's worth noting that a substantial proportion, almost 90%, of this expansion emanated from China [135,138]. This fast-charging boom holds significance as it effectively addresses the challenge of limited home charging access, particularly in densely populated urban centers. Moreover, this aligns seamlessly with China's ambitious agenda for swift EV proliferation [139-141].

3.4. CHARGING STATIONS

In light of the burgeoning expansion of the electric vehicle (EV) market, encompassing both fully electric and plug-in hybrid models, the imperative for a dependable and secure recharging infrastructure that adequately accommodates user requirements has become increasingly critical [142-145]. To catalyze the broad-scale adoption of EVs, it is crucial to establish a comprehensively distributed recharging network. There are three principal technologies for EV charging: conductive charging, inductive charging, and battery swapping, each of which is delineated in Figure 3.6. These technologies represent the foundational elements necessary to support the transition towards widespread electric mobility, ensuring accessibility and convenience in recharging operations.

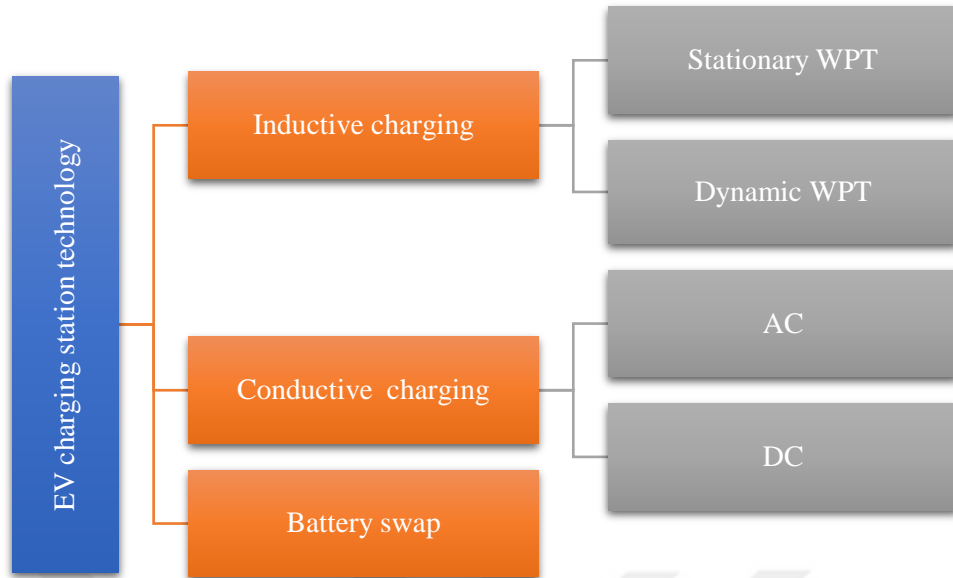

Figure 3.6. Three primary types of EV charging technologies.

Wireless Power Transfer (WPT) systems, tailored for stationary applications, have showcased the capacity to facilitate rapid charging rates up to 50 kW, thereby diminishing the charging duration for electric vehicles (EVs) to a mere 15-20 minutes. Conversely, these systems are also capable of delivering slower charging outputs of up to 3 kW over extended periods ranging from 4 to 8 hours. Moreover, dynamic WPT technology enables the continuous charging of EVs in motion, thus permitting energy replenishment during travel [146-148].

Within the broader spectrum of charging technologies, AC conductive charging presents a versatile array of speeds: fast charging (Level 3) can achieve up to 43 kW with 3-phase power within 15-30 minutes, intermediate charging (Level 2) up to 22 kW with 3-phases over 1-3 hours, and slow charging (Level 1) at 3.6 kW with a single phase extending across 6-8 hours. Alternatively, DC conductive charging, also recognized as Level 3 charging, is formidable in its capability, delivering up to 400 kW at 1000V and enabling exceptionally swift recharging times of 15-20 minutes [149-152].

In addition to these methods, battery swapping represents an alternative charging technique, involving the exchange of a depleted battery for a fully charged one, typically accomplished within approximately five minutes. This method offers a

rapid solution to energy replenishment, catering effectively to users requiring immediate battery replacement.

3.4.1. Electric Vehicle Supply Equipment

Electric Vehicle Supply Equipment (EVSE) constitutes a critical infrastructure component that delivers electrical energy to the batteries of electric vehicles (EVs). It encompasses a variety of elements, including electrical power conductors, charging ports, protective devices, alongside sophisticated software and communication systems that facilitate efficient and secure electricity delivery for recharging EV batteries [153,154]. Furthermore, the EVSE enables interactive communication between the EV and the charging facility, orchestrating the dynamic exchange between the charging station and the electric grid.

Regulatory standards and codes are pivotal in governing the EVSE, specifically delineating the connectivity protocols between the EV and EVSE, as well as between the EV and the power grid. In this regard, the SAE J1772 standard predominates in North America, whereas the IEC 61851/62196 standards are primarily adopted in Europe and other burgeoning markets [155,156].

AC charging leverages electricity directly from the grid, with the EVSE's role confined to monitoring and regulating power flow to ensure operational safety, depicted in Figure 3.7. Table 3.4 outlines the variations in symbols, connectors, charging modes, and standards across different countries, illustrating the global diversity and regulatory compliance in EV charging infrastructure.

3.4.2. EV Charging Modes and Charging Stations Level

Three primary charging modalities are utilized for electric vehicles, specifically: conductive charging, inductive charging, battery swapping, and wireless charging. These modalities play a pivotal role in facilitating the broad adoption of electric vehicles. Conductive charging, the predominant method, necessitates the utilization of a cable to establish a connection between the Electric Vehicle Supply Equipment

(EVSE) and the electric vehicles [157-159]. This mode is essential for integrating EVs into existing electrical infrastructure and consumer usage patterns.

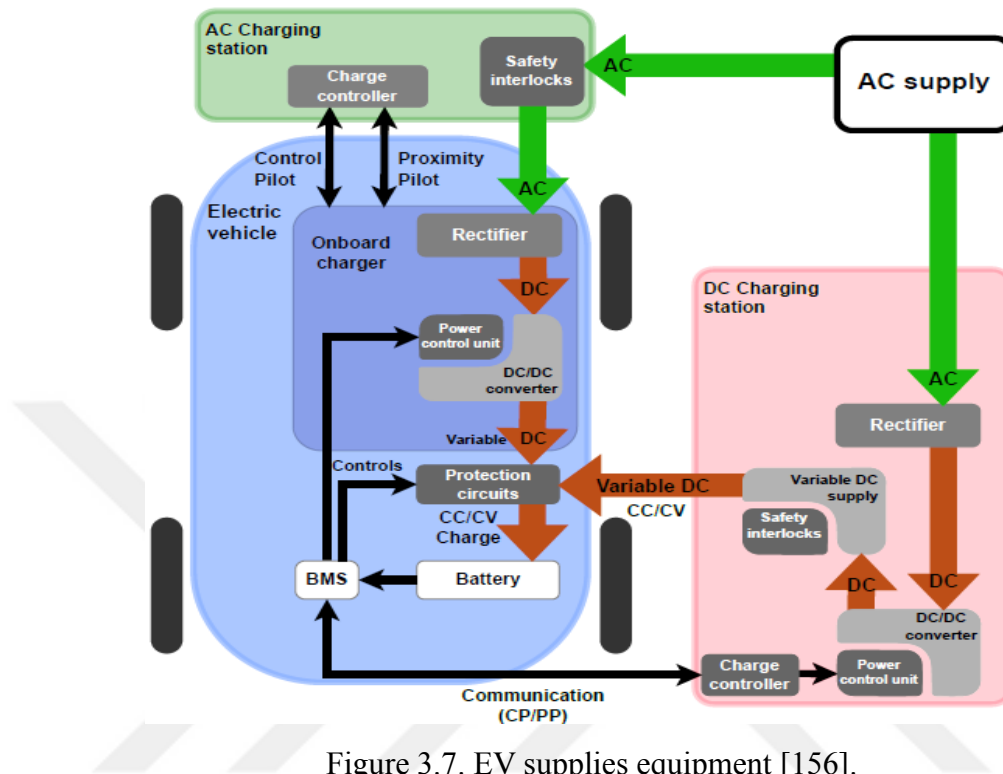









Figure 3.7. EV supplies equipment [156].

Table 3.4. Different countries, symbols, connectors, charging modes, and standards of EVs [155,156].

Country	Symbol	Connectors	Charging Modes	Standards
USA		Type 1/j1772	AC	IEC 62196
Japan				SAE j1772
China		GB/T	DC	GB/T 20234
UE		CSS/Combo	DC	DIN SPEC 70121
USA				
Tesla (EU)		Type 2/Mennekes	DC	IEC 62196
EU		Type 2/Mennekes	AC	GB/T
China		Type 2/Mennekes	AC	IEC 62196

3.4.3. Conductive Chargers

Conductive chargers, which facilitate the electrical recharging of batteries in electric vehicles, are delineated into two categories: on-board and off-board. On-board chargers, utilizing alternating current (AC) from the grid, are confined by their physical dimensions and deliver relatively modest power due to the necessity of accommodating AC/DC conversion within the vehicle itself [160]. This setup may permit the utilization of the vehicle's traction energy conversion system for the charging process. In contrast, off-board chargers are direct current (DC) systems that provide higher output power and enhanced flexibility in power supply management. Conductive charging stations, based on the power output and system type, are systematically classified into three distinct levels: Level 1, Level 2, and DC rapid chargers, each offering different charging capabilities and speeds [162,163].

3.4.4. Inductive Charger

The inductive charger operates as a wireless power transfer (WPT) system that enables the recharging of electric vehicle (EV) batteries through electromagnetic induction. This method is implemented in two distinct configurations: stationary charging, which occurs when the EV is parked, and dynamic charging, facilitated while the EV is in motion with an embedded charging apparatus integrated into the roadway infrastructure [164]. Wireless charging represents an innovative resolution to the complexities posed by the heterogeneity of charging ports, which vary widely in configuration, shape, and size across different countries and EV manufacturers. Employing this technology standardizes the charging process, obviating the need for conventional cables [165-167].

3.4.5. Battery Swapping

Battery swapping is an alternative charging method that entails the replacement of a depleted battery with a pre-charged, identical one. This process involves the vehicle entering a designated battery switch bay where an automated mechanism adjusts the vehicle's position, extracts the spent battery, and installs a fully charged counterpart.

The depleted batteries are then recharged within the facility for subsequent use. Predicated on a business model wherein the electric vehicle (EV) owner possesses the vehicle but not the battery, battery swapping offers a rapid charging solution, akin in duration to refueling a conventional internal combustion engine vehicle. However, this method confronts substantial logistical challenges, particularly the need for standardized battery interfaces across various EV manufacturers, which complicates widespread adoption and implementation [168-170].

3.4.6. Wireless Charging

Wireless charging for electric vehicles (EVs) employs galvanic isolation to separate the input and output circuits, ensuring a safe transfer of power. Historically utilized in low-power applications, recent innovations in power electronics and the development of advanced semiconductor materials have now facilitated higher power capacities for wireless power transfer, rendering it a feasible method for EV charging. This technology offers several distinct advantages over conventional wired charging systems. First, it provides a streamlined, safe, and user-friendly charging experience, requiring minimal maintenance due to the absence of mechanical components. Second, it eliminates hazards associated with traditional cables, such as the dangers of using deteriorated cables under wet or icy conditions, by ensuring galvanic isolation between the vehicle and the power source. Third, the charging apparatus can be embedded beneath the surface, which shields it from adverse environmental conditions, enhances the longevity of the charging infrastructure, and reduces the risks of vandalism, including cable theft or damage to external components [171-173].

3.5. CHAPTER SUMMARY

This section provides a theoretical analysis of grid-connected electric vehicles (EVs), focusing on various facets of EV integration into the low voltage distribution system, the current status of electric vehicles, and the battery technologies used in EVs. Additionally, the chapter explores the charging infrastructure, distinguishing between slow and fast charging methods.

PART 4

METHODOLOGY

4.1. INTRODUCTION

This chapter expounds upon the selected methodology employed in the present thesis, encompassing a comprehensive depiction of the research approach and process, as well as the designation of the preferred data sources and modelling technique. Certainly, the selected methodology is a critical component of any research endeavor since it outlines the systematic and logical approach utilized to achieve the research objectives. In this chapter, the research approach and process are elaborated upon, providing a detailed account of the methods and techniques employed to collect, analyses, and interpret the research data. Furthermore, the chosen data sources are identified, highlighting their relevance and suitability for the research objectives. Additionally, the modelling method employed in the research is elucidated upon, providing a comprehensive explanation of the techniques utilized to develop and test the research hypotheses. The methodology chapter is a crucial aspect of any research project as it enables the reader to comprehend the research design, data collection, and analysis procedures utilized, thereby enhancing the credibility and validity of the research findings.

4.2. RESEARCH FLOWCHART

The primary objective of this thesis is to investigate and analyses the potential implications of electric vehicles on low-voltage grids. This research study aims to develop low voltage distribution grid models in the NEPLAN PROGRAM that incorporate asymmetric load-flow simulations, accounting for factors such as household load variations, car home arrivals, and different state-of-charge scenarios.

The research work further seeks to evaluate the outcomes of these simulations. Specifically, the investigation focuses on a large residential area comprising 72 houses, from which a low voltage grid model is created to facilitate the requisite simulations, including load flow analysis and time. The structured flowchart provides a clear roadmap for your thesis work, ensuring a systematic approach to analyzing the influence of EVs on the electrical distribution network as indicated in Figure 4.1.

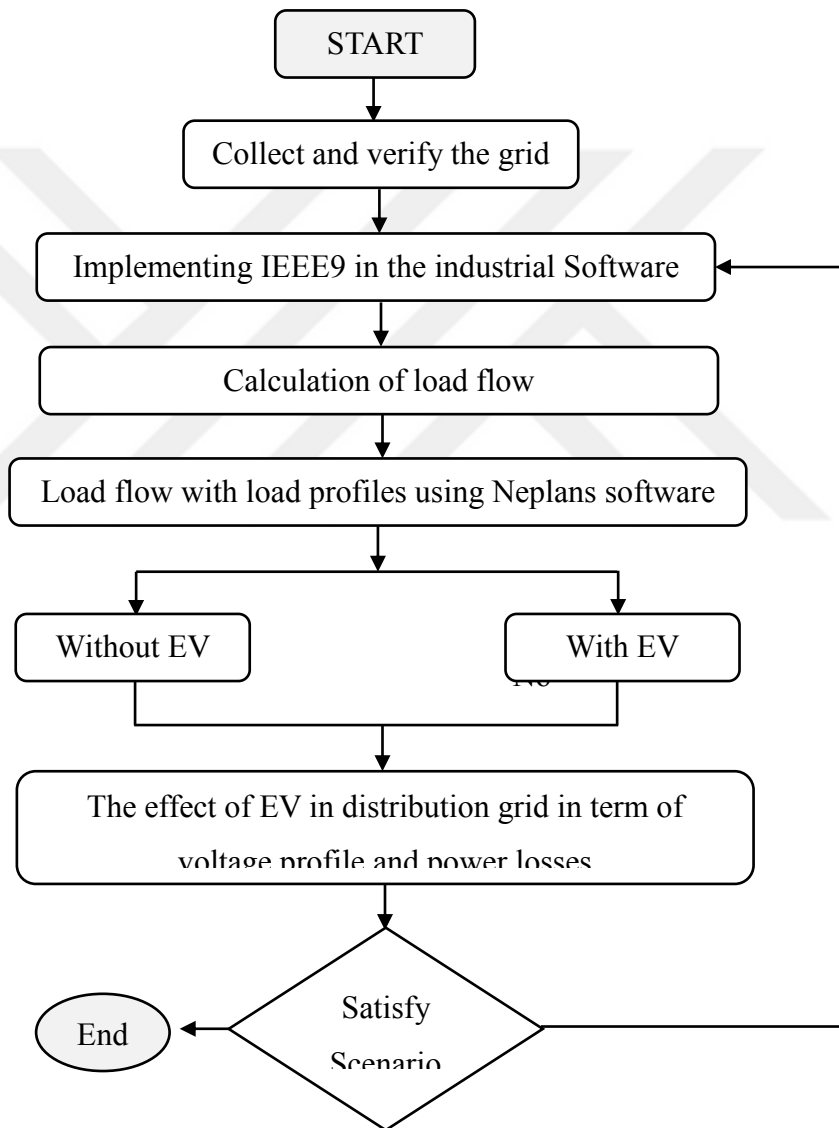

Figure 4.1. The flowchart of the impact of EVs in the distribution Network's voltage profile and Energy losses.

The flowchart for analyzing the impact of EVs on the voltage profile and energy losses within a distribution network involves a structured approach to data collection, software implementation, and simulation. Here's a detailed description of each step in the flowchart for your thesis work:

- Collect and Verify Grid Data:

Objective:

- Gather all relevant data regarding the distribution network to ensure accuracy in simulations.

Actions:

- Collect grid topology, load data, transformer capacities, and line impedances.
- Verify the accuracy and completeness of collected data to avoid errors in the model.
- Implement IEEE 9 Bus System Using Industrial Software:

Objective:

- Set up a standard model that can serve as a baseline for further simulations.
- Actions:
- Utilize a software industrial-grade tool to implement the IEEE 9 bus system.
- Configure the software settings to align with the specific parameters of the distribution network being studied.
- Simulation Setup in Neplan Software:

Objective: Prepare the Neplan software environment for detailed load flow analysis.

Actions:

- Import the verified grid data into Neplan.

- Set up the simulation environment corresponding to the IEEE 9 bus system adapted for the specific network characteristics.
- Load Flow Analysis with Load Profiles Using Neplan:

Objective:

- Conduct a comprehensive load flow analysis to evaluate the network's performance under different scenarios.

Actions (without EVs):

- Run simulations to establish a baseline of the network's voltage profile and energy losses without the impact of EVs.
- Analyze and document the results as the control scenario.

Actions (with EVs):

- Integrate EV load profiles into the simulation, representing various levels of EV penetration.
- Simulate the network's behavior with the additional loads imposed by EV charging.
- Analyze how EV integration affects voltage stability and energy losses compared to the baseline scenario.
- Comparison and Analysis:

Objective:

- Compare the results from both scenarios to assess the impact of EVs on the distribution network.

Actions:

- Use graphical and statistical tools within Neplan to compare voltage profiles and quantify energy losses.
- Identify patterns, anomalies, or critical issues that arise from the integration of EVs into the network.
- Documentation and Reporting:

Objective:

- Compile the findings into a comprehensive report that outlines the methodologies, results, and conclusions.

Actions:

- Document each step of the process, including assumptions made, challenges encountered, and solutions implemented.
- Prepare detailed charts, graphs, and tables to visually represent the impact of EVs on the network.
- Conclude with recommendations for managing voltage profiles and minimizing energy losses in networks with high EV penetration.

To summarize, the thesis work on evaluating the impact of electric vehicles (EVs) on a distribution network's voltage profile and energy losses follows a structured and systematic approach. The process begins with the collection and verification of relevant grid data, ensuring the accuracy of the model. Using industrial software, the IEEE 9 bus system is then implemented to provide a standard baseline for simulations. The Neplan software is utilized to set up and conduct detailed load flow analyses under two scenarios: with and without EV integration. This involves simulating and analyzing the network's behavior to identify how EV charging affects voltage stability and energy losses compared to the baseline scenario without EVs. Results from both scenarios are compared to assess the impact of EVs. Finally, the findings are documented comprehensively, providing insights and recommendations for managing the challenges posed by high EV penetration in the network. This

methodical approach ensures a thorough understanding of the dynamic interactions between EVs and the power grid.

4.3. RESEARCH PROGRESS

The reason for this research topic is the interest in the chargeable electric vehicles (EVs) which is growing in number very rapidly and to know the impact they can have on low-voltage grids. That's why we have firstly defined the problems what objectives we have as stated above, then structured the problems like we have added some households loads and EV and analyze the load flow and time sweep analysis to find out the loading on transformer, variations in voltage, current, etc. across each load and EVs.

4.4. COLLECTION OF DATA

In accordance with the aforementioned, a critical component of this thesis involves the collection of relevant data. To obtain precise insights into the potential impacts of charging electric vehicles (CEV) on the network grid, it is imperative to accurately determine the expected number of electric vehicles in the future, their intended usage locations, and their corresponding technical specifications. Such information is indispensable for ensuring the robustness and accuracy of the research outcomes. Determining EV integration is a very difficult and time-consuming task. Researcher interfaced network grid with number of household loads and an EV load, that is, in this case 72 household loads and 40 EVs.

4.5. THE INVESTIGATION OF DISTRIBUTION GRID

In the present study, the local electric distribution grid was investigated to acquire relevant data for the research. The aim was to comprehend the grid's components and their interactions, as well as the overall functioning of the grid. The researcher sought to understand the grid's construction, and how its various components, such as transformers and cables, contribute to its operation. Additionally, the researcher analysed the current load on the grid and explored how it might change in the future.

Understanding these aspects of the grid is crucial for accurately modeling and simulating its performance under different scenarios.

4.5.1. Phase Allocation

The household loads in the grid operate as single-phase loads, drawing power from a 230V line-to-ground electrical system. Due to the distribution of loads across different phases, voltage asymmetry is expected to occur within the network grid. Notably, if all consumers were three-phase loads, no asymmetry would be observed. However, the introduction of EV chargers into the network grid serves as the primary source of asymmetry.

4.5.2. Distribution Grid Parameters

The electrical distribution grid parameters, such as cable resistance and reactance, remain unknown to the researcher. As a result, the NEPLAN Software's built-in cable, transformer, and other relevant types were utilized, as they contain all the requisite information. A transformer with a nominal power of 1 MVA was employed in the simulations.

4.5.3. Power Factor of Loads

The power factor serves as a critical indicator of the efficiency of electricity utilization. In the present study, the power factor was set at 0.9 for household loads and 1 for electric car loads. It is important to note that the power factor is subject to change with variations in loads.

4.6. DISTRIBUTION GRID IMPLEMENTATION

This subsection expounds upon the parameters of the selected distribution grid, as well as the modeling of the distribution grid in the Neplan software. Additionally, it provides a detailed account of the designated data, such as active power and power factor for both household loads and electric car loads. In addition, the selected

transformer for the simulation possesses a nominal power of 1MVA. Additionally, the length and cross-sectional area of the cables were predetermined. The XLPE-3.5CX240 0.4kV and XLPE-3.5CX95 0.4kV built-in cables were utilized, with the neutral connected. In this regard, the low voltage distribution grid is connected to an external grid with an 11kV line-to-line connection via the aforementioned transformer. The supply area of the transformer has been modeled in the simulation.

4.7. NEPLAN PROGRAM

NEPLAN is a software program utilized for power system analysis and planning. It is designed to facilitate the modeling and simulation of electrical networks, including load flow analysis, fault analysis, and optimization. NEPLAN offers a comprehensive set of tools for analyzing power systems, enabling researchers to evaluate the performance of electrical grids under different conditions and scenarios. The software also provides a range of features for modeling and simulating renewable energy systems, allowing researchers to investigate the integration of renewable energy sources into existing power systems. NEPLAN is widely used in both academic and industrial settings for power system planning and analysis.

The NEPLAN software environment bears many similarities to other parallel software programs, such as ETAP and Digsilent. Users proficient in power system analysis can readily navigate and operate the software with ease. The software's robust capabilities for performing a wide range of analyses, coupled with the accuracy and precision of its output data, and the availability of diverse analysis tools, have rendered it a popular choice for analyzing and simulating power networks. Currently, over 2,000 individuals across 90 countries are developing and utilizing NEPLAN for power system analysis and planning. NEPLAN offers a multitude of features and capabilities for power system analysis and planning, including:

- Load flow analysis: NEPLAN can perform load flow analysis for both steady-state and dynamic conditions, enabling researchers to evaluate the performance of electrical grids under different scenarios.

- Short-circuit analysis: The software can simulate various types of faults in electrical networks, providing researchers with insights into fault currents and other relevant parameters.
- Optimization: NEPLAN offers optimization tools for power system planning, enabling researchers to determine the most cost-effective and efficient solutions for grid design and operation.
- Renewable energy integration: The software can model and simulate renewable energy systems, allowing researchers to investigate the integration of renewable energy sources into existing power systems.
- Graphical user interface: NEPLAN offers a user-friendly graphical interface, making it easy to navigate and operate the software.
- Customization: The software can be customized to meet specific research needs, with the ability to add custom modules and features.
- Data management: NEPLAN includes comprehensive tools for managing and visualizing power system data, facilitating the analysis and interpretation of simulation results.
- Multi-language support: The software supports multiple languages, enabling researchers from different countries and regions to utilize the program.

In conclusion, NEPLAN offers a range of powerful features and capabilities for power system analysis and planning, including load flow analysis, short-circuit analysis, optimization, renewable energy integration, a graphical user interface, customization, data management, and multi-language support. These features have made NEPLAN a popular choice among researchers across the globe, enabling them to model and simulate power systems with accuracy and precision.

PART 5

RESULT AND DISCUSSION

5.1. THE PARAMETER OF THE PROPOSED SYSTEM MODELING OF GRID-CONNECTED EV

This subsection delves into the detailed parameters of the proposed system for modeling grid-connected electric vehicles (EVs). As the integration of EVs into the power distribution networks continues to grow, understanding the specific parameters that influence system performance becomes crucial. Table 1.5 indicates the parameter of the proposed system.

Table 5.1. The parameter of the proposed system [168-173].

System quantities	Rating
Grid supplying two distribution feeders	115Kv, X/R ratio=6
Short circuit	500MVA
Line impedance	0.1529+j0.1406 ohm/km
Distance of line lines are 1km long	
TRM	115KV/12.47KV/20MVA
TR1, TR2, TR3, TR4, TR5, TR6, TR7, TR8	12.47KV/0.4KV 2MVA
Load Energy without EV	69.289 MWh
Load Energy with EV	82.38 MWh
Maximum Load without EV	4.722 MW
Maximum Load with EV	5.489 MW
Load Loss Factor without EV	0.4351
Load Loss Factor with EV	0.383
Energy Losses without EV	0.625 MWh
Energy Losses with EV	0.839 MWh
Maximum Losses without EV	0.059 MW
Maximum Losses with EV	0.0911 MW

In the context of the proposed system for modeling grid-connected electric vehicles (EVs), it is imperative to delineate the specific parameters that govern the dynamics of power distribution networks. As EV integration intensifies, a profound comprehension of these parameters becomes essential for evaluating system performance accurately. Notably, the grid in question is configured to supply two distribution feeders, each rated at 115 kV with an X/R ratio of 6, and a short-circuit capacity of 500 MVA.

Furthermore, the line impedance is specified as $0.1529 + j0.1406$ ohm/km, with all transmission lines extending for precisely 1 km. The main transformer (TRM) utilized within this configuration is rated at 115 kV/12.47 kV with a capacity of 20 MVA. Complementarily, additional transformers labeled TR1 through TR8 are configured at 12.47 kV/0.4 kV, each with a capacity of 2 MVA. These detailed specifications are critical for understanding the electrical characteristics and operational constraints of the network under the increased load conditions imposed by EV charging.

5.2. MODELING OF GRID-CONNECTED EV

The Neplan software program was employed, utilizing a model based on the 9-bus IEEE system Neplan software program as demonstrated in Figure 1. This tool allows for a precise simulation of how EVs interact with the power grid under various scenarios. The findings discussed herein provide insights into the potential challenges and efficiencies that can arise from high penetration levels of electric vehicles within and without urban distribution networks. The findings are critical for stakeholders in energy management and infrastructure planning to understand the dynamic changes introduced by EVs and effectively strategize for future grid enhancements.

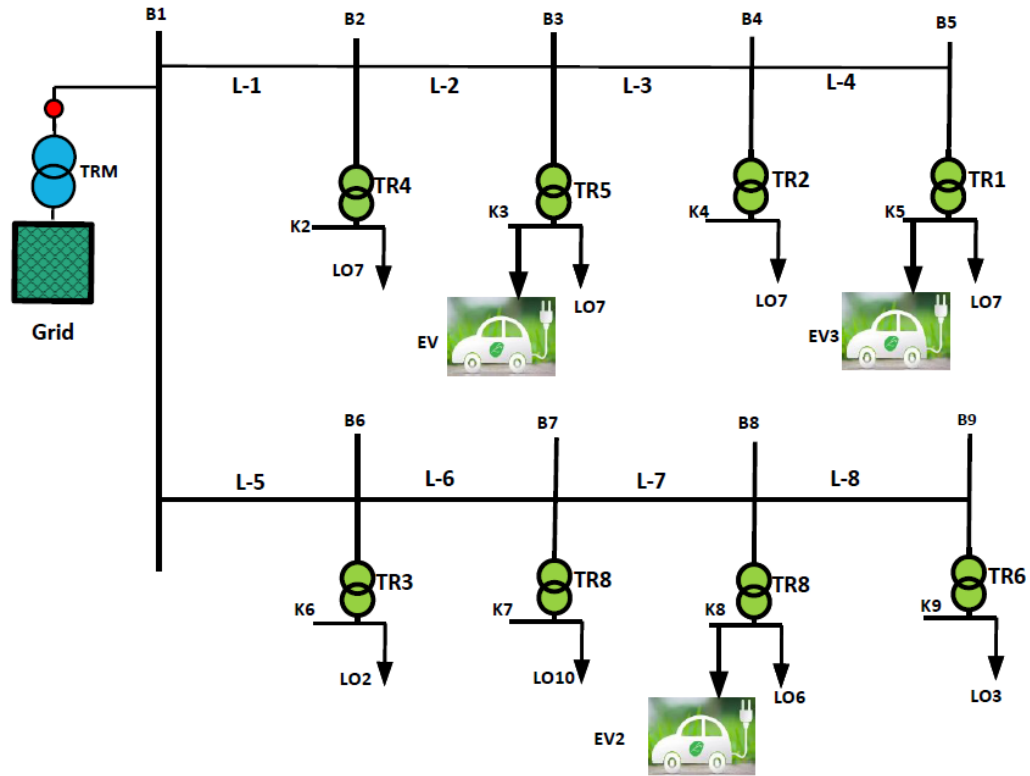

Figure 5.1. The diagram of proposed modeling using the Neplan software program.

The employment of the Neplan software in this analysis merits particular attention due to its robust simulation capabilities, as evidenced by its adoption of a model based on the well-established 9-bus IEEE system. This model features a single network feeder with a substantial capacity of 4.3 MW, which is integral for assessing the performance and reliability of the grid under high power loads. The complexity of the system is further highlighted by the inclusion of 11 distinct load points, each with varying demand loads, thus simulating a realistic diversity in consumer energy usage within the network. It is observed that the EV interfaces are connected with Bus 3, Bus 5, and Bus 8. Additionally, the infrastructure of the proposed model is enhanced by the integration of nine transformers, each designated as a 2W Transformer.

These transformers are critical components, designed to handle dual-winding operations that are essential for effective voltage regulation and efficient power distribution across different nodes of the network. The presence of 18 nodes within the model allows for an exhaustive analysis of the electrical flow and potential

bottlenecks or inefficiencies that may occur at various junctures within the distribution grid.

5.3. RESULT FROM MODELING OF GRID-CONNECTED EV

In the context of this thesis, a comprehensive network simulation incorporating a 72-household grid was executed using the NEPLAN software program. The simulation was meticulously designed to evaluate two distinct scenarios: one where no households possess EVs, and another where electric vehicles are present in 40 of the 72 homes. For each household, specific loads were configured to simulate the electrical consumption patterns both with and without the presence of EVs. Measurements were taken from various critical points within the network to assess the impact of these loads. Current readings were systematically recorded from the power transformer and network cables to monitor the flow and distribution of electricity across the grid.

Additionally, the thesis work involved detailed monitoring of power losses within the network, a key indicator of efficiency and network health. To further understand the dynamics of household electricity consumption, electrical energy usage data was collected over a continuous 24-hour period from each home. Voltage levels were also meticulously measured at the Puller Box, providing valuable insights into the stability and adequacy of voltage supply across the network.

This simulation elucidates not only the additional load and stress imposed on the grid by the integration of electric vehicles but also functions as an essential instrument for forecasting and addressing potential challenges in grid management and infrastructure development within residential contexts. By providing detailed insights into the effects of EV adoption on electrical networks, the simulation facilitates strategic planning and proactive measures to ensure the stability and efficiency of power distribution systems in residential areas.

5.3.1. VOLTAGE PROFILE ON DIFFERENT BUSES WITHOUT EV

Understanding the results of voltage levels at different buses without the presence of electric vehicles (EVs) is crucial for several reasons. Firstly, it establishes a baseline or control scenario against which the impact of EV integration can be measured. This baseline data is essential for identifying how the addition of EV loads affects the stability, capacity, and operational efficiency of the power distribution network. Secondly, knowing the voltage at different buses under normal conditions without EVs helps in assessing the adequacy of the existing infrastructure. Figure 5.2 presents the result of voltage on different buses without EV. Figure 5.3. The results of voltage range (%) on different buses without EV. Figure 5.4 shows the results of voltage range (%) of distribution's network transformer with EV. Figure 5.5, illustrates the results of bus voltages (P.U) of distribution's network with EV. Figure 5.6, presents the results of charging voltages (MW) of distribution's network with EV.

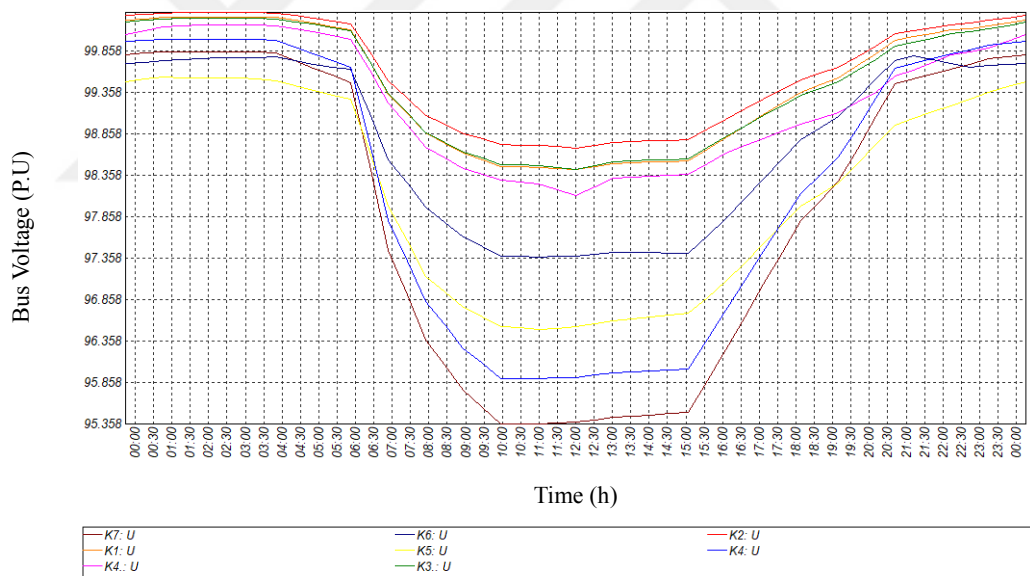

Figure 5.2. The result of voltage on different buses without EV.

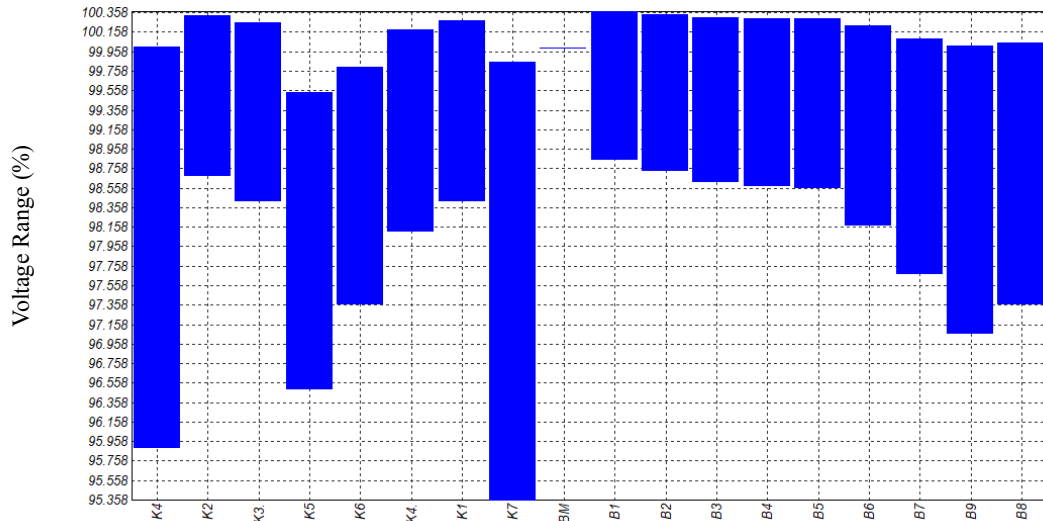

Figure 5.3. The results of voltage range (%) on different buses without EV.

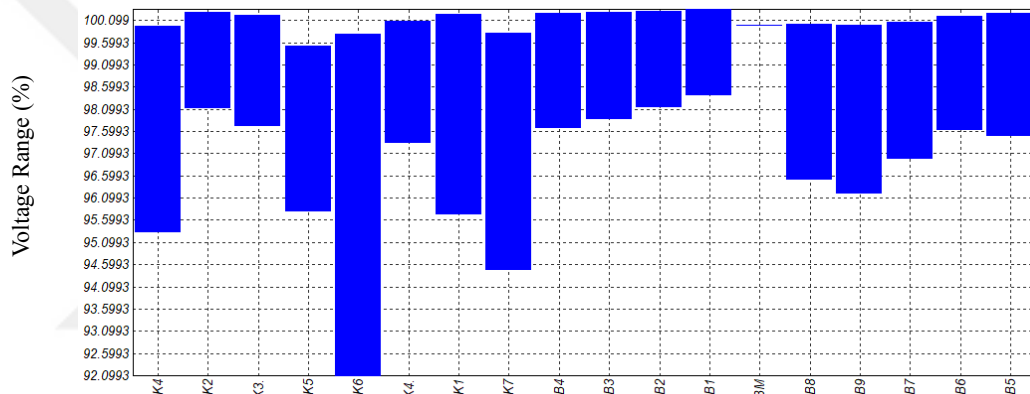

Figure 5.3. The results of voltage range (%) on different buses without EV.

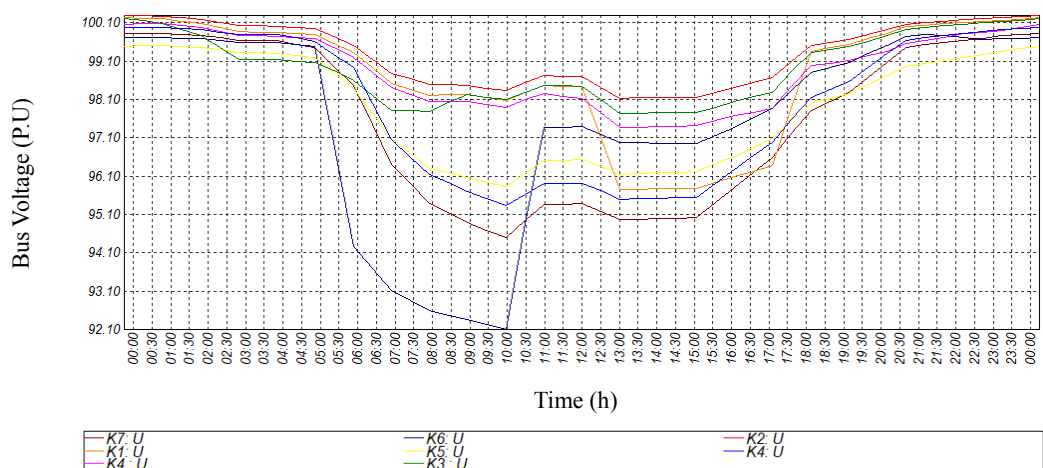

Figure 5.4. The results of voltage range (%) of distribution's network transformer with EV.

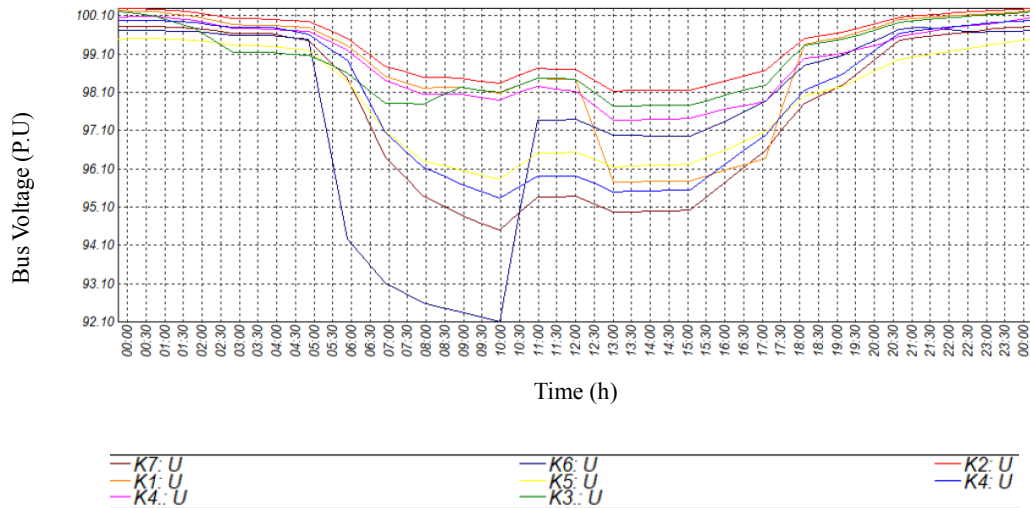

Figure 5.5. The results of bus voltages (P.U) of distribution’s network with EV.

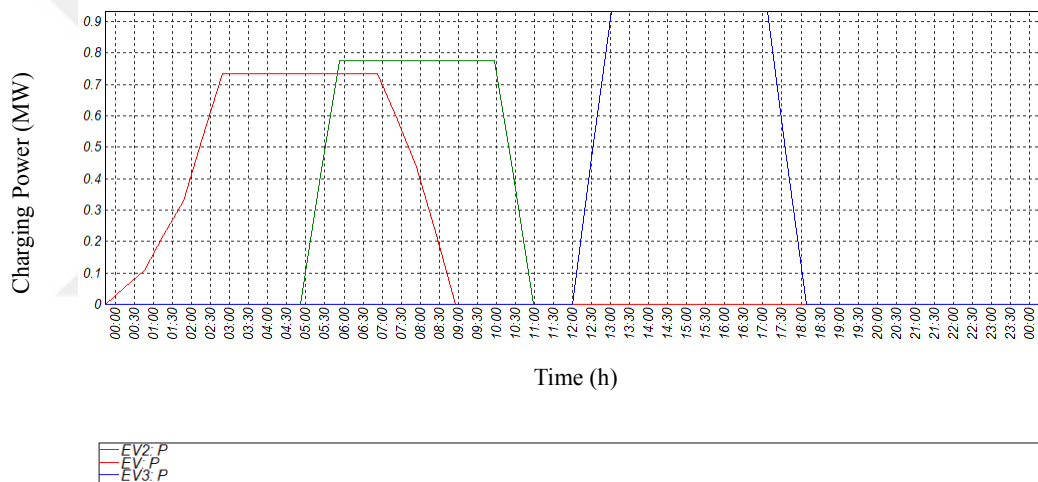

Figure 5.6. The results of charging voltages (MW) of distribution’s network with EV.

Additionally, analyzing voltage levels at various buses provides insights into potential weak points or vulnerabilities in the network. These could be areas where voltage levels are already near critical limits or where minor fluctuations could lead to significant issues, such as voltage sag or instability. Moreover, this analysis aids in the proactive planning of grid expansion and reinforcement. By understanding the baseline conditions, utilities can more effectively strategize where to invest in grid modernization, such as adding transformers, upgrading lines, or integrating advanced voltage control systems. In summary, understanding the voltage levels at different buses without EV loads is fundamental for ensuring grid reliability and efficiency as the penetration of electric vehicles increases. This knowledge not only supports the

maintenance of power quality and service reliability but also facilitates informed decision-making for future grid developments.

5.3.2. The Results of Real Power (MW) Generation

Discussing the results of real power (MW) generation during the modeling of grid-connected electric vehicles (EVs) is crucial for several integral aspects of energy management and infrastructure development. Figure 5.7, shows the results of obtaining Real Power (MW) based on generation. Figure 5.8, presents the results of Real Power loss (MW) with EV. Figure 5.9, presents the results of the Real power loss (MW) of the distribution network transformer with EV.

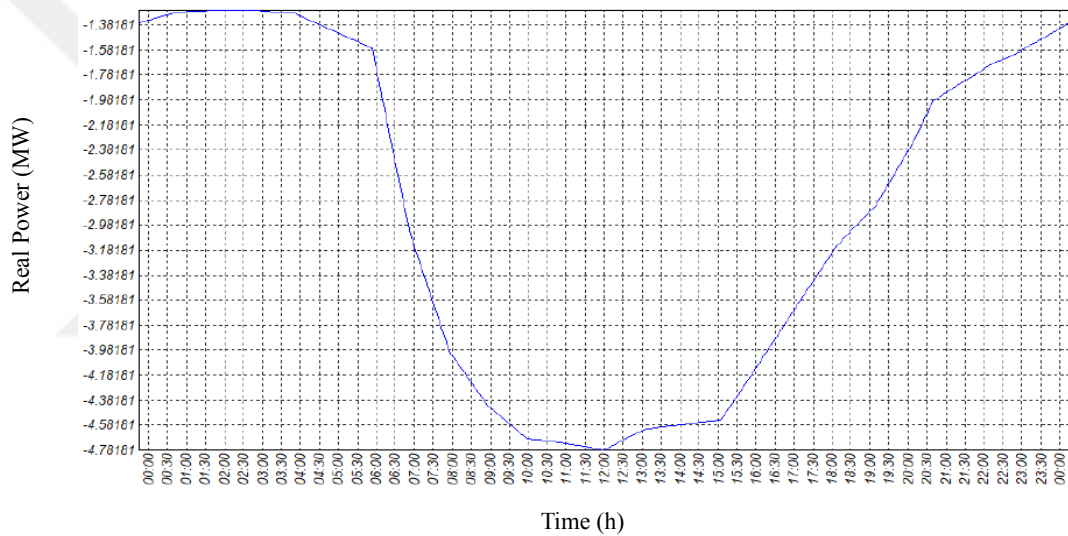

Figure 5.7. The results of obtaining (Real Power (MW)) based on generation.

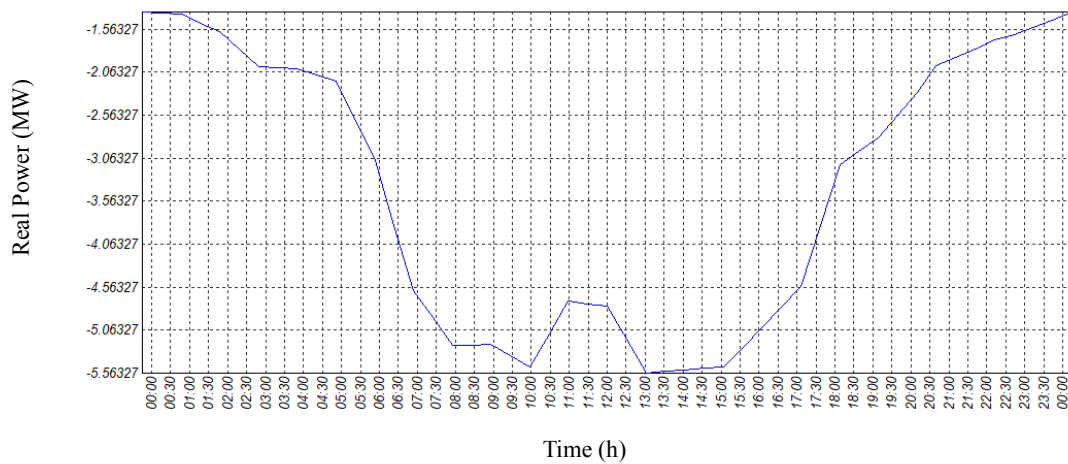

Figure 5.8. The results of Real Power loss (MW) with EV.

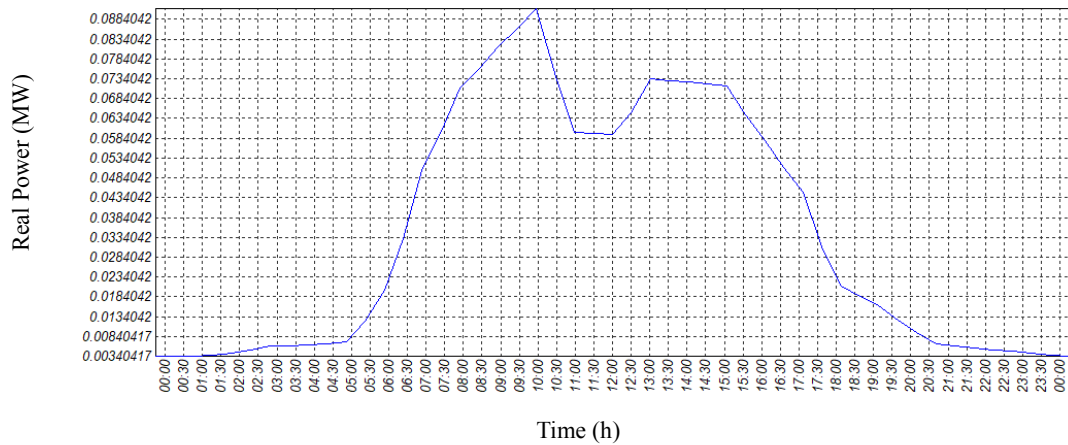

Figure 5.9. The results of the Real power loss (MW) of the distribution network transformer with EV.

In this point, real power measurements are essential for assessing grid stability and reliability. The integration of EVs introduces additional loads that can affect the power generation balance, and having a clear understanding of these effects is critical for maintaining reliable and uninterrupted power supply across the network. Accurate real power data allows engineers and grid operators to analyze the impacts of EV charging on the overall system and to take necessary actions to ensure stability. Moreover, accurate data on real power requirements facilitates better infrastructure planning. It provides the basis for decisions regarding the upgrading of transformers, enhancement of transmission lines, and increases in generation capacity to accommodate the expected rise in electricity demand due to widespread EV adoption. This planning is essential to support the growth in EV usage without compromising the performance of the power grid.

5.3.3. The Results of Loading Profile of Distribution's Network and Transformer

Understanding the loading profiles of a distribution network and its transformers, both with and without the integration of electric vehicles (EVs), is paramount for several strategic and operational reasons. With the rise of EVs, the additional demand they introduce can significantly alter load profiles. Evaluating these profiles

with and without EVs allows utilities to accurately forecast the need for infrastructure upgrades, including transformer upgrades or the installation of additional units.

This foresight helps in managing increased loads effectively, ensuring the infrastructure is neither underutilized nor overwhelmed. Figure 5.10, presents the results of loading profile of distribution's network without EV. Figure 5.11, demonstrated the results of the load profile of the entire distribution network transformer with EV.

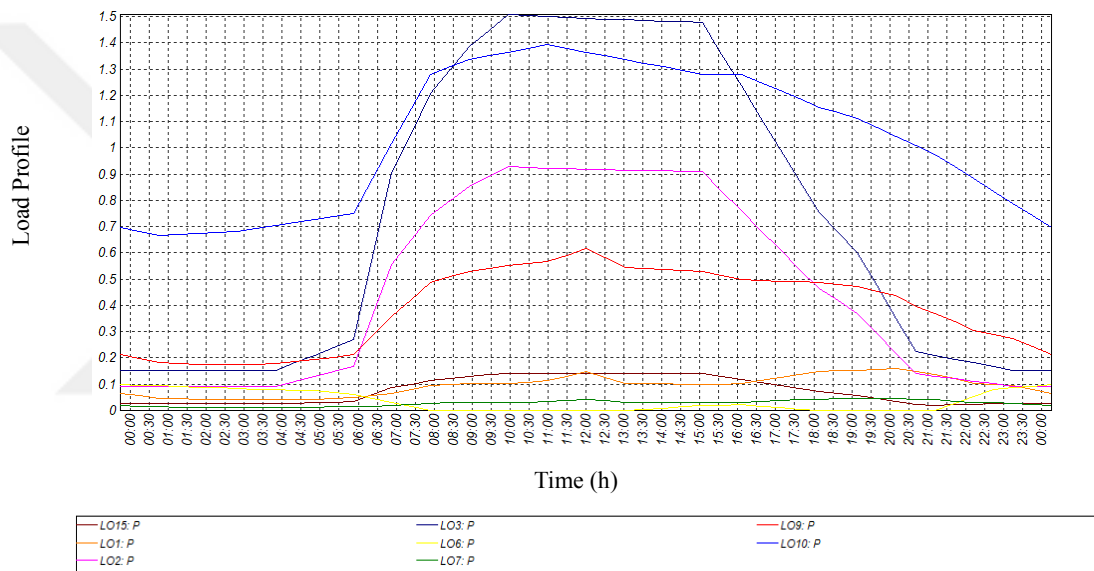

Figure 5.10. The results of loading profile of distribution's network without EV.

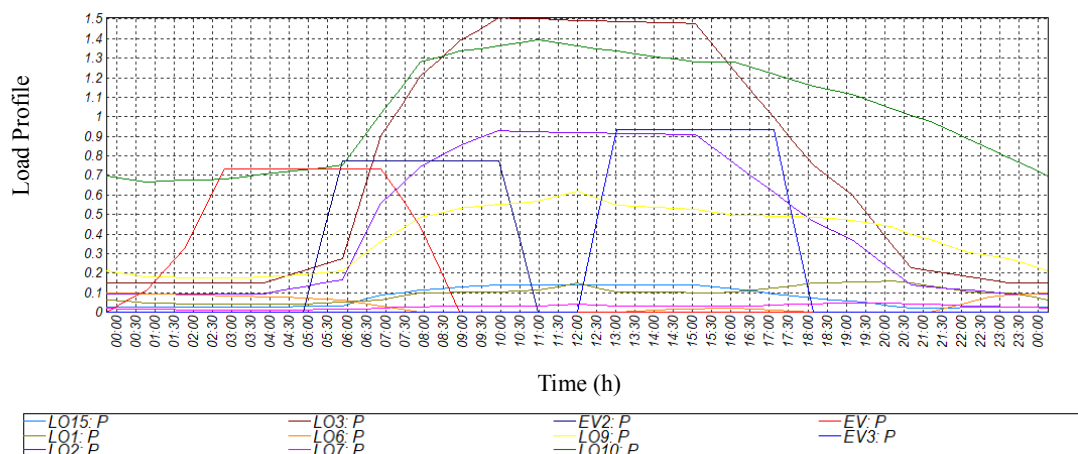

Figure 5.11. The results of the load profile of the entire distribution network transformer with EV.

Moreover, transformers are critical components that can be heavily impacted by the high and often fluctuating charging demands of EVs. Analyzing how load profiles change with the introduction of EVs can highlight potential risks of overloading and wear, guiding the necessary enhancements in transformer capacity and technology to handle these new loads without compromising the lifespan of the equipment. In doing so, load profiles with EVs can exhibit sharper peaks and troughs, particularly during popular charging times. By understanding these patterns, utilities can implement strategies such as demand response programs or time-of-use pricing to smooth peaks and fill valleys, thereby enhancing grid stability and reliability. Figure 5.12 shows the results of loading of distribution's network transformer without EV. Figure 5.13 indicates the results of loading of distribution's network transformer with EV.

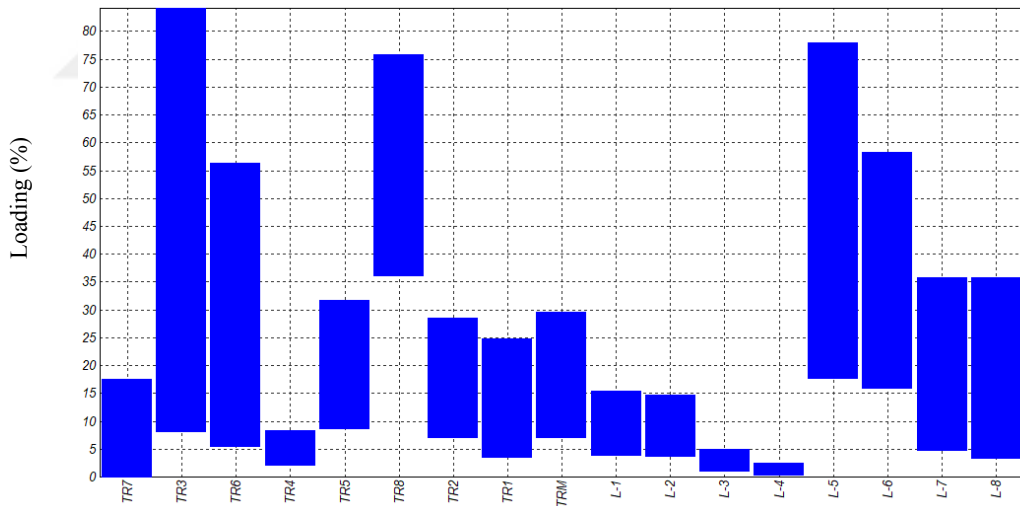

Figure 5.12. The results of loading of distribution's network transformer without EV.

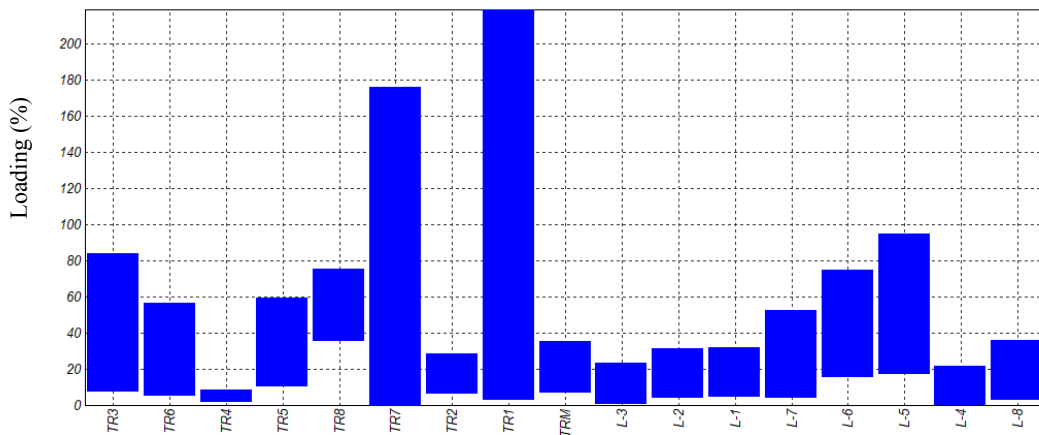

Figure 5.13. The results of loading of distribution's network transformer with EV.

For consumers, particularly those with EVs, understanding the impact of their charging habits on the distribution network can lead to more informed decisions about when and how they consume electricity. Utilities providing this information can enhance customer relations and potentially offer economic benefits through programs encouraging off-peak charging. In summary, analyzing the loading profiles of distribution networks and transformers with the inclusion of EVs is crucial for ensuring that the power systems are prepared to handle new demands.

PART 6

CONCLUSION AND FUTURE WORK

6.1. CONCLUSION

The thesis set out to explore the impact of electric vehicle (EV) charging on residential electricity distribution grids, a critical area of research given the increasing adoption of EVs and their potential implications for power systems. The

primary conclusion drawn from this study is that EV charging significantly influences residential distribution grids in several key aspects.

Firstly, the development and implementation of a model designed to simulate the distribution grid with anticipated EV charging loads revealed that time of charging plays a crucial role in grid management. This modeling demonstrated that peak charging times could significantly strain the grid unless properly managed with smart grid technologies or time-of-use incentives.

Secondly, the analysis of the relationship between EV adoption rates and charging patterns provided clear evidence that as more residents adopt EVs, without strategic management, the risk of voltage instability within residential grids increases. This underscores the need for utilities to adjust their infrastructure and management strategies to accommodate an evolving landscape where EVs are more prevalent.

Lastly, the evaluation of power losses due to increased demand from EV charging highlighted that without adequate upgrades and optimization, distribution grids might suffer from efficiency losses. These losses not only affect the economic operations of utilities but also the sustainability goals associated with reducing overall energy consumption and carbon emissions.

In conclusion, this thesis contributes valuable insights into the challenges and necessary strategies for integrating EV charging into residential distribution networks. It underscores the need for proactive grid management and infrastructure development to handle the upcoming surge in EV usage effectively. The findings advocate for a strategic approach to grid management that includes enhancing grid capacity, utilizing smart charging technologies, and possibly restructuring tariff systems to encourage off-peak charging. This will ensure that the shift towards electric vehicles aligns with the goals of maintaining grid stability, ensuring economic efficiency, and promoting environmental sustainability.

6.2. FUTURE WORK

Building on the findings from this thesis, several avenues for future research can be explored to deepen understanding and enhance the integration of electric vehicles (EVs) into residential distribution grids:

- **Advanced Grid Modeling Techniques:** Future studies could develop more sophisticated models that incorporate real-time data and machine learning algorithms to predict and manage the dynamics of EV charging more effectively. Such models could enhance the accuracy of simulations and allow for more dynamic management of grid resources.
- **Impact of Renewable Energy Integration:** As renewable energy adoption grows alongside EVs, it is crucial to examine how the concurrent use of renewables and electric vehicle charging can be optimized. Research could focus on integrating solar and wind energy sources directly into residential areas to mitigate the additional load from EVs.
- **Smart Charging Strategies:** Further investigation into smart charging technologies and their implementation could prove beneficial. Research could focus on the effectiveness of smart charging in balancing grid loads and optimizing energy usage, including the development of consumer-friendly smart charging apps and devices.
- **Policy and Economic Incentives:** Additional studies could analyze the impact of various policy and economic incentives on EV adoption and charging behavior. This includes exploring different tariff structures and incentives that encourage off-peak charging and assessing their real-world applicability and effectiveness.
- **Longitudinal Studies on EV Adoption Trends:** Conducting longitudinal studies to track EV adoption and charging habits over time would provide valuable insights into how behaviors change as infrastructure and technology evolve. This would aid utilities and policymakers in planning and implementing strategies that are responsive to consumer behavior.
- **Technological Advancements in Battery Storage:** Research into improved battery technology could explore how enhanced battery storage systems might be integrated into the residential grid infrastructure to support load

balancing and energy management, potentially reducing the strain from peak charging times.

By pursuing these areas of future work, researchers and industry stakeholders can continue to refine strategies for the successful integration of EVs into the electrical grid, ensuring that the transition to electric mobility is both sustainable and beneficial to all stakeholders involved.



REFERENCES

- [1] M. N. Tasnim, S. Akter, M. Shahjalal, T. Shams, P. Davari, and A. Iqbal, "A critical review of the effect of light duty electric vehicle charging on the power grid," *Energy Rep.*, vol. 10, pp. 4126–4147, 2023.
- [2] J. A. Sanguesa, V. Torres-Sanz, P. Garrido, F. J. Martinez, and J. M. Marquez-Barja, "A review on electric Vehicles: Technologies and challenges," *Smart Cities*, vol. 4, no. 1, pp. 372–404, 2021.
- [3] M. Khaleel, Z. Yusupov, B. Alfalh, M. T. Guneser, Y. Nassar, and H. El-Khozondar, "Impact of smart grid technologies on sustainable urban development," *INT. J. ELECTR. ENG. AND SUSTAIN.*, vol. 2, no. 2, pp. 62–82, 2024.
- [4] V. S. Naresh, G. V. N. S. R. Ratnakara Rao, and D. V. N. Prabhakar, "Predictive machine learning in optimizing the performance of electric vehicle batteries: Techniques, challenges, and solutions," *Wiley Interdiscip. Rev. Data Min. Knowl. Discov.*, 2024.
- [5] P. K. Das, M. Y. Bhat, and S. Sajith, "Life cycle assessment of electric vehicles: a systematic review of literature," *Environ. Sci. Pollut. Res. Int.*, vol. 31, no. 1, pp. 73–89, 2023.
- [6] S. C. A. Ahmed *et al.*, "Integrating Renewable Energy Sources with Electric Vehicle Infrastructure for Enhanced Renewability," in *3ed EAI International Conference on Intelligent Systems and Machine Learning (ICISML-2023)*, 5th-6th January 2024, Pune - India, 2024.
- [7] A. K. Karmaker, K. Prakash, M. N. I. Siddique, M. A. Hossain, and H. Pota, "Electric vehicle hosting capacity analysis: Challenges and solutions," *Renew. Sustain. Energy Rev.*, vol. 189, no. 113916, p. 113916, 2024.
- [8] K. M. Muttaqi, E. Isac, A. Mandal, D. Sutanto, and S. Akter, "Fast and random charging of electric vehicles and its impacts: State-of-the-art technologies and case studies," *Electric Power Syst. Res.*, vol. 226, no. 109899, p. 109899, 2024.
- [9] Imbayah, I., Eseid, O. A., Akter, K., Alsharif, A., & Ali Ahmed, A. (2023). Recent Developments in EV Charging Infrastructure: Opportunities and IoE Framework Challenges. *Int. J. Electr. Eng. And Sustain.*, 1(4), 47–63.
- [10] E. Elghanam, A. Alzaatreh, M. S. Hassan, and A. H. Osman, "A data-driven approach for EV electricity demand modeling using spatial regression: A

- UAE case study,” *IEEE Access*, vol. 12, pp. 57302–57314, 2024.
- [11] M. Khaleel, Z. Yusupov, A. Ahmed, A. Alsharif, Y. Nassar, and H. El-Khozondar, “Towards sustainable renewable energy,” *Appl. Sol. Energy*, vol. 59, no. 4, pp. 557–567, 2023.
- [12] Y. Vidyattama, R. Tanton, D. Sinclair, and J. Schirmer, “Simulating electric vehicle policy in the Australian capital territory,” *Transp. Policy (Oxf.)*, vol. 149, pp. 91–99, 2024.
- [13] M. F. Mekky and A. R. Collins, “The Impact of state policies on electric vehicle adoption -A panel data analysis,” *Renew. Sustain. Energy Rev.*, vol. 191, no. 114014, p. 114014, 2024.
- [14] R. Peng, J. H. C. G. Tang, X. Yang, M. Meng, J. Zhang, and C. Zhuge, “Investigating the factors influencing the electric vehicle market share: A comparative study of the European Union and United States,” *Appl. Energy*, vol. 355, no. 122327, p. 122327, 2024.
- [15] W.-L. Shang, J. Zhang, K. Wang, H. Yang, and W. Ochieng, “Can financial subsidy increase electric vehicle (EV) penetration---evidence from a quasi-natural experiment,” *Renew. Sustain. Energy Rev.*, vol. 190, no. 114021, p. 114021, 2024.
- [16] F. S. Hwang *et al.*, “Review of battery thermal management systems in electric vehicles,” *Renew. Sustain. Energy Rev.*, vol. 192, no. 114171, p. 114171, 2024.
- [17] A. Pamidimukkala, S. Kermanshachi, J. M. Rosenberger, and G. Hladik, “Barriers and motivators to the adoption of electric vehicles: A global review,” *Green Energy and Intelligent Transportation*, vol. 3, no. 2, p. 100153, 2024.
- [18] C. Yang, T. Sun, W. Wang, Y. Li, Y. Zhang, and M. Zha, “Regenerative braking system development and perspectives for electric vehicles: An overview,” *Renew. Sustain. Energy Rev.*, vol. 198, no. 114389, p. 114389, 2024.
- [19] A. Mohammed, O. Saif, M. Abo-Adma, A. Fahmy, and R. Elazab, “Strategies and sustainability in fast charging station deployment for electric vehicles,” *Sci. Rep.*, vol. 14, no. 1, pp. 1–19, 2024.
- [20] J. Pasha *et al.*, “Electric vehicle scheduling: State of the art, critical challenges, and future research opportunities,” *J. Ind. Inf. Integr.*, vol. 38, no. 100561, p. 100561, 2024.
- [21] M. Gobbi, A. Sattar, R. Palazzetti, and G. Mastinu, “Traction motors for electric vehicles: Maximization of mechanical efficiency – A review,” *Appl.*

Energy, vol. 357, no. 122496, p. 122496, 2024.

- [22] M. İnci, Ö. Çelik, A. Lashab, K. Ç. Bayındır, J. C. Vasquez, and J. M. Guerrero, “Power system integration of electric vehicles: A review on impacts and contributions to the smart grid,” *Appl. Sci. (Basel)*, vol. 14, no. 6, p. 2246, 2024.
- [23] B. Jin and Z. Liu, “Evaluating the impact of virtual energy storage under air conditioning and building coupling on the performance of a grid-connected distributed energy system,” *J. Build. Eng.*, vol. 89, no. 109309, p. 109309, 2024.
- [24] T. Adefarati, G. D. Obikoya, G. Sharma, A. K. Onaolapo, and K. T. Akindeji, “Design and feasibility analysis of grid-connected hybrid renewable energy system: perspective of commercial buildings,” *Energy Syst.*, vol. 15, no. 1, pp. 403–462, 2024.
- [25] M. Amir, Zaheeruddin, A. Haque, F. I. Bakhsh, V. S. B. Kurukuru, and M. Sedighizadeh, “Intelligent energy management scheme- based coordinated control for reducing peak load in grid- connected photovoltaic- powered electric vehicle charging stations,” *IET Gener. Transm. Distrib.*, vol. 18, no. 6, pp. 1205–1222, 2024.
- [26] G. Kannayeram, R. Muniraj, and R. Saravanan, “Impacts of electric vehicle charging station with the integration of renewable energy with grid connected system: a hybrid technique,” *Clean Technol. Environ. Policy*, vol. 25, no. 7, pp. 2433–2450, 2023.
- [27] N. Narasimhulu, M. Awasthy, R. Pérez de Prado, P. B. Divakarachari, and N. Himabindu, “Analysis and impacts of grid integrated photo-voltaic and electric Vehicle on power quality issues,” *Energies*, vol. 16, no. 2, p. 714, 2023.
- [28] Tung Tran The, D. Vo Ngoc, and N. Tran Anh, “Distribution network reconfiguration for power loss reduction and voltage profile improvement using chaotic stochastic fractal search algorithm,” *Complexity*, vol. 2020, pp. 1–15, 2020.
- [29] Y. Hou, J. Zhu, M. Z. Liu, W. J. Nacmanson, and L. F. Ochoa, “EV hosting capacity and voltage unbalance: An Australian case study,” in *2023 IEEE PES Grid Edge Technologies Conference & Exposition (Grid Edge)*, 2023, pp. 1–5.
- [30] S. Mondal and M. De, “Distributed energy resource deployment to mitigate adverse effects of high EV penetration in unbalanced distribution system by analytical sensitivity-based optimization,” *Electr. Power Compon. Syst.*, pp. 1–12, 2024.

- [31] V. Vijayan, A. Mohapatra, S. N. Singh, and C. L. Dewangan, "An efficient modular optimization scheme for unbalanced active distribution networks with uncertain EV and PV penetrations," *IEEE Trans. Smart Grid*, vol. 14, no. 5, pp. 3876–3888, 2023.
- [32] A. Jannesar Niri, G. A. Poelzer, S. E. Zhang, J. Rosenkranz, M. Pettersson, and Y. Ghorbani, "Sustainability challenges throughout the electric vehicle battery value chain," *Renew. Sustain. Energy Rev.*, vol. 191, no. 114176, p. 114176, 2024.
- [33] A. Mazza *et al.*, "Interaction among multiple electric vehicle chargers: Measurements on harmonics and power quality issues," *Energies*, vol. 16, no. 20, p. 7051, 2023.
- [34] L. Wang, X. Wang, N. Li, and T. Li, "Modelling and analysis of electromagnetic force, vibration, and noise in permanent magnet synchronous motor for electric vehicles under different working conditions considering current harmonics," *IET Electr. Power Appl.*, vol. 17, no. 7, pp. 952–964, 2023.
- [35] N. Gurav, Pradeepa, M. S. Adhokshaja, P. Anoor, and S. K. Bilgundi, "Mitigation of electric vehicles impact on grid current harmonics using DERs," *Aust. J. Electr. Electron. Eng.*, pp. 1–15, 2024.
- [36] A. Srivastava and S. Saravanan, "Harmonic mitigation using optimal active power filter for the improvement of power quality for a electric vehicle charging station," *e-Prime - Advances in Electrical Engineering, Electronics and Energy*, vol. 8, no. 100527, p. 100527, 2024.
- [37] W. Pinthurat, B. Hredzak, G. Konstantinou, and J. Fletcher, "Techniques for compensation of unbalanced conditions in LV distribution networks with integrated renewable generation: An overview," *Electric Power Syst. Res.*, vol. 214, no. 108932, p. 108932, 2023.
- [38] S. Sivakumar, S. B. Ramasamy Gunaseelan, M. V. Reddy Krishnakumar, N. Krishnan, A. Sharma, and A. Aguila Téllez, "Analysis of distribution systems in the presence of electric vehicles and optimal allocation of distributed generations considering power loss and voltage stability index," *IET Gener. Transm. Distrib.*, vol. 18, no. 6, pp. 1114–1132, 2024.
- [39] H. M. Hasanien *et al.*, "Hybrid particle swarm and sea horse optimization algorithm-based optimal reactive power dispatch of power systems comprising electric vehicles," *Energy (Oxf.)*, vol. 286, no. 129583, p. 129583, 2024.
- [40] P. Roy and A. Banerjee, "A study on performance parameters of three-level T-type inverter based PMSM drives for electric vehicles applications," *Electr. Eng. (Berl., Print)*, vol. 106, no. 2, pp. 1121–1134, 2024.

- [41] Y. Guo *et al.*, “Designing high-power-density electric motors for electric vehicles with advanced magnetic materials,” *World Electric Veh. J.*, vol. 14, no. 4, p. 114, 2023.
- [42] S. Sirisumrannukul, “Charging management of electric vehicles on loading capability of distribution system equipment, voltage quality, and energy loss by Monte Carlo simulation and linear programming,” *Int. Trans. Electr. Energy Syst.*, vol. 2023, pp. 1–37, 2023.
- [43] F. Li, I. Kocar, and A. Lesage-Landry, “Mitigating equipment overloads due to electric vehicle charging using customer incentives,” in *2023 IEEE Power & Energy Society General Meeting (PESGM)*, 2023, pp. 1–5.
- [44] V. L. Nezevak, “Limitation of power equipment traction substations overload due to the use of electricity storage systems,” *Transp. Res. Procedia*, vol. 68, pp. 318–324, 2023.
- [45] R. Reibsch, J. Gemassmer, and T. Katerbau, “Low voltage grid resilience: Evaluating electric vehicle charging strategies in the context of the grid development plan Germany,” *eTransportation*, vol. 20, no. 100323, p. 100323, 2024.
- [46] I. Chandra, N. K. Singh, and P. Samuel, “A comprehensive review on coordinated charging of electric vehicles in distribution networks,” *J. Energy Storage*, vol. 89, no. 111659, p. 111659, 2024.
- [47] I. Nutkani, H. Toole, N. Fernando, and L. P. C. Andrew, “Impact of EV charging on electrical distribution network and mitigating solutions – A review,” *IET Smart Grid*, 2024.
- [48] C. Jiang, L. Zhou, J. H. Zheng, and Z. Shao, “Electric vehicle charging navigation strategy in coupled smart grid and transportation network: A hierarchical reinforcement learning approach,” *Int. J. Electr. Power Energy Syst.*, vol. 157, no. 109823, p. 109823, 2024.
- [49] A. K. Singh and A. Kumar, “Impact of fast charging station for electric vehicles with grid integration: Forensic- based investigation and Archimedes optimization algorithm approach,” *Optim. Control Appl. Methods*, 2024.
- [50] S. P. R. S. Polisetty, R. Jayanthi, and M. Sai Veerraju, “An intelligent optimal charging stations placement on the grid system for the electric vehicle application,” *Energy (Oxf.)*, vol. 285, no. 129500, p. 129500, 2023.
- [51] S. Lai, J. Qiu, Y. Tao, and J. Zhao, “Pricing for electric vehicle charging stations based on the responsiveness of demand,” *IEEE Trans. Smart Grid*, vol. 14, no. 1, pp. 530–544, 2023.
- [52] H. Wang, X. Leng, Z. Liang, X. Huo, R. Yu, and J. Bian, “Electric vehicle dispatching strategy considering time cost and risk of operating distribution

- network,” *IET Energy Syst Integration*, vol. 5, no. 4, pp. 444–461, 2023.
- [53] E. Hartvigsson, M. Taljegard, M. Odenberger, and P. Chen, “A large-scale high-resolution geographic analysis of impacts of electric vehicle charging on low-voltage grids,” *Energy (Oxf.)*, vol. 261, no. 125180, p. 125180, 2022.
- [54] Balasundar, Sundarabalan, J. Sharma, Srinath, and J. M. Guerrero, “Effect of fault ride through capability on electric vehicle charging station under critical voltage conditions,” *IEEE Trans. Transp. Electrification*, vol. 8, no. 2, pp. 2469–2478, 2022.
- [55] L. He, J. He, L. Zhu, W. Huang, Y. Wang, and H. Yu, “Comprehensive evaluation of electric vehicle charging network under the coupling of traffic network and power grid,” *PLoS One*, vol. 17, no. 9, p. e0275231, 2022.
- [56] C. Crozier, T. Morstyn, and M. McCulloch, “The opportunity for smart charging to mitigate the impact of electric vehicles on transmission and distribution systems,” *Appl. Energy*, vol. 268, no. 114973, p. 114973, 2020.
- [57] E. Mancini, M. Longo, W. Yaici, and D. Zaninelli, “Assessment of the impact of electric vehicles on the design and effectiveness of electric distribution grid with distributed generation,” *Appl. Sci. (Basel)*, vol. 10, no. 15, p. 5125, 2020.
- [58] A. Jenn and J. Highleyman, “Distribution grid impacts of electric vehicles: A California case study,” *iScience*, vol. 25, no. 1, p. 103686, 2022.
- [59] S. Powell, G. V. Cezar, L. Min, I. M. L. Azevedo, and R. Rajagopal, “Charging infrastructure access and operation to reduce the grid impacts of deep electric vehicle adoption,” *Nat. Energy*, vol. 7, no. 10, pp. 932–945, 2022.
- [60] M. Xia, T. Liao, and Q. Chen, “Two-layer optimal charging strategy for electric vehicles in old residential areas,” *Int. Trans. Electr. Energy Syst.*, vol. 31, no. 6, 2021.
- [61] F. Gonzalez Venegas, M. Petit, and Y. Perez, “Active integration of electric vehicles into distribution grids: Barriers and frameworks for flexibility services,” *Renew. Sustain. Energy Rev.*, vol. 145, no. 111060, p. 111060, 2021.
- [62] S. S. Ravi and M. Aziz, “Utilization of electric vehicles for vehicle-to-grid services: Progress and perspectives,” *Energies*, vol. 15, no. 2, p. 589, 2022.
- [63] A. M. A. Haidar, K. M. Muttaqi, and D. Sutanto, “Technical challenges for electric power industries due to grid-integrated electric vehicles in low voltage distributions: A review,” *Energy Convers. Manag.*, vol. 86, pp. 689–700, 2014.

- [64] N. V. Martyushev, B. V. Malozyomov, S. N. Sorokova, E. A. Efremenkov, and M. Qi, "Mathematical modeling of the state of the battery of cargo electric vehicles," *Mathematics*, vol. 11, no. 3, p. 536, 2023.
- [65] H. S. Das, M. M. Rahman, S. Li, and C. W. Tan, "Electric vehicles standards, charging infrastructure, and impact on grid integration: A technological review," *Renew. Sustain. Energy Rev.*, vol. 120, no. 109618, p. 109618, 2020.
- [66] S. Babbar, "Exploring the prosperity and market dynamics of IoT-infused electric vehicle services: A review," *J. Res. Adm.*, vol. 5, no. 2, pp. 11690–11699, 2023.
- [67] M. C.-P. Poo, Y.-Y. Lau, B. Qi, and C. F.-K. Pun, "Sustainable ground transportation and the E-commerce revolution: Innovations and challenges at the intersection," *Encyclopedia (Basel, 2021)*, vol. 4, no. 1, pp. 201–214, 2024.
- [68] M. S. Koroma *et al.*, "Life cycle assessment of battery electric vehicles: Implications of future electricity mix and different battery end-of-life management," *Sci. Total Environ.*, vol. 831, no. 154859, p. 154859, 2022.
- [69] A. Singh, K. Pal, and C. B. Vishwakarma, "State of charge estimation techniques of Li-ion battery of electric vehicles," *e-Prime - Advances in Electrical Engineering, Electronics and Energy*, vol. 6, no. 100328, p. 100328, 2023.
- [70] K. Khan, I. Samuilik, and A. Ali, "A mathematical model for dynamic electric vehicles: Analysis and optimization," *Mathematics*, vol. 12, no. 2, p. 224, 2024.
- [71] Q. T. Tran, L. Roose, C. Vichitpunt, K. Thongmai, and K. Noisopa, "A comprehensive model to estimate electric vehicle battery's state of charge for a pre-scheduled trip based on energy consumption estimation," *Clean Technol.*, vol. 5, no. 1, pp. 25–37, 2022.
- [72] M. Li, F. K.-D. Noering, Y. Öngün, M. Appelt, and R. Henze, "Investigation of low-frequency data significance in electric vehicle drivetrain durability development," *World Electric Veh. J.*, vol. 15, no. 3, p. 88, 2024.
- [73] A. Mahmud, A. H. Sarower, A. Sohel, M. Assaduzzaman, and T. Bhuiyan, "Adoption of ChatGPT by university students for academic purposes: Partial least square, artificial neural network, deep neural network and classification algorithms approach," *Array (N. Y.)*, vol. 21, no. 100339, p. 100339, 2024.
- [74] C. Diaz-Londono, G. Fambri, P. Maffezzoni, and G. Gruosso, "Enhanced EV charging algorithm considering data-driven workplace chargers categorization with multiple vehicle types," *eTransportation*, vol. 20, no. 100326, p. 100326, 2024.

- [75] M. Khaleel *et al.*, “An optimization approaches and control strategies of Hydrogen Fuel Cell Systems in EDG-integration based on DVR technology,” *Journal Européen des Systèmes Automatisés*, vol. 57, no. 2, pp. 551–565, 2024.
- [76] H. Zhang and J. Qiu, “A novel navigation and charging strategy for electric vehicles based on customer classification in power-traffic network,” *Int. J. Electr. Power Energy Syst.*, vol. 158, no. 109931, p. 109931, 2024.
- [77] Y. Gulzar, M. Dutta, D. Gupta, S. Juneja, A. B. Soomro, and M. S. Mir, “Revolutionizing mobility: a comprehensive review of electric vehicles charging stations in India,” *Front. Sustain. Cities*, vol. 6, 2024.
- [78] G. Mittal, A. Garg, and K. Pareek, “A review of the technologies, challenges and policies implications of electric vehicles and their future development in India,” *Energy Storage*, vol. 6, no. 1, 2024.
- [79] M. Khaleel *et al.*, “Towards hydrogen sector investments for achieving sustainable electricity generation,” *Solar Energy and Sustainable Development*, vol. 13, no. 1, pp. 71–96, 2024.
- [80] J. Benajes, A. García, J. Monsalve-Serrano, and M. Guzmán-Mendoza, “A review on low carbon fuels for road vehicles: The good, the bad and the energy potential for the transport sector,” *Fuel (Lond.)*, vol. 361, no. 130647, p. 130647, 2024.
- [81] L. Kistner, A. Bensmann, and R. Hanke-Rauschenbach, “Potentials and limitations of battery-electric container ship propulsion systems,” *Energy Conversion and Management: X*, vol. 21, no. 100507, p. 100507, 2024.
- [82] E. Louback, A. Biswas, F. Machado, and A. Emadi, “A review of the design process of energy management systems for dual-motor battery electric vehicles,” *Renew. Sustain. Energy Rev.*, vol. 193, no. 114293, p. 114293, 2024.
- [83] M. Khaleel and M. Elbar, “Exploring the rapid growth of solar photovoltaics in the European Union,” *INT. J. ELECTR. ENG. AND SUSTAIN.*, vol. 2, no. 1, pp. 61–68, 2024.
- [84] Y. Nassar and M. Khaleel, “Sustainable development and the surge in electricity demand across emerging economies,” *Int. J. Electr. Eng. and Sustain.*, pp. 51–60, 2024.
- [85] T. Cotterman, E. R. H. Fuchs, K. S. Whitefoot, and C. Combemale, “The transition to electrified vehicles: Evaluating the labor demand of manufacturing conventional versus battery electric vehicle powertrains,” *Energy Policy*, vol. 188, no. 114064, p. 114064, 2024.

- [86] A. Ghayth, Z. Yusupov, and M. Khaleel, "Performance enhancement of PV array utilizing Perturb & Observe algorithm," *Int. J. Electr. Eng. and Sustain.*, pp. 29–37, 2023.
- [87] D. Horak, A. Hainoun, G. Neugebauer, and G. Stoeglehner, "Battery electric vehicle energy demand in urban energy system modeling: A stochastic analysis of added flexibility for home charging and battery swapping stations," *Sustain. Energy Grids Netw.*, vol. 37, no. 101260, p. 101260, 2024.
- [88] A. Alsharif, A. A. Ahmed, M. M. Khaleel, Y. Nassar, M. A. Sharif, and H. J. El-Khozondar, "Whale optimization algorithm for renewable energy sources integration considering solar-to-vehicle technology," in *2023 IEEE 9th International Women in Engineering (WIE) Conference on Electrical and Computer Engineering (WIECON-ECE)*, 2023.
- [89] A. Alsharif, A. A. Ahmed, M. M. Khaleel, A. S. Daw Alarga, O. S. M. Jomah, and I. Imbayah, "Comprehensive state-of-the-art of vehicle-to-grid technology," in *2023 IEEE 3rd International Maghreb Meeting of the Conference on Sciences and Techniques of Automatic Control and Computer Engineering (MI-STA)*, 2023, pp. 530–534.
- [90] M. Khaleel *et al.*, "Electric vehicles in China, Europe, and the United States: Current trend and market comparison," *Int. J. Electr. Eng. and Sustain.*, pp. 1–20, 2024.
- [91] A. Alsharif *et al.*, "Impact of electric Vehicle on residential power distribution considering energy management strategy and stochastic Monte Carlo algorithm," *Energies*, vol. 16, no. 3, p. 1358, 2023.
- [92] H. Sahin, "Hydrogen refueling of a fuel cell electric vehicle," *Int. J. Hydrogen Energy*, 2024.
- [93] J. Sim *et al.*, "Variation in performance and characteristics of long-term operated gas diffusion layer in a fuel cell electric vehicle," *J. Power Sources*, vol. 595, no. 234026, p. 234026, 2024.
- [94] M. M. Khaleel, S. A. Abulifa, and A. A. Abulifa, "Artificial intelligent techniques for identifying the cause of disturbances in the power grid," *Brilliance: Research of Artificial Intelligence*, vol. 3, no. 1, pp. 19–31, 2023.
- [95] R. Nanmaran *et al.*, "Mathematical modelling of hydrogen transportation from reservoir tank to hydrogen fuel cell electric vehicle (FCEV) tank," *Fuel (Lond.)*, vol. 361, no. 130725, p. 130725, 2024.
- [96] F. Alasali, A. S. Saidi, N. El-Naily, O. Alsmadi, M. Khaleel, and I. Ghirani, "Assessment of the impact of a 10-MW grid-tied solar system on the Libyan grid in terms of the power-protection system stability," *Clean Energy*, vol. 7,

no. 2, pp. 389–407, 2023.

- [97] X. A. Martin, M. Escoto, A. Guerrero, and A. A. Juan, “Battery management in electric vehicle routing problems: A review,” *Energies*, vol. 17, no. 5, p. 1141, 2024.
- [98] S. E. Faghieh, I. Chitsaz, and A. Ghasemi, “A component sizing prediction study for a series hybrid electric vehicle based on artificial neural network,” *Int. J. Engine Res.*, vol. 25, no. 1, pp. 47–64, 2024.
- [99] M. Khaleel, Z. Yusupov, N. Yasser, and H. Elkhazondar, “Enhancing Microgrid performance through hybrid energy storage system integration: ANFIS and GA approaches,” *International Journal of Electrical Engineering and Sustainability (IJEES)*, vol. 1, no. 2, pp. 38–48, 2023
- [100] A. Ghayth, M. Şimşir, M. Khaleel, A. Ahmed, and A. Alsharif, “An investigation of Inverse-Automatic Mechanical Transmission of EV using gear downshift approach,” *Int. J. Electr. Eng. and Sustain.*, pp. 1–9, 2023.
- [101] P. Karjalainen *et al.*, “Real-world emissions of nanoparticles, particulate mass and black carbon from a plug-in hybrid vehicle compared to conventional gasoline vehicles,” *Environ. Adv.*, vol. 15, no. 100454, p. 100454, 2024.
- [102] P. Mousavi, M. S. Ghazizadeh, and V. Vahidinasab, “Optimal plug- in hybrid electric vehicle performance management using decentralized multichannel network design,” *IET Gener. Transm. Distrib.*, vol. 18, no. 5, pp. 999–1013, 2024.
- [103] C. Yang, X. Du, W. Wang, L. Yuan, and L. Yang, “Variable optimization domain-based cooperative energy management strategy for connected plug-in hybrid electric vehicles,” *Energy (Oxf.)*, vol. 290, no. 130206, p. 130206, 2024.
- [104] D. Chakraborty, S. Hardman, and G. Tal, “Why do some consumers not charge their plug-in hybrid vehicles? Evidence from Californian plug-in hybrid owners,” *Environ. Res. Lett.*, vol. 15, no. 8, p. 084031, 2020.
- [105] M. Khaleel, M. R. Adzman, and S. M. Zali, “An integrated of hydrogen fuel cell to distribution network system: Challenging and opportunity for D-STATCOM,” *Energies*, vol. 14, no. 21, p. 7073, 2021.
- [106] M. M. Khaleel, M. R. Adzman, S. M. Zali, M. M. Graisa, and A. A. Ahmed, “A review of fuel cell to distribution network interface using D-FACTS: Technical challenges and interconnection trends,” *Int. J. Electr. Electron. Eng. Telecommun.*, vol. 10, no. 5, pp. 319–332, 2021.
- [107] S. Rahman, I. A. Khan, A. A. Khan, A. Mallik, and M. F. Nadeem, “Comprehensive review & impact analysis of integrating projected electric vehicle charging load to the existing low voltage distribution system,” *Renew.*

Sustain. Energy Rev., vol. 153, no. 111756, p. 111756, 2022.

- [108] M. Khaleel, A. A. Ahmed, and A. Alsharif, "Energy Management System Strategies in Microgrids: A Review," *The North African Journal of Scientific Publishing (NAJSP)*, vol. 1, no. 1, pp. 1–8, 2023.
- [109] R. Fachrizal, U. H. Ramadhani, J. Munkhammar, and J. Widén, "Combined PV–EV hosting capacity assessment for a residential LV distribution grid with smart EV charging and PV curtailment," *Sustain. Energy Grids Netw.*, vol. 26, no. 100445, p. 100445, 2021.
- [110] M. Khaleel, Z. Yusupov, N. Yasser, H. Elkhazondar, and A. A. Ahmed, "An integrated PV farm to the unified power flow controller for electrical power system stability," *International Journal of Electrical Engineering and Sustainability (IJEES)*, vol. 1, no. 1, pp. 18–30, 2023.
- [111] B. Azzopardi and Y. Gabdullin, "Impacts of electric vehicles charging in low-voltage distribution networks: A case study in Malta," *Energies*, vol. 17, no. 2, p. 289, 2024.
- [112] N. B. G. Brinkel *et al.*, "Impact of rapid PV fluctuations on power quality in the low-voltage grid and mitigation strategies using electric vehicles," *Int. J. Electr. Power Energy Syst.*, vol. 118, no. 105741, p. 105741, 2020.
- [113] M. Khaleel, Z. Yusupov, Y. Nassar, H. J. El-khozondar, A. Ahmed, and A. Alsharif, "Technical challenges and optimization of superconducting magnetic energy storage in electrical power systems," *e-Prime - Advances in Electrical Engineering, Electronics and Energy*, vol. 5, no. 100223, p. 100223, 2023.
- [114] M. Khaleel, Z. Yusupov, M. Elmnifi, T. Elmenfy, Z. Rajab, and M. Elbar, "Assessing the financial impact and mitigation methods for voltage sag in power grid," *Int. J. Electr. Eng. and Sustain.*, pp. 10–26, 2023.
- [115] M. Khaleel, E. Yaghoubi, E. Yaghoubi, and M. Z. Jahromi, "The role of mechanical energy storage systems based on artificial intelligence techniques in future sustainable energy systems," *Int. J. Electr. Eng. and Sustain.*, pp. 01–31, 2023.
- [116] M. Khaleel, Z. Yusupov, N. Yasser, and H. J. El-Khozondar, "Enhancing Microgrid performance through hybrid energy storage system integration: ANFIS and GA approaches," *Int. J. Electr. Eng. and Sustain.*, pp. 38–48, 2023.
- [117] A. Ghayth, Z. Yusupov, and M. Khaleel, "Performance enhancement of PV array utilizing Perturb & Observe algorithm," *Int. J. Electr. Eng. and Sustain.*, pp. 29–37, 2023.

- [118] M. Khaleel, N. El-Naily, H. Alzargi, M. Amer, T. Ghandoori, and A. Abulifa, "Recent progress in synchronization approaches to mitigation voltage sag using HESS D-FACTS," in *2022 International Conference on Emerging Trends in Engineering and Medical Sciences (ICETEMS)*, 2022.
- [119] M. M. Khaleel, Z. Yusupov, M. T. Güneşer, A. A. Abulifa, A. A. Ahmed, and A. Alsharif, "The effect of PEMFC on power grid using advanced equilibrium optimizer and particle swarm optimisation for voltage sag mitigation," in *2023 IEEE 3rd International Maghreb Meeting of the Conference on Sciences and Techniques of Automatic Control and Computer Engineering (MI-STA)*, 2023.
- [120] L. Wang, Z. Qin, T. Slangen, P. Bauer, and T. van Wijk, "Grid impact of electric vehicle fast charging stations: Trends, standards, issues and mitigation measures - an overview," *IEEE Open J. Power Electron.*, vol. 2, pp. 56–74, 2021.
- [121] P. Vishnuram and S. Alagarsamy, "Grid integration for electric vehicles: A realistic strategy for environmentally friendly mobility and renewable power," *World Electric Veh. J.*, vol. 15, no. 2, p. 70, 2024.
- [122] M. M. Khaleel, S. A. Abulifa, I. M. Abdaldeam, A. A. Abulifa, M. Amer, and T. M. Ghandoori, "A current assessment of the renewable energy industry," *African Journal of Advanced Pure and Applied Sciences (AJAPAS)*, vol. 2, no. 1, pp. 122–127, 2023.
- [123] A. Tavakoli, S. Saha, M. T. Arif, M. E. Haque, N. Mendis, and A. M. T. Oo, "Impacts of grid integration of solar PV and electric vehicle on grid stability, power quality and energy economics: a review," *IET Energy Systems Integration*, vol. 2, no. 3, pp. 243–260, 2020.
- [124] M. M. Khaleel, A. A. Ahmed, and A. Alsharif, "Artificial Intelligence in Engineering," *Brilliance: Research of Artificial Intelligence*, vol. 3, no. 1, pp. 32–42, 2023.
- [125] X. Liu, X. Liu, X. Zhang, Y. Zhou, J. Chen, and X. Ma, "Optimal location planning of electric bus charging stations with integrated photovoltaic and energy storage system," *Comput.-aided Civ. Infrastruct. Eng.*, vol. 38, no. 11, pp. 1424–1446, 2023.
- [126] M. Khaleel, "Intelligent Control Techniques for Microgrid Systems," *Brilliance: Research of Artificial Intelligence*, vol. 3, no. 1, pp. 56–67, 2023.
- [127] M. Khaleel, Ziyodulla Yusupov, Abdussalam Ali Ahmed, Abdulagader Alsharif, Ahmed Alarga, and Ibrahim Imbayah, "The Effect of Digital Technologies on Energy Efficiency Policy", *Int. J. Electr. Eng. and Sustain.*, vol. 1, no. 1, pp. 1–8, Jan. 2023.

- [128] Y. F. Nassar *et al.*, “Carbon footprint and energy life cycle assessment of wind energy industry in Libya,” *Energy Convers. Manag.*, vol. 300, no. 117846, p. 117846, 2024.
- [129] L. Shi, G. Chen, and S. Wang, “Dynamic analysis of the investment decision of electric vehicle charging facilities and the promotion effect measurement for electric vehicles,” *Eur. J. Transp. Infrastruct. Res.*, vol. 23, no. 2, 2023.
- [130] A. Alsharif, A. A. Ahmed, M. M. Khaleel, A. S. D. Alarga, O. S. M. Jomah, and A. B. E. Alrashed, “Stochastic method and sensitivity analysis assessments for vehicle-to-home integration based on renewable energy sources,” in *2023 IEEE 3rd International Maghreb Meeting of the Conference on Sciences and Techniques of Automatic Control and Computer Engineering (MI-STA)*, 2023.
- [131] M. Andeef, Y. F. Nassar, H. Awad, H. J. El-Khozondar, and M. Khaleel, “Transitioning to solar fuel instead of fossil fuel in the electricity industry,” *Int. J. Electr. Eng. and Sustain.*, pp. 32–46, 2023.
- [132] A. A. Ahmed, M. Belrzaeg, Y. Nassar, H. J. El-Khozondar, M. Khaleel, and A. Alsharif, “A comprehensive review towards smart homes and cities considering sustainability developments, concepts, and future trends,” *World Journal of Advanced Research and Reviews*, pp. 1482–1489, 2023.
- [133] E. Mahmoudi, T. A. dos Santos Barros, and E. R. Filho, “Forecasting urban electric vehicle charging power demand based on travel trajectory simulation in the realistic urban street network,” *Energy Rep.*, vol. 11, pp. 4254–4276, 2024.
- [134] M. Mazumder and S. Debbarma, “EV charging stations with a provision of V2G and voltage support in a distribution network,” *IEEE Syst. J.*, vol. 15, no. 1, pp. 662–671, 2021.
- [135] M. Khaleel, M. Şimşir, Z. Yusupov, N. Yasser, H. Elkhazondar, and A. A. Ahmed, “The role of fault detection and diagnosis in induction motors,” *International Journal of Electrical Engineering and Sustainability (IJEES)*, vol. 1, no. 1, pp. 31–40, 2023.
- [136] H. Yu, J. Tu, X. Lei, Z. Shao, and L. Jian, “A cost-effective and high-efficient EV shared fast charging scheme with hierarchical coordinated operation strategy for addressing difficult-to-charge issue in old residential communities,” *Sustain. Cities Soc.*, vol. 101, no. 105090, p. 105090, 2024.
- [137] G. J. Carlton and S. Sultana, “Electric vehicle charging equity and accessibility: A comprehensive United States policy analysis,” *Transp. Res. D Transp. Environ.*, vol. 129, no. 104123, p. 104123, 2024.

- [138] A. Bensalem, B. Toual, M. Elbar, M. Khaleel, and Z. Belboul, “A framework to quantify battery degradation in residential microgrid operate with maximum self-consumption based energy management system”, *SEES*, vol. 5, no. 1, pp. 354–370, Feb. 2024.
- [139] W. Huang, J. Wang, J. Wang, H. Zeng, M. Zhou, and J. Cao, “EV charging load profile identification and seasonal difference analysis via charging sessions data of charging stations,” *Energy (Oxf.)*, vol. 288, no. 129771, p. 129771, 2024.
- [140] M. Shafiei and A. Ghasemi-Marzbali, “Fast-charging station for electric vehicles, challenges and issues: A comprehensive review,” *J. Energy Storage*, vol. 49, no. 104136, p. 104136, 2022.
- [141] S. Abulifa, M. Elbar, M. Mohamed, A. Khoudiri, and S. Khoudiri, “Performance Evaluation of MG Systems Interfaced with Wind Turbines Employing DFIG Technology”, *Int. J. Electr. Eng. and Sustain.*, vol. 2, no. 2, pp. 22–35, Apr. 2024.
- [142] D. Benavides, P. Arévalo, E. Villa-Ávila, J. A. Aguado, and F. Jurado, “Predictive power fluctuation mitigation in grid-connected PV systems with rapid response to EV charging stations,” *J. Energy Storage*, vol. 86, no. 111230, p. 111230, 2024.
- [143] A. Esmaili, M. M. Oshanreh, S. Naderian, D. MacKenzie, and C. Chen, “Assessing the spatial distributions of public electric vehicle charging stations with emphasis on equity considerations in King County, Washington,” *Sustain. Cities Soc.*, vol. 107, no. 105409, p. 105409, 2024.
- [144] S. Kudva, K. Kulkarni, C. Maheshwari, A. Aswani, and S. Sastry, “Understanding the impact of coalitions between EV charging stations,” *arXiv [math.OC]*, 2024.
- [145] W. Meng *et al.*, “Distributed energy management of electric vehicle charging stations based on hierarchical pricing mechanism and aggregate feasible regions,” *Energy (Oxf.)*, vol. 291, no. 130332, p. 130332, 2024.
- [146] A. K. M. Yousuf, Z. Wang, R. Paranjape, and Y. Tang, “An in-depth exploration of electric vehicle charging station infrastructure: A comprehensive review of challenges, mitigation approaches, and optimization strategies,” *IEEE Access*, vol. 12, pp. 51570–51589, 2024.
- [147] M. Elmnifi, M. Khaleel, S. Vambol, S. Yermenko, Y. F. Nassar, and O. Dzhulai, “Ensuring sustainability in Libya with renewable energy and pumped hydro storage,” *Ecol. Quest.*, vol. 35, no. 3, pp. 1–17, 2024.
- [148] D. M. Nguyen, M. A. Kishk, and M.-S. Alouini, “Dynamic charging as a

- complementary approach in modern EV charging infrastructure,” *Sci. Rep.*, vol. 14, no. 1, pp. 1–12, 2024.
- [149] M. Khaleel, A. A. Ahmed, and A. Alsharif, “Technology challenges and trends of electric motor and drive in electric vehicle,” *Int. J. Electr. Eng. and Sustain.*, pp. 41–48, 2023.
- [150] A. Alsharif, C. W. Tan, R. Ayop, A. Ali Ahmed, M. Mohamed Khaleel, and A. K. Abobaker, “Power management and sizing optimization for hybrid grid-dependent system considering photovoltaic wind battery electric vehicle,” in *2022 IEEE 2nd International Maghreb Meeting of the Conference on Sciences and Techniques of Automatic Control and Computer Engineering (MI-STA)*, 2022.
- [151] A. A. Ahmed, A. Alsharif, T. Triwiyanto, M. Khaleel, C. W. Tan, and R. Ayop, “Using of neural network-based controller to obtain the effect of hub motors weight on electric vehicle ride comfort,” in *2022 IEEE 2nd International Maghreb Meeting of the Conference on Sciences and Techniques of Automatic Control and Computer Engineering (MI-STA)*, 2022.
- [152] A. Kazemtarghi, A. Mallik, and Y. Chen, “Dynamic pricing strategy for electric vehicle charging stations to distribute the congestion and maximize the revenue,” *Int. J. Electr. Power Energy Syst.*, vol. 158, no. 109946, p. 109946, 2024.
- [153] M. Yao, D. Da, X. Lu, and Y. Wang, “A review of capacity allocation and control strategies for electric vehicle charging stations with integrated photovoltaic and energy storage systems,” *World Electric Veh. J.*, vol. 15, no. 3, p. 101, 2024.
- [154] S. Jagani, E. Marsillac, and P. Hong, “The electric vehicle supply chain ecosystem: Changing roles of automotive suppliers,” *Sustainability*, vol. 16, no. 4, p. 1570, 2024.
- [155] Z. Feng, F. Li, and C. Tan, “Supplier development or supplier integration? Equilibrium analysis in competing electric vehicle supply chains with power battery recycling,” *Expert Syst. Appl.*, vol. 238, no. 121519, p. 121519, 2024.
- [156] S. Khan, K. Sudhakar, M. Hazwan Yusof, and S. Sundaram, “Review of Building Integrated Photovoltaics system for Electric Vehicle charging,” *Chem. Rec.*, vol. 24, no. 3, 2024.
- [157] Z. Zhao, C. K. M. Lee, and J. Ren, “A two-level charging scheduling method for public electric vehicle charging stations considering heterogeneous demand and nonlinear charging profile,” *Appl. Energy*, vol. 355, no. 122278, p. 122278, 2024.
- [158] F. A. Bhat, G. Y. Tiwari, and A. Verma, “Preferences for public electric vehicle charging infrastructure locations: A discrete choice analysis,” *Transp.*

Policy (Oxf.), vol. 149, pp. 177–197, 2024.

- [159] G. Rajendran, C. A. Vaithilingam, N. Misron, K. Naidu, and M. R. Ahmed, “A comprehensive review on system architecture and international standards for electric vehicle charging stations,” *J. Energy Storage*, vol. 42, no. 103099, p. 103099, 2021.
- [160] V.-B. Vu, J. M. Gonzalez-Gonzalez, V. Pickert, M. Dahidah, and A. Trivino, “A hybrid charger of conductive and inductive modes for electric vehicles,” *IEEE Trans. Ind. Electron.*, vol. 68, no. 12, pp. 12021–12033, 2021.
- [161] M. K. Rahman, F. A. Tanvir, M. S. Islam, M. S. Ahsan, and M. Ahmed, “Design and implementation of low-cost electric vehicles (EVs) supercharger: A comprehensive review,” *arXiv [eess.SY]*, 2024.
- [162] A. Alsharif, C. W. Tan, R. Ayop, A. A. Ali Ahmed, A. Alanssari, and M. M. Khaleel, “Energy Management Strategy for Vehicle-to-Grid Technology Integration with Energy Sources: Mini review,” *AJAPAS*, vol. 1, no. 1, pp. 12–16, Jan. 2022.
- [163] Z. Gholami, R. Ildarabadi, H. Heydari-Doostabad, M. Monfared, and T. O’Donnell, “Bidirectional wide range and high voltage gain buck-boost DC-DC converter for EV chargers empowering V2G- G2V applications,” *IET Power Electron.*, vol. 17, no. 2, pp. 230–250, 2024.
- [164] M. Belrzaeg, A. A. Ahmed, M. M. Khaleel, A. Alsharif, M. M. Rahmah, and A. S. D. Alarga, “Suspension system control process for buses with in-wheel motors,” in *ICCEIS 2022*, 2023, vol. 29, p. 4.
- [165] M. Z. Farooqi, B. Singh, and B. K. Panigrahi, “Enhanced control and modulation of on-board integrated EV charger with active power decoupling capability,” *IEEE Trans. Transp. Electrifi.*, vol. PP, no. 99, pp. 1–1, 2024.
- [166] D. Bhule and R. S. Kaarthik, “A model predictive control scheme for a single-phase integrated battery charger with active power decoupling for EV application,” *IEEE Trans. Power Electron.*, vol. 39, no. 4, pp. 4117–4126, 2024.
- [167] M. Abdulhameed, E. ElGhanam, A. H. Osman, and M. S. Hassan, “Design of a misalignment-tolerant inductor–capacitor–capacitor-compensated wireless charger for roadway-powered electric vehicles,” *Sustainability*, vol. 16, no. 2, p. 567, 2024.
- [168] M. Patel, P. Arora, R. Singh, D. Mahapatra, V. Chaturvedi, and S. Kumar Saini, “Impact of battery swapping in the passenger sector: EV adoption, emissions, and energy mix,” *Energy (Oxf.)*, no. 131393, p. 131393, 2024.

- [169] G. Adu-Gyamfi, H. Song, E. Nketiah, B. Obuobi, Q. Wu, and D. Cudjoe, "Refueling convenience and range satisfaction in electric mobility: Investigating consumer willingness to use battery swap services for electric vehicles," *J. Retail. Consum. Serv.*, vol. 79, no. 103800, p. 103800, 2024.
- [170] H. Lv, F. Zhang, M. Wong, Q. Xing, and Y. Ji, "Activity-Based travel chain simulation for Battery-Swapping demand of electric micromobility vehicles," *Transp. Res. D Transp. Environ.*, vol. 126, no. 104022, p. 104022, 2024.
- [171] W. Zhou, M. Li, Q. Zhang, Z. Li, S. Xie, and Y. Fan, "Potential and challenges of capacitive power transfer systems for wireless EV charging: A re-view of key technologies," *Green Energy and Intelligent Transportation*, no. 100174, p. 100174, 2024.
- [172] M. Rabih, M. Takruri, M. Al-Hattab, A. A. Alnuaimi, and M. R. Bin Thaleth, "Wireless charging for electric vehicles: A survey and comprehensive guide," *World Electric Veh. J.*, vol. 15, no. 3, p. 118, 2024.
- [173] B. Manivannan, P. Kathirvelu, and R. Balasubramanian, "A review on wireless charging methods – The prospects for future charging of EV," *Renew. Energy Focus*, vol. 46, pp. 68–87, 2023.

RESUME

After completing an intermediate diploma specializing in precision instruments at the Petroleum Institute in Tripoli, Libya in 2010, Abdullah GHAYTH pursued further education in electrical engineering and power systems at Ajdabiya University, from which he graduated in 2017. Currently, he is furthering his master study in the Department of Electrical and Electronic Engineering at Karabuk University in Türkiye.

