

**T.C.
ISTANBUL AYDIN UNIVERSITY
INSTITUTE OF GRADUATE STUDIES**



**ENERGY MANAGEMENT & CONTROL SYSTEM FOR
MICROGRID BASED (WIND-PV-BATTERY)**

MASTER'S THESIS

Abrar AHMED

**Department of Electrical & Electronic Engineering
Electrical and Electronics Engineering Program**

August, 2021

T.C.
ISTANBUL AYDIN UNIVERSITY
INSTITUTE OF GRADUATE STUDIES



ENERGY MANAGEMENT & CONTROL SYSTEM FOR
MICROGRID BASED (WIND-PV-BATTERY)

MASTER'S THESIS

Abrar AHMED
(Y1913.300017)

Department of Electrical & Electronic Engineering
Electrical and Electronics Engineering Program

Thesis Advisor: Assoc. Prof. Dr. Murtaza FARSADI

August, 2021

ONAY FORMU



DECLARATION

I hereby declare with respect that the study “Energy Management For Small Scall Microgrid”, which I submitted as a Master thesis, is written without any assistance in violation of scientific ethics and traditions in all the processes from the Project phase to the conclusion of the thesis and that the works I have benefited are from those shown in the Bibliography.(.../.../20...)

Abrar AHMED





To God, who continues to guide me and give me strength throughout all challenges.

To my dear parents, who taught me to believe in myself.

To my good friends, who were there for me in the most difficult moments.

FOREWORD

First of all, I would like to express my endless gratitude to ALLAH for being who I am right now and helping me to find patience, strength with in myself to complete this thesis.

I would also like to thank my family not only for encouraging me to go abroad for Master's degree, but also for teaching me to chase my dream sand never give up. I can not express how grateful I am for having such a loving family that always believes in me. Moreover, my family is my source of inspiration and engine that helps me to improve and move on. I can not mention the patience and support that they showed with in this period of my life. Behind of any my success there is a hard work of my dear parents.

I feel very fortunate to have Assist. Prof. Dr. Murtaza Farsadi as my supervisor and want to express my appreciation for guiding me with in whole research process in a patient and effective manner. Assist. Prof.Dr.Murtaza Farsadi is not only professional in his area, but a person with a grea the art that keep sencouraging the students.

I would like to thank chairman of Electrical & Electronics Engineering Department Prof. Dr Eylem Gülce Çokerfor continuous support and understanding during research period. Finally, I would like to acknowledge the important contribution of Istanbul Aydin Universitytomy life not only from academic perspective but helping to meet great people that inspire, challenge, support and motivate me.

August, 2021

Abrar AHMED
(Electrical & Electronics Engineer)

TABLE OF CONTENT

	<u>Page</u>
FOREWORD	iii
TABLE OF CONTENT	iv
ABBREVIATIONS	vi
LIST OF FIGURES	vii
LIST OF TABLES	viii
ABSTRACT	ix
ÖZET	x
1. INTRODUCTION	1
1.1 Background	1
1.2 Motivation of the Research	4
1.3 Thesis Aims & Purposes:	4
1.4 Limitations:	4
1.5 Methodology:	4
1.6 Methodology	8
1.7 Definition of Microgrid	8
1.8 Reason for Microgrid	9
1.9 Proposed Modes of Operations	10
2. LITERATURE REVIEW	13
2.1 Basics of the Microgrid Network	13
2.2 Correlation b/w a regular network &Microgrid	13
2.3 Fundamentals of Microgrid	14
2.4 Microgrid benefits	15
2.5 Technical Impacts Of Microgrids.....	16
2.5.1 Changes in network voltage	16
2.5.2 Increase of network fault levels	16
2.5.3 Power quality:	16
2.5.4 Protection:	17
2.5.5 Stability:	17
2.6 Types of Microgrid:	18
2.7 Basic Components in Microgrid [5]:.....	18
2.7.1 Local generations:	18
2.7.2 Consumption:	19
2.7.3 Energy storage:	19
2.7.4 Main connection point (PCC):	19
2.8 Connection of Microgrid to buses:.....	19
2.8.1 Micro network connection to AC Bus	20
2.8.1.1 Inverter	20
2.8.1.2 Advantages:.....	20
2.8.1.3 Disadvantages:	21
2.8.2 Micro network connection to DC Bus:	21
2.8.2.1 Dump load:.....	21

2.8.2.2 Advantages (Ilić&Zaborszky, 2000) [7].	22
2.8.2.3 Disadvantages	22
3. PHOTOVOLTAIC DESIGN	23
3.1 Solar Power	23
3.1.1 The unit of PV system:	23
3.1.2 DC-AC converter (Inverter):	23
3.1.3 Grid network:	24
3.1.4 MPPT:	24
3.2 PV Cell Equivalent Circuit	26
3.3 Determining the load profile in a village:	26
3.4 Photo Voltaic System Designing For Micro Grid:	27
3.5 Power Out Put Of Wind Turbine:	28
3.6 Selection of swept area of the blade for micro grid and Calculation of turbine diameter:	29
4. MICROGRID CONTROL	30
4.1 Control including communication	30
4.2 Control without any communication	31
4.3 Microgrid control layer	31
5. RESULTS AND DISCUSSIONS	33
6. CONCLUSION	38
REFRENCES:	39
RESUME	42

ABBREVIATIONS

CAN	: Control Area Network
CSU	: Current Sensing Unit
DC	: Direct Current
DFT	: Discrete Fourier Transform
DG	: Distributed Generator
DSP	: Digital Signal Processing
ESS	: Energy Storage System
FCL	: Fault Current Limiter
FESU	: Flywheel Energy Storage Unit
FHES	: Fuel Cell, Hydrogen Tank and Electrolyzer System
FPGA	: Field Programmable Gate Array
FQB	: Frequency Reactive Power Boost
IPEM	: Integrated Power Electronics Module
LC	: Local Control
MCC	: Micro Grid Control Center
MG	: Micro Grid
PCC	: Point of Common Coupling
PoC	: Point of Coupling
SKIIP	: SEMIKRON intelligent integrated power
SOC	: State of Charge
SSFCL	: Solid State Fault Current Limiter
SST	: Solid State Transformer
VPD	: Voltage Power Droop
VSC	: Voltage Source Converters

LIST OF FIGURES

	<u>Page</u>
Figure.1.1: World energy consumption by renewable sources [6]	2
Figure 1.2: Global public support for different energy sources [2].	3
Figure 1.3: Grid connected hybrid system at common DC bus [3].	6
Figure 1.4: Grid connected hybrid system at common AC bus [3].	6
Figure 1.5: Stand-alone hybrid system at common DC bus [3].	7
Figure 1.6: Stand-alone hybrid system at common AC bus [3].	7
Figure 1.7: Hybrid system with AC Microgrid [3].	8
Figure 1.8: Mode of operation [46].	11
Figure 2.1: Centralized electricity General architecture view	14
Figure2.2: Grid connected to DC bus [47]	22
Figure3.1: Photovoltaic system (PV) schematic circuit [48]	23
Figure 3.2: Operation of the Photovoltaic (PV) system.	25
Figure 3.3: Current VS Voltage & Power VS voltage curves forPV cell [49].	25
Figure 3.4: Equivalent circuit of solar cell [49].	26
Figure 4.1: local and centralized controller for communication	32
Figure 5.1: The proposed energy management system for the hybrid system.	33
Figure 5.2: Solar conversion system with an MPPT controller	34
Figure 5.3: Wind system with an MPPT Controller.	34
Figure 5.4: Flowchart of P&O based MPPT Algorithm	35
Figure 5.5: Irradiation change to represent all possible scenario.	36
Figure 5.6: Battery state of charge (SOC).	36
Figure 5.7: Voltage at the DC bus.	37
Figure 5.8: Voltage at the AC bus side	37

LIST OF TABLES

	<u>Page</u>
Table 3.1: Electric Appliances ratings	26
Table 5.1: Parameters for Wind-Solar and battery based small microgrid.	35



ENERGY MANAGEMENT & CONTROL SYSTEM FOR MICROGRID BASED (WIND-PV-BATTERY)

ABSTRACT

For the future of our power system, the most important part is the microgrid system. The two types of renewable energy sources wind energy and solar energy system are considered in this thesis. These renewable energy sources (RES), wind energy, and solar energy are connected in parallel connection. The better performance of the system can be taken, by modifying the existing system topology. This thesis, includes modelling and control, of PV energy, and wind energy systems. Microgrid is the concept of integration large amount of micro sources without being disturbed the main utility grid. In the hybrid microgrid system there are PV and wind energies systems supplying to AC and DC buses. A back up battery storage system is connected with a DC bus in an emergency conditions. The control of the RES sources; wind energy and solar energy is done using an MPPT controller to track out a maximum power from these sources. The microgrid system may operate in grid connected and isolated modes of operations depends upon the requirement of power output. The DC sources are connected to the DC bus from where the DC loads are feed from it. The dynamic characteristics of the wind speed and solar irradiations are considered in model.

Keywords: *RES, MPPT, PV system*

MİKROGRİD TABANLI ENERJİ YÖNETİM & KONTROL SİSTEMİ (RÜZGAR-PV-AKÜ)

ÖZET

Güç sistemimizin geleceği için en önemli kısım mikro şebeke sistemidir. Bu tezde yenilenebilir enerji kaynaklarının rüzgar enerjisi ve güneş enerjisi sistemi olmak üzere iki türü ele alınmıştır. Bu yenilenebilir enerji kaynakları (RES), rüzgar enerjisi ve güneş enerjisi paralel olarak bağlanır. Mevcut sistem topolojisi değiştirilerek sistemin daha iyi performansı alınabilir. Bu tez, PV enerjisi ve rüzgar enerjisi sistemlerinin modellenmesini ve kontrolünü içermektedir. Mikro şebeke, büyük miktardaki mikro kaynakların ana şebekeyi bozmadan bütünleştirilmesi kavramıdır. Acil durumlarda bir yedek pil depolama sistemi bir DC bara ile bağlanır. RES kaynaklarının kontrolü; rüzgar enerjisi ve güneş enerjisi, bu kaynaklardan gelen maksimum gücü izlemek için bir MPPT denetleyicisi kullanılarak yapılır. Mikro şebeke sistemi, şebekeye bağlı ve izole çalışma modlarında çalışabilir, güç çıkışı gereksinimine bağlıdır. DC kaynakları, DC yüklerinin beslendiği DC barasına bağlanır. Modelde rüzgar hızının ve güneş ışınlarının dinamik özellikleri göz önünde bulundurulmuştur.

AnahtarKelimeler: *RES,MPPT,PVsistemi*

1. INTRODUCTION

The motive of this thesis is described in this section of the thesis.

In the current trend Renewable energy sources are good-looking options for energy supply residences where it is impossible to connect to the utility network or it is too expensive. Whom Electricity distribution technology is stepping into the next period, several developments is obvious will alter the power supply needs. Constantly growing consumption of electrical energy the rising cost and depleting nature of fossil fuels, as well as the deteriorating international. The environment has created a growing interest in green energy production systems. As the mandate for electrical energy is growing by the time, renewable energy sources drew the world's attention due to the joint depletion of fossil fuels [1].

1.1 Background

The energy gained from the natural sources like sun, wind, etc. is called the renewable energy sources. They rich source of energy and cannot be depleted by their increasing use in our daily life [2]. The four areas of energy sectors uses Renewable energy as they are electricity generation, air and water heating / cooling, transport and rural (off-grid) energy services [3].

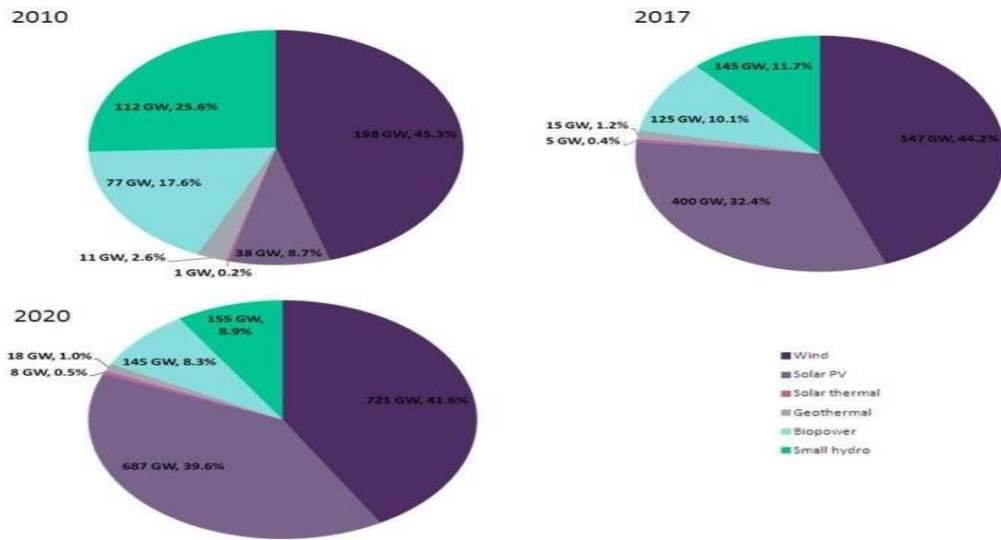

Figure.1.1: World energy consumption by renewable sources [6]

According to the REN21 report (2020), renewable resources contributed 19.2% to people. 23.7% for international energy consumption and electricity production in 2014 and 2015, annually. This energy consumption is divided into 8.9% and 4.2% of those returning from the ancient biomass energy (modern biomass, energy and solar heat), 3.9% hydroelectric and 2.2% electricity wind, solar, geothermal and biomass. Global investment in renewable technologies. In 2015, countries such as China, wind, water, solar and biofuels. There are 7.7 million renewable energy jobs in the world the industry where solar photovoltaics is the most important renewable employer. Since 2015, half of all electricity installed in the world can be renewables sources [1].

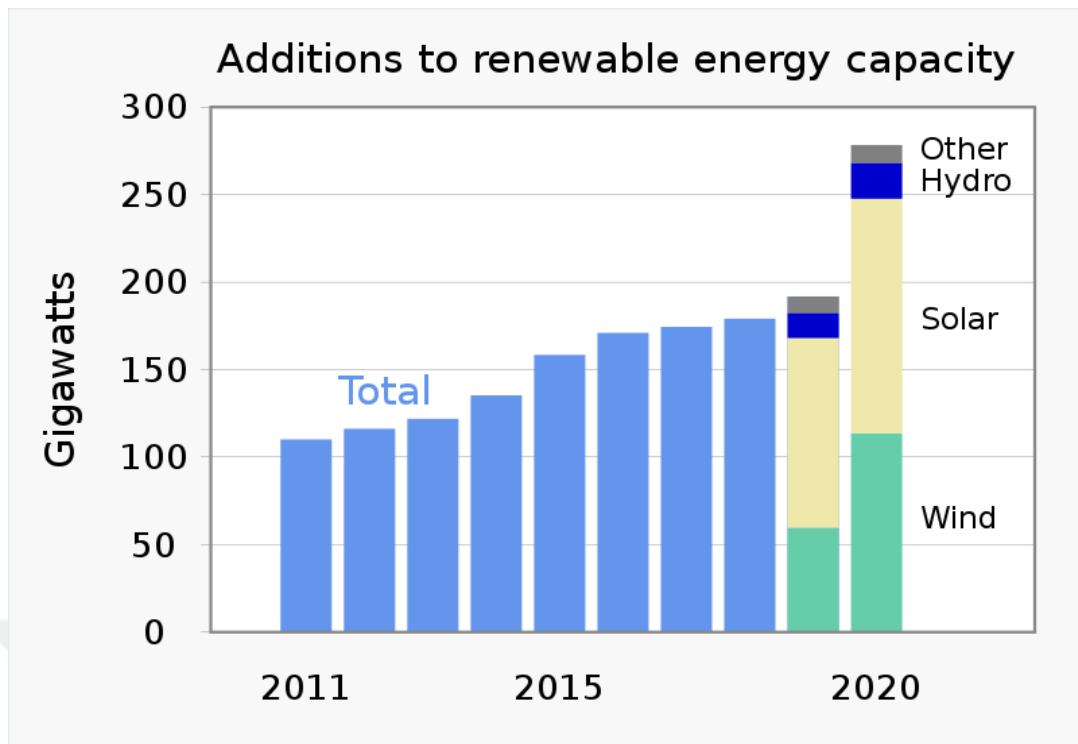

Figure 1.2: Global public support for different energy sources [2].

A sustainable energy source comes from common recharging procedures never receives directly from the sun or from the heat produced in different forms deep between the planets. It is the power and heat created within the definition solar, wind, marine, hydroelectric, biomass-based energy entities and biopowers and matter component is derived from sustainable assets. Sustainable energy source assets are very important open doors for the energy intensity available in large land areas in accordance with energy source options. States dealing with exceptionally limited states.

In the 19th century, before coal, almost all energy could be renewed are produced. Not surprisingly, it was the oldest known use of renewable energy in the ancient style. The biomass that will ignite fires dates back 790,000 years. The use of biomass for fireplaces has failed A few thousand years later, with 200,000 a day 400,000 years ago. Probably the second oldest use of renewable energy is the use of energy wind to rub the ships on the water. This observation can be traced back to 7,000 years agoShips on the river [1] in history. The first sources of ancient renewable sources. The energy was human labor, animal power, water power, windmills crushing grain biomass. The graph of energy

consumption in the United States until 1900 shows that oil and fossil fuels are the same. The importance of wind and sun in 1900 as in 2010.

1.2 Motivation of the Research

There is ongoing research on microgrids and a lot of research has been done. The feasibility, efficiency and benefits of microgrid are tested by conducting these researches.

1.3 Thesis Aims & Purposes:

This thesis aims to modify and design photovoltaics in a micro grid system. Wind turbine. The selection is made in accordance with the requirements of the micro network and control methods used for different modes about contact. The purpose of this work is to analyze the hypothesis arising from the hypothesis. To ensure that the background of this work and the findings of this analysis can provide new information perspectives that help revise standards.

1.4 Limitations:

Micro network systems with wind turbine generators and PV cells are mainly concentrated here thesis work. In all sizes, the maximum dimensions are in the building permits. For this reason, a turbine with a height of 20 m and a rotor diameter of 3 m is considered.

1.5 Methodology:

Interaction of two or more renewable generation sources, such as wind energy, the photo provides local load power with voltaic power, electric charge and micro turbine generator or network / micro network connection Hybrid Power Systems. According to the characteristics solar and wind energy, electricity generation of the PV array, as well as wind. The turbine corresponds to a higher combined power generation reliability compared to the power produced by an individual supply. You need a large battery bank. Most power for the load is taken from the wind and photo voltaic system.

Recently, DC networks have been revived due to development and deployment the advantage of renewable DC energy sources and commercial, industrial and DC loads residential applications. There is a DC microgrid to integrate with various distributed generators was proposed. However, AC sources must be converted to DC before they can be connected to DC Network and DC / AC converters are required for conventional AC loads. When the power is completely gone provided with renewable energy sources. HV long-distance transmission is no more necessary. AC Microgrids are offered to facilitate the integration of renewable energy sources AC systems. However, the DC output power of the photovoltaic (PV) panel must be converted AC is connected to an AC network using DC / DC amplifiers and DC / AC converters. In the AC network, there is a need for AC / DC and DC / DC converters installed for various home and office installations provides different DC voltage.

To reduce many processes, a hybrid AC / DC micro network has been proposed in this paper facilitate reverse transformations and various combinations in an individual AC or DC network renewable AC and DC sources and loads to the power grid. Coordination control schemes It is proposed to use the most renewable energy sources among the various modes To weaken the power transmission between AC and DC networks and ensure stable operation both AC and DC networks under changing demand and supply conditions after a hybrid network works both network-connected and island mode. Advanced power electronics and control The technologies used can make the future network more intelligent.

Due to the interruption of solar and wind energy and its unpredictability in nature, higher penetration of species into the existing network can lead to high technical problems, especially for weak grids or stand-alone systems that are improper and do not have sufficient storage capacity. By combining the two renewable sources in an optimal combination The variability of solar and wind sources will be partially addressed and the overall system it is more reliable and economical to manage. There are several configurations that A offers consider the state of both grid-connected and independent hybrid solar and wind art systems.

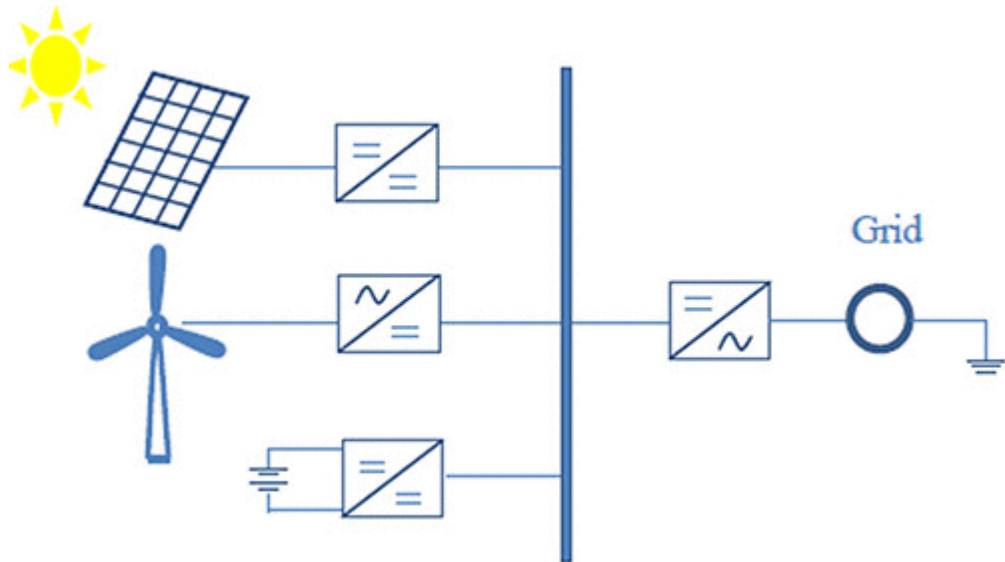

Figure 1.3: Grid connected hybrid system at common DC bus [3].

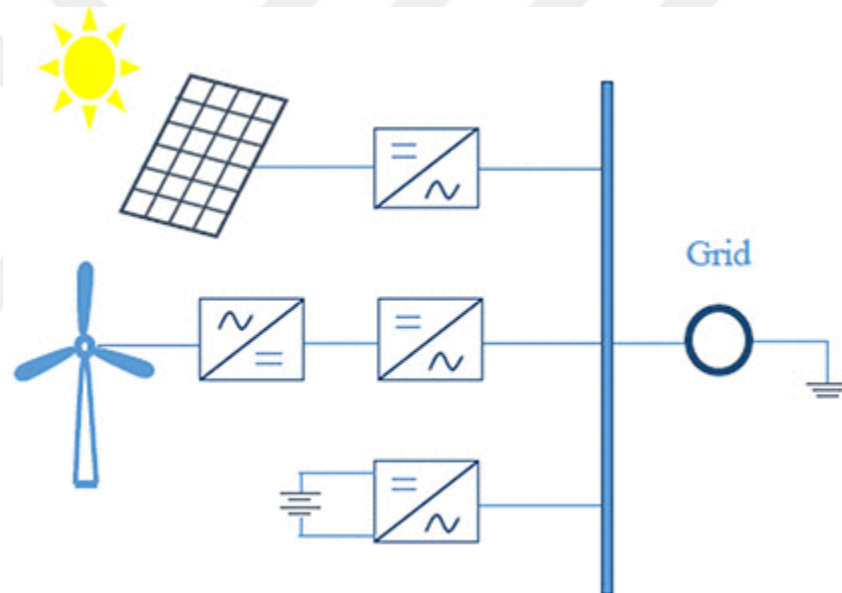

Figure 1.4: Grid connected hybrid system at common AC bus [3].

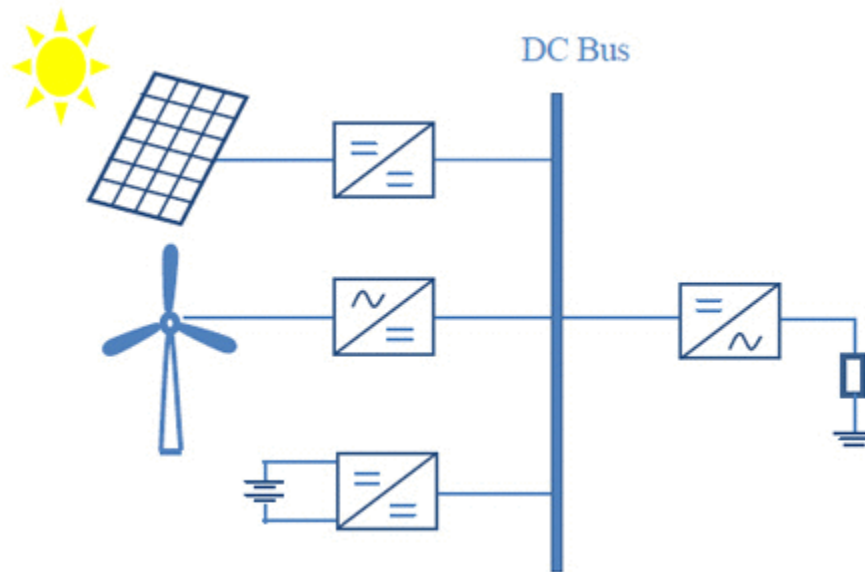

Figure 1.5: Stand-alone hybrid system at common DC bus [3].

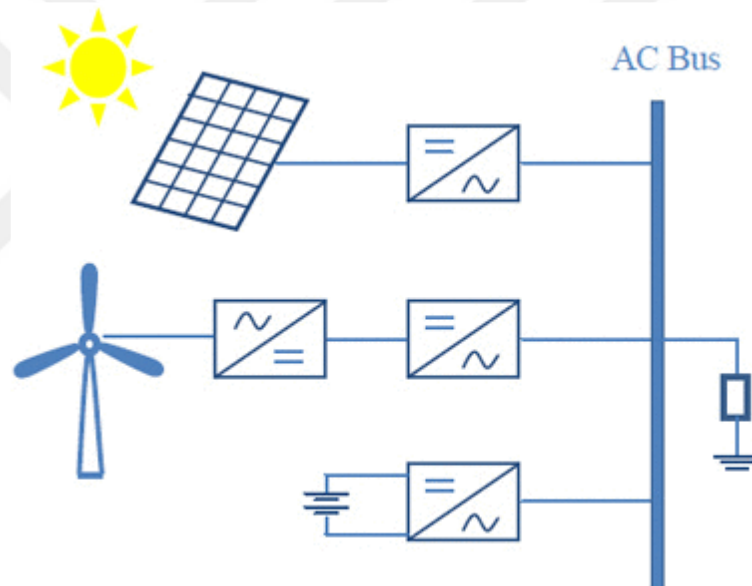

Figure 1.6: Stand-alone hybrid system at common AC bus [3]

Voltage and frequency fluctuations and harmonics are a major energy quality problem for both network-connected and stand-alone systems that have a greater impact in the case of a weak network. It can be Proper design, advanced fast response control devices and large scale solution optimization of hybrid systems

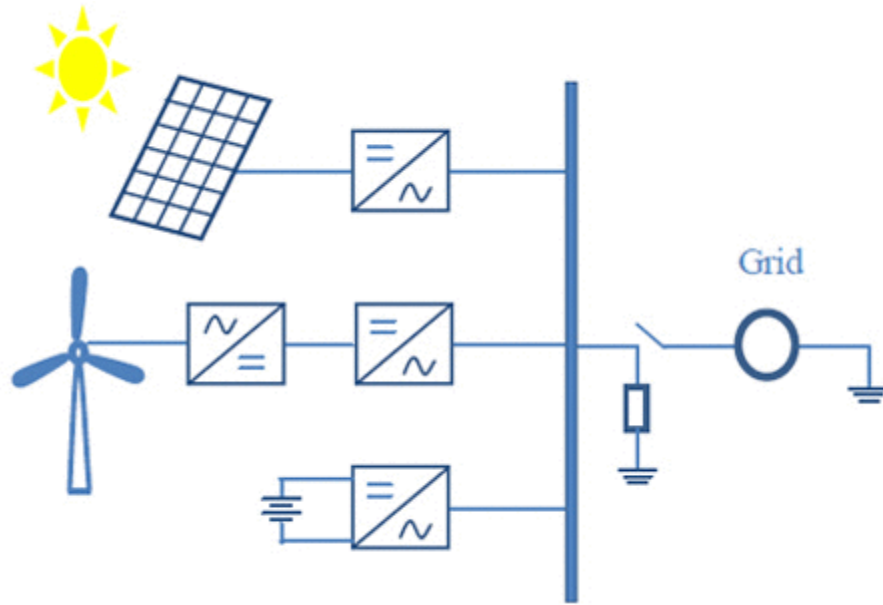

Figure 1.7: Hybrid system with AC Microgrid [3].

Microgrid is a new concept in power generation. The microgrid concept was a group micro sources that act as a single managed system that provides both loads and power. Some models of heat can describe Microgrid components.

1.6 Methodology.

The following steps are proposed for the application of the microgrid system:

- Renew The first choice of power supply system as a renewable energy source according to the demand and availability of the access source;
- Renew Combine all these sources as renewable energy sources in Microgrid;
- Control systems and energy storage
- Power control in microgrid.

1.7 Definition of Microgrid

The microgrid is the concept of a collection of working loads renewable energy sources a controlled system that has every power and heat in its native space. This idea as a new paradigm to describe the work of the distributed generation [3], [4]. Small Interest group sources for microgrids are small (100 kW) units with electricity interfaces. These resources are posted on customers' websites.

They have a low price and low voltage high reliability with low emissions. Power management and physical sciences Adaptation required for microgrid concept. Properly designed electrical electronics and controllers ensure that Microgrid meets customer requirements utilities said they did not plan Microgrids' features in a centralized manner communal).

- Not sent to the center.
- Normally less than 50-100 MW.
- Generally depends on the distribution system.

The application of a microgrid can be as simple as installing a small power generator Produce spare power on the electricity consumer's website or it can be very difficult highly integrated system with electricity grid, consisting of electricity generation, energy storage and energy management systems. Each consists of a technology portfolio Provide the aspect and demand side to be established where the energy is or near the situation being busy. Microgrid devices offer greater local power management capabilities delivery and consumption. In addition, they change many economical uses of leftover heat Combined heat and power applications like a CHP that increase capacity and reduce emissions.

1.8 Reason for Microgrid

Recently, the traditional structure of a large power grid offers various advantages. Great The devices that produce it are often economical and are only managed with a comparatively minor amount staff. A HV transmission line which is interconnected, which allows the generator backup reducing demand, building the most economical production plant at certain period and much power will be transported with a lower limited power losses over a huge distances. The system is often considered for one-way power flow and is sized to accept client electrical loads. Though, various effects have come together over the years Micro network circuits [1]. The politicians who promote microgrids are:

- Reduction of gas emissions (mainly CO₂).
- Energy efficiency or rational use of energy.

- Regulatory or competition policy.
- Diversification of energy sources.
- National power demand.

The reference [1] listed other reasons, but special attention was paid to the commercial subject

considerations such as:

- Availability of module production facilities.
- Ease of finding a site for small generators.
- Short construction period and low capital costs of smaller plants.
- Production can be placed closer to the load, which can reduce transmission costs.
- Technical effects of micro networks on the distribution system.
- changing and regulating mains voltage

1.9 Proposed Modes of Operations

In the coming years, all settlements will have their own uninterrupted renewable energy Systems that have the potential to understand basic operating modes such as networking mode and island mode. This method will be able to produce smooth, continuous transition between these modes through exploitation. Landing detection and The procedure of the re-synchronization algorithm would be something complicated. Each switching mode. In the below figure 8 the 2 modes of operation are designed and shown, islanded and grid connected. Once the ability is connected away from the utility network the system switches to island mode and after the ability is acquired from the utility network the system can synchronize and the utility will connect to the network. Power output

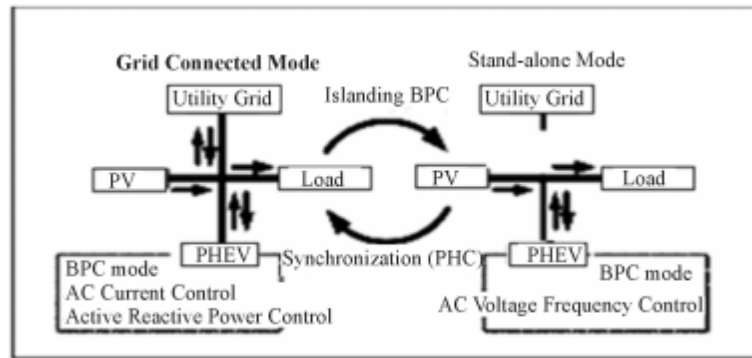

Figure 1.8: Mode of operation [46].

The following paragraph explains the working principle of these regimes. There are frequent varies according to weather conditions and wind speed. Wind depending on these conditions and solar systems work. These systems must be acceptable. This means that these systems operating parameters should be adjusted according to changes in climatic conditions. These parameters are quite unexpected. You can't even expect these settings operators are within the network and cannot predict wind and sunlight conditions for photography voltaic cell farms accurately. The output of these systems changes forever and must be the operator Extremely careful within the network. Still, there are many problems that are difficultresolved.

In network management, voltage and frequency as a result of seconds are very important network operators continue to take care of frequency and voltage fluctuations for up to a minute interline transmission system. Any of these settings can be damaged if not controlledthe system is further as a network-based tool. If you can be an operator Turn on generators to power the microgrid (can be moving or reactive) power is released from value not purchased for customers, but is used to balance specific and expected wattage power forecast which is important to reduce the change frequency and voltage in the network. These necessary services must be provided by the network was needed once.

Typical services are:

- Frequency change occurs rapidly and should be monitored. These changes may occur device - Automatic generation control (AGC) signals the network generators.

- In case of failure of main generators, some generators should be in backup generators must supply power for at least 12 min. When fault occur on main principle generator then a backup generator will feed to the load or when the main generator is out of service.
- Few generating stations have same principle of working as the backup generators but they have slow response time,
- Generators used for reactive power when the mains voltage drops Desirable voltage in the network when needed.
- Micro network generators should be available to restart the power system in case of load shading lasts a long time



2. LITERATURE REVIEW

Microgrids and some are currently undergoing significant research model designs have been proposed in the article, for example, [3], [4], [6], [7], [8], [5]. Although The fact that a Microgrid segment is really new, the network in general of course not. At the point where several sources are associated with the Microgrid form Network behavior is eccentric. The situation is to show and re-create the network Given the ultimate goal of building a proper control network, it is the heart of miniaturization scale network research. These days, several research teams are investigating from afar Practicality and advantages of microgrids. There are several problems incorporates management of unequal network loads and noise. It works This does not mean solving such problems, but rather the demonstration of Microgridto investigate the reaction of a temporary and ruthless situation.

2.1 Basics of the Microgrid Network

Basically, a Microgrid covers a combination of numerous assimilated energy savings sources; The power from these sources is collected, prepared, and disseminated for care demand is loaded. At the point where the control elements come into contact with the miniature scale energy When building a single element, its operation requires a control network. Such a control network required to ensure adaptability, maintain a special power system and power quality.

2.2 Correlation b/w a regular network &Microgrid

Deviations between the normal mains and the Microgrid are very common (Chowdhury et al., 2009):

- The ability to generate power from micro sources is smaller when it is different with an ordinary power plant that can deliver.

- Micro network enterprises are typically close to the buyer base, which hints at fewer failures on TLs. Micro networks are extremely productive up to voltage supply and repeatability profile and instead of transmission and concentrated power plant Refer to the figure below.
- In a microgrid, it is better to source to zones where it is nearly non-existent corresponds to the national cage
- The power outage procedure is usually difficult. Requires speed Intercession is generally physical and gradually combined with a Microgrid technique The rebuild procedure is simple, given a number of controllable factors

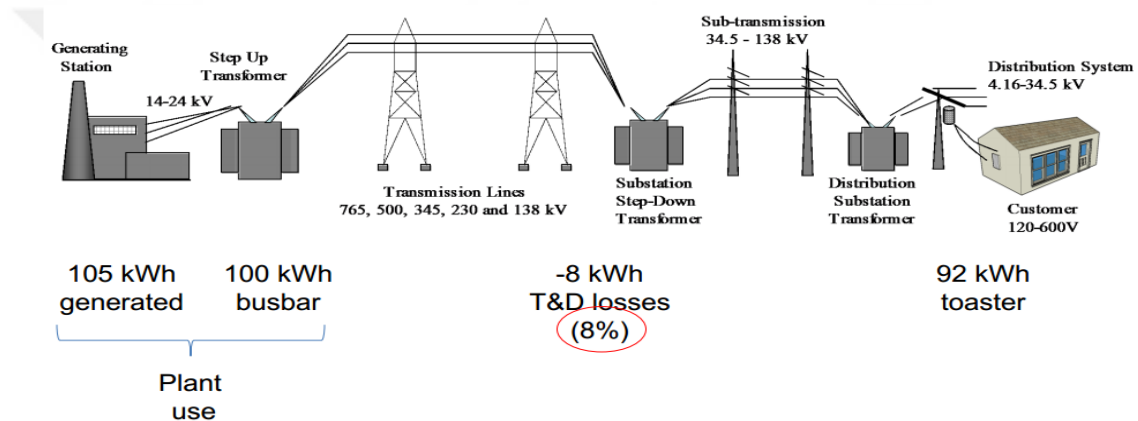

Figure 2.1: Centralized electricity General architecture view

2.3 Fundamentals of Microgrid

The DG network of low and medium are growing rapidly worldwide. Managed by incoming stable, irregular generators; power modules, wind and (PV) photovoltaic network (Lee et al., 2004; Chowdhury et al., 2009). Which are being used regularly intensification the utility network between the highest clock collection compared to the lack of time from energy. In the same way, they can offer help to control in case the main network cage falls straightFrom the evening onwards, the idea became even more interesting in places where a movement path was gathered the loads that make up a bunch, collected with the equivalent units of DG, make up and being called as a Micro network. The main utility is connected with the small power generators.A technique in which a small generator set is designed to lessen the influence of network actioneach

micro source connected to each other. Arrange due to an error for a darkness in the network when the utility is identified in the cage, it will effectively disturb and sealed down the generator set, Unlike the Microgrid, the power is turned off when the network system is turned off The microgrid will be methodically separated from the cage arrangement and will work autonomously the utility provides energy to the neighborhood stack when it returns to typical.

2.4 Microgrid benefits

The growth of the microgrid fills as a method to take a favorable position In different networks, this is explained under (Chowdhury et al., 2009):

- When it comes to natural hazards, a Microgrid reduces pollution by using a micro source providing little or nil discharge.
- Microgrids works in equivalent with the Grid; they strengthen them by fighting special loads utility network. An additional limit set by microgrids can help prevent overload national network conditions and power outages.
- There is a reduction in the construction and comparison of economically long transmission lines Transmission. Local effective installation of microgrid networks with minimal effort forgives basic expenses and relocation accidents. Micro networks help in addition reduces the use of fossil energy.
- Guarantees uninterrupted loads by operating in both network and island mode. This makes it stronger and transfers superior energy to the main loads.
- Microgrids use thermal energy sparingly when using combined heat and power. This A simple procedure to perform with a Microgrid micro source. Can be micro welded sent closer to heat and electrical loads to increase energy capacity.
- Microgrids use thermal energy sparingly when using combined heat and power. This is it A simple procedure to perform with a Microgrid micro

source. To increase energy Due to its efficiency, micro welding can be transmitted closer to heat and electrical loads

2.5 Technical Impacts Of Microgrids

2.5.1 Changes in network voltage

Each delivery service has an obligation to supply power to its customers at the same voltage predetermined breaking point. This precondition often determines the plan and costs rolling circuit so procedures have been established to do this over the years Maximum use of mastering schemes to provide customers with the required voltage range. Some circulating utilities use more advanced control of load crane changers winding transformer by controllers in the feeder and including today's use the flag was amplified by calculating the voltage across the modified capacitor in the feeders [9]

2.5.2 Increase of network fault levels

Most Microgrid plants use turning machines, which will be added to the system sin levels. Both registration and synchronous generators will increase the level of guilt spill network despite their behavior under supported sin conditions is a contradiction. By providing an impedance between them, the level of sin obligation can be reduced At the expense of expanding the generator and the system with a transformer or reactor failures and wider voltage types in the generator [10] [4]. In urban areas where the existing accusation methodology, switching device rating, fault extension level can be a real obstacle to the development of Distributed Generation.

2.5.3 Power quality:

Two parts of energy quality are generally considered important: (i) transient voltage types and (ii) the peak voltage of the system voltage [4]. Microgrid can be transient generally if a large current varies between the junction and the system, a small lag from the system the generator is allowed to disconnect. It is important to achieve maximum tension in this way species that limit the range of light. Large stack gaps can cause voltage variations in addition source change [11]. Microgrid units can likely lead to undesirable transient types of voltage in

the neighborhood control network. Step-by-step change of data With Microgrid units and Microgrid with permanent gaps Voltage control devices in the power supply can bring significant voltage types [9]. The Provides more potential for voltage types due to the independent operation of microgrid devices load the disturbing effects of the instantaneous DG inverter. In that case the impedance of the inverter is high enough that it will bring adjustments in the current period noticeable changes in voltage drop and therefore the AC supply voltage will be discharged. On the other hand, weak connections in network mixing mode allow transient voltages occurring species bring lower rates than the independent regime [10].

2.5.4 Protection:

Different different parts of the microgrid warranty can be recognized [1]:

- Protection of period gears from internal defects.
- Protection of the spread of accused persons is provided by the criminal flows provided by the organization Micro networks.
- Island or current loss insurance.
- Impact of Micro Networks on Existing Dispersion Network Insurance.

2.5.5 Stability:

For Destroyed Generators, the goal is to assassinate new ones sustainable energy sources tend not to think about the transient strength of the generator awesome necessity. If there is a fault in the appropriation system All that is lost to stop the system voltage and Distributed Generator trips is short period of time. Microgrids will monitor speed and stumble on internal safety. The control circuit in the microgrids will then sit tight for the condition of the system is rebuilt and eventually restarted. Interestingly, if a DG is seen as an offer to help The power grid, then its transient reliability is of paramount importance. Both tensions or the strength of the potential point may be noticeable based on the conditions.

2.6 Types of Microgrid:

- Campus Environment / Institutional Micro Networks

The ground concentration was completely present in the near future with different loads They are located in dense geology, which is difficult for the owner to control them.

- Remote "Off-Network" Micro Networks

These Microgrids never communicate with Macrogrids and generally operate in an island mode conditions in terms of mild matter or topographic position. Generally, "offline" Microgrids are unique zones that are far from any transmission and transport foundation and in this way the utility has nothing to do with the network.

- Military Base Micro Networks

These Micro Networks are typically sent efficiently with both physical and digital concentrates Security for military administrations, given the ultimate goal of providing reliable power Depends on the microgrid.

- Commerce and Industry (C&I) Microgrids

These types of micro networks are growing rapidly in North America and the Asia-Pacific; be as it is The lack of known models for this type of Microgrids shows them Universally, the main purpose of building a modern Micro Network is power supply safety and unshakable quality. There are many forms of intervention that interfere power supply can lead to high-income accidents and long start-ups.

2.7 Basic Components in Microgrid [5]:

2.7.1 Local generations:

Provides the customer with a variety of cycle sources that promote strength. These are the sources divided into two noteworthy assemblies - conventional life sources (e.g., diesel generators) and inexhaustible cycle sources (e.g., wind turbines, based on sunlight).

2.7.2 Consumption:

It basically refers to energy-consuming components from one gadget to another lighting, heating regulation of structures, work centers, etc. At the expense of controllable loads, power consumption can be adjusted as the system is popular.

2.7.3 Energy storage:

Microgrid lifecycle collection can have many capabilities, such as warranty Energy quality, including continuous productivity correction, repetition and voltage control energy sources provide boosting energy to the grid and cover a critical portion of the cost improvement. It combines all electricity, weight, gravity, flywheel and heat collection of innovations.

2.7.4 Main connection point (PCC):

This is the point at which a Microgrid in an electrical circuit is connected to a mains. [7] Non-PCC microgrids are usually called limited Microgrids at the expense of distant places (e.g., distant groups or distant mechanical directions) connection to the main network cannot be made because it is both private and impossible financial requirements.

2.8 Connection of Microgrid to buses:

Each energy source produces alternative energy signals, ie photovoltaic cells produce DC and wind produces AC. They need to adapt. This is called adaptation The connection Binding can be done in two different ways: AC or DC. Can be used as part both in-network and off-network, and in mixed design. The number of parts during AC-connection and DC-connection is almost the same, but the only difference the discharge load is used in DC and the WTG converter is used in AC-connector A WTG converter is often made with a fighter chopper with a DC-DC switch converts damaging currents and voltages into a heat-generating resistor, instead of protecting the inverter throw the load.

Depending on connection, Microgrids are divided into three types

1. DC Migrogrids
2. AC Microgrids

3. Hybrid DC and AC coupled Microgrids

2.8.1 Micro network connection to AC Bus

In AC micro network power systems, each part of the system is connected to a standard AC voltage network, for example, 50Hz, 230 / 400V, at the connection point before the local load. Expandability this is one of the main features of the system. Recently, this type of connection system has become is very popular due to the growth of decentralized power grids. With the main drawback These systems need an inverter

2.8.1.1 Inverter

The inverter, as in PV modules, is the main part for the PV connected to each network system. The energy rating is based on the most extreme production of PV-modules in this way it is a quality that changes regularly, especially for each system. The MPPT system is connected in the same box that converts DC to AC. To connect an additional power source to them the equipment must be electrically adjusted or replaced with new programming. At the exit It is likely that there will be only one MPPT for all input ports implementing new programming on the network MPPT will then bring limited power generation from the modules, and it is needed for that This is sufficient if the inverter takes extra than unique MPPT. Founded on the closed situation The search for the ideal converter leads to rules given in numerical sequence.

1. The inverter is ready for WTG, ie it has at least one additional port offered for WTG.
2. The inverter is completely empty, ie there is no tracking system.
3. The inverter has a distinct MPPT for dissimilar suggestion ports and for MPPT programming can be reprogrammed or removed.

2.8.1.2 Advantages:

1. No discharge load is required when connected to the network.
2. Expansion is possible and easy.
3. Circuit design is simple.
4. The inverter is needed to connect to the AC bus.

2.8.1.3 Disadvantages:

1. An inverter is needed and expensive.
2. Less efficient due to inverter.

2.8.2 Micro network connection to DC Bus:

In DC micro grid power systems, each component of the conversion system is a main DC-bus connected to the network with the main converter. AC / DC is needed a converter that can connect DC transmission lines where all AC generating components are available in the system. Due to the normal DC delivery method of PV modules, traditional The connection method was DC. This is the main drawback of a DC-connected micro-network system throw the load. The connection diagram is shown below.

2.8.2.1 Dump load:

The system connected to the DC bus must have a discharge load for excess powerproduction over the inverter power rate. Garbage load is part of the system with low resistance that generates heat with power. Used as part of a systemprotect the batteries from overloading or from a mains-connected network to protect the inverter. For one An off-grid system using batteries must have the same power rating as the discharge load the total capacity of the system. In a networked system, the overall supply is a measure the waste load must be exactly the same size as the difference between the applied control the power rating of the converter. For example: A network has a wind turbine and PV modules total maximum power 6 kW. Estimated power of the inverter is 3.5 kW; therefore landfill To protect the system, the load must not be less than 2.5 kW. Due to the possibility of garbageis directly related to a specific component, e.g. photovoltaic modules or wind The turbine generator must be the same size as the components of the maximum power generation. Garbage load can be used, for example, as an electric heater connected to the mains heat storage of the house. The following thermodynamic equation is used to calculate energy heat storage that can store.

$$E = C_p * m * dT \quad (2.1)$$

If the sediment load is used as a submersible heater, calculations must be made to ensure this The tank has enough power to absorb heat from the load. Suppose the cutter, connected to a heat sensor in the tank, must be installed for switching for both productions Wind turbine generator or PV-modules, when the temperature reaches 100 to.

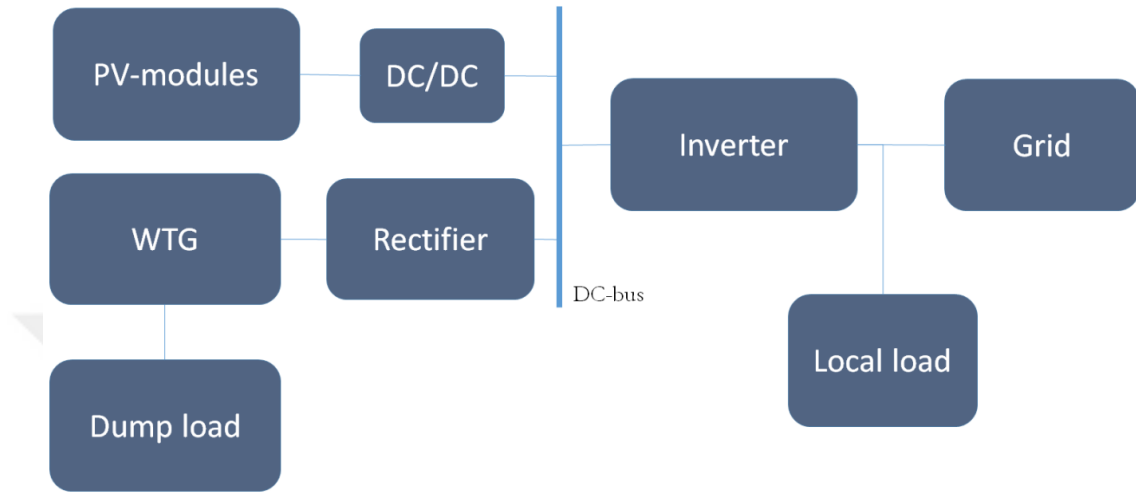

Figure2.2: Grid connected to DC bus [47]

2.8.2.2 Advantages (Ilić&Zaborszky, 2000) [7].

1. The frequency components are smaller, so the control is simple.
2. Conversion losses are less because fewer components are used.
3. DC transmission lines have less loss compared to AC transmission, ie; more efficient.
4. It is cheaper

2.8.2.3 Disadvantages

1. It is difficult to expand.
2. DC breakage is dangerous

3. PHOTOVOLTAIC DESIGN

3.1 Solar Power

In worldwide, the Photovoltaic (PV) generation systems were expected to grow significantly. The city in which they are distributed is an attractive renewable energy source for electricity generation relatively small size and quiet operation. PV-producing technologies have an advantage more units can be added to meet the load growth requirement. The main block diagram of the network The connected PV is exposed in Figure 11. The blocks of Power generation form the PV system mainly consists of:

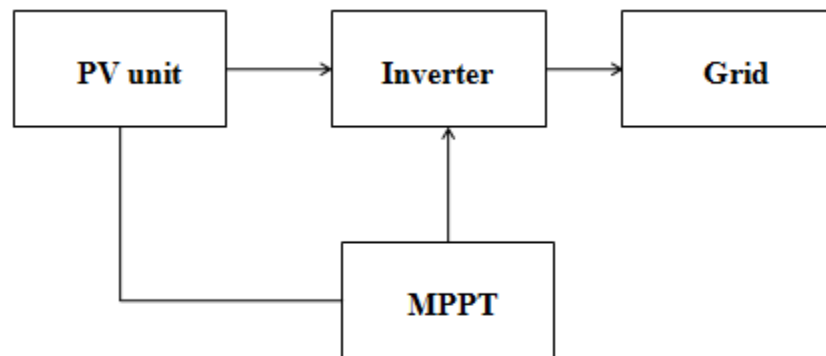

Figure3.1: Photovoltaic system (PV) schematic circuit [48]

3.1.1 The unit of PV system:

Through the process of photovoltaic emissions a PV unit which consists of multiple PV cells. The light energy from the sun will be converted into electrical energy without any other long process.

3.1.2 DC-AC converter (Inverter):

The full H-bridge converter supplying a DC voltage will convert into AC voltage across the load. A three phase inverter is used here with connected a grid and load at its output.

3.1.3 Grid network:

The grid is connected at the output side of the DC-AC converter. It will either supply and consumes power from the main grid.

3.1.4 MPPT:

To use the maximum power produced by PV modules a maximum power point monitor (MPPT) will be used with the DC-DC converter control to track out the maximum power. It (MPPT) monitors the voltage at which maximum power is always used. Ability is measured in the laboratory using I-V under standard conditions curves. Curves I-V is obtained by passing the external resistance from zero infertility.

The energy from the PV cell is the result of voltage (V) and current (I). In both open and closed circuits the power is zero under the conditions. Delivered at the same point (around the knee point) power is the most extreme. The cell current depends on the amount of light energy (radiation) falls on the PV cell and the cell temperature.

As the radiation decreases, the power decreases and the peak also moves in the right directionsol. As the temperature of the cell increases, the energy output decreases and becomes excessive the power point moves to the left again.

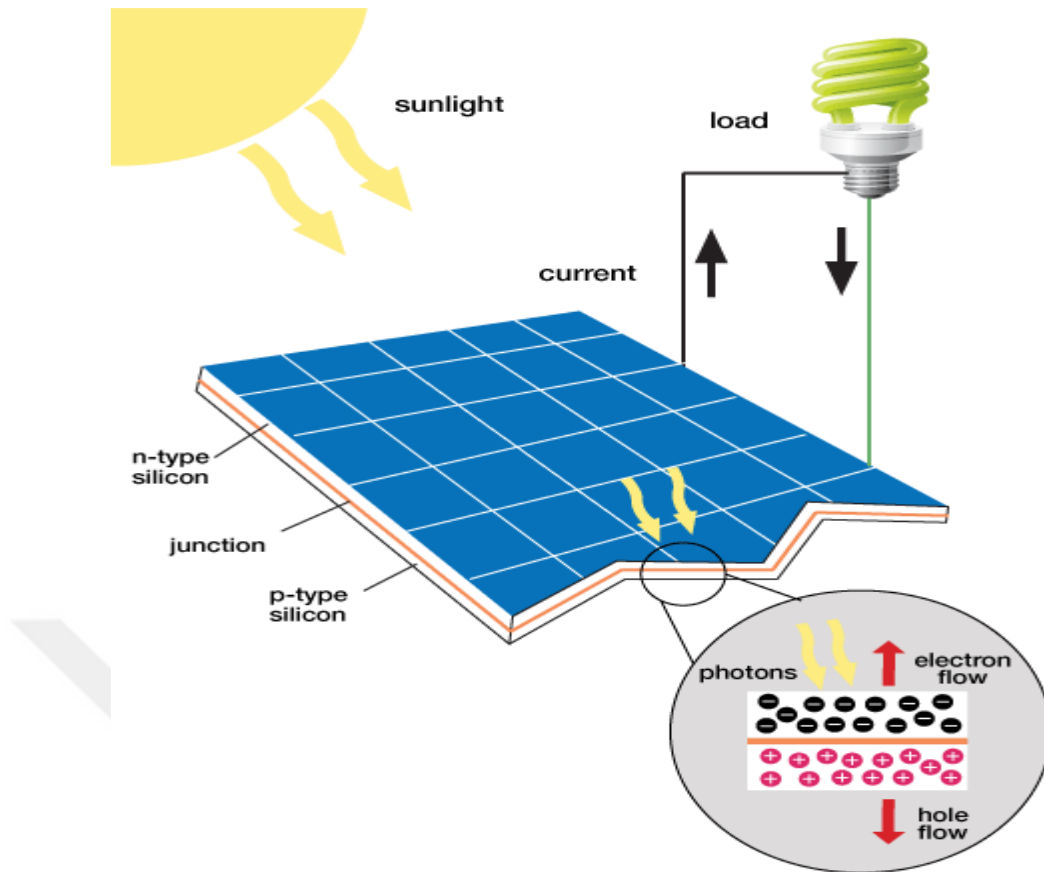

Figure 3.2: Operation of the Photovoltaic (PV) system.

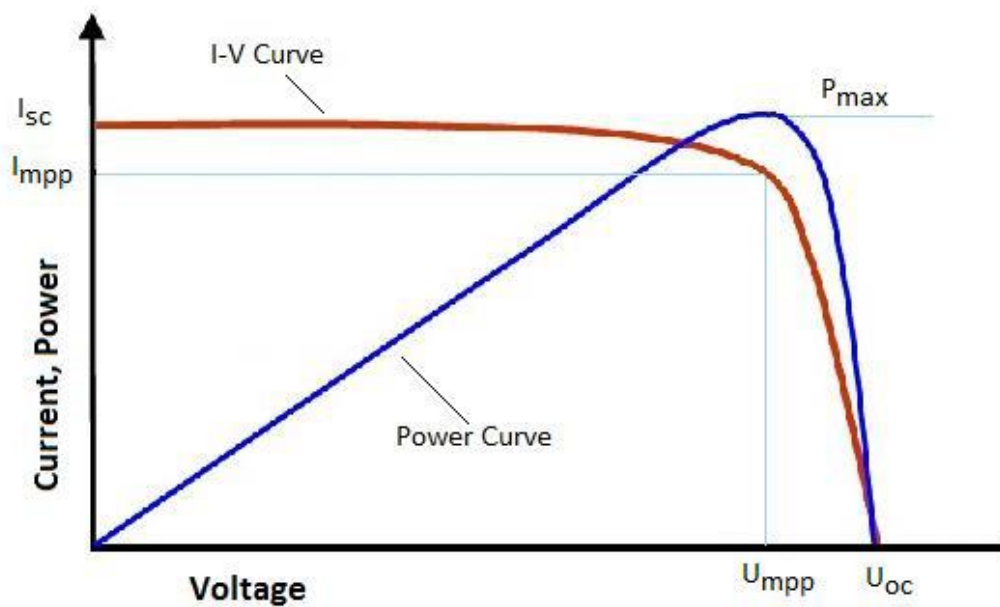

Figure 3.3: Current VS Voltage & Power VS voltage curves for PV cell [49].

3.2 PV Cell Equivalent Circuit

A pure PV cell can be designed in way that a source is connected in parallel with diode; The solar (PV) panel in our universe cannot be found as pure 100% efficient, While the shunt resistances and series resistances are connected as shown in figure 14.

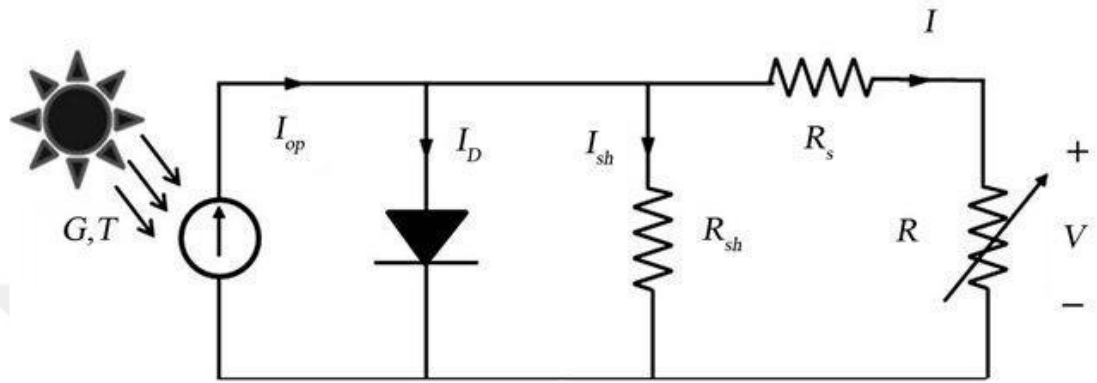

Figure 3.4:Equivalent circuit of solar cell [49].

3.3 Determining the load profile in a village:

Cargo Profile Energy Department (Engery, 2014) and perhaps there are secondary stuffs that can be establish in pastoral backgrounds. As it may be The cargo consumption shown in the table below is comparatively little in rural parts. However, it is so we thought that all homes had the same energy needs and the same pf.

Table 3.1: Electric Appliances ratings

Electrical Loads	Power ratings in (W)	Quantity Units	Time
Lamp	30	6	8hrs
Radio	70	1	5hrs
Micro wave	750	1	1hrs
Cell charging	10	2	6hrs
TV	133	2	6hrs
Refrigerator	725	1	24hrs
Water heating(120lit)	1000	1	1hrs
Ironing cloth	4500	1	4hrs

About the total number of houses like 272, then the total power output for each house will be 7.368 KW. During the peak load hours the total energy supplied to the all houses will be 2MW, which exclude the total power losses due to IR losses. The project condition is for 1 supply energy of PV system providing three-phase 398 Vac (Vrms). The modulation index of 0.866, the maximum dc voltage supplied to the inverter input is the 750 Vdc. The main output voltage of the inverter is determined by:

$$m * V_{dc} * \frac{\sqrt{3}}{2} \quad (3.1)$$

3.4 Photo Voltaic System Designing For Micro Grid:

The aim of the thesis is to model PV to get required output voltage and good performance with

respect to radiation and ambient temperature. The PV model is easy and simple.

The PV system can be determined as:

$$V_{oc} = 64.2 \text{ V}$$

$$I_{sc} = 5.96 \text{ A}$$

$$V_{mp} = 54.7 \text{ V}$$

$$I_{mp} = 5.58 \text{ A}$$

Module parameters for one module

$$R_p = 993.51 \ \Omega$$

$$T_{sat} = 1.1753 \text{ e} - 8 \text{ } ^\circ\text{C}$$

$$I_{ph} = 5.9602 \text{ A}$$

$$Q_d = 1.3 \text{ J/S}$$

Photovoltaic system design for 400 Vdc at 2 MW 10 PV systems, every of 200 kW are calculated and linked in parallel to create the 2 MWp, by initially manipulative 200 kW PV and then grow it by 10 times to become the anticipated 2MWP.

The calculation of the number of modules for required design:

$$\text{The number of series plates} = \frac{400}{54.7} = 7.31$$

0.31 fractional panels is not possible so up to 8 only

$$\text{Actual output voltage} = 8 * 54.7 = 437.6 \text{ Vdc}$$

Output current calculation:

$$P = VI$$

$$I = \frac{P}{V} = \frac{20000}{400} = 500 \text{ A}$$

$$\text{The number of panels in parallel} = \frac{500}{5.58} = 89.60$$

0.60 fractional panels is not possible so panels rounded up to 90

$$\text{Actual power} = 90 * 5.58 * 437.6 = 219.762 \text{ KW}$$

3.5 Power Out Put Of Wind Turbine:

As we know, the power output is proportional to the cubic relationship with the wind speed in proportion to the air density, in proportion to the sweeping area of the entire rotor can be combined with a mathematical expression.

$$P = \frac{1}{2} * \rho * A * V^3 \quad (3.2)$$

Where,

P is Power output of wind turbine (Watts)

ρ is Density of air (kg/m³)

A is Swept area (m²)

V is Velocity of wind (m/s)

The actual power of a turbine depends on many factors, such as the type of rotor used, friction losses, blade design - viscosity and pressure friction in the rotor blades, losses in electrical system components, and rotation caused by the rotor's air movement. These factors were summarized and analyzed by Betz, which represents the limit of quenching power known as the Betz limit. This

value is equal to 0.59, which is the maximum power that can be produced from a wind turbine. Existing wind turbines can reach a maximum of 50%, which agrees with the limit. This is the coefficient of performance of a wind turbine. The output power of the wind turbine can be changed as follows

$$P_{mean} = \frac{1}{2} * k * C * A * \rho * V^3 \quad (3.3)$$

3.6 Selection of swept area of the blade for micro grid and Calculation of turbine diameter:

Suppose 4000 Kwh more energy is needed each year and the location has the annual

average wind speed of 6 m/s. for this system the blade with swept area is calculated from

below equations.

$$E_{year} = P_{mean} * 8760 \quad (3.4)$$

$$P_{mean} = \frac{1}{2} * k * C * A * \rho * V^3$$

$$P_{mean} = \frac{400000}{8760} = 456 \text{ W}$$

$$A = \frac{P_{mean} * 2}{kCA\rho V^3} \quad (3.5)$$

$$A = \frac{456 * 2}{1.9 * 0.2 * 1.24 * 6 * 6 * 6} = 9 \text{ m}^2$$

Calculation of turbine diameter

$$A = \frac{\pi * d^2}{4} \quad (3.6)$$

From above calculations area is 9 m²

Diameter approximately equal to 4 m²

4. MICROGRID CONTROL

The control plans of the generator controls the operation of the microgrid system. The power distribution's accuracy is ensured by usage of control of the Inverter, directing the frequency of Micro Network and the magnitude of voltage for Microgrid voltage. They practice VSI reference for voltage and frequency management. SMO basically works as follows: among the converters there are bosses, others are slaves. When he thinks that the slaves have a power outage, he works in self-assertion mode, which controls the voltage reference given by the master. Many MMO converters do not have many converters that can be linked to DERs or battery and others are used as masters in QP control. A micronet can change the cycle profile by reconsidering another destination.

4.1 Control including communication

Dynamic load sharing methods are used as part of Microgrid's parallel operation converters. Inverter control depends on the communication in which different data is shared from different Microgrid generators and converters under different load conditions. Approach the Microgrid controller to concentrate (Lasseter and Paigi, 2004). The Micro Network Controller issues specific control commands to each converter device. Correspondence between the micronet controller and the converters may include the following control strategies:

- Master-slave control
- Current restrictive control
- Circular chain management (3C)
- Load Medium load sharing control

Communication lines should be used for communication-based control methods. Active loadthe sharing method reduces the reliability and scalability of the system.

- Disadvantages of communication based control

1. The communication network uses high bandwidth capacity to share between dynamic data converters. It is expensive and the distance between converters is wide in rural areas turns into an illogical operation.
2. A failure is evident because the internal controller plays a key management role.
3. The sequence of the distribution control signal decreases, that is it is important to control the data.

4.2 Control without any communication

The control of the inverter without communication depends mainly on the sliding control. The plan changes the output voltage VS reactive power (P) and frequency VS active power (P) supplied by the inverter. The output voltage and frequency of each DG converter, as well as active power and reactive power are shared. This is a technique that recognizes control (in parallel converters). In any case, this signal creates certain changes in power management. Dropping equipment does not require communication between systems, so performance increases network reliability and reduces cost. A fall strategy is currently being considered. Standard control methods in microgrids. but this is the sliding recognition of voltage errors.. (2004) proposed a change in the nature of sag control. Others have suggested improving drop-down control by enhancing active and passive separation operations by combining virtual output impedance for a specific purpose. In traditional systems, a small change in power point may be acceptable, but a microcontroller can withstand a significant power angle. Since there is no main load idea, Microgrid is subject to several loading conditions. Changes in the power demand of each inverter result in low frequency power sharing modes.

4.3 Microgrid control layer

The microgrid control system provides access to an ensemble of control tasks. The The full control operation is located on three control layers, as seen in

MicrogridThe picture below. These control levels are as follows (Vandoorn et al., 2013):

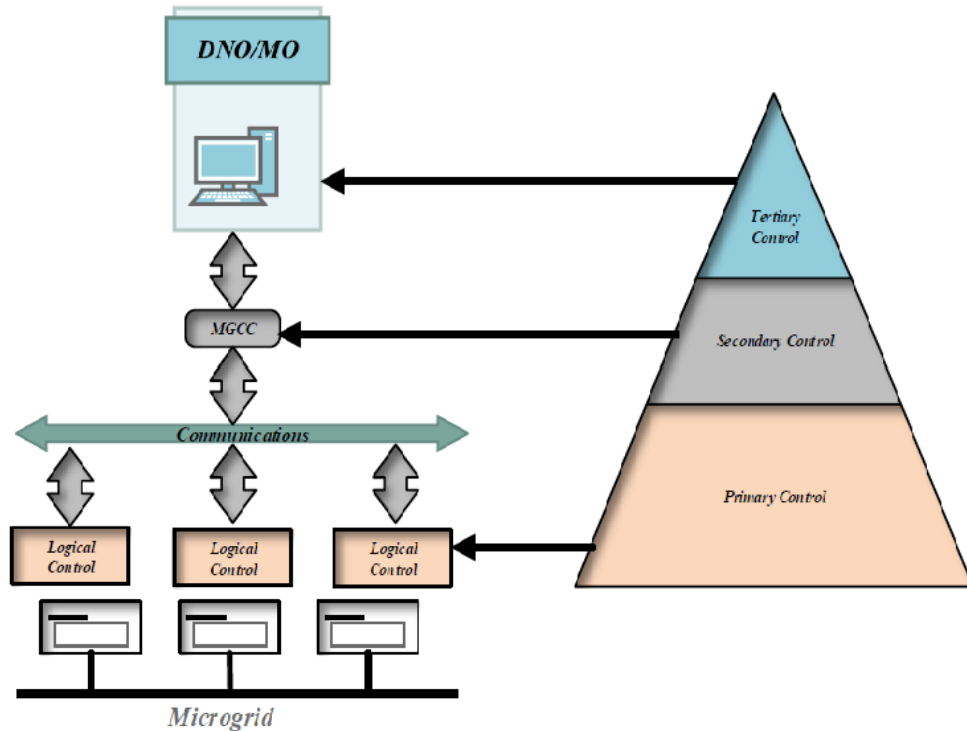

Figure 4.1: local and centralized controller for communication

Source: (Vandoorn et al., 2013).

- The second level refers to the Microgrid central control system; is the area in which it is distributed groups of energy sources are connected to the micro network. Microgrid central control is responsible for stabilizing the voltage and frequency in a certain, limited range is a common connection point. It is also responsible for active and reactive forces sent from an individual DER.
- The third level is the distribution network operator (DNO) that integrates the market operator on the main network (MO). It introduces top management and facilitates the purchase and sale of energy among consumers.

5. RESULTS AND DISCUSSIONS

The whole system model of the proposed work is shown in figure 16. The system consists of 2 renewable energy sources (RES), photovoltaic panel (PV panel), and wind energy systems. The Output voltage at the DC-DC boost converter integrated with RES is well regulated by using an MPPT controller. The MPPT controller is designed through a P&O method and implemented in both RES to get the maximum output power from these renewable energy sources (RES).

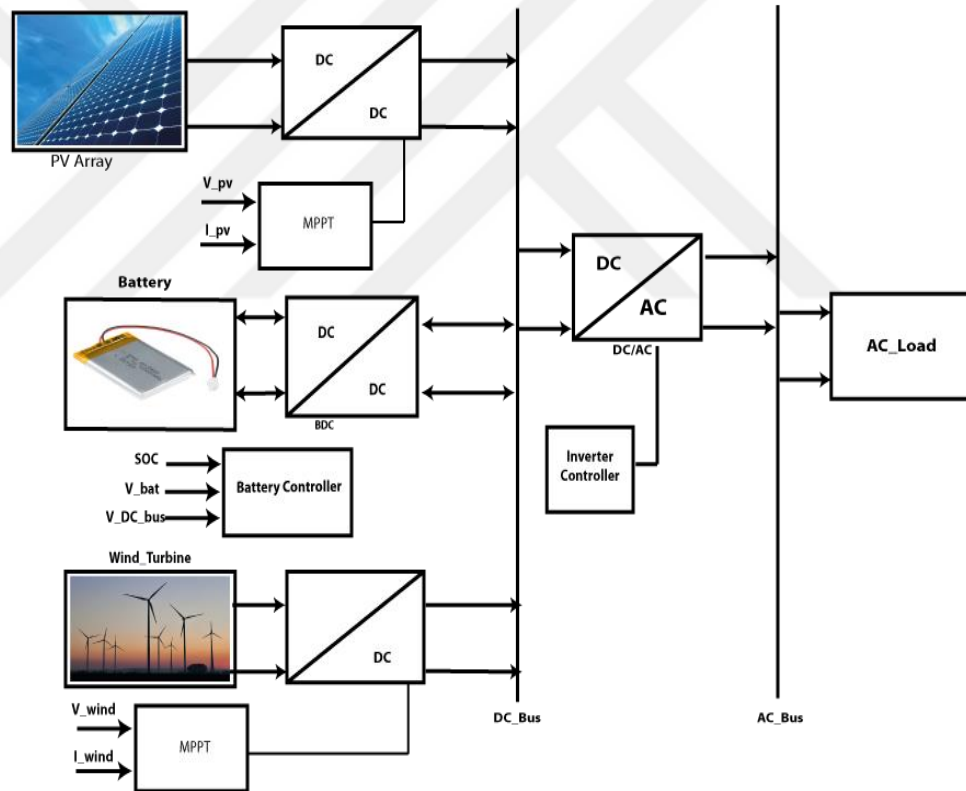

Figure 5.1: The proposed energy management system for the hybrid system

The MPPT based control for DC-DC boost converter feeding a photovoltaic energy system, is shown in figure 17.

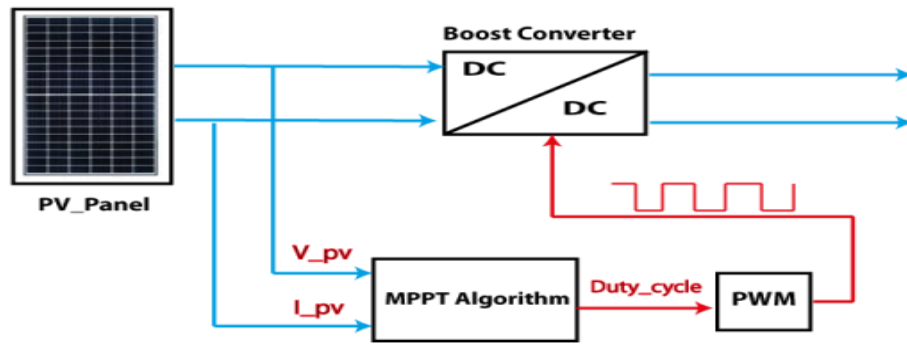

Figure 5.2: Solar conversion system with an MPPT controller

For the other renewable energy source, the wind energy again the MPPT based boost converter is implemented, as shown in figure 18.

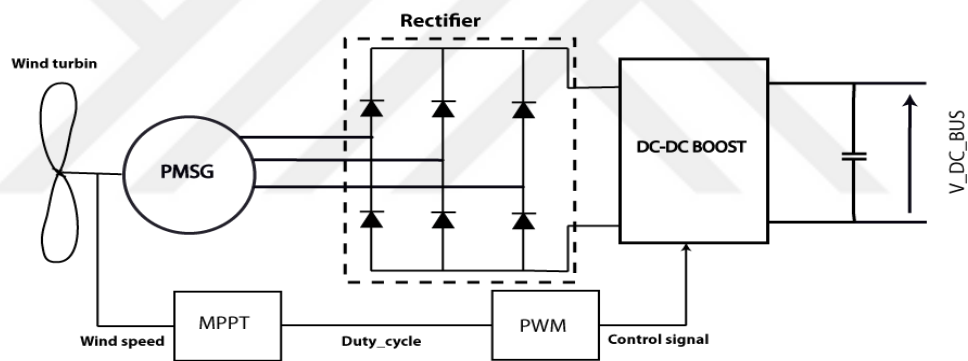

Figure 5.3: Wind system with an MPPT Controller.

An MPPT controller used in boost converter of both renewable energy sources is designed using perturb and observe (P&O) method. The algorithm for the P&O method is shown in figure 19.

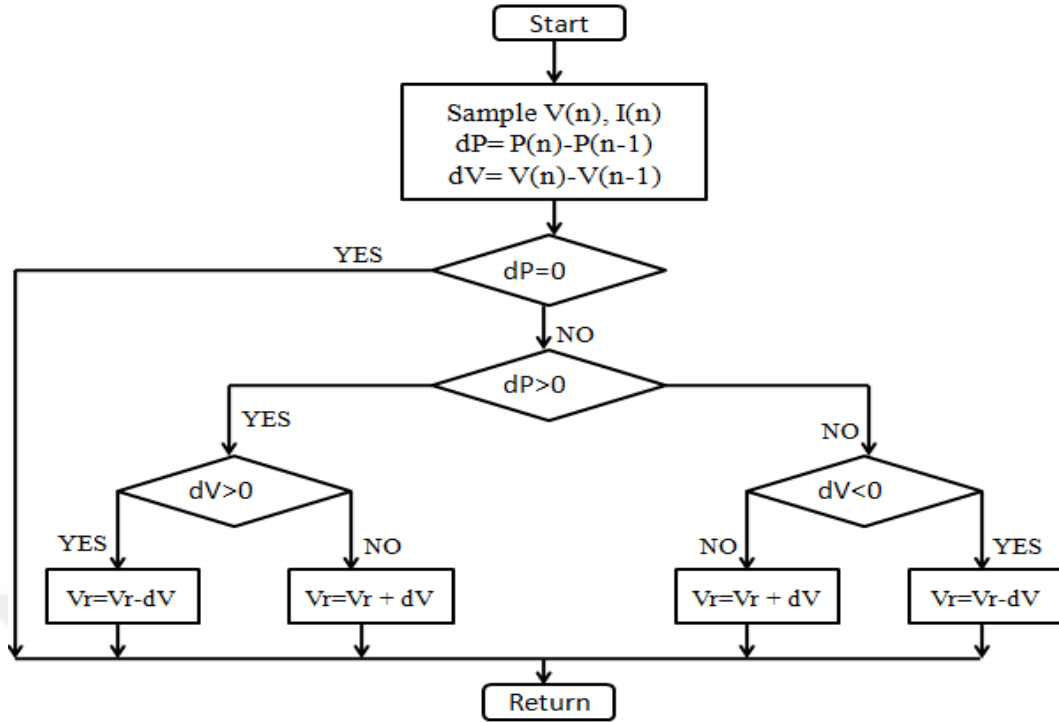

Figure 5.4: Flowchart of P&O based MPPT Algorithm

The designed parameters for small hybrid based solar-wind energies feed microgrid are shown in the table 2.

Table 5.1: Parameters for Wind-Solar and battery based small microgrid.

SYMBOL	Specification
DC_BUS	V=400v;
Battery	Type: Li-ION V=48v; Q_batt=30AH
PV PANEL	TYPE: Sunpower SPR-250 NX-BLK-D Ns: 8, Np=7
Wind turbine	P_W= 2KW,
Load	P_LAC =5KW

The renewable energy sources (RES) output power is changing and intermittent because of the changing weather conditions, so connecting a DC-DC boost converter with an MPPT controller will regulate the power at point of maximum power point. This will enhance the whole system and make it power efficient.

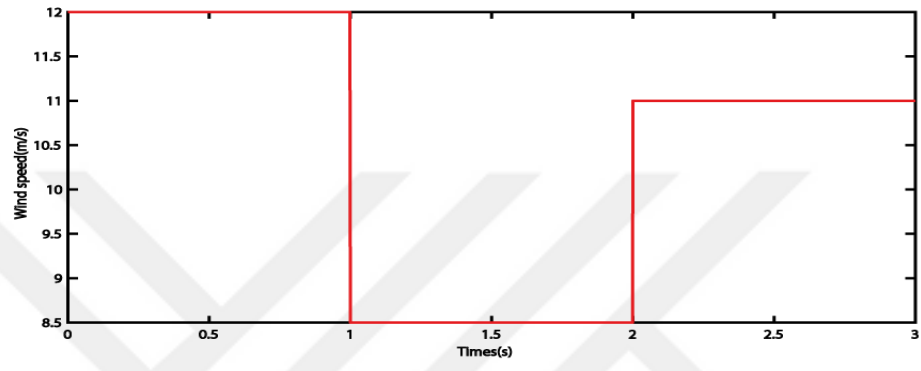
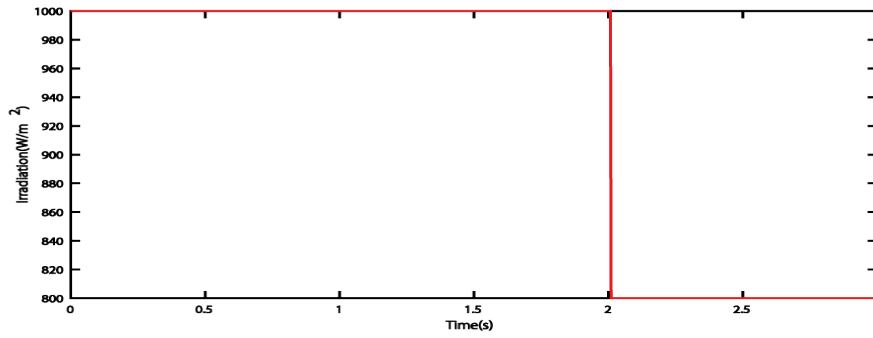

Figure 5.5: Irradiation change to represent all possible scenario

During this period the battery state of charge (SOC) changes like as shown in figure 22.

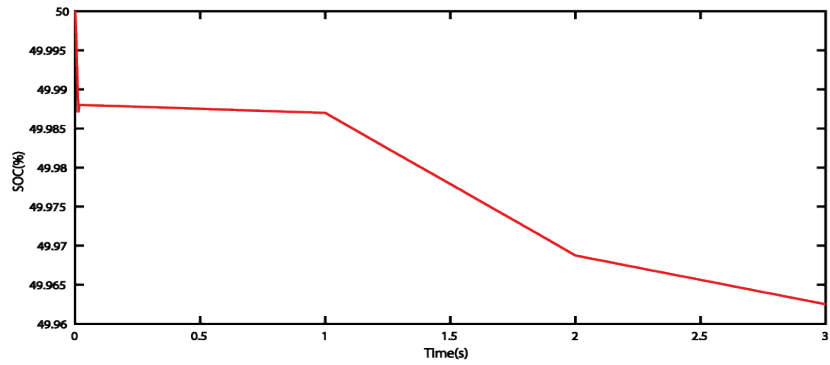

Figure 5.6: Battery state of charge (SOC).

As previously stated, the battery will be used in the event of an unbalanced system. As a result, as shown in Fig.13, the curve of the battery SoC decreases at this time, indicating that the battery provides power to the system to maintain the power balance between production and load demanded. The SoC curve decline more than the beginning because of the decreasing of the irradiation and wind speed values. Fig.14 show the variation of the bus DC voltage during the

simulation, we can see the effectiveness of the energy management strategy in the stabilization of the DC_Bus voltage.

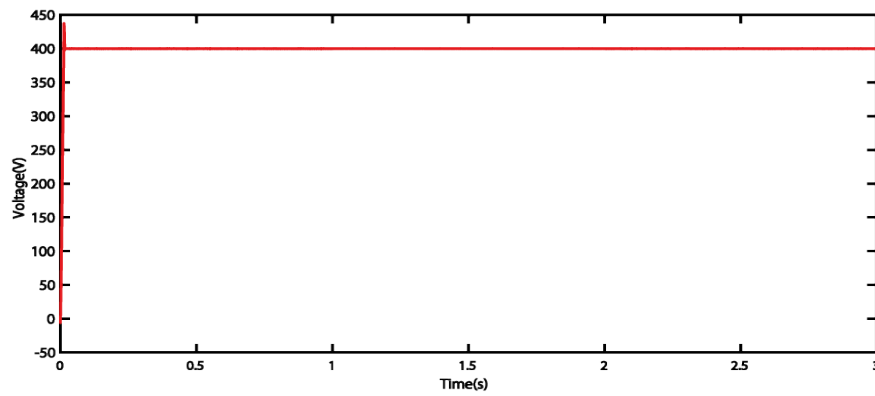

Figure 5.7: Voltage at the DC bus.

The load AC coupled to the Bus AC using DC/AC converter, Fig.15 show the voltage at the load AC during simulation.

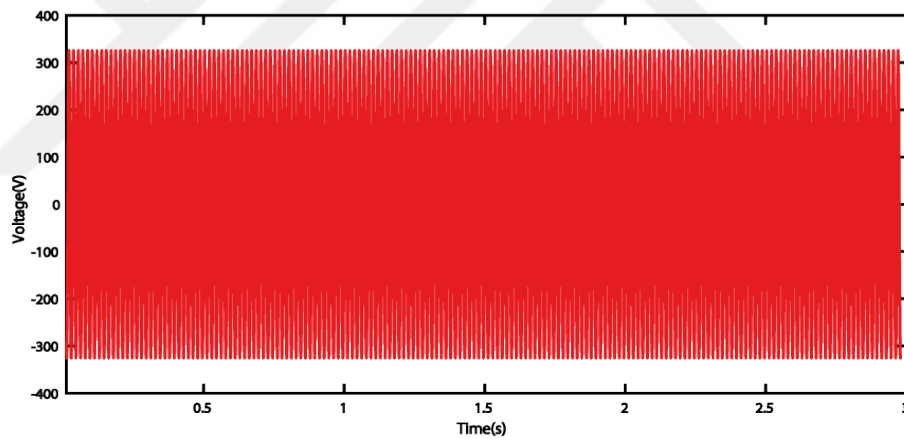

Figure 5.8: Voltage at the AC bus side

6. CONCLUSION

In this thesis work, a review of the getting solutions of the issues related to integrating renewable energy sources like solar energy and wind energy (RES) with the DC bus. Because in literature its shown that the DC bus will get unbalanced. The system consists of AC bus and DC bus with a battery storage backup. The output of PV panel is regulated by using a DC-DC boost converter based on an MPPT based controller. While the output power of the wind energy system is also well regulated by using an MPPT based controller. The both MPPT controller was designed using a perturb and observe (P&O) method.

REFERENCES:

ENCYCLOPEDIAS

https://en.wikipedia.org/wiki/Renewable_energy#/media/File:2011_Renewable_energy_capacity_-_International_Energy_Agency.svg

ARTICLES

- International Journal & magazine of engineering, technology, ‘management and research.’ a peer reviewed open access **International Journal**, Volume No. 2 (2015), Issue No. 7 (july).
- International Research Journal of Engineering and Technology (**IRJET**) Volume: 02 Issue: 04 July-2015.
- International Journal of Engineering Trends and Technology (**IJETT**) – Volume 17 Number 1 – Nov 2014.
- M. E. Baran and N. R. Mahajan**, “DC distribution for industrial systems: Opportunities and challenges,” **IEEE Trans. Ind. Appl.**, vol. 39, no. 6, pp. 1596–1601, Nov. 2003.
- Y. Ito, Z. Yang, and H. Akagi**, “DC micro-grid based distribution power generation system,” in Proc. **IEEE Int. Power Electron. Motion Control Conf.**, Aug. 2004, vol. 3, pp. 1740–1745.
- A. Sannino, G. Postiglione, and M. H. J. Bollen**, “Feasibility of a DC network for commercial facilities,” **IEEE Trans. Ind. Appl.**, vol. 39, no. 5, pp. 1409–1507, Sep. 2003.
- D. J. Hammerstrom**, “AC versus DC distribution systems-did we get it right?,” in Proc. **IEEE Power Eng. Soc. Gen. Meet.**, Jun. 2007, pp. 1–5.
- D. Salomonsson and A. Sannino**, “Low-voltage DC distribution system for commercial power systems with sensitive electronic loads,” **IEEE Trans. Power Del.**, vol. 22, no. 3, pp. 1620–1627, Jul. 2007.
- R. H. Lasseter**, “Microgrids,” in Proc. **IEEE Power Eng. Soc. Winter Meet.**, Jan. 2002, vol. 1, pp. 305–308.
- Y. Zoka, H. Sasaki, N. Yorino, K. Kawahara, and C. C. Liu**, “An interaction problem of distributed generators installed in a Microgrid,” in Proc. **IEEE Elect. Utility Deregulation, Restructuring. Power Technol.**, Apr. 2004, vol. 2, pp. 795–799.
- R. H. Lasseter and P. Paigi**, “Microgrid: A conceptual solution,” in Proc. **IEEE 35th PESC**, Jun. 2004, vol. 6, pp. 4285–4290.
- C. K. Sao and P. W. Lehn**, “Control and power management of converter fed Microgrids,” **IEEE Trans. Power Syst.**, vol. 23, no. 3, pp. 1088–1098, Aug. 2008.
- T. Logenthiran, D. Srinivasan, and D. Wong**, “Multi-agent coordination for DER in Microgrid,” in Proc. **IEEE Int. Conf. Sustainable Energy Technol.**, Nov. 2008, pp. 77–82.

- R. H. Lasseter**, “Microgrids,” in Proc. **IEEE Power Eng. Soc. Winter Meet.**, Jan. 2002, vol. 1, pp. 305–308.
- Y. Zoka, H. Sasaki, N. Yorino, K. Kawahara**, and C. C. Liu, “An interaction problem of distributed generators installed in a Microgrid,” in Proc. **IEEE Elect. Utility Deregulation, Restructuring. Power Technol.**, Apr. 2004, vol. 2, pp. 795–799.
- R. H. Lasseter and P. Paigi**, “Microgrid: A conceptual solution,” in Proc. **IEEE 35th PESC**, Jun. 2004, vol. 6, pp. 4285–4290.
- C. K. Sao and P. W. Lehn**, “Control and power management of converter fed Microgrids,” **IEEE Trans. Power Syst.**, vol. 23, no. 3, pp. 1088–1098, Aug. 2008.
- T. Logenthiran, D. Srinivasan, and D. Wong**, “Multi-agent coordination for DER in Microgrid,” in Proc. **IEEE Int. Conf. Sustainable Energy Technol.**, Nov. 2008, pp. 77–82.
- M. E. Baran and N. R. Mahajan**, “DC distribution for industrial systems: Opportunities and challenges,” **IEEE Trans. Ind. Appl.**, vol. 39, no. 6, pp. 1596–1601, Nov. 2003.
- M. E. Ropp and S. Gonzalez**, “Development of a MATLAB/simulink model of a singlephasegrid-connected photovoltaic system,” **IEEE Trans. Energy Conv.**, vol. 24, no. 1, pp. 195–202, Mar. 2009.
- K. H. Chao, C. J. Li, and S. H. Ho**, “Modeling and fault simulation of photovoltaic generation systems using circuit-based model,” in Proc. **IEEE Int. Conf. Sustainable Energy Technol.**, Nov. 2008, pp. 290–294.
- O. Tremblay, L. A. Dessaint, and A. I. Dekkiche**, “A generic battery model for the dynamic simulation of hybrid electric vehicles,” in Proc. **IEEE Veh. Power Propulsion Conf. (VPPC2007)**, pp. 284–289.
- D. W. Zhi and L. Xu**, “Direct power control of DFIG with constant switching frequency and improved transient performance,” **IEEE Trans. Energy Conv.**, vol. 22, no. 1, pp. 110–118, Mar. 2007.
- K. Kristinsson and G. A.** “Dumont. System identification and control using genetic algorithms”. **IEEE Transactions on System, Man, Cybern.** 22:1033 – 1046, Sept.-Oct 1992.
- C. H. Marrison and R. F.** “Stengel. Robust control system design using random search and genetic algorithms”. **IEEE Transactions on Automatic Control**, 42:835–839, June 1997.
- F. Cupertino, E. Mininno, D. Naso, B. Turchiano, and L. Salvatore.** “On-line genetic design of anti-windup unstructured controller for electrical drives with variable load”. **IEEE Transactions on Evolutionary Computation**, 8(4):347–363, August 2004.

ELECTRONIC SOURCES

- URL-1 A.J. Chipperfield, P.J. Flemming, A. Polheim, and C. M Fonscea. Genetic Algorithm Toolbox. University of Sheffield. Available: <http://www.ie.ncsu.edu/mirage/GAToolBox/gaot/>.
- URL-2 W. Morgantown. Fuel Cell Handbook. 6th Edition, EG&G Technical Services, Virginia, November 2002. [Online]. Available: <http://www.rwth-aachen.de/lbz/linksframe.html>.

BOOK

- J.A. Smith, M.H. Nehrir, V. Gerez, and S.R Shaw. A broad look at the workings, types, and applications of fuel cells. In Power Engineering Society Summer Meeting, volume 1, pages 70– 75, Chicago, USA, July 2002.**
- A.R Sakhare, A. Davari, and A. Feliachi. Control of stand alone solid oxide fuel cell using fuzzy logic. In Proceedings of the 35th Southeastern Symposium on System Theory, 2003., pages 473 – 476, 16-18 March, 2003.**
- M.W. Ellis, M.R. Von Spakovsky, and D.J Nelson. Fuel cell systems: efficient, flexible energy conversion for the 21st century. In Proceedings of the IEEE, volume 89, pages 1808 – 1818, Dec. 2001.**
- J. Padulles, G.W. Ault, C.A. Smith, and J.R. McDonald. Fuel cell plant dynamic modeling for power systems simulation. In Proceedings of 3dth universities power engineering conference, volume 34, pages 21–25, 1999.**
- K. Sedghisigarchi and A. Feliachi. Dynamic and transient analysis of power distribution systems with fuel cells-part i: fuel-cell dynamic model. IEEE Transactions on Energy Conversion, 19(2):423 – 428, 2004.**
- Y. Zhu and K. Tomsovic. Development of models for analyzing the load-following performance of microturbine and fuel cells. Electric Power System Research journal, Dec. 2001.**
- C. Sharma. Modeling of an island grid. IEEE Transaction on Power System, 13(3):971–978, August 1998.**
- W. G. Scott. Micro- turbine generators for distribution systems. IEEE Industry Applications Magazine, 4(4):57–62, May/June 1998.**
- H. Nikkhajoei and M.R. Iravani. Modeling and analysis of a micro-turbine generation system. In IEEE Power Engineering Society Summer Meeting, volume 1, pages 167 – 169, Chicago, USA, July 2002.**

OTHER SOURCES

- http://file.scirp.org/pdf/EPE_2015012915185063.pdf
- <http://hh.diva-portal.org/smash/get/diva2:726185/FULLTEXT01.pdf>
- <http://bryanwbuckley.com/projects/mppt.html>
- <http://myelectrical.com/notes/entryid/225/photovoltaic-pv-electrical-calculation>

RESUME

Personal Information

Name: Abrar Ahmed

Education

2019-2021 Master Of Electrical&Electronics Engineering, Istanbul Aydin University, Turkey.

2011-2016 BE (Electronics), Mehran UET Jamshoro

Nationality: Pakistan

Work Experience

2016-2018:

SITE ENGINEER – Vital International Ltd Lahore/Karachi

QUALITY CONTROL ENGINEER – TUSDEC Lahore

Language Skills

Urdu	English	Turkish
Excellent	Excellent	Good