

**T.C.**  
**ISTANBUL AYDIN UNIVERSITY**  
**INSTITUTE OF GRADUATE STUDIES**



**HYBRID MICROGRID WITH PARALLEL- AND SERIES-  
CONNECTED MICROCONVERTERS**

**MASTER'S THESIS**

**Leonard Baiye ENOW**

**Department of Electrical and Electronics Engineering**  
**Electrical and Electronics Engineering Program**

**AUGUST, 2021**



**T.C.**  
**ISTANBUL AYDIN UNIVERSITY**  
**INSTITUTE OF GRADUATE STUDIES**



**HYBRID MICROGRID WITH PARALLEL- AND SERIES-  
CONNECTED MICROCONVERTERS**

**MASTER'S THESIS**

**Leonard Baiye ENOW**

**(Y1813.300003)**

**Department of Electrical & Electronic Engineering**

**Electrical & Electronic Engineering Program**

**Thesis Advisor: Prof. Dr. Murtaza FARSADI**

**AUGUST, 2021**

**APPROVAL FORM (ONAY FORMU)**



## **DECLARATION**

I hereby declare with respect that the study “Hybrid Microgrid with Parallel- and Series- Connected Micro Converters”, which I submitted as a Master thesis, is written without any assistance in violation of scientific ethics and traditions in all the processes from the project phase to the conclusion of the thesis and that the works I have benefited are from those shown in the Bibliography. (.../.../20...)

LEONARD BAIYE ENOW

## **FOREWORD**

First and foremost, praises and thanks to God, the Almighty, for His showers of blessings throughout my research work to complete the research successfully.

I would like to express my deep and sincere gratitude to my research supervisor, Prof. Dr. MURTAZA FARSADI, Electrical and Electronic Engineering, Istanbul Aydin University, Turkey, for allowing me to do research and providing invaluable guidance throughout this research. His dynamism, vision, sincerity, and motivation have deeply inspired me. He has taught me the methodology to carry out the research and to present the research works as clearly as possible. It was a great privilege and honor to work and study under his guidance. I am extremely grateful for what he has offered me. I would also like to thank him for his friendship, empathy, and great sense of humor.

I am extremely grateful to my parents for their love, prayers, caring and sacrifices for educating and preparing me for my future. I am very much thankful to my wife and my daughters for their love, understanding, prayers, and continuing support to complete this research work. Also, I express my thanks to my sisters, brother, sister-in-law, and brother-in-law for their support and valuable prayers.

Finally, my thanks go to all the people who have supported me to complete the research work directly or indirectly.

August, 2021

LEONARD BAIYE ENOW

# HYBRID MICROGRID WITH PARALLEL- AND SERIES- CONNECTED MICROCONVERTERS

## ABSTRACT

This is about the “Hybrid Microgrid with Parallel and Series Connected micro converters”. Series connected Low Voltage micro converters are combined to build a string converter that has a rated output voltage value (magnitude). The parallel connection (operation) of each string converter to each other increases rating of and redundancy of power of the microgrid. To obtain grid-tied and islanding microgrid control having proper power-sharing, the method of hierarchical (raking) power regulation was developed having simultaneous PCC voltage and micro converters voltage control. Droop control is used to have a PCC voltage reference for power-sharing between the string converters connected in parallel. Second, a power adjusting guideline through micro converter local voltage control is utilized to rearrange yield power interest among series-connected micro converters in a string converter. As the string converter line current estimated by all micro converters is the equivalent, it is used to build up a novel synchronizer to interconnect the string converter focal regulator and the micro converter local regulators with just low transmission capacity interchanges. Because of the coordination of string converter focal control and micro converter local control, the proposed hybrid microgrid can work in network tied and islanding modes with genuine (real) and receptive (reactive) force sharing for each micro converter.

**Keywords:** *grid-tied, islanding, power-sharing, hierarchical Control, Droop control, hybrid microgrid, low bandwidth communication, decentralized control.*

# PARALEL VE SERİ BAĞLI MIKRO DÖNÜŞTÜRÜCÜLER İLE HİBRİT MIKROŞEBEKE

## ÖZET

Bu, "Paralel ve Seri Bağlı mikro dönüştürücülerle Hibrit Mikro Şebeke" hakkındadır. Seri bağlı Alçak Gerilim mikro dönüştürücüler, nominal çıkış gerilimi değerine (büyüklük) sahip bir dizi dönüştürücü oluşturmak için birleştirilir. Her bir dizi dönüştürücünün birbirine paralel bağlantısı (çalışması), mikro şebekenin gücünü ve yedek gücünü artırır. Uygun güç paylaşımına sahip şebekeye bağlı ve adalı mikro şebeke kontrolü elde etmek için, eş zamanlı PCC voltajı ve mikro dönüştürücüler voltaj kontrolüne sahip hiyerarşik (tırmıklama) güç düzenleme yöntemi geliştirilmiştir. Düşüş kontrolü, paralel bağlanmış dizi dönüştürücüler arasında güç paylaşımı için PCC voltaj referansına sahip olmak için kullanılır. İkinci olarak, bir dizi dönüştürücüsünde seri bağlı mikro dönüştürücüler arasında verim gücü ilgisini yeniden düzenlemek için mikro dönüştürücü yerel voltaj kontrolü aracılığıyla bir güç ayarlama kılavuzu kullanılır. Tüm mikro dönüştürücüler tarafından tahmin edilen dizi dönüştürücü hat akımı eşdeğer olduğundan, dizi dönüştürücü odak düzenleyicisini ve mikro dönüştürücü yerel düzenleyicileri yalnızca düşük iletim kapasitesi değişimleriyle birbirine bağlamak için yeni bir eşzamanlayıcı oluşturmak için kullanılır. Dizi dönüştürücü odak kontrolünün ve mikro dönüştürücü yerel kontrolün koordinasyonu nedeniyle, önerilen hibrit mikro şebeke, her mikro dönüştürücü için gerçek (gerçek) ve alıcı (reaktif) kuvvet paylaşımıyla ağa bağlı ve ada modlarında çalışabilir.

**Anahtar kelimeler:** *şebeke bağlantılı, ada, güç paylaşımı, hiyerarşik Kontrol, Düşüş kontrolü, hibrit mikro şebeke, düşük bant genişliği iletişimi, merkezi olmayan kontrol.*

## TABLE OF CONTENTS

<b>DECLARATION</b> .....	i
<b>FOREWORD</b> .....	ii
<b>ABSTRACT</b> .....	ii
<b>ÖZET</b> .....	iii
<b>ABBREVIATIONS</b> .....	vii
<b>LIST OF TABLES</b> .....	viii
<b>LIST OF FIGURES</b> .....	ix
<b>I. INTRODUCTION</b> .....	1
A. Problem Statement .....	2
B. Research Objectives .....	3
C. Scope of Work .....	3
D. Methodology .....	3
E. Thesis Outline .....	4
<b>II. THE CONCEPT OF MICROGRIDS.</b> .....	5
A. What is a Microgrid? .....	5
B. Types of Microgrids .....	6
1. Classifying by Purpose .....	6
2. Classifying by their Controls Approach: .....	10
3. Classifying by Type of Power Technology: .....	15
C. Microgrid Basic Components .....	18
D. How Does a Microgrid Work? .....	19
E. Microgrid Benefits and Difficulties .....	20

1. Benefits.....	20
2. Difficulty .....	21
<b>III. MICROGRID CONTROL .....</b>	<b>23</b>
A. Techniques of Basic Control: .....	23
1. Central Monitoring:.....	23
2. Control Decentralized: .....	24
3. Control Distributed:.....	24
4. Hierarchical Control:.....	24
a) Primary control [P/Q (active/reactive power) droop checking] .....	26
b) Secondary control: restore and synchronize frequency and voltage .....	29
c) Tertiary control (P=Q importation and exportation):.....	30
<b>IV. MODE OF MICROGRID OPERATION .....</b>	<b>32</b>
A. Mode of Operation Connected to the Grid.....	32
B. Insular (Islanded) Operating Mode .....	32
C. Progression Between Grid-Connected and Islanded Mode .....	34
<b>V. MICROGRID OPERATIONS AND MAINTENANCE. ....</b>	<b>35</b>
A. Maintain Stability and Synchronous Operation of the Microgrid System.....	35
B. Inaccuracies.....	36
C. Costs of Operation.....	36
D. Maintenance .....	37
<b>VI. MICROGRID PROTECTION .....</b>	<b>39</b>
A. Protection Schemes of Microgrid.....	39
B. Impedance-Based Protection Method:.....	40
C. Adaptive Protection: .....	42
D. Voltage-Based Scheme:.....	42
1. Transformation Method.....	42

2. Harmonic Method.....	43
E. Distance Protection .....	43
F. Harmonic Current.....	44
<b>VII. HYBRID MICROGRID WITH PARALLEL- AND SERIES-CONNECTED MICRO CONVERTERS .....</b>	<b>45</b>
A. My Hybrid Microgrid Proposal.....	45
1. Control of DG Unit Power .....	45
2. Microconverter Local Power Control.....	48
3. Coordination of String Converters and Microconverters .....	50
<b>VIII. PROPOSED MICROGRID SIMULATION.....</b>	<b>54</b>
A. Grid-Tied Operation Simulation .....	54
B. Islanding Operation Simulation.....	65
<b>IX. CONCLUSION.....</b>	<b>72</b>
<b>X. REFERENCES.....</b>	<b>73</b>
<b>APPENDIX.....</b>	<b>79</b>
<b>CURRICULUM VITAE.....</b>	<b>81</b>

## ABBREVIATIONS

<b>AC</b>	: Alternating Current
<b>CAN</b>	: Circulation Network Administrator
<b>DC</b>	: Direct Current
<b>DERs</b>	: Distributed Energy Resources
<b>DG</b>	: Distributed Generation
<b>DSM</b>	: Demand-Side Management
<b>IBS</b>	: Intelligent Bypass Switch
<b>LA</b>	: Local Area
<b>LCs</b>	: Local Controllers (Regulators)
<b>LCOE</b>	: Levelized Cost of Electricity
<b>LV</b>	: Low Voltage
<b>MCC</b>	: Microgrid Central Controller
<b>MCR</b>	: Microgrid Central Regulator
<b>MPPTs</b>	: Maximum Power Point Tracker
<b>NG</b>	: Natural Gas
<b>O&amp;M</b>	: Operation & Maintenance
<b>PCC</b>	: Point of Common Coupling
<b>SES</b>	: Static Exchange Switch
<b>UPSs</b>	: Uninterruptible Power Supply

## LIST OF TABLES

Table 1: Parameters of the Simulated & Experimental System ..... 53



## LIST OF FIGURES

Figure1: Typical Microgrid Layout.....	6
Figure2: Layout of a Typical Campus.....	7
Figure3: Overview of Operations of a Typical Community/Utility microgrid.....	8
Figure4: Commercial or Industrial Microgrid .....	9
Figure5: Centralized System Schematics .....	11
Figure6: Schematic of a Decentralized Control System.....	13
Figure7: Advantages of Centralized over Decentralized Microgrids.....	14
Figure8: Advantages of Decentralized over Centralized Microgrids.....	15
Figure9: Schematic of an Alternating Current Microgrid Bus with Solar and Wind Generation .....	16
Figure10: Schematic Diagram of a Direct Current Microgrid using Solar, Wind and Micro Gas Turbines.....	17
Figure11: Typical Block Diagram of a Hybrid Alternating Current/Direct Current Microgrid.....	18
Figure12: Illustration of Hierarchical Control at Different Stages. ....	25
Figure13: P–X and Q–E Grid Scheme using P* and Q* as Set Points.....	27
Figure14: Droop Control using P/Q .....	28
Figure16: Droop Feature for Capacitive or Inductive Load Supplies.....	29
Figure17: Control Primary and Secondary Based on a Plan for Hierarchical Management .....	30
Figure18: Tertiary Control Block Diagram with Control Loop Synchronization...	31
Figure19: Flexible Microgrid and IBS Grid Status Monitoring Operating Modes and Transitions.....	34
Figure20: Traditional Coordination of Protective Relays .....	40

Figure21: The Zones of Distance Protective Relays.....	41
Figure22: Impedance-Based Protection Scheme.....	41
Figure24: A String Converter System's Equivalent Circuit.....	47
Figure25: Phasor Diagram of a Microconverter. ....	47
Figure26: Central Controller of Hybrid Microgrid .....	51
Figure27: Local Controller of the Hybrid Microgrid.....	52
Figure29: Grid-tied Simulink Model.....	55
Figure30: Power Control Study of String Converters (Grid-Tied). ....	55
Figure31: Microconverters Real (Active) Power Control Performance (Grid-Tied). .....	56
Figure32: Microconverters Reactive Power Control Performance (Grid-Tied). ....	57
Figure33: PCC Voltage and String Converter Line Current during the Transition of Local Power Regulation. (Grid-Tied) .....	58
Figure34: Microconverter Voltage Before and After Local Power Control. (Grid- Tied) .....	59
Figure35: String Converter Dynamic Performance. (Grid-Tied).....	60
Figure36: Microconverter1 Dynamic Performance. (Grid-Tied; DC-link Connected to Supercapacitor) .....	61
Figure37: Microconverter2 Dynamic Performance. (Grid-Tied; DC-link Connected to Supercapacitor) .....	62
Figure38: Microconverter3 Dynamic Performance. (Grid-Tied; DC-link Connected to Supercapacitor) .....	63
Figure39: Microconverter4 Dynamic Performance. (Grid-Tied; DC-link Connected to Supercapacitor) .....	64
Figure40: Two-String Converters Real Power-Sharing Performance (Islanding)..	66
Figure41: Islanding Simulink Model of Hybrid Microgrid. ....	66
Figure42: Two-String Converters Reactive Power Sharing Performance (Islanding). .....	67

Figure43: Two String Converters Line Current and PCC Voltage Magnitude (Islanding).....	68
Figure44: Microconverters Reactive Power Control Performance (String Converter1; Islanding).....	69
Figure45: Microconverters Real Power Control Performance (String Converter1; Islanding).....	69
Figure46: Microconverters Real Power Ratio (String Converter1; Islanding). .....	70
Figure47: Microconverters Reactive Power Ratio (String converter1; Islanding). 70	
Figure48: Microconverters Voltage Waveforms in Various Situations (String Converter1; Islanding).....	71



## I. INTRODUCTION

Since the first-time electrical energy could be harnessed, its generation and distribution have come with struggles that have brought about new systems always. As the world population grows, the cities and metropolises keep getting bigger as the years go by; the installation of distributed generation units keeps growing and brings about Subsequent improvements to modern sophisticated power unit distribution electrical systems. When many identical DG units operate together, they can create a microgrid to provide the piles within the power circulation system with a more flexible supply of power. Similarly, the method might reduce confidence in the structure and create poor performance during transient loads (HE, et al., June 2018). The well-known DG control approach for the activity of distributed synchronous generators has been applied for the control of aligned DG units to avoid the need of high transmission capacity exchanges. In any event, the usual drop control may mismatch strength and (reactive) receptive power, especially if the micro-grid network has imbalanced/symphonic loads or the feeder is largely resistant. Many modified approaches were developed to increase the display of drop control. For example, the virtual genuine (real) and responsive (reactive) force and the virtual recurrence (frequency) and voltage extent ideas have been proposed to decouple the genuine and receptive power sharing control. To keep a steady activity of feeble microgrids and to improve the receptive force sharing control precision, the virtual impedance-based control strategy was proposed. The gradual control of a microgrid or microgrid bunch was implemented at a later date. Using the aid of this control calculation, the recurring AC network, PCC voltage and DC rail voltage variations can, by combining an optional control or dispersing auxiliary control, be fully remunerated in a coherent state. Note that the battery/supercapacitor frame may be incorporated into the DC connections of the hang-controlled DG unit to compensate the discrepancy between the power interest and the accessible power from environmentally friendly backstage power.

## A. Problem Statement

As staggered converter methods are progressing, a DG unit often contains small LV converter modules with various fuel sources. The most important interface converter rivals are the Cascaded H-Connect (CHB) or Modular Multi-Level Converter (MMC) designs. In all cases, the previous study focuses largely on the output power and current response of the interface converter. The inner power demand part between LV cells can hardly be achieved under the present scenario. A number of updated ways to regulate the inland power section of the network have been suggested for addressing this issue. Every H-connected cell's autonomous Maximum Power Point (MPPT) Tracking or ideal reaction force support is to be the authentic and receptive power reference. Also, to single-stage applications, the power quality concerns of this design in a three-stage framework, for example, the between stage awkwardness current remuneration.

Lately, a DG interface converter is being developed using the series-connected LV micro converters with an LC channel for every cell. These new landscapes have been verified to provide more flexibility and reduce network conversion costs. In principle, because of the usage of simply LV DC rails the high voltage DC cable is not necessary. The highly installed DC/DC support converter is removed from the framework for the common DG unit. A few other topics have to be considered in order to encourage the use of series micro converters DG-network interface converters into a double-mode microgrid: 1) Given the restriction of accessibility to environmentally friendly power assets, micro converters that are remotely introduced are often linked as a string converter network in series. In this case, the unchanging quality of the network may be dwindled by considerable distances with high transmission rates between micro converters and micro grid main control. 2) Previous tests focused mostly on matrix-linked activities. The voltage-retaining compartment for islanding microgrid should be developed for double mode microgrid applications. 3) The force splitting between the arrangement related LV converters cannot be managed by conventional hanging control approaches (HE, et al., June 2018). In order to resolve this limit, the Droop control reverse power factor was used to maintain the power split in the islanded architecture amongst linked converters. Sadly, with other DG units operated by classical droop control, the yield attributes of that DG unit are not feasible. Therefore, it is certainly necessary to establish a summarized energy management

strategy that can grasp valid power sharing at both the level of the DG string converter and the cable level of the micro converter.

## **B. Research Objectives**

Convinced by the foregoing dialogues, micro converters in series and parallel are used to frame an activity microgrid with framing capacities and isolation capacities. At first, a few series are used to shape a string converter coupled with the micro converters. The parallel association of string converters is used to provide the microgrid with capacity. This suggested framework uses a progressive power-sharing scheme, where the ranking control conspires, and the lower-level control, is responsible for the circulation of power across series-associated micro conversions. The suggested framework uses the power-sharing schemes. The framework can be more adaptive by means of this control calculation since every microconverter may share power in both grinding and isolating modes. The main portion of the string converter line current is used as synchronizer to form a new sync system between the string transformer focal control frame and the micro converter neighbourhood monitoring framework to lower the weight of correspondences for progressive control. The correctness of the suggested framework is checked by re-enacted and test outcomes.

## **C. Scope of Work**

In this research work the main focus is to improve the outputs (Electric Power) and stabilises outputs of Hybrid Microgrids and also to facilitate the control and transmission of electricity.

## **D. Methodology**

The Research started with studying the previous works in this field. Microgrids are main part of electrical distribution systems. Droop Control and Sliding Discrete Fourier Transform were used in the both Local and Central Controls. Microconverters are utilised which were made up of H-bridges, DC voltages, Supercapacitors, and Inductors.

## **E. Thesis Outline**

The thesis structure consists of the chapters that are given below:

Chapter 1: An introduction into the thesis work.

Chapter 2: The literature review of microgrids is given in this chapter.

Chapter 3: In this chapter, method in which the thesis carried out given, simulation with MATLAB-Simulink and circuit are explained briefly.

Chapter 4: Results, discussions and conclusion are given in this chapter.



## **II. THE CONCEPT OF MICROGRIDS.**

### **A. What is a Microgrid?**

A microgrid is a decentralized assembly of Electric Sources and loads that function regularly in relation to a conventional large area organization (full-scale network) and may also detach from the "insular mode" and autonomously limit them as natural or economic conditions (Energy, 2014). The ideal solution is to seal up microgrids by sources of fuel when electricity transmission and dispersal from a large unified fuel is extremely long and expensive to carry out. The microgrid is called an independent, free or unconnected microgrid in addition to the existing circumstances.

A microgrid is defined as a social event of interconnected loads and dispersed electric resources (DERs) inside clearly illustrated power restrictions that likely go on as a single controlled substance about the network by the US Department of Energy Microgrid Exchange. A microgrid can be connected and separated from the structure to function in the related or insular way (Energy, 2014).

The European Union's research project describes a microgrid, encompassing the low-voltage (LV) dispersion structures with enough energy resources (microturbines, electricity modules, PV systems), storage energy (batteries, flywheels), and multiple weights (Energy, 2014). Such systems can be connected or removed from the main grid. The migration of down-scale sources can give advantages for the overall implementation of the system at every point that is handled and dealt with capable.

As a result, microgrids increase supply security inside the microgrid cell and may deliver electricity by switching between the island and the corresponding modes. They also allow a nation the chance to pay for remote areas and geographical islands in more discretion. A microgrid may properly organize several sources of distributed power (DG) into controlled components, especially renewable energy sources (RES).

Control and protection are microgrid inconveniences, as the precise action of assertive organizations may be taken by all subordinate system change organizations inside the microgrid and at small short output levels. A crucial component is equally

important, as this allows energy carriers to substitute and expand energy profits as a consequence of waste warmth, local high temp water and cooling purposes, in the meantime, warmth, cooling and strength. for example (cross-sectoral energy use).

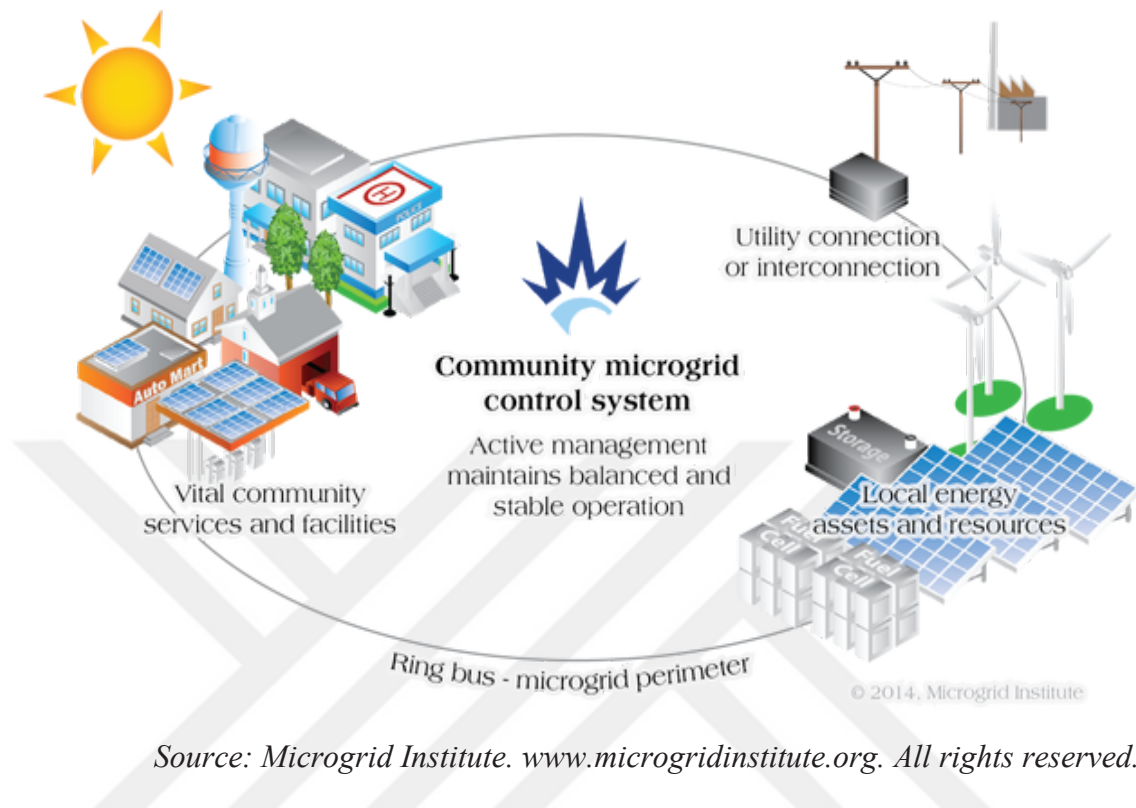

Source: Microgrid Institute. [www.microgridinstitute.org](http://www.microgridinstitute.org). All rights reserved.

Figure1: Typical Microgrid Layout

## B. Types of Microgrids

Microgrids are characterized from multiple points of view (through their motivations, their controls approach, kind of Power innovation). There are a couple of sorts of microgrids for different applications. As business areas, advancement, and rule changes, such microgrids will continue creating.

### 1. Classifying by Purpose

#### a. Campus environment or institutionnal microgrids

Could insinuate corporate grounds, school grounds, and military grounds. Often, they are CHP (Combined Heat and Power). The point of convergence of institutional microgrids is gathering existing close by age to help different weights arranged in a close geographical position district Where can a client without a very remarkable stretch administer them (ASIAN DEVELOPMENT BANK, JULY 2020.).

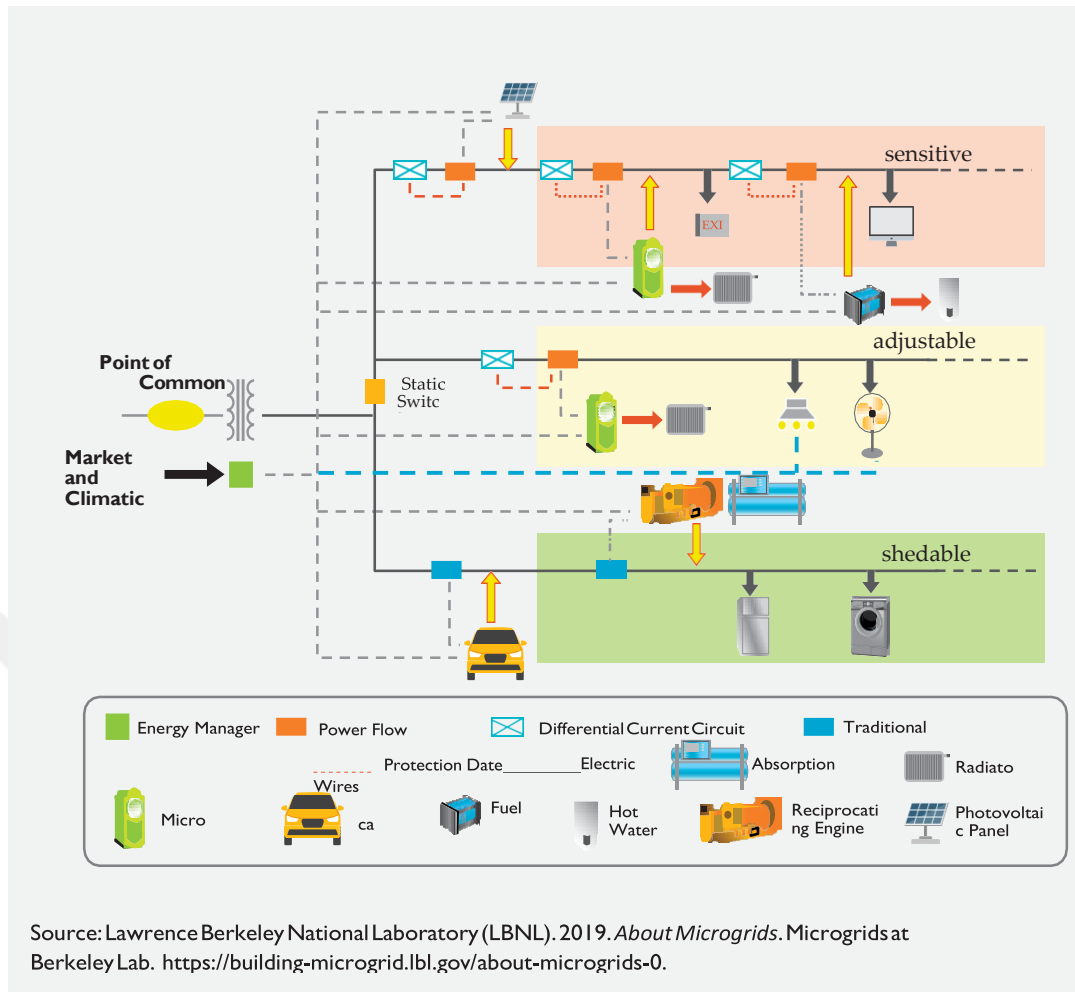

Figure2: Layout of a Typical Campus Microgrid

### b. Military based microgrids

For the United States DOD's key aim is to reliably integrate sun-driven PV with accumulated energy into military energy architecture. Depending on diesel fuel in remote zones in the globe is a weak spot in military exercises, and the test results for transportation fuel to antagonistic locations may be dramatic and lethal. Similarly, the DOD considers ecological change to be an incentive to increase shakiness by reducing surges both within and outside.

### c. Communities microgrids

Can be considered as daylight-based 2.0 organization. Network microgrids can also be utilized to load from the blue in a causative circumstance. They're in the main world consistently for helping networks with achieving economical force targets. Local area microgrids can serve an immense number of customers and sponsorship the passageway of close by energy (force, warming, and cooling). In an organization

microgrid, a couple of Houses could have a few limitless sources that are able to provide advantage similarly like their neighbours inside a comparative organization. The social class microgrid may in like manner have a consolidated or a couple of passed on energy reserves. Such microgrids can be as a climate control system and dc microgrid connected via a two-way electronic converter power.

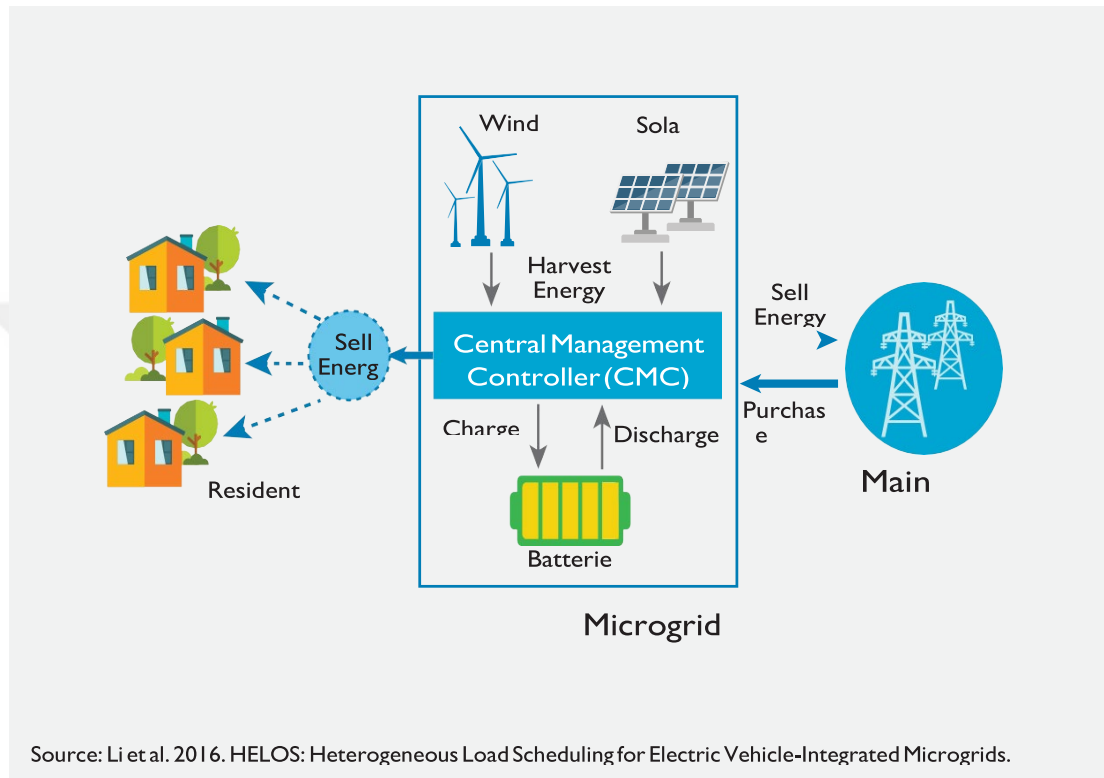
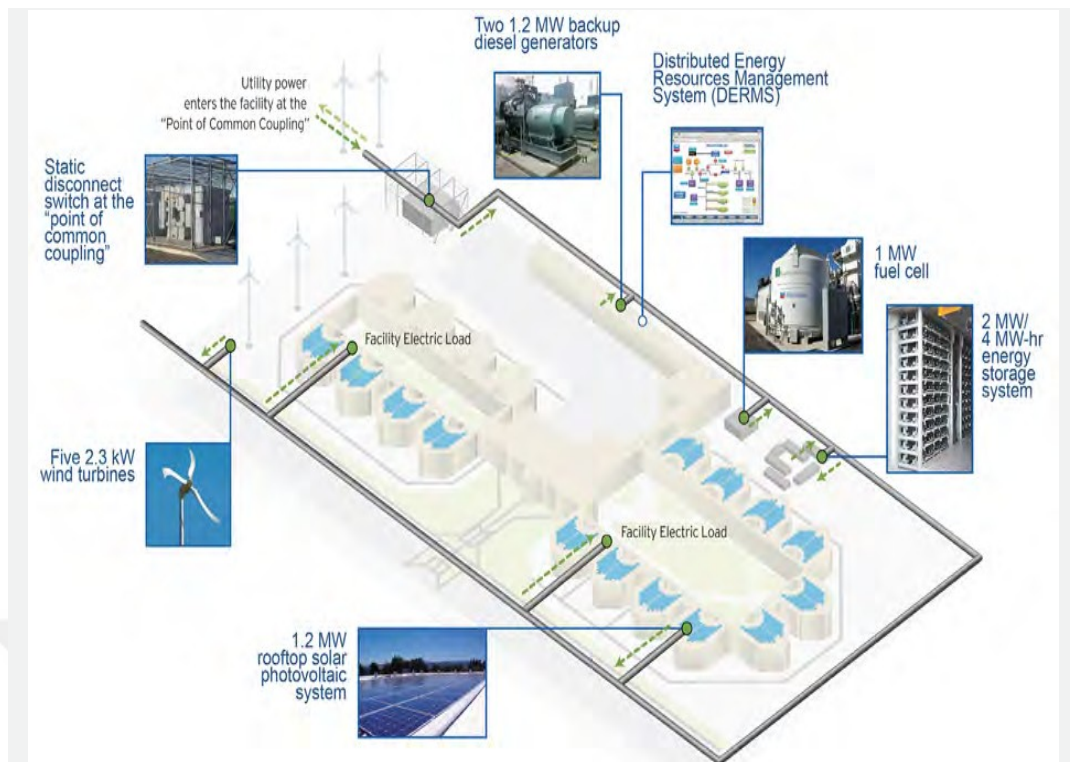

Figure3: Overview of Operations of a Typical Community/Utility microgrid

#### d. Trade and industrial microgrids

In North America and eastern Asia this kind of micro grids increase swiftly, yet in every event they are confined worldwide by the lack of exceptional criteria for these tiny grids. Strom supply security and their trustworthiness are the main objectives underlying a modern microgrid. Increased impacts can create large league wage backs and a longer start-up period. There are several collection measures in order to offer indirect (near) zero-swelling current cycles, industrial microgrids may be developed and can cause consolidated warmth and the generation of force to be handled by both unbounded sources and wastes; energy gathering may also be employed to smooth out the tasks of these undertakings (ASIAN DEVELOPMENT BANK, JULY 2020.).



kW = kilowatt, MW = megawatt, PG&E = Pacific Gas and Electric.

Source: Scott, N. 2016. *Microgrids: A Guide to their Issues and Value. Highlands and Islands Enterprise in PaGovernment of Scotland.* <https://www.hie.co.uk/media/5957/a-guide-to-microgrids.pdf>.

Figure4: Commercial or Industrial Microgrid

#### e. Remote and off-grid microgrids

This sorts of microgrids are normally treated independently. These microgrids never interface with the enormous scope organization (full scale framework) and rather work Reliably in the island mode due to the problems of money or the standing of the country. Usually, a "off-lattice" microgrid is specific fields that are remote from being transmitted and disseminated and hence not related to the utility organisation. Studies have revealed that the operating of off-structure microgrids in a remote district or islands dominated by unlimited sources reduces the cost of creating force over such microgrid projects.

A couple of independent microgrids, each with another owner can be provided colossal unreachable zones (executive). But for the most part such microgrids are suggested to be energy self-sustaining, unpredictable and unlimited sources and the terrifying and acute ranges might lead to unforeseen power failure or excessive aging. This causes unacceptable voltage or a repeat variation in the microgrids quickly. To set such circumstances, such microgrids can be momentarily connected to a proper

adjacent microgrid for swap control and voltage improvement and repeat deviations. This can be refined by a power-contraction-based switch following an adaptive synchronization or a continuous relationship between two power electronic converters and following the certification of the safety of the new structure. By upgrading or dynamic techniques, the necessity to link adjacent microgrids and to track the appropriate microgrid to couples may be confirmed.

#### **f. Blockchain microgrids**

Blockchain Microgrids allow forwards without the commitment of electricity to purchase and sell power, and it is transformed into reality by and by. This all-round type of microgrid is now transmitted in New York, Africa, Europe and Australia and electricity providers strive to identify progress that they perceive as a danger.

#### **g. Desalination Microgrids**

Revelment For the management of water problems using renewable sources, microgrids are pursued. Without energy store, daylight-based desalination may be developed essentially by desalting and taking care of water during sunlight.

#### **h. Autonomous EV microgrids**

EV automatic control Driverless electric cars allow microgrids, which can obtain the electricity when there is no trace on a residential system or microgrid. Similarly, it may get messages from farms indicating they transport excessive energy and can almost never end.

#### **i. DC microgrids**

A downpour of the DC microgrids, as sun-locked sheets, electric cars, batteries, LED lights and DC contraptions overwhelm the electricity network, might inevitably lead the pioneers to look to more attractive technologies to hang them.

### **2. Classifying by their Controls Approach:**

One technique to manage microgrids is dependent on their *centralized or decentralized* operational control.

A single substance is in danger, in a fused microgrid system, of picking the setpoints, distributed age assets and the limit unit, for the unique cycles of the

micronutrient central control unit (MCR). The MCR speaks about weight relationships, power distribution systems DERs (Displayed Energy Resources) and circuit breakers (DERs) and microgrids with the rest of the system to manage the dynamic and responsive power commitment of the converters. Regularly for data transfer distant communication propels are employed. This architecture is a good choice when all microgrid performers have common goals. The united control is accomplished in the traditional electrical grid by a single component on an executive level of the transmission system. Moreover, a single component completes the currency shipment and the unit duty valuations in accordance with a microgrid. A MCR gives the right settings to the sources (as would have been by the flow structure head in the standard electric cross section). The dispersal system director or a microgrid chairman, which is presented, can administer an MCR depending upon the arrangement of ownership.

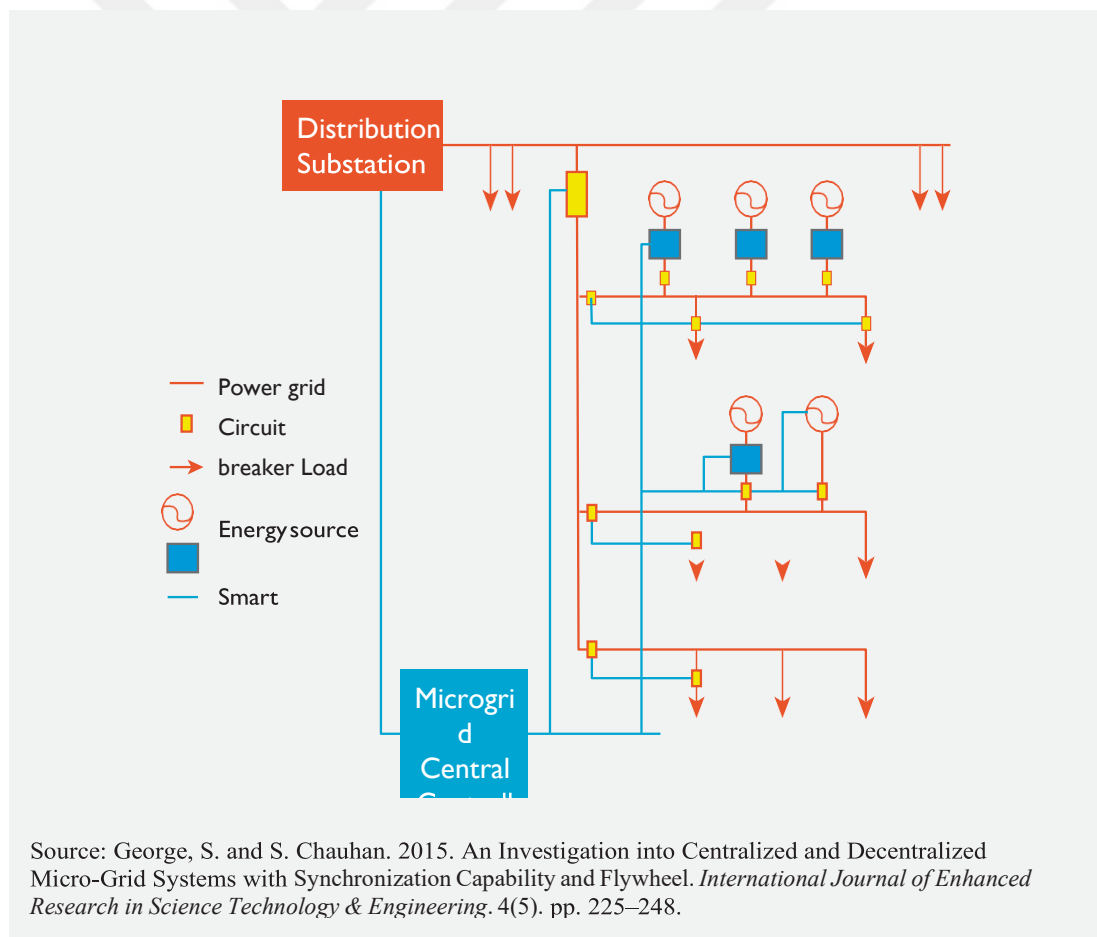

Figure5: Centralized System Schematics

The inward microgrid control is carried out on each controllable part of the microgrid – generators, storages and stacks – inside a decentralized microgrid

architecture. It needn't bother with a stunning central controller and is impenetrable to a singular reason for dissatisfaction. A plan among the different performers may happen, especially considering the way that for the present circumstance, the different performers have different destinations, yet customary perspectives and calculations, like stack deciding, state evaluation, and security checking ought to, regardless, be conceivable in a consolidated way. The introduction of the control estimations depends upon four key credits:

- The number of jacks. The DG and the controlled burden of the microgrid impact the diverse character and the number time.
- Number of exchanged messages. In microgrids, the DG and loads are usually distributed and low voltage match structures often have a limited transmission speed. The number of messages required to perform a transcript in a few circumstances is crucial. A decentralized monitoring strategy reduces the amount of communication, because only a small part of the data needs be sent to higher levels.
- The frame model's size and construction. It is necessary to consider the structure and complex character of the structure. Choices taken through various entertainers may build the quantity of hubs as well as force additional specialized and non-specialized limitations.
- The exactness and optimality of the arrangement. The assembly and precision of the arrangements rely upon the sort and exactness of the calculations utilized and the information.

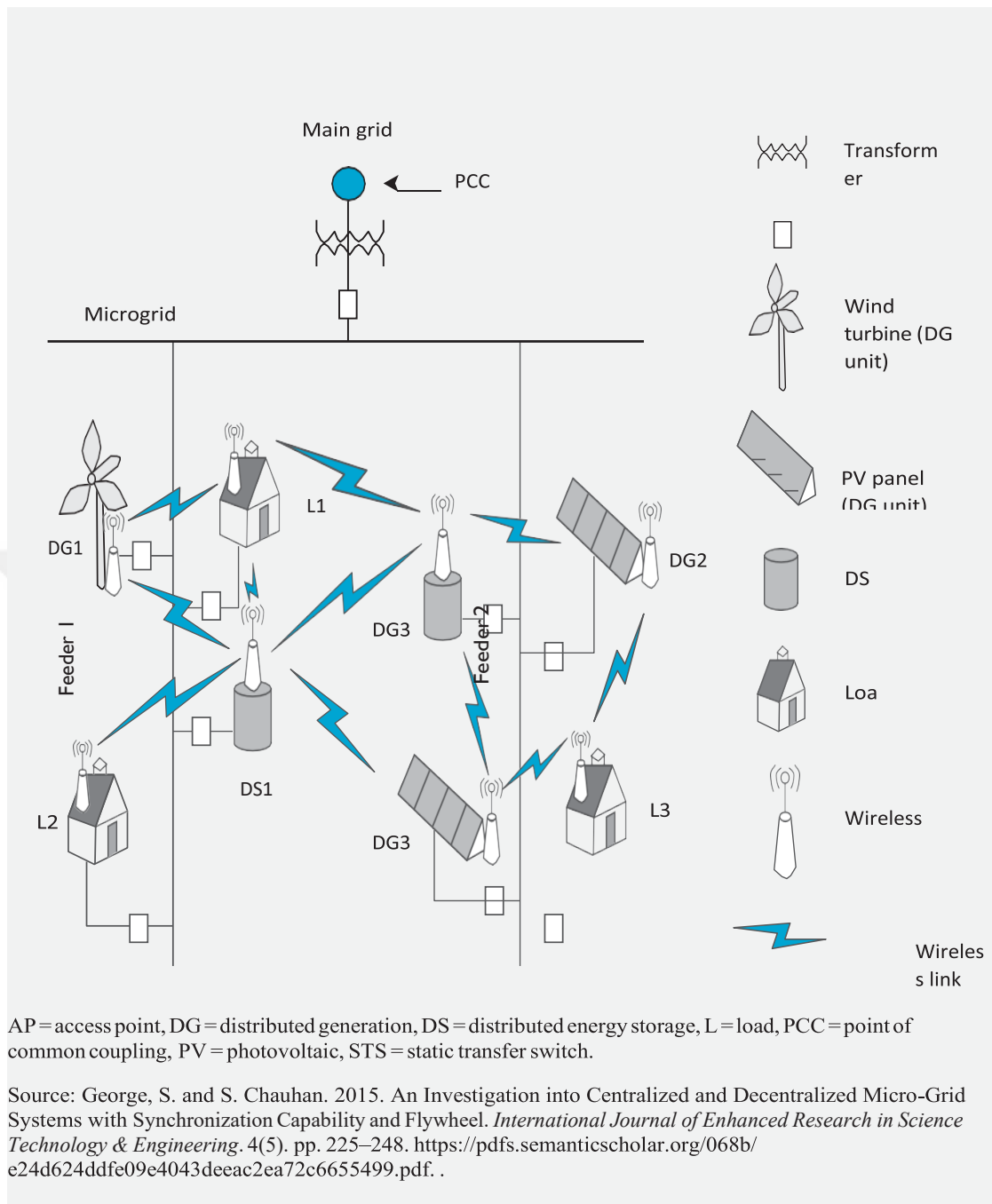

Figure6: Schematic of a Decentralized Control System

**a. Centralized benefits over decentralized advantages**

**i. The following benefits apply to centralized control systems:**

- They have high activity data, which clearly acknowledge and achieve the main objectives.
- You can organize widely, ideally.
- They allow for the basic grid to be synchronized simply and allow continuous indicators to be used for online activities.

- Decentralized control plans have the principal impediment of being exceptionally intricate as for multi possession and rivalry between the different entertainers or specialists. Every specialist tries to accomplish its own even-handed, for example, expanding its benefits.

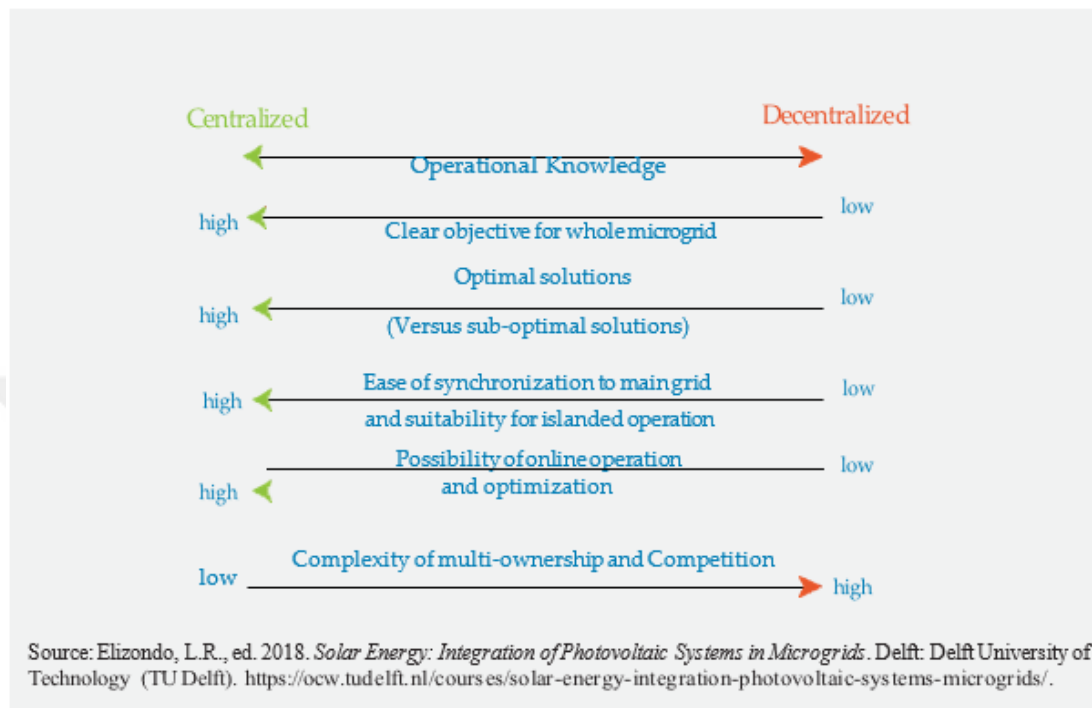

Figure7: Advantages of Centralized over Decentralized Microgrids

## b. Decentralized benefits vs centralized benefits

### i. Decentralized control strategies are of major interest:

- They are appropriate for quick evolving foundations. They could undoubtedly be extended on account of their plug-and-play abilities.
- They are dependable.

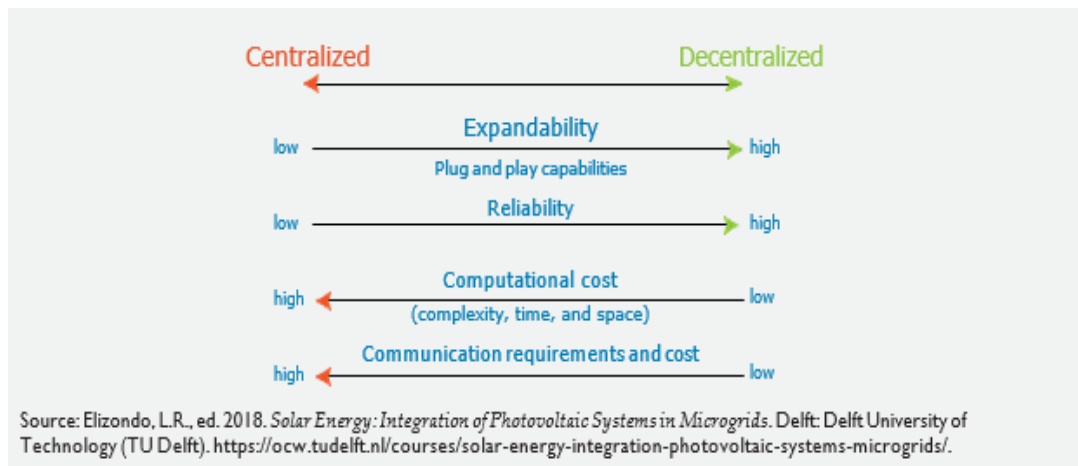

Figure8: Advantages of Decentralized over Centralized Microgrids

### 3. Classifying by Type of Power Technology:

In addition, microgrids may be structured according to the kind of advanced power dispersion employed, AC, DC or half race. Whilst a few ideas are in order to ensure a growth of strength for the microgrid, an AC microgrid will likely be the most suited selection because the present foundations are not changing significantly. In any case DC or crossover microgrids have consistently improved performance and should be taken into account for future microgrids. As for AC micro grid propulsion from current foundations, it is probably more vital to determine if the two ways or crossover arrangements are combined to compromise the close-by-power age and the use both of online and of off-network applications.

#### a) AC microgrid

All DER (feasible and non-exhaustible), energy accumulators, and end-user load (both AC and DC) in an AC microgrid are associated with the usual transmission of ACs (spine association). Just when the energy age of the microgrid exceeds each battery, a bidirectional AC/DC converter enables the microgrid (exchanging) energy to be transferred via the utility grid and to chargers their energy accumulation equipment, for example batteries. On the other side, the microgrid storage may either accept energy from the power supply system or from its own charged fuel amassing sources when they are over its internal age. This is the (customary) cross-sectional action strategy. In all events, if the problem happens on the power grid and piling requirements are not satisfied, the microgrid retires from the PCC utilities and starts working in isolated mode. The benefits of the AC microgrids include their versatility

to simplify composition with the main AC power structure and the simplicity of changing voltage. Furthermore, the cost of the AC microgrid equipment was lower than that of the DC microgrids. For the two metropolitan networks and nation domains, AC Microgrids are a feasible solution. When disruptive impacts or failures occur, the powerful force can be produced separately. So, the quantity of AC microgrids is significantly superior than those of DC microgrids starting now.

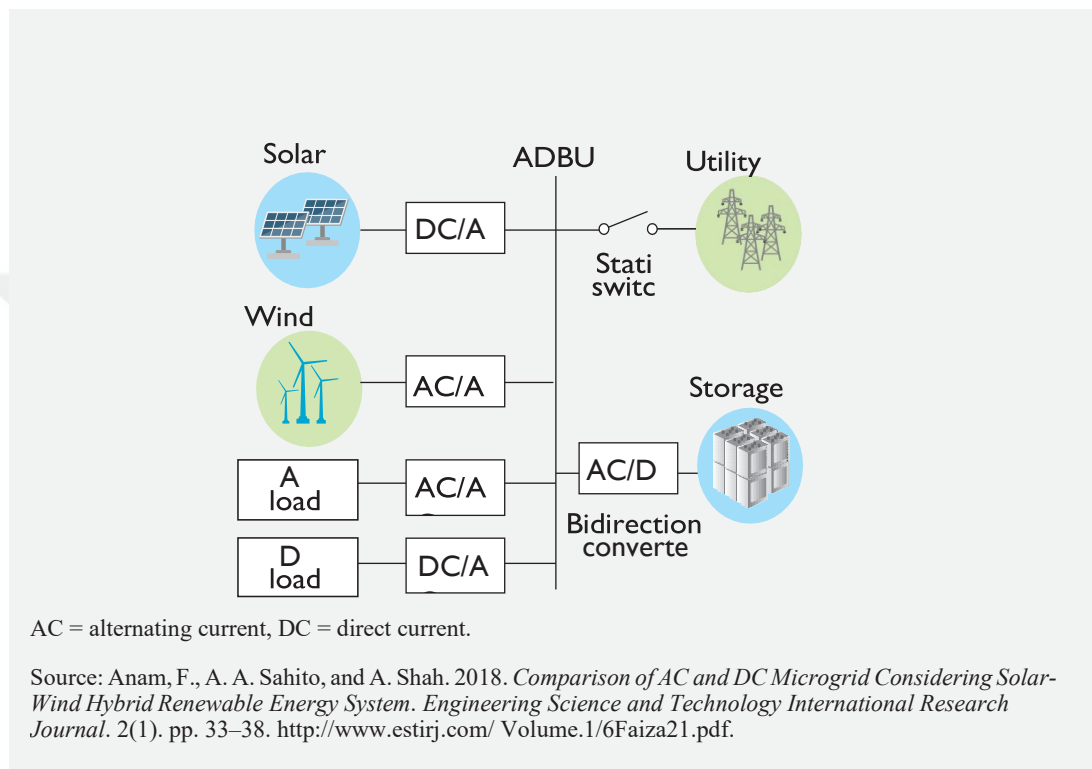

Figure9: Schematic of an Alternating Current Microgrid Bus with Solar and Wind Generation

**b) DC microgrid.**

The DC microgrid operational norm is similar to an AC microgrid; in all cases, the DC transport is associated. DC microgrids can also be operated in matrix-related or detached modes, like AC microgrids. While the expenses and system setbacks are typically greater, they are much reduced in view of the direct interaction with DC loads due to the impact change on the one-story system. In the future months, DC microgrids will most likely be dominated by a number of operational points across AC microgrids. The age and course structure for DC microgrids mostly incorporates PV units, wind turbines, electricity gadgets and other practical energy sources. The DC yield voltage

and the voltage rule is best used by its accumulating devices. Since there is no need for repetition control, there is no need for further structural synchronization.

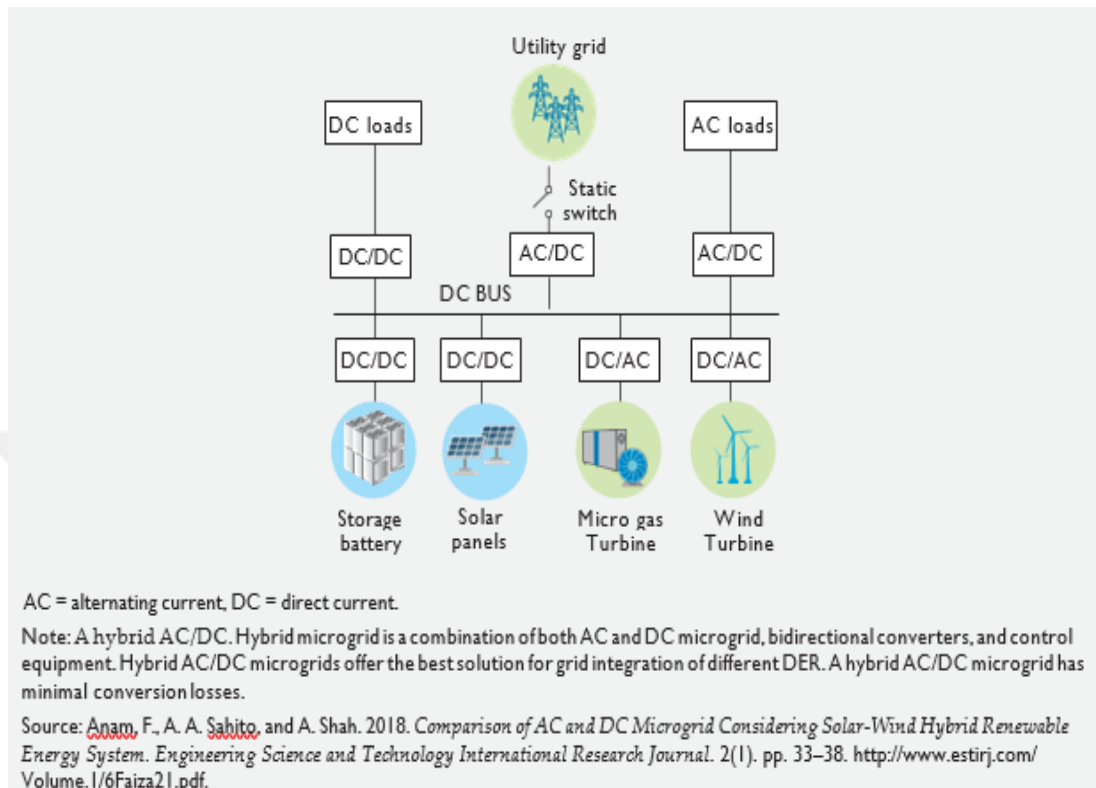

Figure10: Schematic Diagram of a Direct Current Microgrid using Solar, Wind and Micro Gas Turbines

### c) Hybrid (AC/DC) microgrid.

A Hybrid microgrid is a mix of micro grids both AC/DC, bidirectional and controlling equipment. The optimum response for grid joints from diverse DER is hybrid AC/DC microgrids. A hybrid microgrid AC/DC is unfortunate about changing.

The useful electric force has been a test for networks and modern or business foundations without permission to a strong utility framework. They have expected to rely upon the motor or turbine-driven generator sets that, while especially strong, consistently produce power at significantly more prominent cost than a huge utility.

As of now an unrivalled model is emerging that combines as of late reasonable harmless to the ecosystem power from wind or sun-based sources with common diesel- or gas-stimulated age. These foundations, called crossover microgrids, moreover use

energy amassing to add power structure security and engage further energy cost decline.

Aided by sharp abatements in the cost of wind and sun-controlled energy, similarly as lower energy accumulating costs near with the expense of fuel, hybrid microgrids are proper to a huge gathering of uses, including particular designs, resorts, mine objections, distant towns, little islands, and others. The most promising applications are those with supreme power interest from 100 kW to 20 MW.

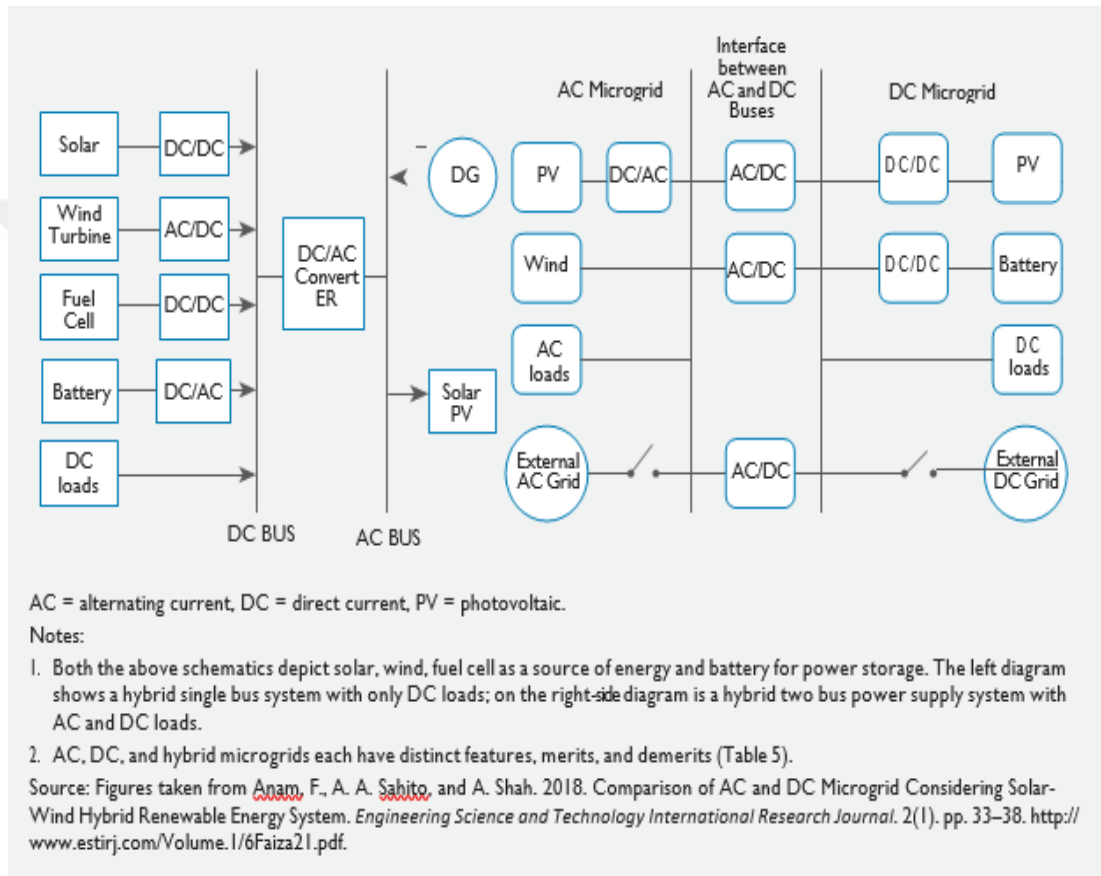

Figure11: Typical Block Diagram of a Hybrid Alternating Current/Direct Current Microgrid

### C. Microgrid Basic Components

- Generation locally: A microgrid provides several kinds of old sufficient sources to feed customers with strength, warming and cooling. The two key sources – warm energy sources (e.g., fuel gas or biogas generators, or less than expected combined warmth and power) and endless age-hot places – are divorced from these source sources (for instance wind turbines and sun based).

- **Efficiency:** Uses inside a microgrid merely indicate segments that consume strength, heat and cooling that, due to controlled weights, ranging from solitary contraptions to design lighting and heating systems, business centres, etc., power consumption may be adapted to the association's requests for use.
- **Storage of Energy:** In microgrids, power storing can play out various limits, for instance, ensure quality of electricity, including repeat and tension rules, the smoothness yield at supportable force resources, giving support ability to the structure, and expecting a basic occupation in cost improvement. It joins the sum of the substance, electrical, pressure, gravitational, flywheel, and warmth amassing advancements. Exactly when various energy reserves with various cut-off points are open in a microgrid, it is jumped at the chance to organize their accusing and delivering of the ultimate objective that a more unassuming energy amassing doesn't deliver faster than those with greater cut-off points. Additionally, it is supported a more unassuming one doesn't get totally empowered before those with greater cut-off points. This can be refined beneath an arranged energy control reserves reliant upon their state of responsibility. If different power storing structures (Perhaps managing various headways) are and are being utilized compelled on an extraordinary regulating Unit (Systems of Energy Management - EMS), reformist check reliant upon specialist/savant designing Can best assure undertakings, In the islanded mode in particular.
- **Common Point of Connection (CPC):** That's where a microgrid is in the electrical circuit related with the foremost cross section (principal lattice). Microgrids that have no CPC are known as isolated microgrids that occur normally found at faraway objections (example, distant organizations alternatively faraway current districts) where an interconnection with the principal framework isn't possible as a result of either particular or monetary necessities.

#### **D. How Does a Microgrid Work?**

To see how a microgrid functions, you initially need to see how the framework functions.

The system interfaces homes, associations, and various constructions to central electricity sources that allow us to operate machinery, heating and cooling buildings, and equipment. This connectivity does, however, mean that everybody is affected when part of the grid has to be fixed.

A microgrid can assist here. An all-round microgrid is tied to the system, but may, in the middle of crises such as storms or power failures, cut and function alone for various causes.

An infinite number of resources such as a solar organized sheet may be restricted by circling generators, batteries or imaginably. A microgrid may run uncertified, depending on how it is strengthened and how its fundamental elements are handled.

A microgrid interface with the grid under a usual connection, which retains the voltage as an important organization at a comparable level, unless if there is some type of problem with the structure or motivation to detach. A switch can usually or genuinely isolate the microgrid from the vital cross-section.

## **E. Microgrid Benefits and Difficulties**

### **1. Benefits**

A microgrid may run in autonomous, grid-related modes and manage progress between the two. Subordinate organizations can be organized through trade between the microgrid and the core structure in the organizational method. There are other potential income streams. The certified and responsive power inside the microgrid in the islanded modus, including that provided by the structure of the energy accumulation, should be in line with the interest of neighbourhood charges. Microgrids are a decision to alter the requirement to lessen oil derivatives by providing reliable electric energy in times when maintainable energy sources are not open. Similarly, microgrids provide security against actual environments and dreadful occasions by not having huge assets and thousands of wires across the grounds and other electricity supplies which need be maintained or mended after such catastrophes.

A microgrid may advance between these two modes considering arranged upkeep, defiled power quality or a need the host framework, blemishes in the close by grid, or for moderate reasons. By strategies for shifting energy direction through microgrid parts, microgrids energize the fuse of practical force, for instance,

photovoltaic, wind, and energy unit ages, without requiring rethink of the public assignment system. Current smoothing out techniques can similarly be melded into the energy microgrid the board improving system viability, monetary issue, & adaptability.

## 2. Difficulty

Micro-grids, and the joining of DER stations overall, present different operational incites that ought to be tended to in the arrangement checking and security to guarantee the Systems current Confidence levels are not basically and the afflicted normal Distributed generation (DG) units are beneficial totally outfit. A part of these challenges rises up out of speculations usually applied to standard course systems that are not, now generous, while others are the delayed consequence of solidarity issues once in the past saw unmistakably on a transfer structure stage. The far more outstanding. appropriate troubles at micro-grid security & check incorporate:

- **Power Pours in Two Directions:** The existence of flowed age units of the (DG) association It can lead to low voltage levels modified force streams which might provoke challenges at confirmation co-ordination, troublesome force stream plans, issue ampere movement, And control of the voltage.
- **Dependability Problems:** Collaborations among the test game plan Units of the DG may make close by movements, requiring a cautious little agitating impact consistent quality assessment. Also, practices of advancement between grid linked and islanding (independent) movement methods in a microgrid make interim precariousness. Progressing examinations have demonstrated that a quick microgrid interface Current (DC) may be achieve the generally easier structure of management, greater energy-successful course, & extra current passing on limit concerning a comparable line evaluation.
- **Modelling:** Numerous ascribes of standard plans, for instance, the prevalence of three-stage changed conditions, in a general sense transmission lines inductive, & consistent loads of power, don't actually stay steady for microgrids, and in this manner, models ought to be overhauled.
- **Low Inertia or Sleepiness:** Microgrids have a trademark name with low inertia does it not equivalent for the mass electricity systems, where to go tremendous count for the facilitated sources ensure reasonably immense idleness. This keep

thinking about whether There's one basic degree for the force Microgrid electro-interfaced DG units. The Low Durability Structure Could incite outrageous repeat Icelandic mode deviations movement suppose an authentic check framework isn't executed. Sync generators are running a comparable repeat like the framework, in this way giving a trademark damping sway on sudden repeat assortments. Synchronverters are inverters that impersonate composed generators to give repeat control. Various decisions fuse accumulation of energy or a flywheel to vary the recurrence of battery control.

- **Vulnerability:** In the microgrid movement there is a great deal of weakness in the eye, on which the microgrid's moderate and reliable actions depend. High profile and environment are two weaknesses that further challenge this coordination in independent micro grids, where an integral time horizon is necessary to handle the important premium balancing and the often-greater level of in satisfaction. Due to the reduced weighting and the accompanying supply of open energy supplies this vulnerability is larger than that of mass power systems (the averaging sway is extensively more confined).

### III. MICROGRID CONTROL

There are two distinct ideologies that may be distinguished in relation to the microgrid control plan or any control problem: *Combined* and *Decentralized*. Totally integrated control depends on a ton of transmission of information across units before a single decision is taken. The use of linked strength structures and broad geographic regions is cumbersome since they incorporate innumerable units. On the other hand, each unit is obligated by its closest control without having any knowledge of the circumstances under a completely decentralized control.

#### A. Techniques of Basic Control:

There are a few control strategies for dealing with the conveyance framework component level:

- *Control of master and slave:* The master fixes the estimation of voltage and frequency, and the slaves regulate the current sources.
- *Current control and power flow:* By using control signals this technique regulates current and power circulation.
- *Droop control:* The tactic is an increase technique joined along past strategies since converters carry on as non-ideal voltage sources.

#### 1. Central Monitoring:

Focal (Central) regulator is used for appropriated Detectors, drives, neighbourhood (local) Overrides, and a Support correspondence association. Information assembled by the scattered detectors are transported off then brought together controlled through the correspondence association. At the point when the focal regulator collects the information, it registers the control variable and deliver it to local regulators for each control equipment. neighbourhood regulators (local controllers) never perform dynamic and every one of the decisions are made at the nearby regulators.

## **2. Control Decentralized:**

The circulatory system is separated to small associations termed microgrids under a decentralized control strategy. A microgrid can have its own controller and many neighbourhood groups. Each unit (DER) in a microgrid is required by its adjacent regulator in a wholly decentralized philosophy. A LC supervises many LAs which do not need communication among LAs. The control configuration is called circular right after the LCs establish a common resolution to the overall control problem.

Isolated action is a microgrid attempting a direct result of the broken thought of a harmless to the ecosystem power age. They make weaknesses in keeping a consistent voltage and recurrence yield. Thusly, this shows the essential of an exact weight measuring and burden the administration decentralized system. In any case, the field of creative minds is a completely decentralized methodology which demands considerable collaboration between the latter.

## **3. Control Distributed:**

Control decentralized and transmitted chips away at a comparable standard beside that scattered designing has correspondence with nearby organizations (LAs) and LCs. Conveyed controls dispense control endeavours and their connections to several DGs. These duties are dependent upon Various times interval assignments and involve a control movement. In a framework, when there are more units, The control circulated is problematic, unless when a request for control is made up. This procedure is used for the coordination of each unit. The appropriated systems mean to address an essential improvement issue in a passed-on manner with confined correspondence.

Control strategies have been conveyed to merge the model with precious processes, agreement-based approaches and techniques based on specialists. The growing interest in examining distributed control solutions reveals that movement and control of microgrids insulated, saves safety and protects the structure from cyber threats.

## **4. Hierarchical Control:**

There are two explicitly multifaceted and scalable views of the hierarchical control system. The control is necessary for layers in a multi-faceted idea and for each

display at various times. In order to synchronize the control cycle, the controller has unambiguous control levels. While the top levels manage the goals all over the earth with centres of control, the bottom layers control. The next regulator (LCs) is controlled in an incredible way and their movement consists of an extra unit with the (MMC) Main Grid Main Controller. The check from one to the lower levels and the related is essential A compromise among incorporated and decentralized control plans can be refined by strategies for a progressive control plot including three control levels: essential, optional, and tertiary.

The essential reasoning behind this level controller is that the electronic converter is directly controlled to maintain voltage and recurrence, while the optional levels are confident to ensure coordination between the adjacent controls (nearby controllers) and moderate tension/recurrence deviations, which are caused at the control level. At the third and major levels, the control unit chooses the best power stream to provide balance between demand and creation in all the faults of the power association.

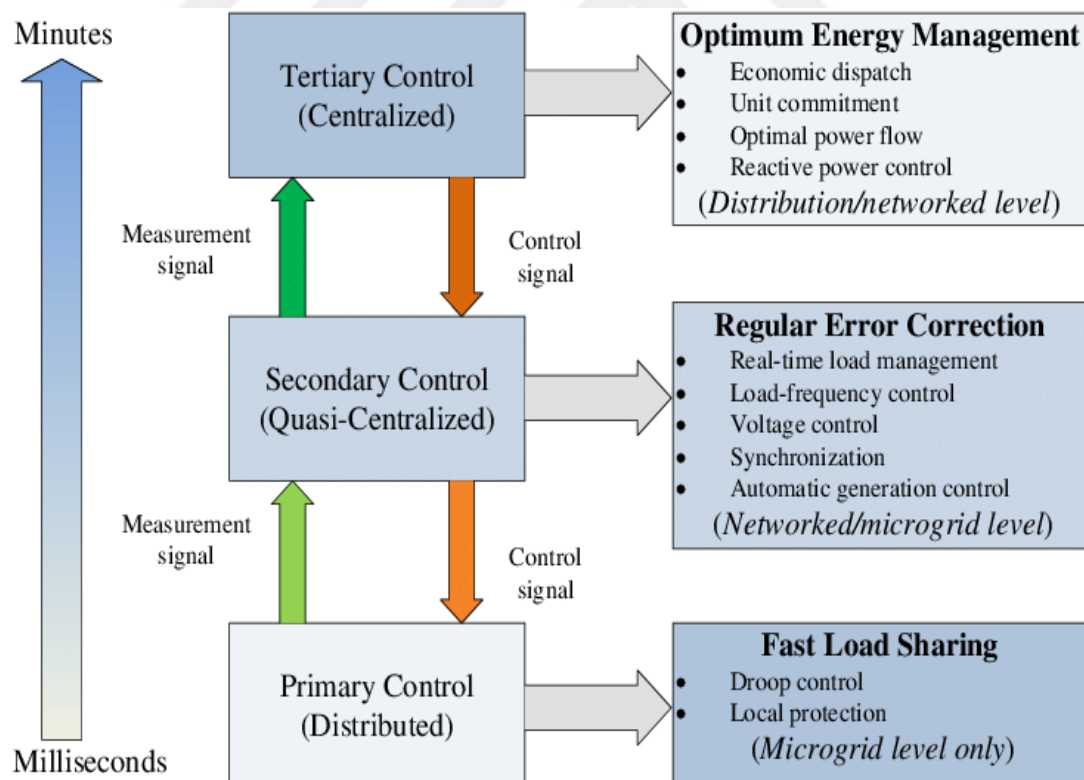

Figure12: Illustration of Hierarchical Control at Different Stages.

### a) Primary control [P/Q (active/reactive power) droop checking]

The initial level of hierarchy with the local controllers is primary control. The principal control is designed to meet the accompanying requirements:

- To balance the tension and frequency.
- to provide plug and play capacity for DERs and to adequately split the dynamic and reactive power amongst them preferably without connection.
- To alleviate the flow of the electrical devices causing the over current phenomena

The main control provides the setpoints to a lower controller consisting of the DER voltage and power control rings. These internal control rings are always referred to as zero-level control. You must react swiftly to the problems of force structure with the least or no transmission. The main task is to insulate and manage voltage/recurrence. Especially essential control may be structured into a control ruler/slave and appropriate control requiring the establishment of transmission interfaces and different Droop classes without transmissibility. Since control of the rule/slave needs greater channels of communication information move limits and it lessens the constancy if there ought to emerge an event of disillusionment of a single reason for the association, the comprehensively changed strategy is hang the check. The Voltage Source Inverter (VSI) controllers conduct fundamental control.

Each inverter will have an external forces circle, also referred to as autonomous or decentralized control, which will divide the dynamic and the decentralized controls open (dynamic and receptive) Power between DG units and to improve the organization execution and strength, changing the recurrence and the size of the output voltage simultaneously. The plan for hang control might be given as;

$$\omega = \omega^* - m(P - P^*)$$

(Equation 1)

$$E = E^* - n(Q - Q^*)$$

(Equation 2)

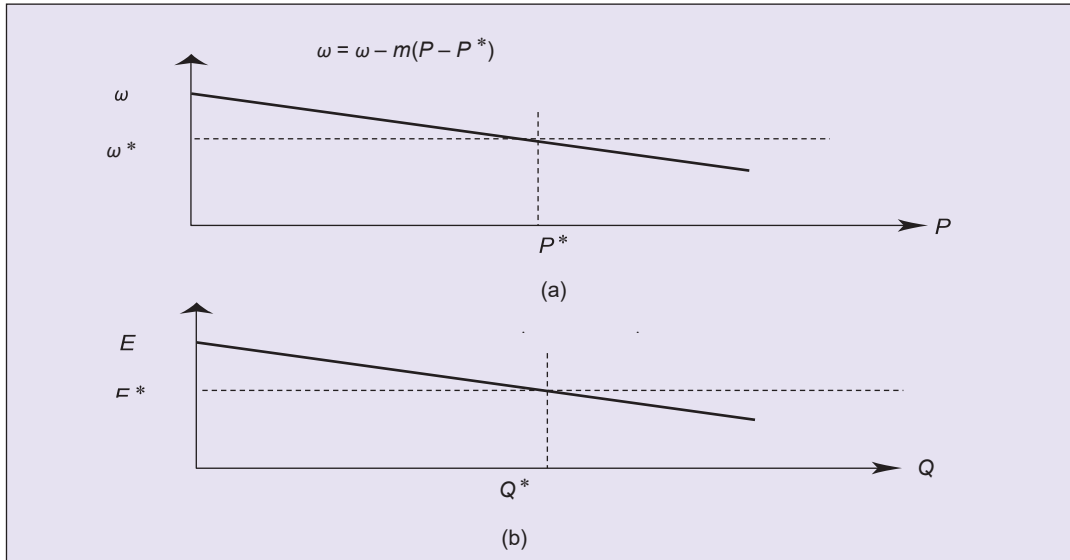

Figure 13: P-X and Q-E Grid Scheme using  $P^*$  and  $Q^*$  as Set Points.

In both cases, the frequency, the amplitude and the coefficients  $\omega^*$  and  $E^*$  determine the appropriate slopes. The frequency and amplitude of the output voltage are correspondingly.  $P^*$  and  $Q^*$  are the active and reactive power references are usually set to zero when UPS units are connected independently to the energy island.

However, the utility organization is essential to establish both dynamic and reactive power sources to draw from the unit if it is to supply capacity to predictable force sources. This Droop approach increases the execution of the network since it enables independent mobility across the modules. Thus P/Q sharing through a self-regulating segment, which employs the dynamic and responsive nearby force of each device, can impact sufficiency and the repetitive yield voltage.

The repetition and amplitude yield voltage should be aligned in the control circle to ensure remarkable force sharing, with a view to compensating for the dynamic and responsive weightiness of the force. This is based on the good high-power network theory, in which the recurrence of generators decreases when the utility grids are stretched.

The matrix impedance is fundamentally inductive in transmission organizations; this is the reason why P -  $\omega$  and Q - E are utilized. The inverter can therefore provide the chief organization with the dynamic and open capacity needed, adjust the yield voltage and react to variations in the load. In any case, when using power equipment converters and low-voltage microgrids, the impedance is unnecessarily far away to be inductive.

The Droop control of the multi-loop plan that showed up in the Figure underneath is made out of an external circle whose limit is to deal with the yield voltage, however the internal circle coordinates the current inductor or the current condenser of the yield channel(filter) to show up at a speedy one-of-a-kind response. This control figure gives high sensibility in limits plan and a low total consonant bowing; notwithstanding, Both demand complexity examination and a limit Syncing estimation. Moreover, a second one. appropriate perspective to give real yield impedance is the virtual yield impedance circle.

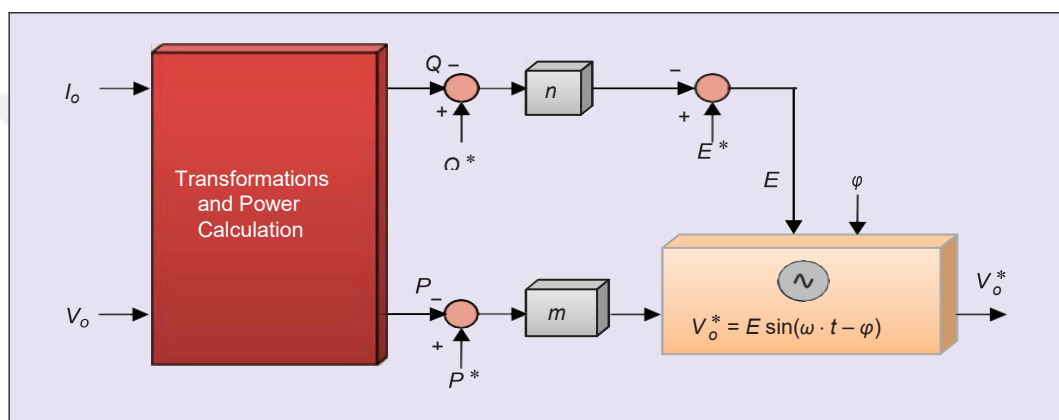

Figure14: Droop Control using P/Q

#### i. Virtual impedance loop

The shut-circle inverter's yield impedance affects the precision of force share and selects the hang control technique. The genuine configuration of this impedance of rates may also lessen the influence of the imbalance of the line impedance. The voltage reference compared to the output current may be eliminated in order to program a constant yield impedance. This quick control circle may deduce the output impedance of the inverter from the voltage reference of the internal control circles, as presented on the figure below, by subtracting a fragment of the input current from the voltage reference. Moreover, hot exchange movement, i.e., the relationship of additional UPS modules without generating a huge current turbulent effect, might be enhanced by programming a high-return impedance with the UPS when it relates to the microgrid and subsequently continually decreases to a true value.

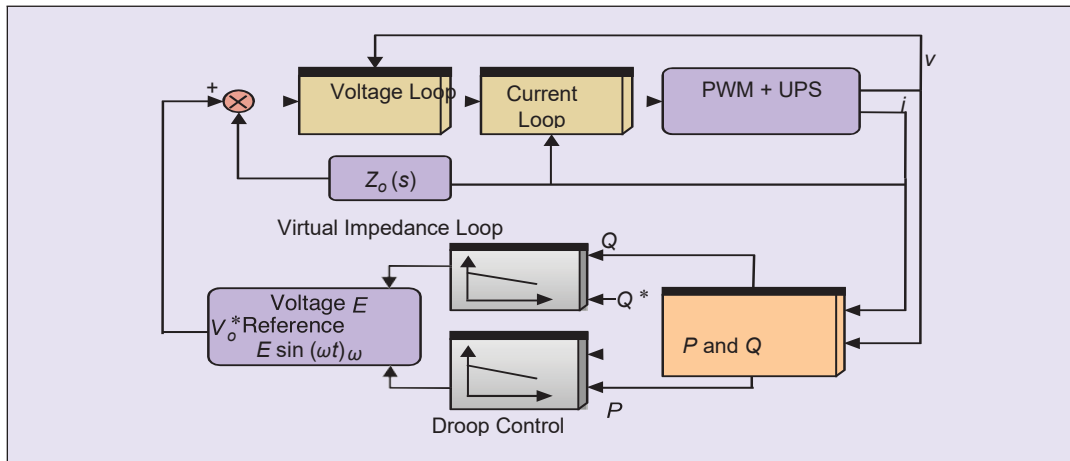

Figure15: Multiloop Control Drop Scheme with the Impedance Approach to Virtual Output

The inverters should be adjusted as a control inner circle to act as generators by incorporating virtual inactive characteristics by hanging technique methods. As part of the ideal dynamic and responsive force it unambiguously alters the repeat or abundant yield tension. The dynamic and responsive power between the inverters may therefore be divided accordingly. The voltage rule is essential for consistency and to ensure closer tension. The majority of DG devices may show open power and motion voltage movements without this monitor management. To prevent this fact, the DG's open power age is more capacitive, which decreases the voltage limit. High orbiting streams between the sources should also be executed by the voltage regulator. With that in mind, when Q is a high inductive value, as shown below the voltage reference value will be expanded.

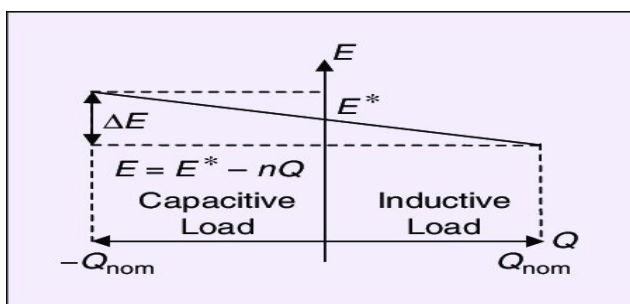

Figure16: Droop Feature for Capacitive or Inductive Load Supplies.

## b) Secondary control: restore and synchronize frequency and voltage

Restoring the microgrid voltage apparent characteristics, the chairman organization ought to give the relating signs using low-information transmission correspondence. This control can also be used to synchronize the microgrid to the basic

matrix ahead playing out the interconnection, making a trip from islanded to organized mode. A static combination of  $\omega - P$  and  $E - Q$  is a force spread across the control phase, and is performed as the hang plot. Similarly, recurrence and voltage rework should be modified in accordance with their apparent features if a pile change is resolved. The recurrence differences from the apparently evaluated recurrence network first lead to the usage of an integrator. This dislodging cannot be done comparatively for certain equivalent sources due to assessment goals. Similarly, if in isolated mode, the forces sources are associated by the main grid at distinct events, the direct heap cannot entirely be assured in view of how remarkable all the fundamental (genuine) conditions of the integrators are. Therefore, it is vital for an external aid supervision to monitor repeat differences and adequacy and offer important references to increase the balance credits for each DG unit (see Figure beneath).

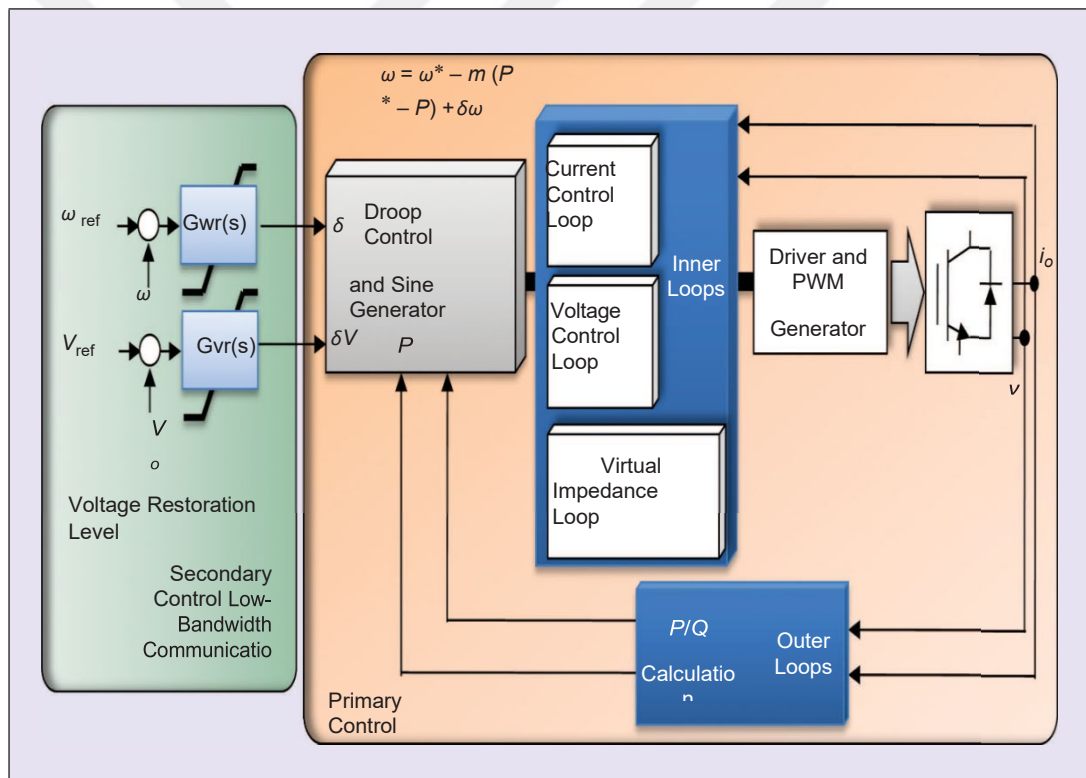

Figure17: Control Primary and Secondary Based on a Plan for Hierarchical Management

**c) Tertiary control (P=Q importation and exportation):**

The difference in the references of an inverter with the microgrid and even with the MPPTs of the generator is carried out in the third level control circle so that energy flows are smoothed out. Depending on the control of the force stream, the microgrid

inverters can be altered widely (microgrid imports / transfers power) (levels of leadership of consuming exertion). Regularly, the force stream depends upon money related issues. Monetary data should be structured and used for microgrid choices. Every controller should react independently to changes to the system without the need for load data, IBS or multiple sources. In these lines, P and Q implanted to control by the organization are used by the helper control (see Figure beneath). For example, P references may be adjusted to acclimatize or infuse P into the organization as a positive or negative cause, and Q references may be set to nil to achieve force factor. The controller sends the recurrence and enough references to the control option, and splits them into the microgrid with the greatest limits and the lowest permissible values. Extra features such as insulating recognized proof or symphonic drop of voltage of the system by consonant imbue ment may be obtained with this control level. The microgrid may therefore be completely compelled by employing a surprisingly distinct, even-out strategy which disperse and decentralize control mechanisms. The performance is linked to the creation of correspondence and future knowledgeable network codes.

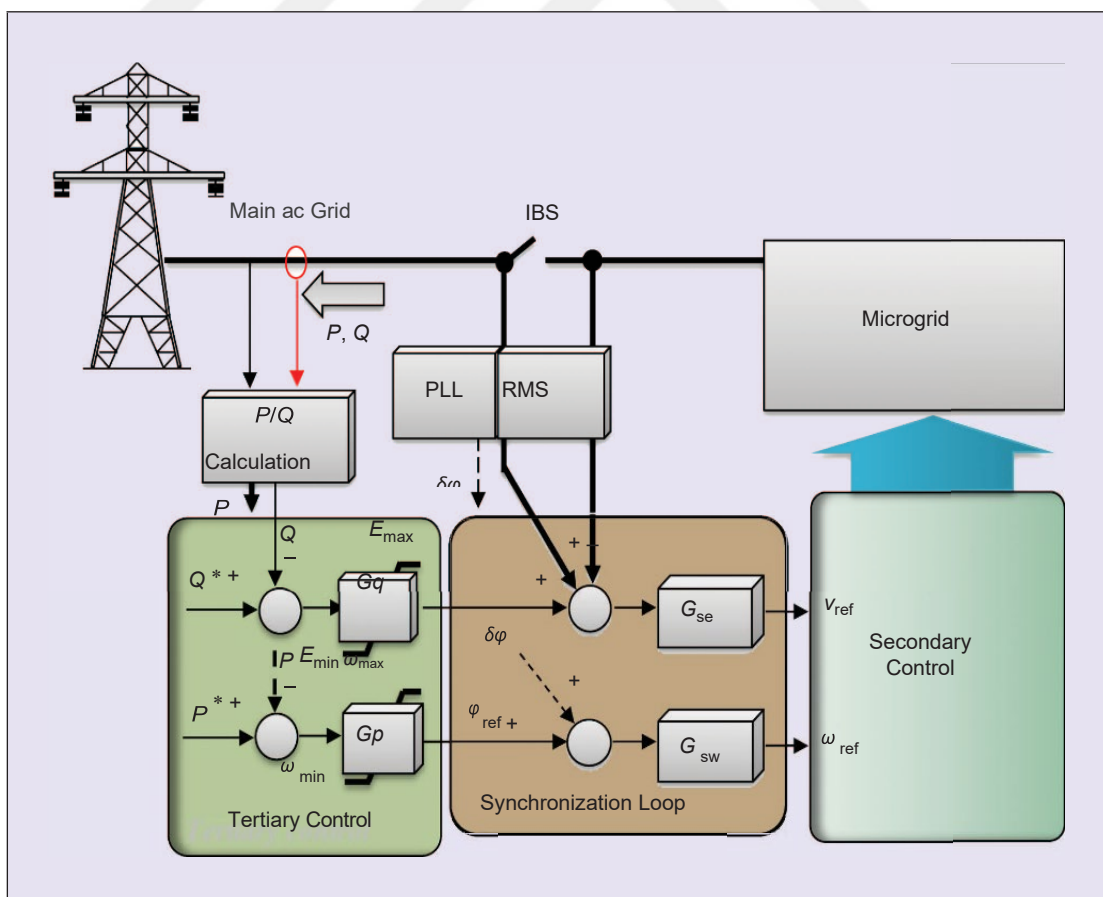

Figure18: Tertiary Control Block Diagram with Control Loop Synchronization.

## **IV. MODE OF MICROGRID OPERATION**

### **A. Mode of Operation Connected to the Grid**

In both movement modes, i.e., with and without a link with the public framework, microgrid energy control should be handled by considering energy collection structures and energy stream control. In this regard, the microgrid should be good to transport/acquire energy from/to the vital network for the control and management of dynamic and receptive forces streams. The system components are fixed to a huge degree, due to the lattice size of the DG devices, in the matrix-related mode. Another problem is that the control signals are moderated when there is a difference in the yield power. In the absence of synchronous machines associated with the LPM, virtual latencies inside the electronic force interface control cycles are required. In addition, power accumulation contraptions such as batteries, supercapacitors or moving wheels should supply the change of force throughout the transitory period. Following a blackout, the microgrid should start to conduct itself successfully and amplify conditions similarly to the loading of partners and DG units by a reformist request (dim starting action). In this method of action, all DG units should also supply a pre-determined force to, e.g., to limit the force from the structure, which depends on the general energy of the system of the chief. Each DG unit is also regulated by means of a correspondence transport by voltage rule for a dynamic and responsive power age. Usually, the major bars send all capacity to the piles alongside their DG units depending upon customary dysfunction while the microgrid is in system-related mode.

### **B. Insular (Islanded) Operating Mode**

In two cases, the microgrid can be divided in:

- Island activities pre-planned: For example, if occasions are presented in the main framework with long-term voltage sinks or general weaknesses, the island activity should be started, among alia.

- Island activity unplanned: If you have a power outage because of a separation of the fundamental grid, the microgrid ought to have the option to identify this reality by utilizing legitimate calculations.

The system elements in isolated mode are represented by their own DG units, which usually regulate the micro-recurrence grids and abundance voltage. There might also be a slight difference from the apparent recurrence and sufficiency. DS units will thereby sustain all unique strength imbalances by injecting, or maintaining, dynamic force in general. The IBS will be opened to operate together, and the microgrid will be removed from the main organization (fundamental matrix). In the case of an islanded microgrid, the DG units which feed the system are adequately charged with apparent tension and sufficiency of recurrence when strength is shared with the creating units (age). It is moreover essential that the inverter is not over-stopped and that the changes in the stack are checked in a real design. Some control methods rely on transmission units as a slave plot that may be embedded in buildings with comparable DG units in the vicinity. In any event, communicating via a low-bandwidth technology may be more monetary and attractive. The microgrid should also be able to solve the problems in self-administered mode:

- Voltage and frequency control: The framework is used as a voltage source, the force control pipes are modified and guided into acceptable cut-off locations as a form of viewpoint.
- Adjustment of supply and demand: the DG units' frequency is fixed by the network in network-associated (grid-connected) mode. A new dynamic power set may be achieved by changing the frequency of the setting, changing the angle of the power slant between the grid and the microgrid.
- Quality of electricity: The quality of electricity may be set on 2 levels. The first level is the receptive power compensation and the consonant power sharing within the microgrid and the second level is the reactive power and symphonically pay of the CPC.

Also, all DG units are constant sources of energy, which infuse optimal power into the utility framework if the microgrid is running in an island fashion.

### C. Progression Between Grid-Connected and Islanded Mode

As recently mentioned, both the utility structure and microgrid status are controlled consistently by IBS (see Figure beneath). Right when a force supply conclusion happens, or the IBS has detected a fault in the main grid, the microgrid should be removed and whatever quantity may be relying on to assure high trustworthiness, the reconstruction cycle should be decreased. In this situation, the force reference may be adjusted to apparent characteristics, notwithstanding the way that it isn't cautiously significant. Additionally, if the most limit acceptable deviation isn't outperformed (consistently, the microgrid can analyse voltage adequacy and recurrence of 2 percent for recurrence and 5 percent for sufficiency and movement ( $P$  and  $Q$ ) centres may avoid recurrence and Droop system abundance). If the microgrid is insulated and IBS decides principal network inadequacy free relentlessness, synchronization among voltage, adequacy, stage, and recurrence ought to be recognized for interfacing action. The revamping strategy zeroed in on the plant restart, structure recurrence synchronization, and force creation of the chief matrix. During this stage, a couple of nuances ought to be considered, for instance, the responsive force balance, replacement of the transient voltages, changing force age, starting progression, and coordination of DG units.

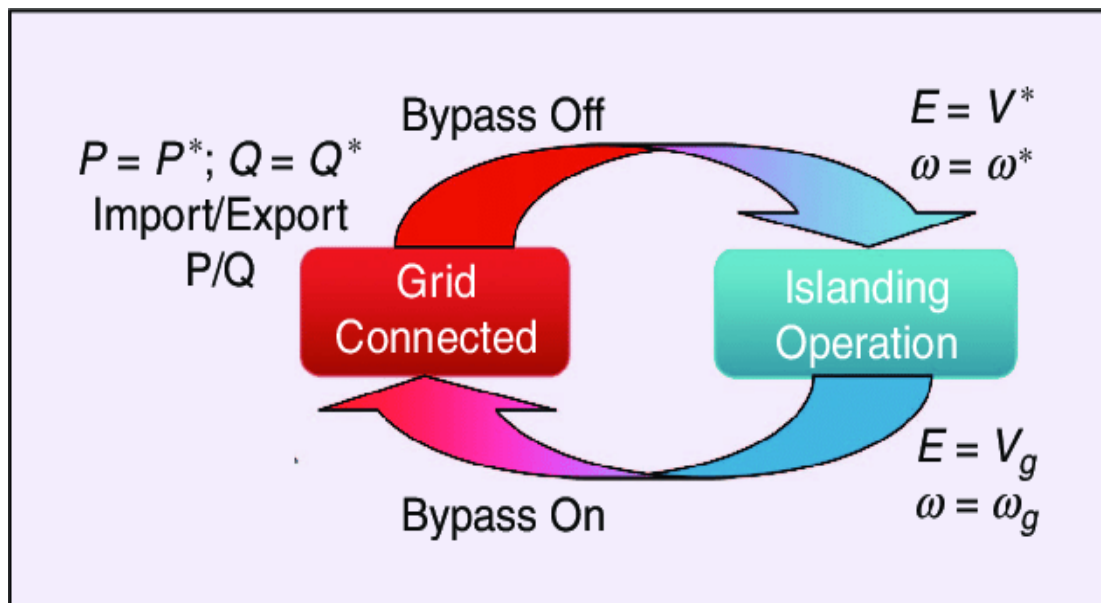

Figure19: Flexible Microgrid and IBS Grid Status Monitoring Operating Modes and Transitions

## **V. MICROGRID OPERATIONS AND MAINTENANCE.**

Two functioning modes exist for a microgrid in the organization. The usual mode of work is the mode connected to organization. Each feeder is offered in this working manner by the service or primary network, and the microgrid routinely works as long as there's no way force Disruption of quality on the principal system. In any case, when there is an inadequacy of other force disturbance on the primary organization, the microgrid will be withdrawn from it (in an orchestrated or off the cuff way). This is implied as the "islanded" or "separated" technique for action. Such advances, close by keeping up structure sufficiency and weakness disclosure are three essential zones for suitable microgrid movement.

### **A. Maintain Stability and Synchronous Operation of the Microgrid System**

In view of the inconspicuous portion of microaggregates, the Primary Force Network co-ordinates the overall structural components. In network-related mode, therefore, an adequacy analysis of a microgrid is the same as the larger force framework with which it relates. Then the system components in an Island microgrid motion are again shown in the DGs, which might create a problem with the microgrid's production activity by varying yields together with changing the weight. The trustworthy action of a microgrid in cross sectional modes is commonly utilized by three levels of regulatory control — flow, microgrid level and neighbourhood level. At the level of the distribution the chairman and head of the flow network (CNA). MCC manages the level control of the microgrid and control of the unit level is carried out by controllers. DNO and the market supervisor provide signals at the level of the transmission. For the microgrid with the primary system, MCC manages correspondences between the DNO and the controller closely. Regulatory control of the microgrid as illustrated in the latter half may be decentralized or unitary.

If a microgrid operates in networked mode, the service provides a positive, reliable voltage and recurrence reference to keep the compounded microgrid activity up - i.e., the utility is the isochronous generator reference, and all DGs and limits work

in hung mode. However, if insulated from a gate, it has to rely on its own internal assets in order to maintain a quality of power and force any adjustments to structural voltage levels in any event. As of now, several island microgrids use warm generators or NG generators that fill this isochronous reference with synchronous machines, equally as a reactive power supply and can monitor structure voltages, while different generators, Photovoltaic inverter and battery inverter sometimes work hanging. There is, however, a further requirement for island microgrids that function at an economic age. These constructions are frequently completely inverter-based and have no spinning generators. Their use should now be made from a sharp battery storage inverter, which works in the voltage and recurrence control mode in order to deliver a powerful, continuous voltage rule, in a manner similar to the one used in other devices such as STATCOM. The management of this cycle is one of the middlemen of a microgrid that is completely unlimited.

## **B. Inaccuracies**

A lay electrical defect is an amazing stream on the network which may come out of a variety of circumstances, including short circuits. Standard Usefulness system strategies for weakness area don't make any difference to microgrids in view of the bi-directionality of power stream, the need to perceive network-related and islanded action modes and the converters interfacing the DERs give confined blemish current stood out from a segment of the stuff and mechanical assembly this could be on the microgrid. Lack of protection area and plan structures are really important micro grid premises and there is no standard single-size action at the present time. With a series of methods or mixes that employ differential protection, exchange systems and advanced signs for estimates, the arrangement and cycle is constantly altered to the particular microgrid.

## **C. Costs of Operation**

Operating expenses may be contrasted in a microgrid and largely have fixed and variable components. Taking carefully account of operating costs, i.e., excluding maintenance costs, staff payment and overall and legitimate expenditures are consistently based on fixed costs; and variable energy generation costs are the most important element of the micro grid's tough and quick cost of force. Therefore, the

overwhelming and rapid energy costs in the microgrids are sufficiently high, regardless of the energy picked up by the utility, in short, any share of the utilities for the exchanges of power or the networks provided for by the utility. the LCOE of the constituent DERs (by the control of dispatchable age sources and DSM of controllable versatile weights). That means that the operating expenses of the microgrid depend entirely on the optimized arranging and dispatch of all these limitations during action by means of the cash-related expenditure.

#### **D. Maintenance**

As by virtue of some other thing or structure or establishment, standard help and upkeep are principal to ensure strong execution over the reasonable working existence of a micro-grid. For this, it will be caused by fixed costs (e.g., subsidiary pay rates) and variable costs (e.g., direct cost of the element to be included in substitution part expenditures and by indirect costs to replace substitute support creation over time). Help strategies & techniques for micro-grid are commonly finished by O&M laborers, considering set up shows and ranges, for instance, infrequent general upkeep, booked preventive upkeep, and data assessment based judicious help. Given that there are a couple unmistakable microgrid applications, with moving assistance necessities and cross section accessibility circumstances, No one fits all No one cure, and what about the help expenses ought to be stood out from the expenses of disillusionment aggravation, risk reduction potential, and steadfastness overhaul, to deliver an assessed money related estimation, for instance, a rate or incomparable threat decline per dollar or cost just as adventure.

The assistance activities and costs of microgrids are mainly those of their various components, such as unlimited or non-sustainable round creation sources, batteries, microgrid control systems, sensors, correspondence associations, distribution structures, protective equipment, transformers, and electrical components. In sun-controlled PV systems, for instance, help techniques are detailed from relevant sources, with annual maintenance costs normally about 2 % of its original cost.

As in most operating plants, O&M operations may be carried out by an O&M legal worker or the integrator who created the plant without aid from another person, each with its possible rewards and disadvantages. This view typically arises at the

financial stage as part of the proper output of microgrid architects and supervisors in terms of general constraints and validity.



## **VI. MICROGRID PROTECTION**

The perspective for security is to have comparative affirmation philosophies for both islanded and organization associated(grid-associated) action. The static switch is planned to open for all defects. With the static switch open, inadequacies inside the microgrid ought to be cleared with strategies that don't rely upon high-issue streams.

Security is a critical segment in an arrangement of micro - grids. For the microgrid, it is necessary, all things considered, similarly with respect to Controls at cycle level. It should work rapidly then purposely modified into isolation among framework related and islanded working modes. In a cross section tied strategy for movement, the affirmation is unravelled by the conceivably tremendous blemish streams, while these lack streams may have decently inferior qualities in the islanded mode in view of facilitated power devices Microgrid interfaces. Such a low-current cut-off in island mode is not enough to safeguard usual overtime. A customizable security structure is therefore needed to repeatedly adjust movement parameters to ensure that the microgrid is continuously maintained. Advanced movements with a correspondence structure to create the micro-grid might be used for another game plan. The microgrid can be designed to be in isolated mode in a poor circumstance before any assertion moving occurs as an easy way to resolve this protective problem (OUDALOV, 11 November 2009).

### **A. Protection Schemes of Microgrid**

The coordination of conventional protection transfers as independent units with fixed settings depends on the working season of the essential and reinforcement assurance (Figure beneath). This plan of power system protection can't adjust to the adjustments in geography and activity mode. Reports have shown that the customary assurance plans have a primary part in significant power outages of power frameworks. Subsequently, the interest and structure of the dispersion organization, just as the idea of the dissemination framework, have changed with the high infiltration.

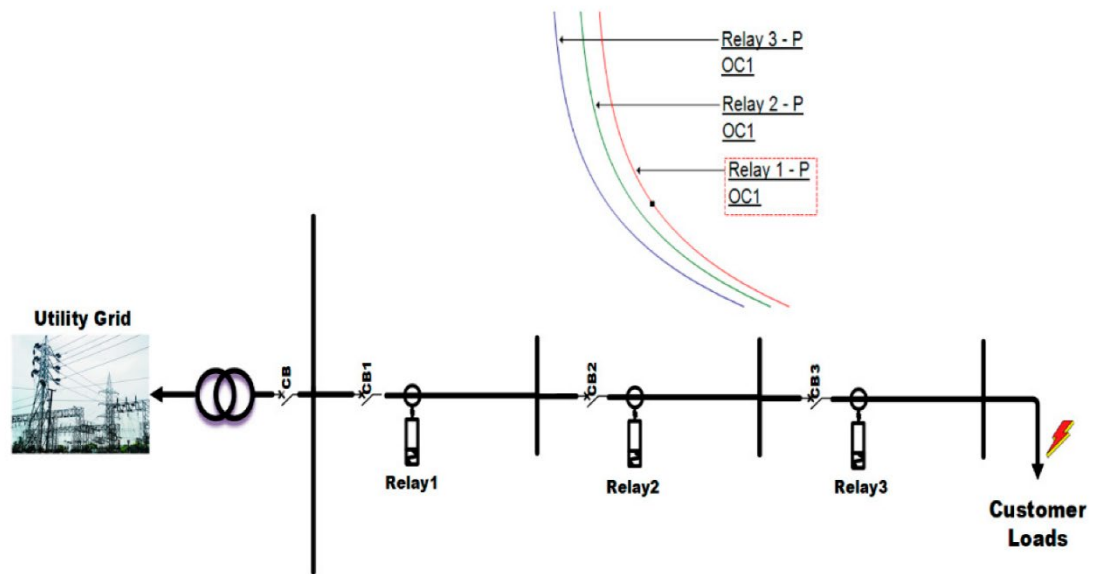

Figure20: Traditional Coordination of Protective Relays

The significant difficulties of the dissemination network are related with the adjustments in the idea of the microgrid. Numerous plans have been proposed to ensure the appropriation network with high infiltration of assets.

### B. Impedance-Based Protection Method:

An impedance-based assurance system guarantees a transport network inside seeing DGs. Issue territory is surveyed by the impedance procedure reliant upon the assessment of voltage and current at the hand-off point or at the two places to pause. A distance hand-off is a protective contraption that measures the impedance of a line using the voltage and current at the exchange point. Distance security doesn't normally need correspondence among moves. Simple or advanced techniques are used to recognize acceptance type protections. The enlistment type security can be used under the hurt or killed resistor conditions. Also, impedance-based security can be comprehensively used in resistor-grounded networks. Distance moves can unmistakably eliminate blunders quickly, in this way support keeping up the security of the system during conceivable outcomes. The figure under shows the different zones of distance moves. Distance transfers when in doubt cover three zones (Field 1, Field 2, Field 3). Area 1 of a distance transfer regularly covers 80% of the hot line and works right away. The other two (zones 2 and 3) are surpassing zones with time delay. Zone 2 of a distance move is typically proposed to cover the tied down line notwithstanding 50% of the briefest connecting line or 20% of the guaranteed line, whichever is more

conspicuous. Zone 3 gives support security to zones 1 and 2 of uncleared blemishes in touching zones (TAHA SELIM USTUN).

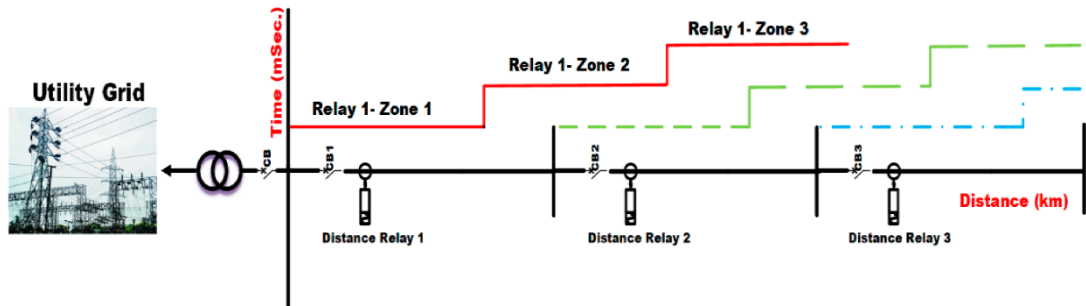

Figure21: The Zones of Distance Protective Relays

The impedance system is the most know head recurrence part-based strategy. this strategy can calculate the weakness territory without requiring any exceptional gear/programming by getting data. the high invasion of DGs changes the short out current level. the low issue current in inverter-based microgrids is for the most part a direct result of the inverter's controller and not in light of the force structure's impedance. the correspondence helped impedance-based security plot was proposed for inverter-governed microgrids. in this way, the colossal composition and wide existing experiences in arranging impedance and directional segments can be utilized in arranging these affirmation parts. the fig. underneath shows an impedance-based assurance plot with various movement resources.

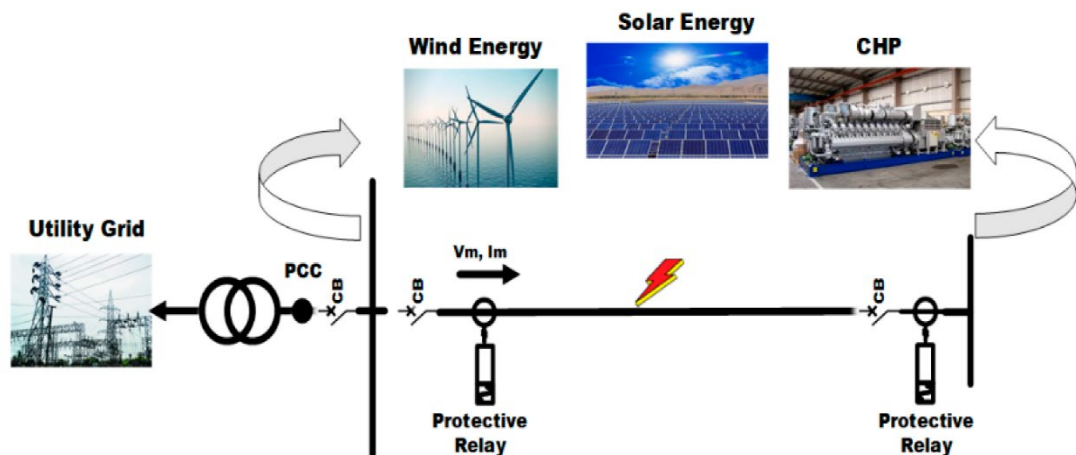

Figure22: Impedance-Based Protection Scheme

### **C. Adaptive Protection:**

The security system can't guarantee the force structure against certain changes. A flexible assurance plan (versatile insurance conspire) can change the hand-off setting/security need as shown by the new generally conditions, for instance, operational or topological changes. The force structure insurance is improved, and system security is redesigned by following versatile(adaptive) assurance thinking. The adaptable insurance plans are more fruitful for the security of such a force system. versatile security is "an uptime development which changes the supported guarded reaction to system circumstances change or essentials in a handy way using distantly created signals or control movement". versatile security has been made since the 1980s. Versatile security contrive handles the issue of both organization related and islanded techniques for movement. In a versatile assurance structure, there is a modified remedy of hand-off settings, when microgrid mode changes from lattice related with islanded and from islanded to arrange related.

### **D. Voltage-Based Scheme:**

The voltage-based procedure is another approach to get microgrids using voltage assessments. The procedure uses the voltage level point through the power system during inadequacies and is routinely applied as a support assurance plot. A couple of investigation works have depicted the abc–dq change to recognize voltage agitating impacts. The technique changes over the signs from ABC reference to a dq diagram. The yield voltages of the little source are changed into DC sums by the dq reference diagram. Any exacerbation at the small-scale source yield on account of the insufficiency on the cross section is reflected as agitating impacts in the dq regards. The proposed system can get both internal and external defects in a set zone of assurance identified with the microgrid. In this strategy, voltage is considered for the disclosure of issues and thusly for withdrawal. There are two procedures. One is the change procedure and the other is the consonant strategy.

#### **1. Transformation Method**

The DER's yield voltage is modified in two phases in this technique.

- Transforming ABC to DQ voltages

$$\begin{bmatrix} v_{ds} \\ v_{qs} \\ v_0 \end{bmatrix} = \frac{2}{3} \begin{bmatrix} 1 & -1/2 & 1/2 \\ 0 & -\sqrt{3}/2 & \sqrt{2}/2 \\ 1/2 & 1/2 & 1/2 \end{bmatrix} \begin{bmatrix} v_a \\ v_b \\ v_c \end{bmatrix}$$

(Equation 3)

- Transform the value from dq to dc

$$\begin{bmatrix} V_{dr} \\ v_{qr} \end{bmatrix} = \begin{bmatrix} \cos \omega t & -\sin \omega t \\ \sin \omega t & \cos \omega t \end{bmatrix} \begin{bmatrix} v_{ds} \\ v_{qs} \end{bmatrix}$$

(Equation 4)

- Any deficiency the condition is shown as an adjustment in  $d$ - $q$  esteem

$$\mathbf{v}_{DIST} = \mathbf{v}_{qref} - \mathbf{v}$$

(Equation 5)

By contrasting and the reference esteem, it tends to be effectively derived which sort of shortcoming and it very well may be disengaged. The utilization of changes is an elaborate cycle and gets intricate in certain shortcomings recognition. Indeed, even a little contrast decrease in tension on account of a brief line appears a significant impact upon insurance. Organization geography likewise assumes a significant job in the utilization of this strategy when huge quantities of DERs are available.

## 2. Harmonic Method

This technique increases terminal voltage when a failure occurs the total harmonical distortion (THD). The kind of shortcomings may be detected by contrasting the THD of the terminal voltage of the converter with pre-set benchmarks. In this approach, Fourier's discretion changes are utilized to change over the stage voltages  $V_a$ ,  $V_b$ ,  $V_c$  into the recurrence space. Utilizing a legitimate correspondence channel between the transfers, the flaw region can be found and segregated. This is utilized as reinforcement assurance. The correct position for the THD benchmark is often tested.

## E. Distance Protection

In light of the huge differentiation in the question streams in the organizational (matrix associated) and the island-based mode, the research has been dedicated to using the distance insurance to a microgrid, which depends on the impedance seen by

the transfer rather than on the stormy decision The DER output may lead the shops to reach understatement and compel the distance travels overwhelmingly. These problems can be addressed by employing additional distance transfers. The impedance of the transmission is affected by the absence of current which limits the notion of the DERs based on the converter. The current of the line leads to the voltage, given a recognition of DGs based on the motor generator employing SCIM (Squirrel's enlisting engine). It addresses the over-show in question to the relevant hand-off distance that measures it. DG, the power factor of the DG unit is required by the DFIM control plan during the circumstances of issuance because of a DFIM (Doubly taken care of the recruitment engine) based DG. In case of a lopsided defect and insufficiency streams are not large, the control system will undoubtedly be able to maintain DFIM's power factor. It can lead to problems like confirmation done by an inverter DG. This prevents the use of microgrid security distance movements.

#### **F. Harmonic Current**

The high penetration of converter-based passed on age has extended music levels in microgrid geologies. The force structure music depends upon the geology of the system similarly as the wellspring of consonant associations. Current transfers can screen total symphonious bowing of the inverter terminal, which can deal with the system concerning the consonant changes. The symphonious substance methodology is dominantly expected to guarantee the DG rather than the force structure. The consonant impedance is a basic factor in looking over symphonious release levels in electrical force structures. The procedure thinks about two techniques of data assurance. The two kinds of data assurance methods can be used together to cross-check the eventual outcomes of each other. The control philosophies of inverter movement in a substitute mode have been proposed in which all aspects of the microgrid consonant are settled. In this strategy, the symphonious impedance is assessed by mixing a current agitating impact.

## VII. HYBRID MICROGRID WITH PARALLEL- AND SERIES-CONNECTED MICRO CONVERTERS

### A. My Hybrid Microgrid Proposal

The system consists of two DG units equal. Every DG unit has a string converter interfaced with the PCC. A static exchange switch (SES) connects the microgrid's PCC to the basic network. Just when the head agency is not free, the SES has been stopped and the system operates in the auto-administration mode. The PCC problem should be fuelled by the corresponding string converters in the present situation.

Three plane related Micro converters are built of the force network of a string converter. Each thumbnail has an LC output channel. These Micro converters contribute to a correct matrix compromise string converter output voltage. The focusing controller co-ordinates the string converter's output force and voltage. It is also linked to small converter controllers with bandwidth correspondence with low transfer. The tiny converter's district controller works with the thermal converter's output voltage, for the change of power control between miniature converters.

#### 1. Control of DG Unit Power

The DG-grid integrating string converter can inject manageable active and reactive power into the focal framework for grid-connected activity. To begin with, by utilizing low transmission capacity correspondence connects, the string converter central regulator gets the data of every single micro converter. For example, the data of SoC behind the DG focus unit regulator may collect stage battery banks or DC voltage of the supercapacitors. At that point, the active force reference  $P_{ref}$  and the receptive force reference  $Q_{ref}$  of pre-set capacity of the board processes the string converter is mandated. With the previously mentioned power instrument, the yield force referral of micro converter  $k$  is re-communicated as:

$$p_{ref} = \varepsilon_{p,k} p_{ref}$$

(Equation 6)

$$Q_{ref} = \varepsilon_{q,k} Q_{ref}$$

(Equation 7)

where  $P_{ref,k}$  and  $Q_{ref,k}$  are the reference genuine and responsive force of micro converter  $k$ . In this string converter, the coefficients  $\varepsilon_{p,k}$ , and  $\varepsilon_{q,k}$  represent the yield power proportion of micro converter  $k$ .

The droop control in the string converter focal regulator can be used to obtain a closed loop control of the string converter yield power:

$$\omega_{DG} = \omega^* + Dp \cdot \frac{\omega_{Cut}}{s + \omega_{Cut}} (p_{ref} - p_{DG})$$

(Equation 8)

$$E_{DG} = E^* + (Dq + \frac{k_{iq}}{s}) \cdot \frac{\omega_{Cut}}{s + \omega_{Cut}} \cdot (Q_{ref} - Q_{DG})$$

(Equation 9)

where  $\omega^*$  and  $\omega_{DG}$  are the string converter's apparent and reference angular frequencies. The apparent and reference string converter voltage extents are denoted by  $E^*$  and  $E_{DG}$ , respectively. A Focal regulator estimates the string converter genuine and receptive power as  $P_{DG}$  and  $Q_{DG}$ . The chop intensity of low transmitting data channels is denoted by cut. The power circle regulator coefficients are  $Dp$ ,  $Dq$ , and  $k_{iq}$ . It should be noted that the basic control can guarantee zero consistent state receptive power after a blunder for string converter mesh activity. Because the yield receptive power in islanding activity mode is determined by the PCC load interest, this addition  $k_{iq}$  should be initialized for equal string converters power-sharing when the primary framework is turned off.

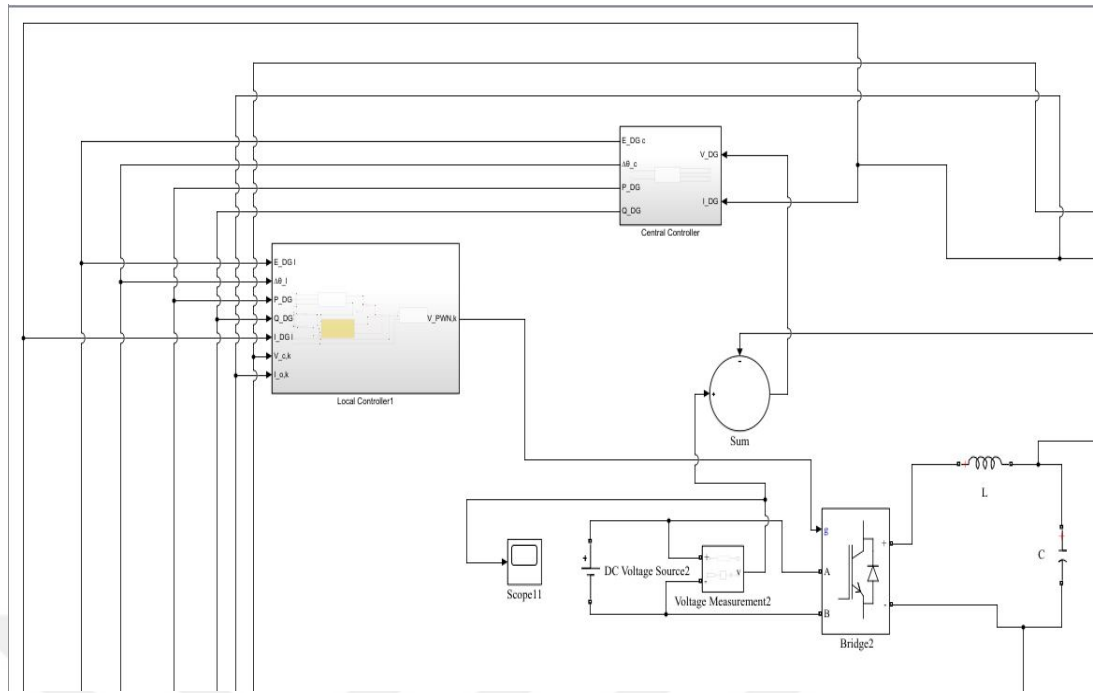

Figure24: A String Converter System's Equivalent Circuit.

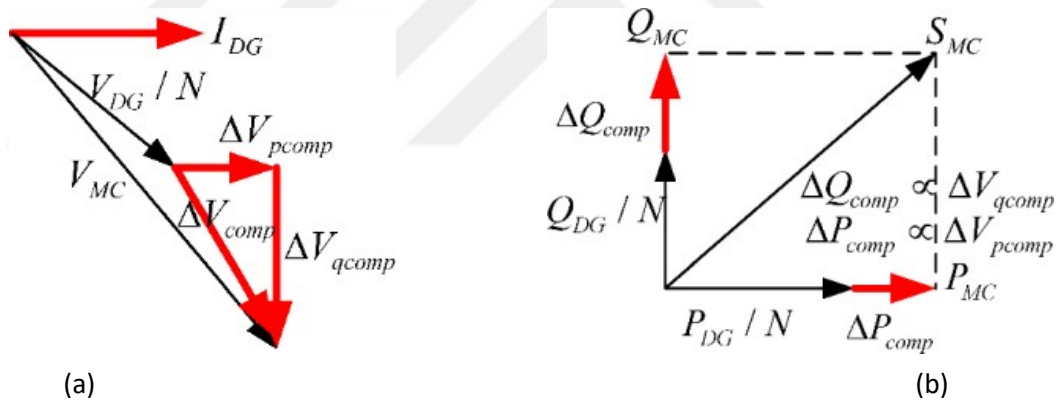

Figure25: Phasor Diagram of a Microconverter.

At the point if the voltage size as well as frequency references are being controlled by the two figures above, the immediate voltage reference  $V_{DG,C}^*$  is gotten utilizing:

$$V_{DG,C}^* = E_{DG} \sin \left( \int \omega_{DG} dt \right)$$

(Equation 10)

It is important to remember that along with the string converter yield voltage as  $V_{DG,C}^*$  it may operate naturally synced with the main grid without use of Phase-Locked-Loops (PLLs). This is similar to the characteristics of "synchronverters."

When  $V_{DG,C}^*$  is obtained, it is modulated using the Sliding DFT (Sliding Discrete Fourier Transform) to obtain  $E_{DG,C}$ , and  $\theta_{vol,c}$ . Also, the  $I_{DG}$  is modulated too, to obtain  $\theta_{cur,c}$ . This happens in the string converter central controller. Every output from the central controller is sent to the local controller of the micro converter.

## 2. Microconverter Local Power Control

With the regulators, the string converter's yield power structure is viably directed. A string converter's yield power is equivalent to the total of the yield forces of all organize micro converters. In any case, the force reference proportion of each micro converter has not been resolved at this point.

Accepting all arrangement micro converters when using a sequence transformer similarly spread the yield force order, the voltage of reference in equation (10) it is possible it is possible partitioned because of arrangement associated micro converter numbers  $N$ . At that point, it is utilized as the reference voltage for all micro converters as:

$$V_{MC,k}^* = V_{DG,L}^*/N$$

(Equation 11)

where  $V_{MC,k}^*$  is the voltage of reference of micro converter  $k$  and  $V_{DG,L}^*$  is the voltage reference of string converter gotten by micro converter local regulators. The strategy for communicating the reference voltage  $V_{DG,C}^*$  derived from focal regulator of the string converter to micro converter neighborhood regulators as  $V_{DG,L}^*$  would be discussed further in the following sub-sections.

Note that the yield power of these micro converters can be distinctive for better power management of a string converter, yet the regulator in (11) can't give this autonomous power guideline work. This restriction is settled by utilizing a power compensator in the micro converter neighborhood regulator, as demonstrated in Fig. 24 what's more, Fig. 25.

To begin, the same string converter circuit is shown in Fig. 24. As shown in the top portion of the figure, the string converter is represented as a voltage regulator, in which the true force stream  $P_{DG}$  is in relation to the stage point distinction between PCC voltages and string converter output as  $\theta_{Vol} - \theta_{PCC}$  and the receptive force stream  $Q_{DG}$  is in relation to the voltage extent contrast as  $E_{DG} - V_{PCC}$ .

A string converter's circuit is made up of a couple of schemes linked voltage sources with LV control. Each micro converter is addressed by two voltage sources,  $V_{DG}/N$  and  $\Delta V_{comp}$ , as shown in the lower part of Fig. 24. When only  $V_{DG}/N$  is working and  $\Delta V_{comp}$  is zero, the genuine and receptive force order is shared by all arrangement micro converters. However, when  $\Delta V_{comp}$  is not zero, this term can be used to effectively change the micro converter yield power as  $\Delta P_{comp}$  and  $\Delta Q_{comp}$ , as required by the force control.

Figure 25 depicts the relationship between microconverter yield power variations and the corresponding voltage term  $\Delta V_{comp}$ . The reference outline is adapted to the string converter line current phasor. When the micro converter voltage is changed, the difference in genuine force  $\Delta P_{comp}$  is in relation to the voltage phasor  $\Delta V_{pcomp}$  in a flat way, and the difference in receptive power  $\Delta Q_{comp}$  is in relation to the voltage phasor  $\Delta V_{qcomp}$  that is 90° slacking of the line current.

The closed-loop local power control of a micro converter  $k$ , as indicated by this relationship, is given as:

$$V_{MC,k}^* = V_{DG,L}^*/N + \Delta V_{pcomp} + \Delta V_{qcomp}$$

(Equation 12)

$$\Delta V_{pcomp} = \left( k_{P,MC} + \frac{k_{i,MC}}{S} \right) (\varepsilon_{p,k} P_{DG} - P_{MC,k}) * \cos(\theta_{cur,L})$$

(Equation 13)

$$\Delta V_{qcomp} = \left( k_{P,MC} + \frac{k_{i,MC}}{S} \right) (\varepsilon_{q,k} Q_{DG} - Q_{MC,k}) * \sin(\theta_{cur,L})$$

(Equation 14)

where  $k_{P,MC}$  is the corresponding increase and  $k_{i,MC}$  is the fundamental addition of the PI controller for autonomous micro converter nearby genuine and responsive

force guideline and  $\theta_{cur,L}$  is stage point of the string converter line current distinguished by micro converter neighborhood regulator.

At the point when the voltage reference for micro converter  $k$  is resolved, as well as surely knew twofold circle voltage regulator as demonstrated in [Equation 10] is chosen for quick micro converter voltage following. The external control circle is given as:

$$I_{ref,k}^* = G_{outer}(s) \cdot (V_{MC,k}^* - V_{C,k}) = \left( k_p + \frac{2k_i\omega_c s}{s^2 + 2\omega_c s + \omega^{*2}} \right) \cdot (V_{MC,k}^* - V_{C,k})$$

(Equation 15)

Where  $V_{C,k}$  is the deliberate micro converter voltage of LC filter capacitor,  $k_p$  is the relative addition,  $k_i$  is the semi-resonant regulator increase, and  $\omega_c$  is the quasi-resonant regulator cut-off frequency.

The internal control circle for following the yield current of a micro converter is given as:

$$V_{PWM,k}^* = G_{inner}(s) \cdot (I_{ref,k}^* - I_{o,k}^*) = k_{inner} \cdot (I_{ref,k}^* - I_{o,k}^*)$$

(Equation 16)

Where  $I_{ref,k}^*$  is the reference current of the inner current control loop  $I_{o,k}^*$  is the micro converter's output current  $k_{inner}$  is the inner loop proportional gain, and  $V_{PWM,k}^*$  is the reference voltage of the H-bridge-based micro converter  $k$ .

### 3. Coordination of String Converters and Microconverters

The string converter data, including the string converter genuine and receptive power ( $P_{DG}$  and  $Q_{DG}$ ), the yield power proportion reference ( $\varepsilon_{p,k}$  and  $\varepsilon_{q,k}$ ) of each micro converter, and the momentary reference voltage ( $V_{DG,C}^*$ ), will be sent from the string converter central regulator to the micro converter nearby regulators in the previous segment. It should be noted that the momentary voltage reference ( $V_{DG,C}^*$ ) is an alternating current value. As a result, sending this data via standard low transfer speed correspondence frameworks is difficult.

To overcome this limitation, a unique customized methodology based on the basic string converter line current as a synchronizer is presented, as shown in Fig. 26.

To begin, the magnitude and phase angle of the reference voltage,  $V_{DG,C}^*$  and the phase angle of line current  $I_{DG,C}$  are acquired using the sliding DFT at the string-converter central regulator as  $E_{DG,C}$ ,  $\theta_{Vol,C}$  and  $\theta_{Cur,C}$ , individually. The sliding DFT in this case is a rapid estimation plot that may acquire phase angle and extent of signs at key and symphonious frequencies using just tested data from one key cycle.

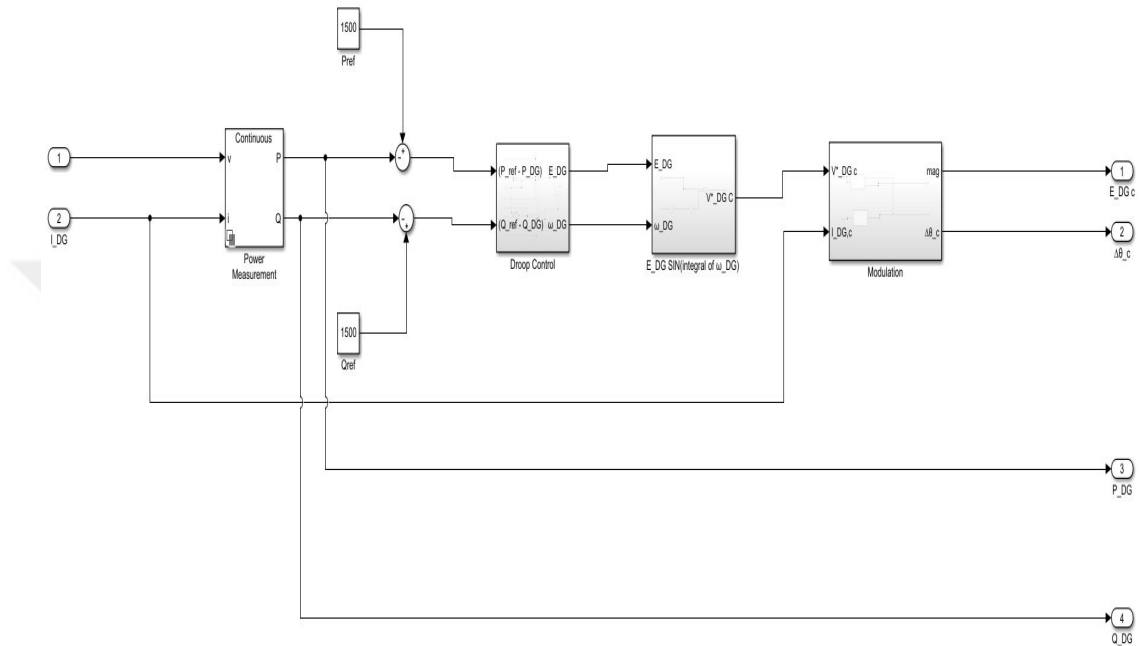

Figure26: Central Controller of Hybrid Microgrid

The magnificence of reference voltage  $E_{DG,C}$  is DC for constant state reference voltage. Furthermore, it has been observed that the power guideline applying hang control has modest features. Appropriately, the difference between voltage and current stage point  $\Delta\theta_C = \theta_{Vol,C} - \theta_{Cur,C}$  is also a DC quantity for simple scope inquiry. This means that  $\Delta\theta_C$ 's unique response is mild, and it can only alter in a small range in a few of exchanging cycles. In this case, the string converter central regulator can send these two DC segments  $E_{DG,C}$ , and  $\Delta\theta_C$  to the micro converter neighborhood regulators through a low data transfer correspondence. It is vital to note that identifying the reference voltage and line current stage point using sliding DFT is only for synchronizing a central regulator and a local regulator using low transfer speed interchanges. It is not the same as matrix synchronization using PLLs.

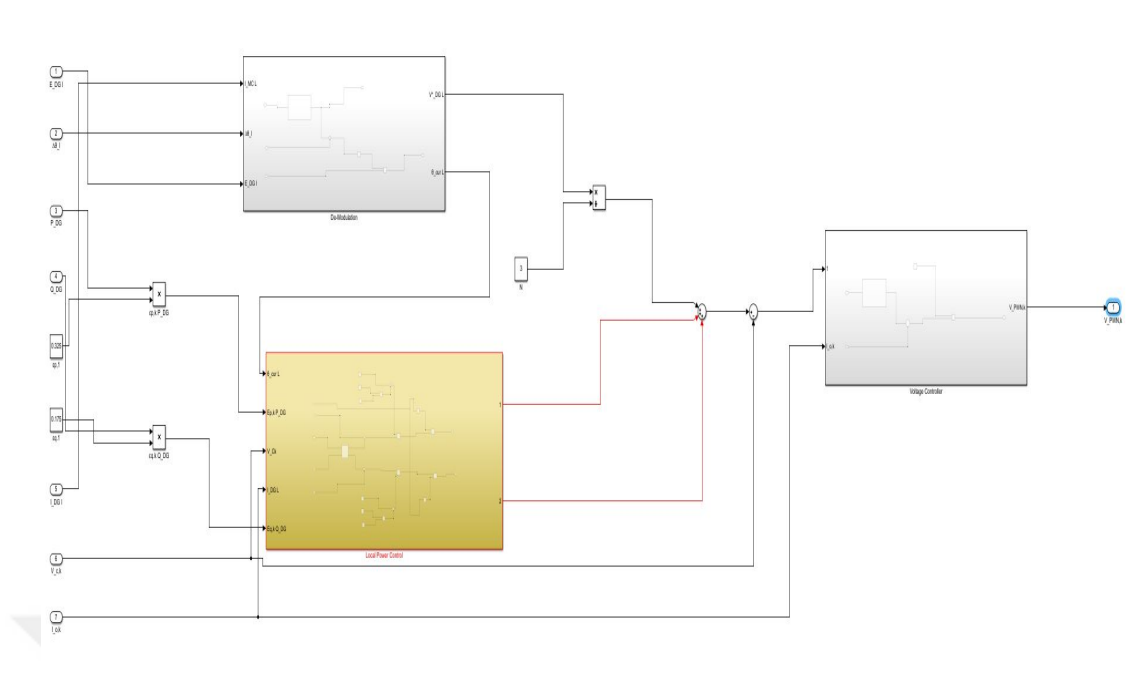

Figure27: Local Controller of the Hybrid Microgrid.

Because of the component of a chain-connected design, the central regulator and the micro converter neighborhood regulator measure a similar string converter current as defined by  $I_{DG}$ . As a result of this discovery, the received signals  $E_{DG,L}$  and  $\Delta\theta_L$  at micro converter neighborhood regulator can be utilized to reproduce the prompt voltage of reference as:

$$V_{DG,L}^* = E_{DG,L} \sin(\Delta\theta_L + \theta_{Cur,L})$$

(Equation 17)

where  $V_{DG,L}^*$  is the string converter rapid reference voltage acquired by the micro converter nearby regulator,  $E_{DG,L}$ , and  $\Delta\theta_L$  are the reference voltage extent and the stage point distinction got by the micro converter. Likewise,  $\Delta\theta_{Cur,L}$  is the current stage point of the string converter line acquired by micro converter neighborhood estimations. At that point, the prompt reference voltage for a micro converter can be gotten as demonstrated in (17). At the point when both the focal regulator control conspire and the neighborhood regulator control plot are presented, the string converter framework's comprehensive supervision chart may be found in Fig. 27.

Table 1: Parameters of the Simulated & Experimental System

<b>Circuit Parameter</b>	<b>Value</b>
Grid voltage	Single-phase 120V/50Hz
Micro converter numbers in a string converter	4
Micro converter LC filter	$L_1=1\text{mH}$ $R_1=8\text{ m}\Omega$ ; $C_f=60\mu\text{F}$ ;
DC link voltage	135V
Switching frequency	20kHz
PCC RL load	$R=10\Omega$ $L=25\text{mH}$
Feeder impedance	String Converter1: $R=0.2\Omega$ , $L=1.7\text{mH}$
	String Converter2: $R=0.2\Omega$ , $L=2.0\text{mH}$
<b>Central Controller parameter</b>	<b>Value</b>
Real power droop coefficient	$D_p=1/550$
Reactive power droop coefficient	$D_q = 1/220$ $k_{iq} = 1/45$
Sampling frequency for SDFT	20kHz
<b>Local Controller parameter</b>	<b>Value</b>
Sampling frequency for SDFT	20kHz
power control coefficient	$k_{p,MC} = 1/100$ , $k_{i,MC} = 1/70$
Outer loop control	$k_p = 0.1$ , $k_i = 20$ , $\omega_c = 5\text{rad/s}$
Inner loop control	$k_{inner} = 20$

## VIII. PROPOSED MICROGRID SIMULATION

This chapter includes reenacted and experimental results to validate the demonstration of my suggested microgrid system. The framework's boundaries are shown in Table 2 above. In Fig. 28, a trial model with two string converters is shown, with each micro converter created using Infineon IGBTs. The central and neighborhood control plans are both built using TI TMS320F28335 DSP sheets. The DC connections are powered by diode rectifiers, with a separation transformer installed at the front end.

The experiment was carried out using MATLAB/SIMULINK. The microgrid system was set up as indicated in figure 29.

### A. Grid-Tied Operation Simulation

To begin, a string converter's network-connected activity is validated. The strong execution of the framework is shown in Fig. 30 when the genuine and receptive power references are set to 1500W and 1500Var at 1.0 sec. For simplicity, the micro converters' DC connections are linked to four disengaged DC sources at 135V. Furthermore, the low transmission capacity correspondence architecture is replicated by a zero-request hold with a testing frequency of just 300Hz.

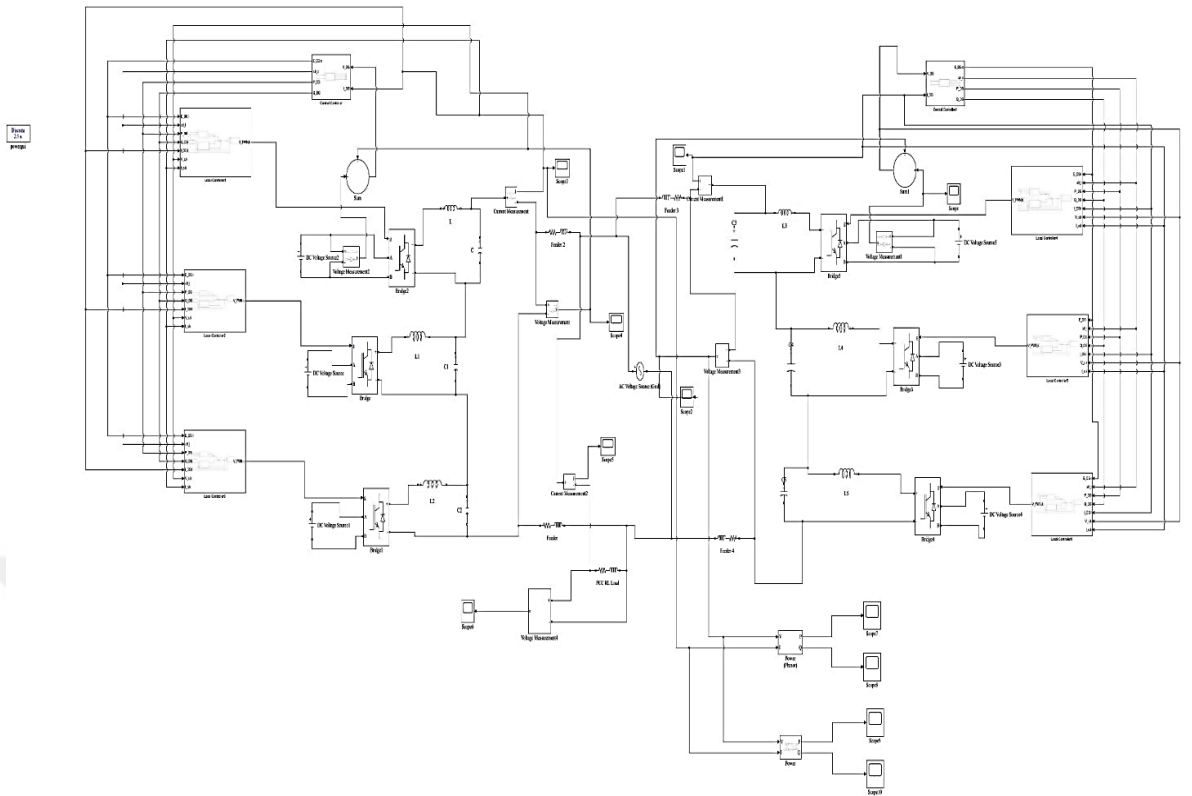

Figure29: Grid-tied Simulink Model.

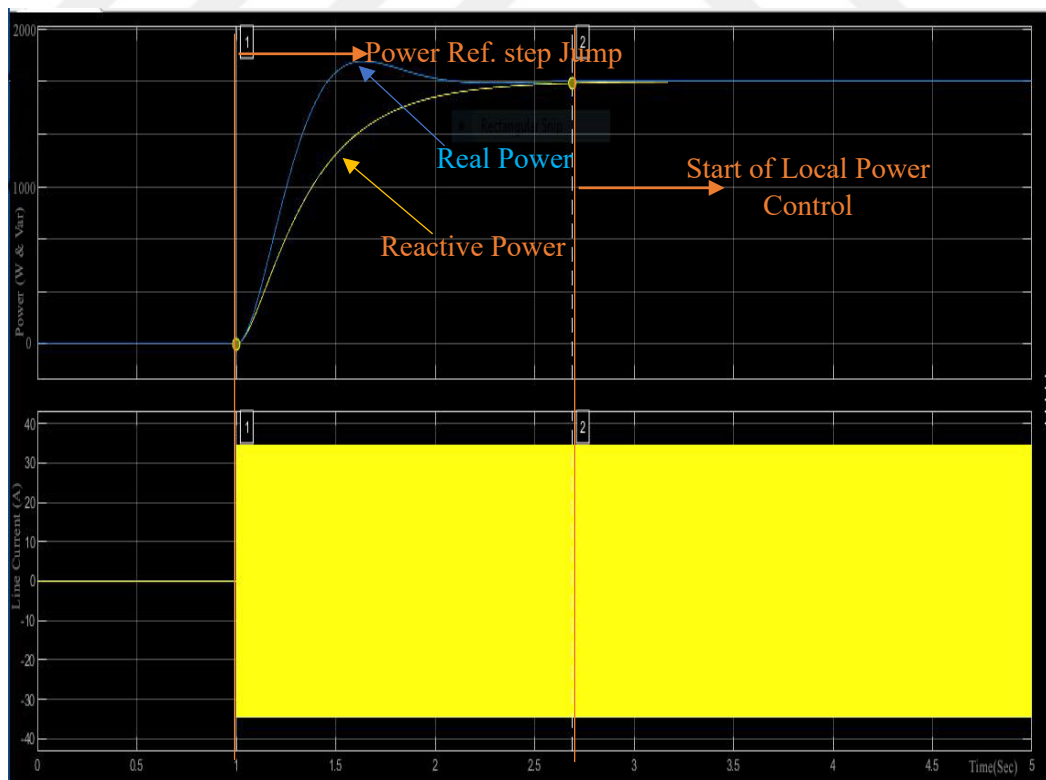

Figure30: Power Control Study of String Converters (Grid-Tied).

As with the display of a standard Droop control-based DG unit, it can be observed in Fig. 30 that the true power reaction is rapid while the receptive power dynamic reaction is fairly languid. The corresponding string converter current is shown in the lower part of the picture. It should be noted that there are certain improved procedures, such as the adaptable virtual impedance control and the feed-forward voltage control, to increase the receptive power after execution.

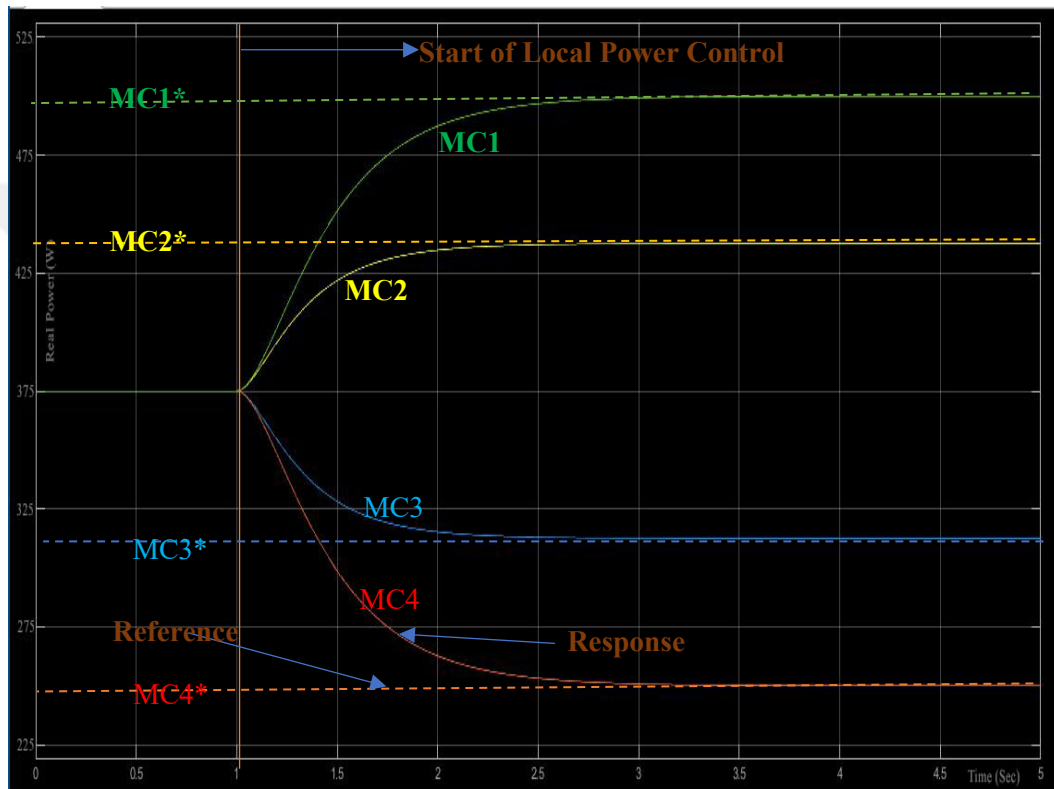

Figure31: Microconverters Real (Active) Power Control Performance (Grid-Tied).

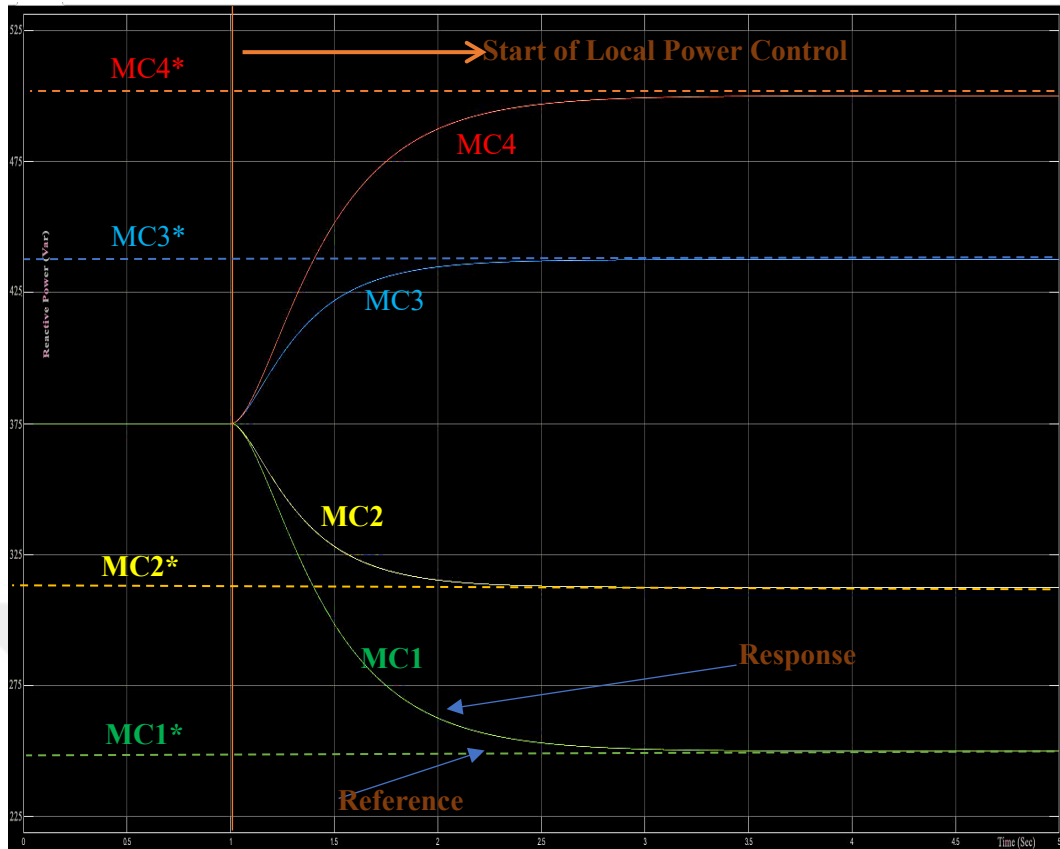

Figure32: Microconverters Reactive Power Control Performance (Grid-Tied).

The exhibition of each micro converter is likewise explored. Toward the start of the experiment, the micro converter nearby Power control isn't initiated and 4 Micro converters have a similar voltage reference. As needs are, they similarly share the power order as demonstrated in Fig. 31 and Fig. 32 At the point when the power control order proportion for micro converters are set to  $\varepsilon_{p,1}=0.325$ ,  $\varepsilon_{p,2}=0.275$ ,  $\varepsilon_{p,3}=0.225$ , and  $\varepsilon_{p,4}=0.175$ ,  $\varepsilon_{q,1}=0.175$ ,  $\varepsilon_{q,2}=0.225$ ,  $\varepsilon_{q,3}=0.275$ , and  $\varepsilon_{q,3}=0.325$  at 2.689 sec, it very well may be seen that all micro converter yield power gradually arrives at the order esteem at the consistent state.

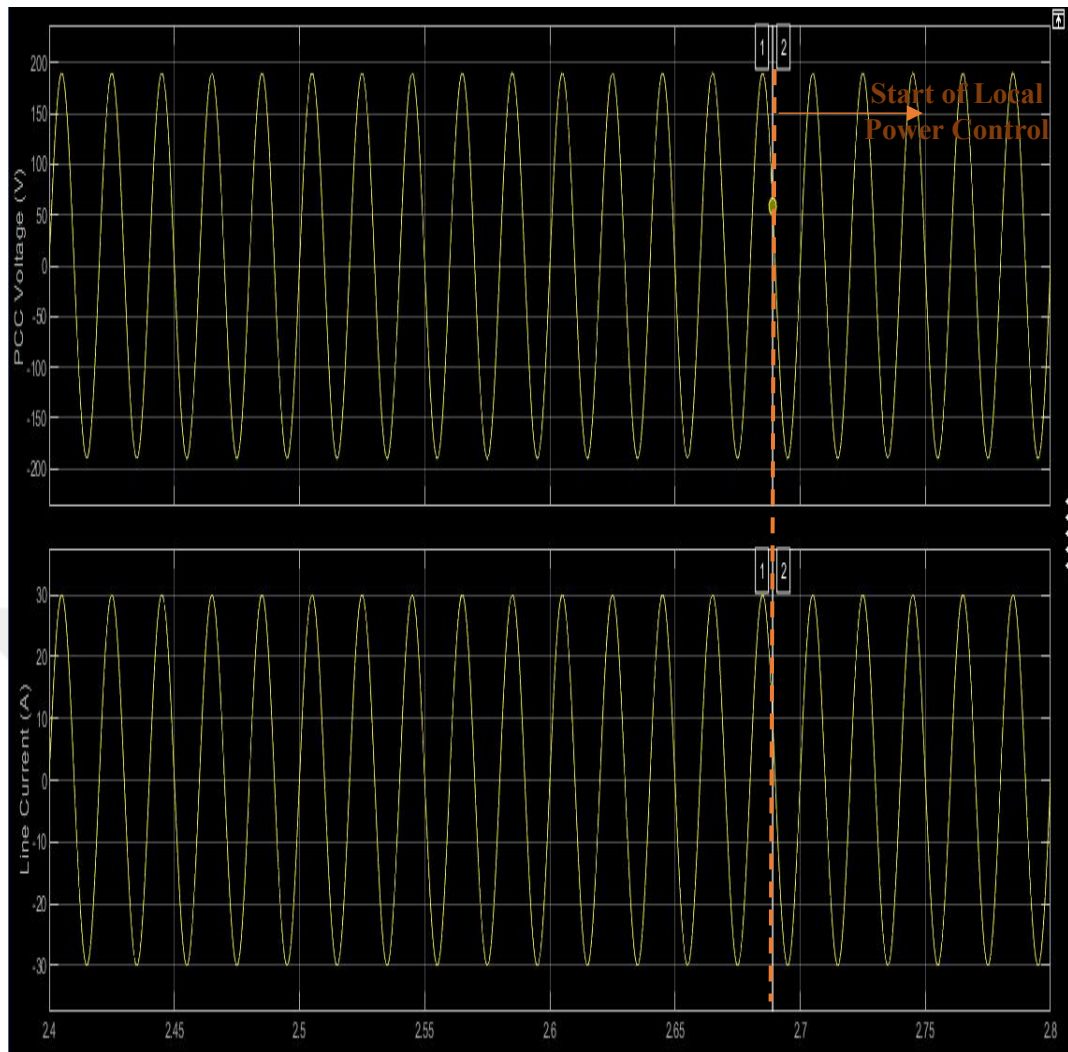

Figure33: PCC Voltage and String Converter Line Current during the Transition of Local Power Regulation. (Grid-Tied)

At the point when the local power control is carried out in the micro converter nearby regulator, the line current waveform of the string converter appears in Fig. 33. It very well may be seen that there is no undeniable overshoot during the beginning of the local power control.

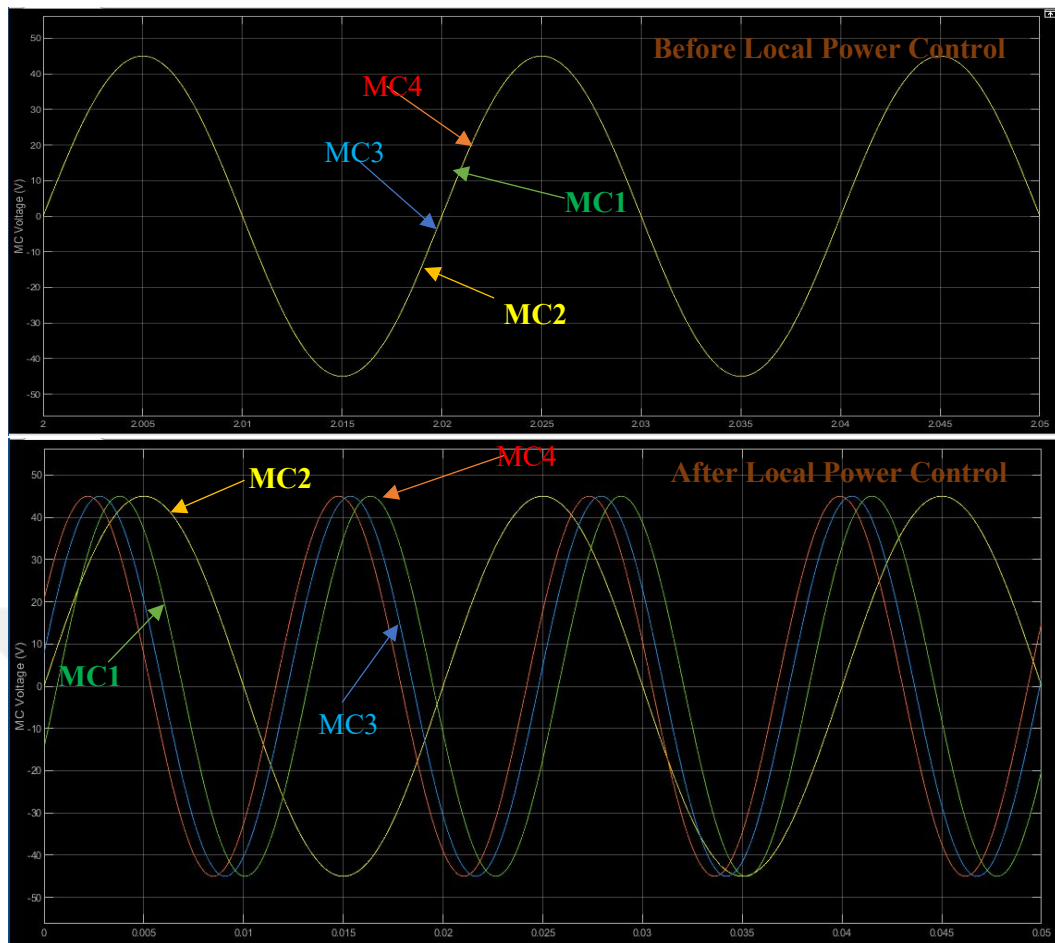

Figure34: Microconverter Voltage Before and After Local Power Control. (Grid-Tied)

The miniature converter voltage waveforms when the usage of the proposed miniature converter close forcibly control shows up in Fig. 34. Without using the proposed nearby force control strategy, the voltage waveforms of four miniature converters are essentially something comparative. Exactly when the yield force of four miniature converters are not comparable on account of the establishment of close forcibly control, the AC voltage waveforms also have clear differences.

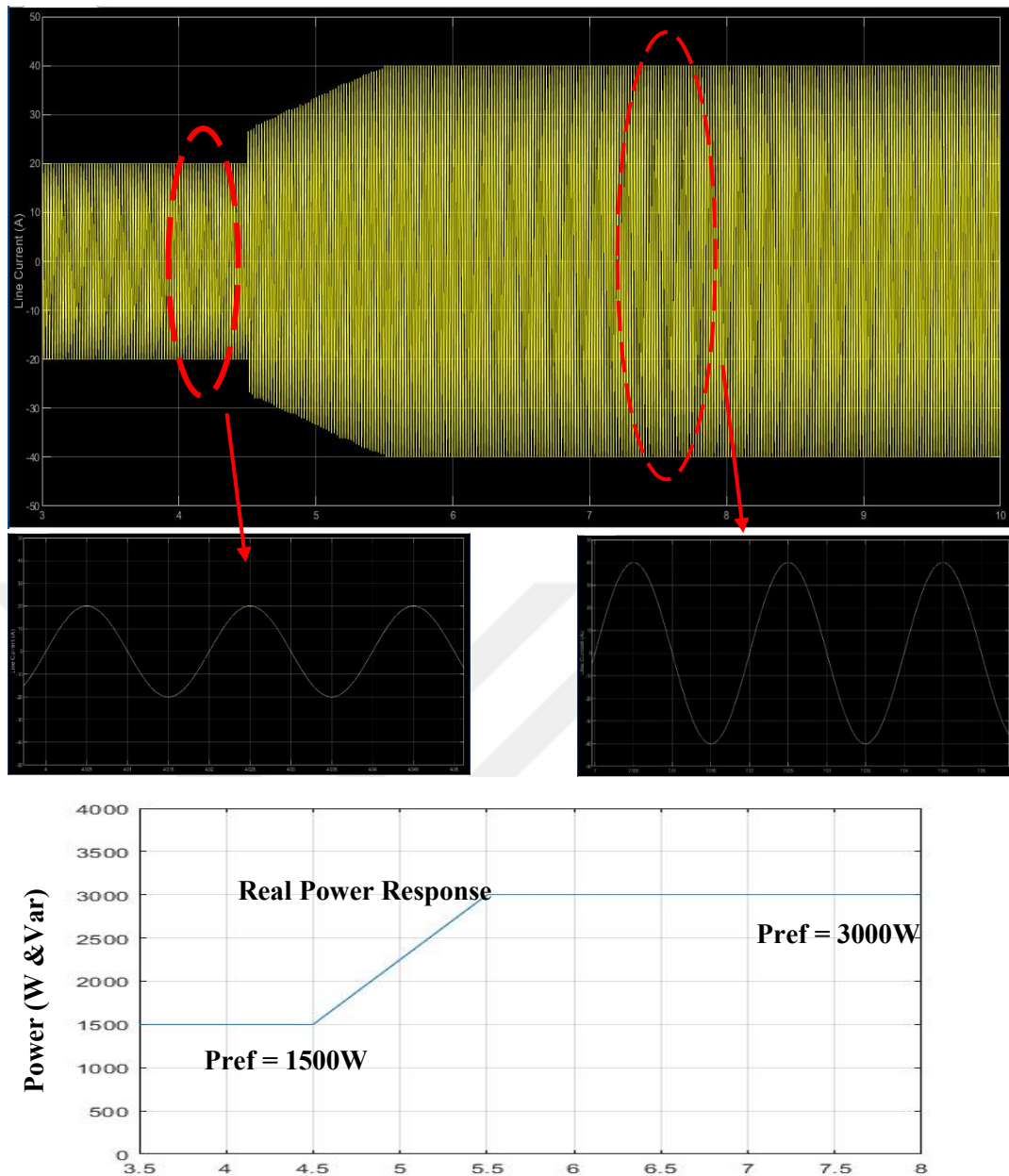

Figure35: String Converter Dynamic Performance. (Grid-Tied)

To display that the proposed system is at this point convincing in any occasion when the miniature converter DC source voltage has a couple of assortments, another reenactment was coordinated as shown from Fig.35. to Fig. 39. In this test, microconverter1 and microconverter2 DC rails are related with supercapacitors (1F), while other miniature converters are related with fixed voltage DC sources. The string converter yield power has an incline increase from 1500W to 3000W at 4.5 sec. The line current and the string converter yield power response in Fig. 35 show that the structure can decisively follow the force reference and the line current is reliably sinusoidal when the transient.

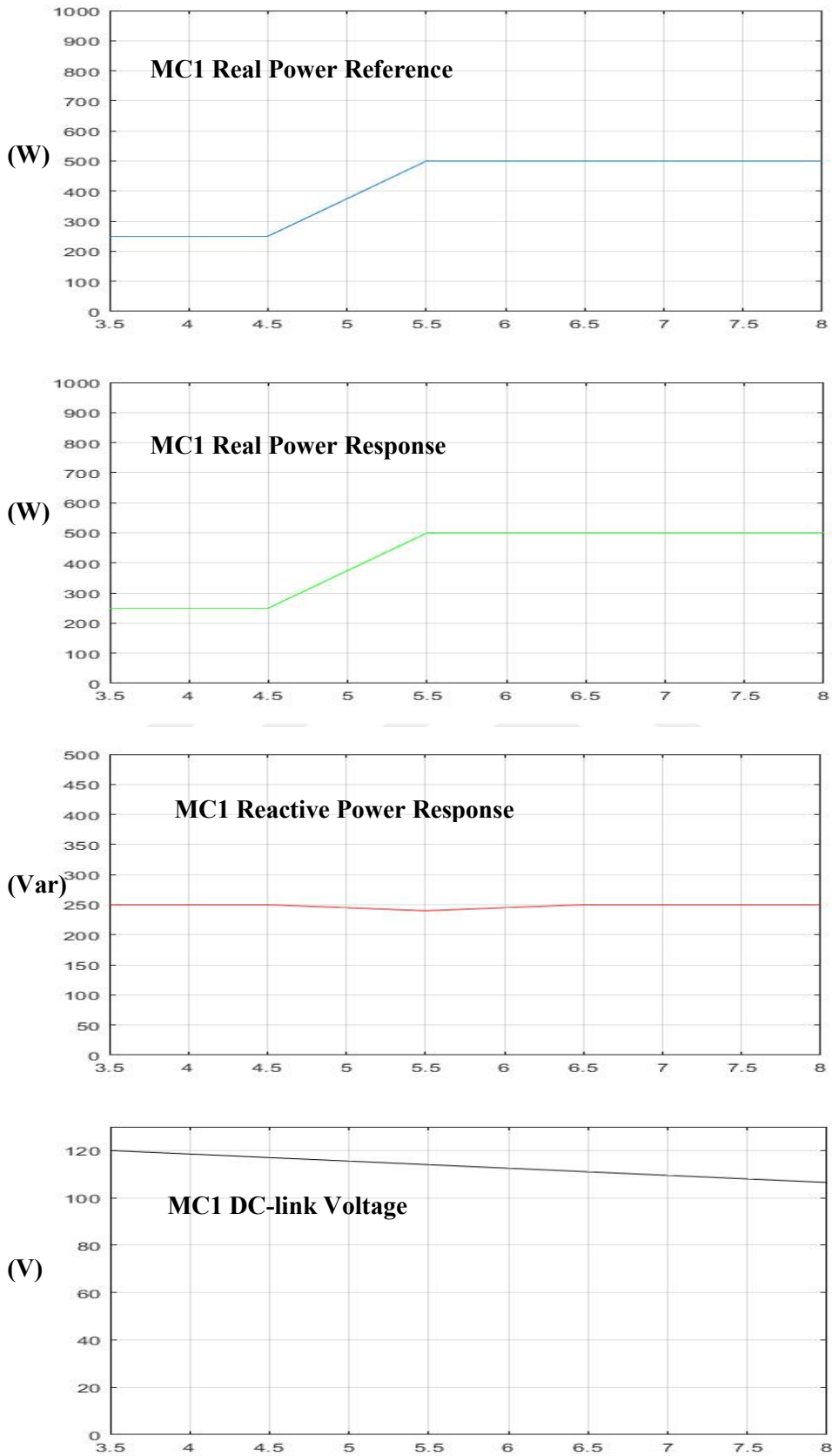

Figure36: Microconverter1 Dynamic Performance. (Grid-Tied; DC-link Connected to Supercapacitor)

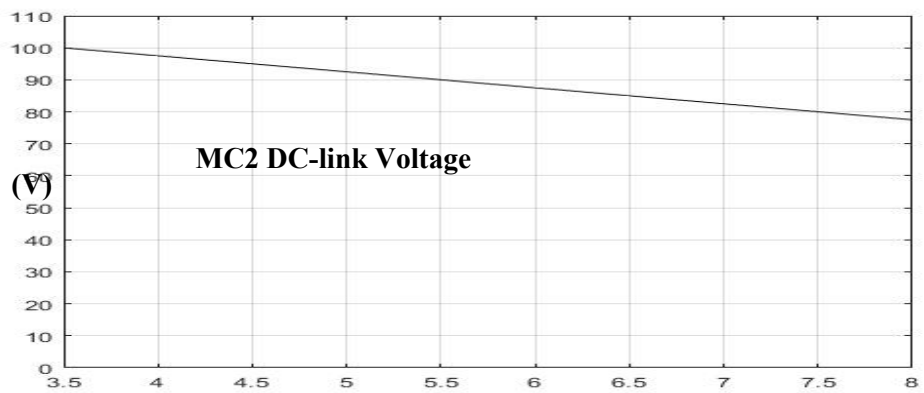
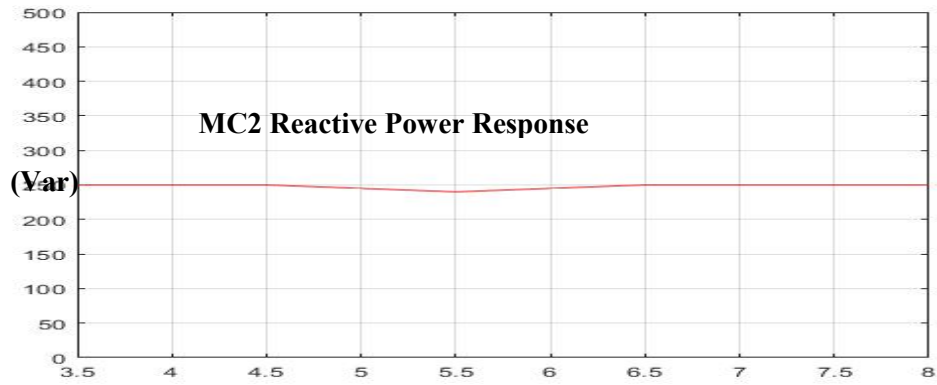
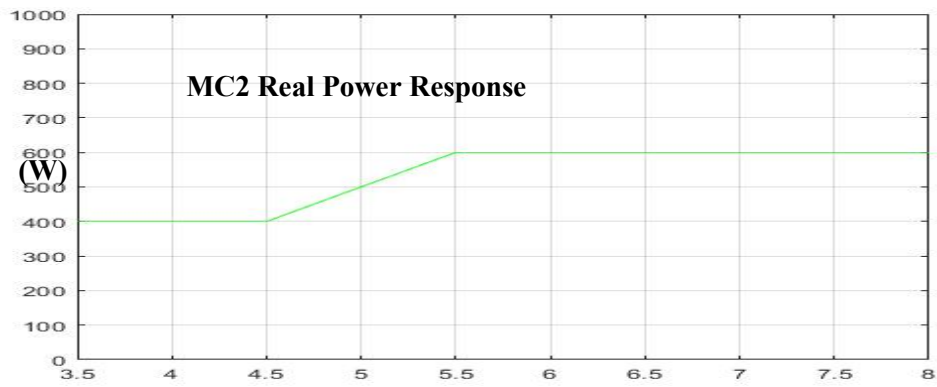
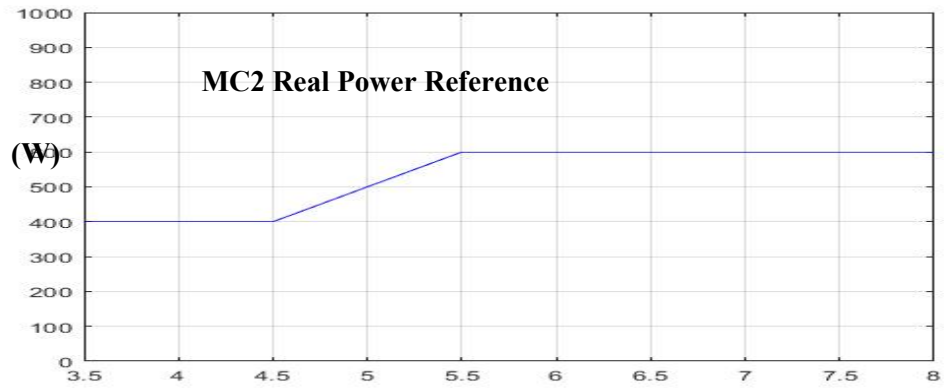

Figure37: Microconverter2 Dynamic Performance. (Grid-Tied; DC-link Connected to Supercapacitor)

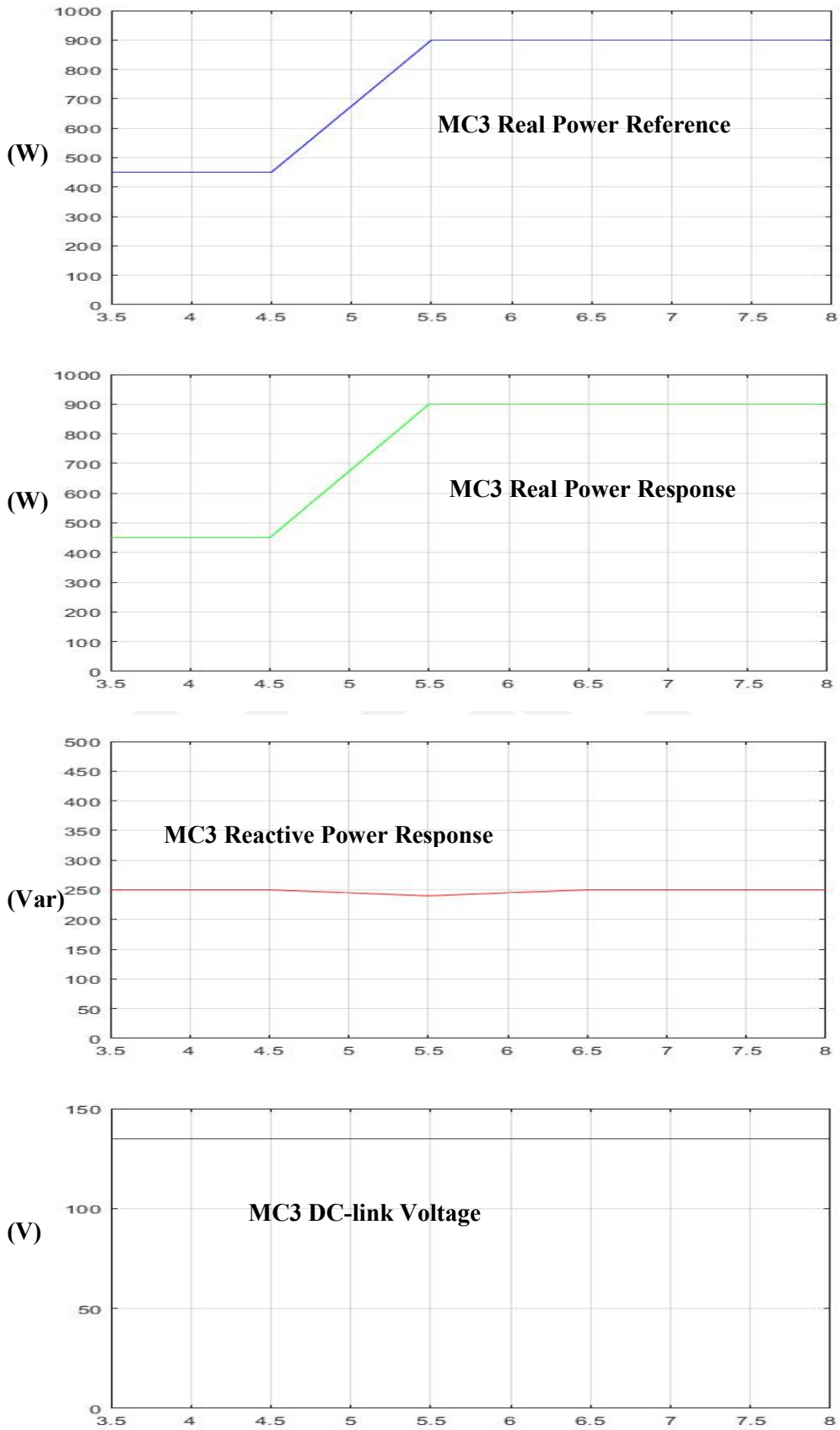

Figure38: Microconverter3 Dynamic Performance. (Grid-Tied; DC-link Connected to Supercapacitor)

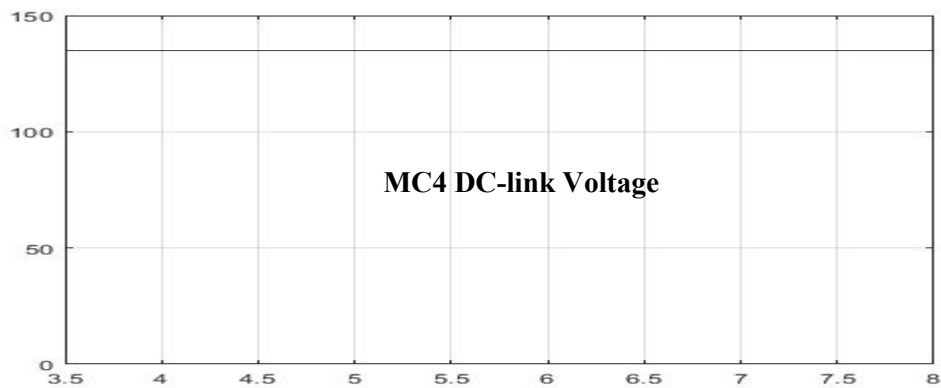
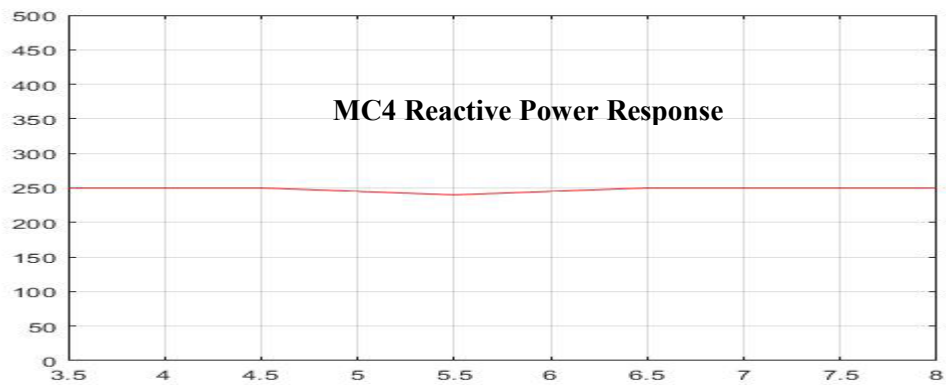
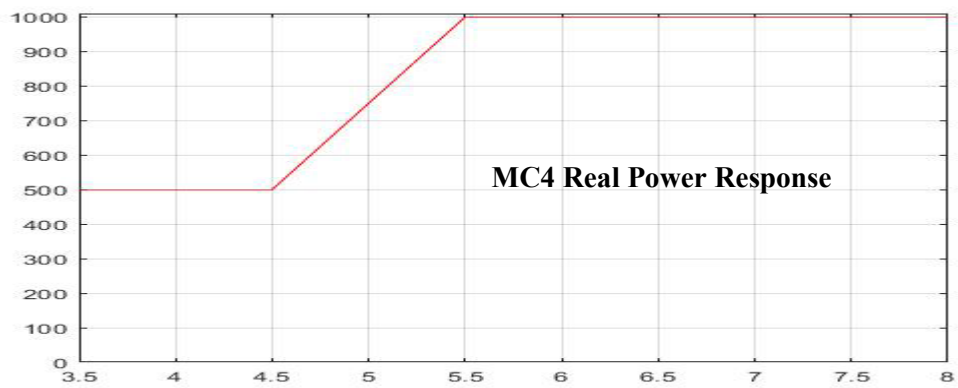
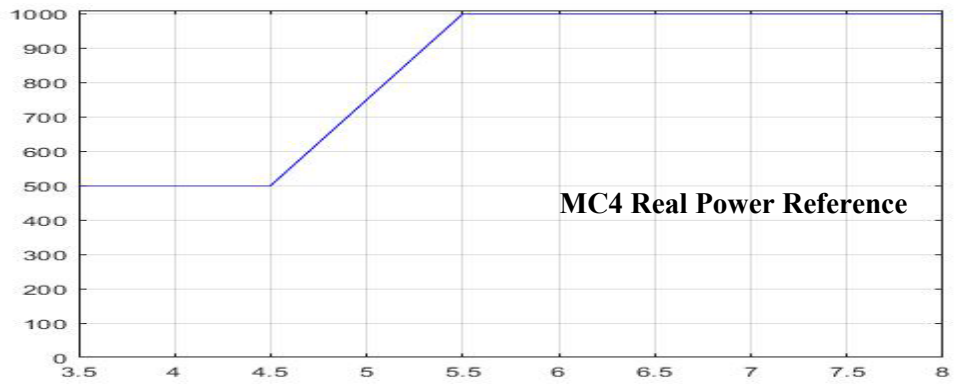

Figure39: Microconverter4 Dynamic Performance. (Grid-Tied; DC-link Connected to Supercapacitor)

Moreover, the ordered execution of each miniature converter in this association shows up from Fig. 36 to Fig. 39. As the DC associations of microconverter1 and microconverter2 are related with supercapacitor banks, it will in general be seen from the base channels of Fig. 36 and Fig. 37 that the DC interface voltage of microconverter1 plunges from 120V to 107.5V and the DC associate voltage of microconverter2 plunges from 100V to 77.5V. For sure, even with some DC voltage assortments, the microconverter1 and microconverter2 yield authentic force as exhibited in the resulting channel has a definite after of reference in the primary channel.

The flexible force the executives designs through obtain change can be applied to the structure to get suitable organization of DC-associate voltage. Regardless, in this structure, we intentionally conveyed confounded DC voltage assortments to check the rightness of the proposed power control and Power improvement procedure in unpleasant conditions.

## **B. Islanding Operation Simulation**

Right when the essential grid is off, equivalent string converters can give incessant power to PCC loads. The islanding action of a crossbreed microgrid with two equivalent related string converters at a comparable power rating is moreover examined.

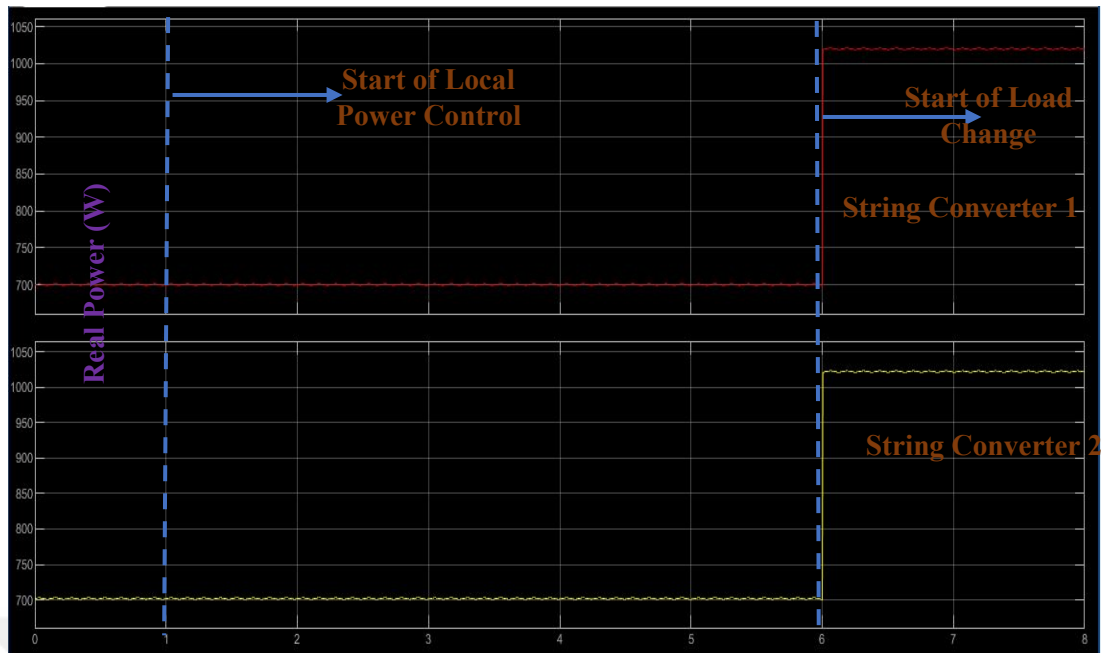

Figure40: Two-String Converters Real Power-Sharing Performance (Islanding).

Fig. 40 and Fig. 42 show the force control of two string converters. The structure has a PCC load step change at 6.0 sec. From the long-timescale waveforms, it might be seen that equivalent string converters also share PCC load interest at both the reliable state and the transient. In light of the effect of conflicting string converter feeder impedance, there is around 20V<sub>ar</sub> open power splitting missteps between string converter1 and string converter2.

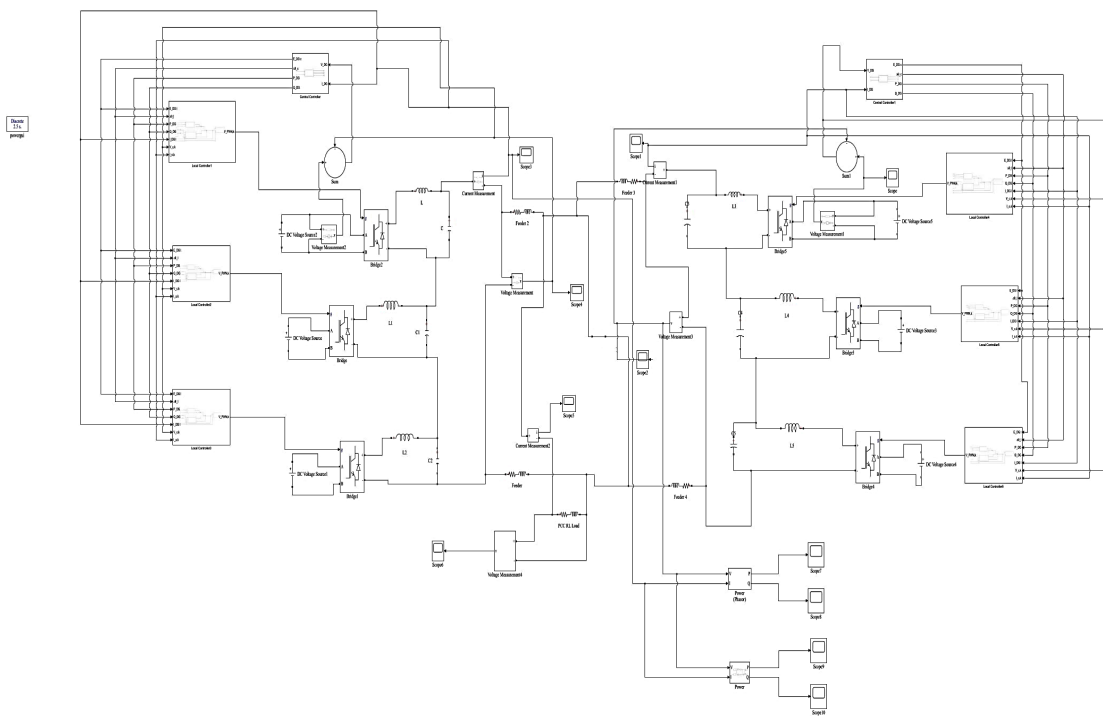

Figure41: Islanding Simulink Model of Hybrid Microgrid.

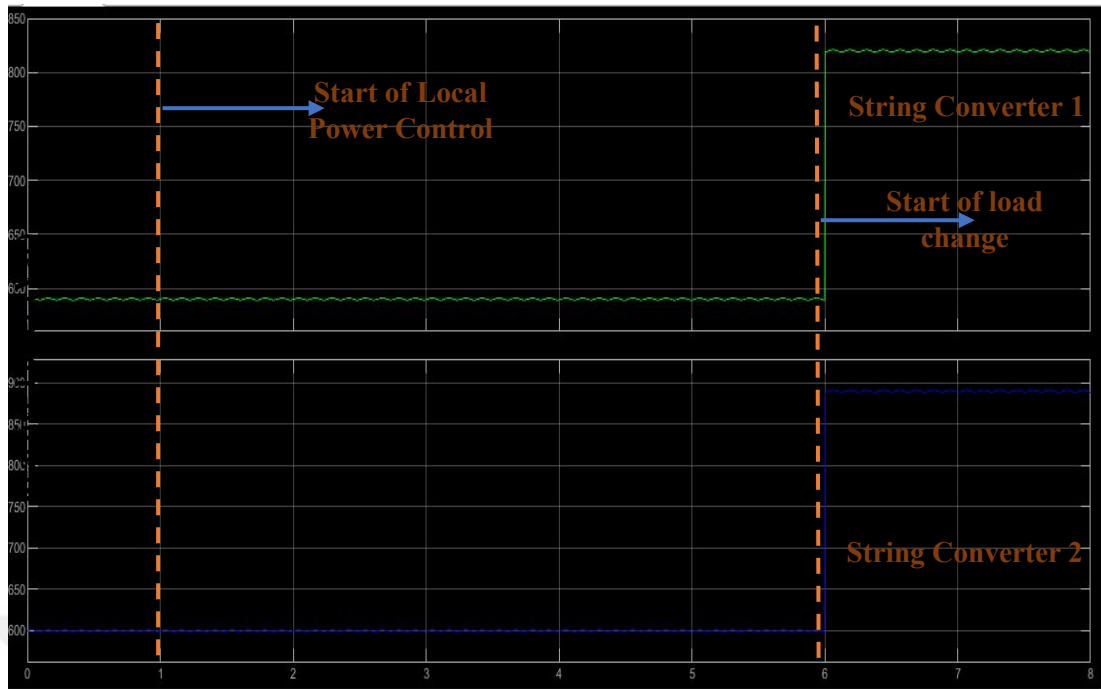

Figure42: Two-String Converters Reactive Power Sharing Performance (Islanding).

Fig. 43 shows the current of two string converters and the PCC voltage degree. As illustrated, the PCC voltage size has around 1 V dive after the load step jump. The zoom-in waveform in the lower some portion of the figure obviously shows that equivalent string converters have similar line current in both the steady state and the transient during load step change.

The point-by-point power control execution of smaller than expected converters in string converter1 is moreover given in Fig. 44 and Fig. 45. In this test, the proposed small scale converter area power control procedure is incited in 1.0 sec and the power reference extents of the smaller than normal converters in string converter-1 are  $\varepsilon_{p,1}=0.325$ ,  $\varepsilon_{p,2}=0.275$ ,  $\varepsilon_{p,3}=0.225$ ,  $\varepsilon_{p,4}=0.175$ ,  $\varepsilon_{q,1}=0.175$ ,  $\varepsilon_{q,2}=0.225$ ,  $\varepsilon_{q,3}=0.275$ , and  $\varepsilon_{q,4}=0.325$ . In like way, the yield power rapidly buoys to new characteristics after 1 sec. Right when the PCC load has a phase change at 6.0 sec, every small-scale converter yield power in like manner increases right away.

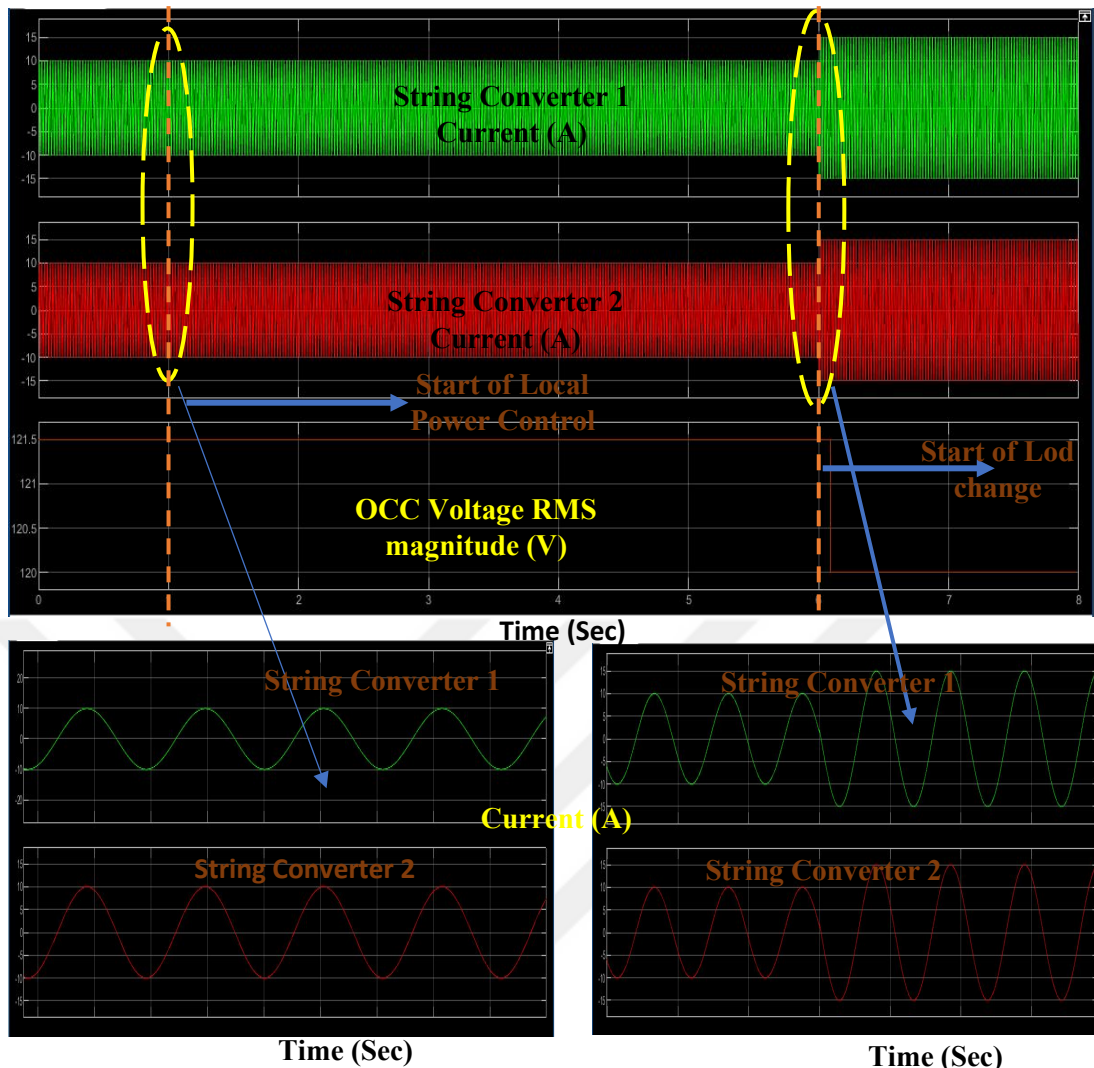

Figure43: Two String Converters Line Current and PCC Voltage Magnitude (Islanding).

It is entrancing to find though the yield power of every little converter changes according to the PCC load demand assortments, the yield power extent for each converter is fixed regardless, during PCC load transient as exhibited in Fig. 46 and Fig. 47.

To also show the display of the islanding structure, the voltage waveform of smaller than expected converters in string converter1 is moreover gotten in Fig. 48. It might be seen that before 1.0 sec, four smaller than normal converters have near voltage waveforms. Right when the power orders for scaled down converters are not same, the voltages of smaller than usual converters are moreover exceptional in light of the use of power rule term (7) in the close by controller.

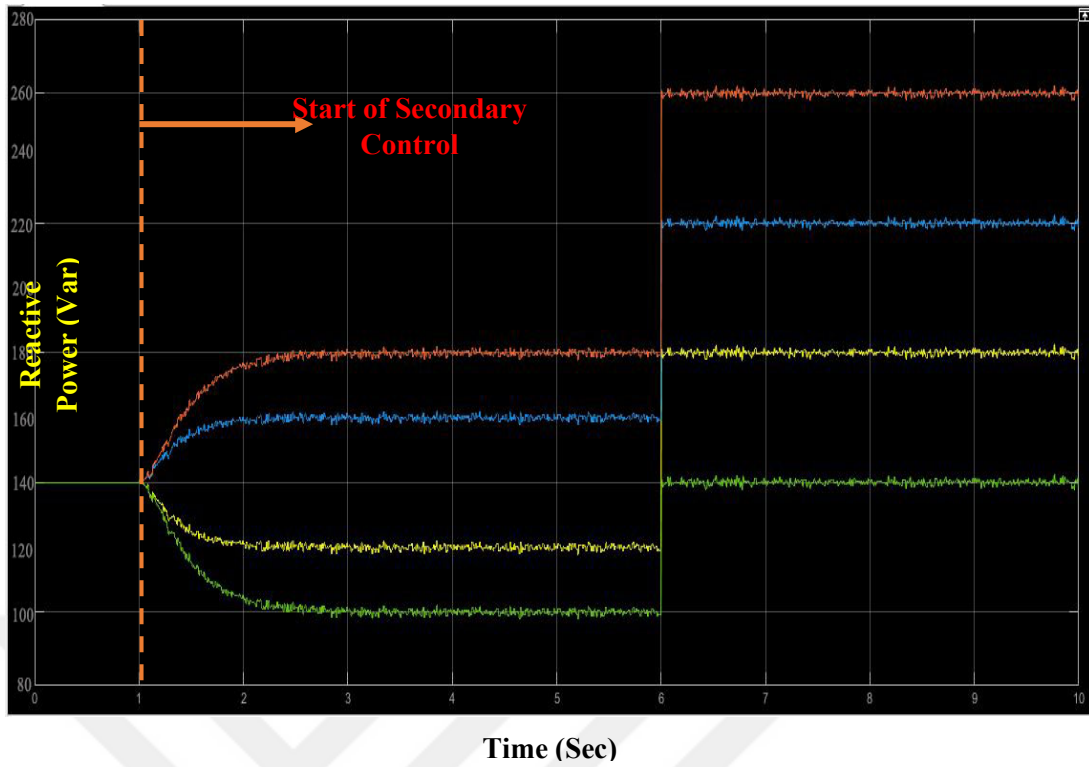

Figure44: Microconverters Reactive Power Control Performance (String Converter1; Islanding).

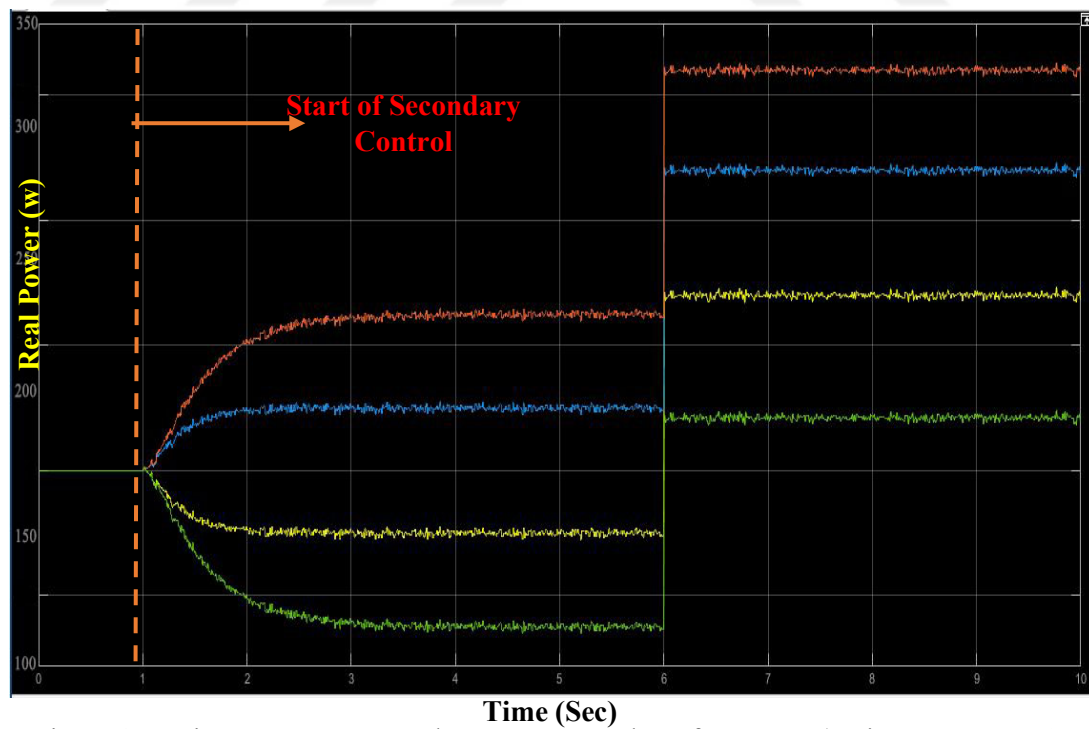

Figure45: Microconverters Real Power Control Performance (String Converter1; Islanding).

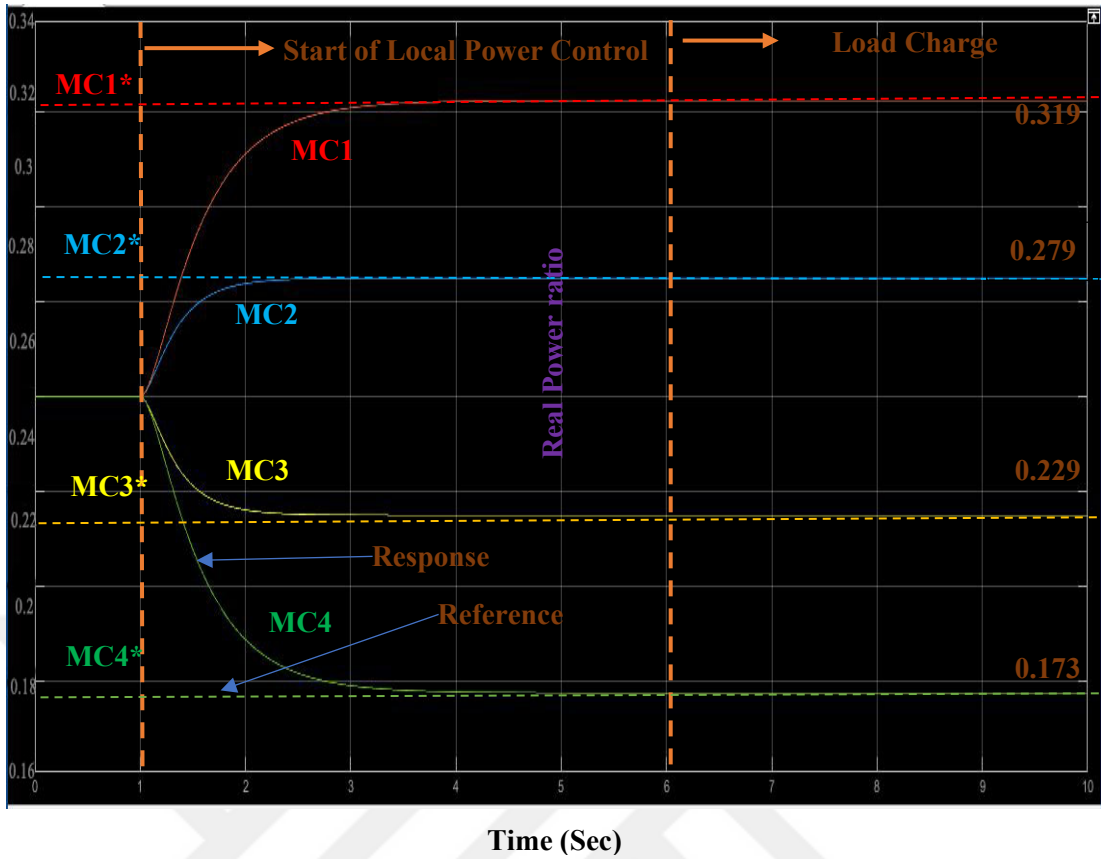

Figure46: Microconverters Real Power Ratio (String Converter1; Islanding).

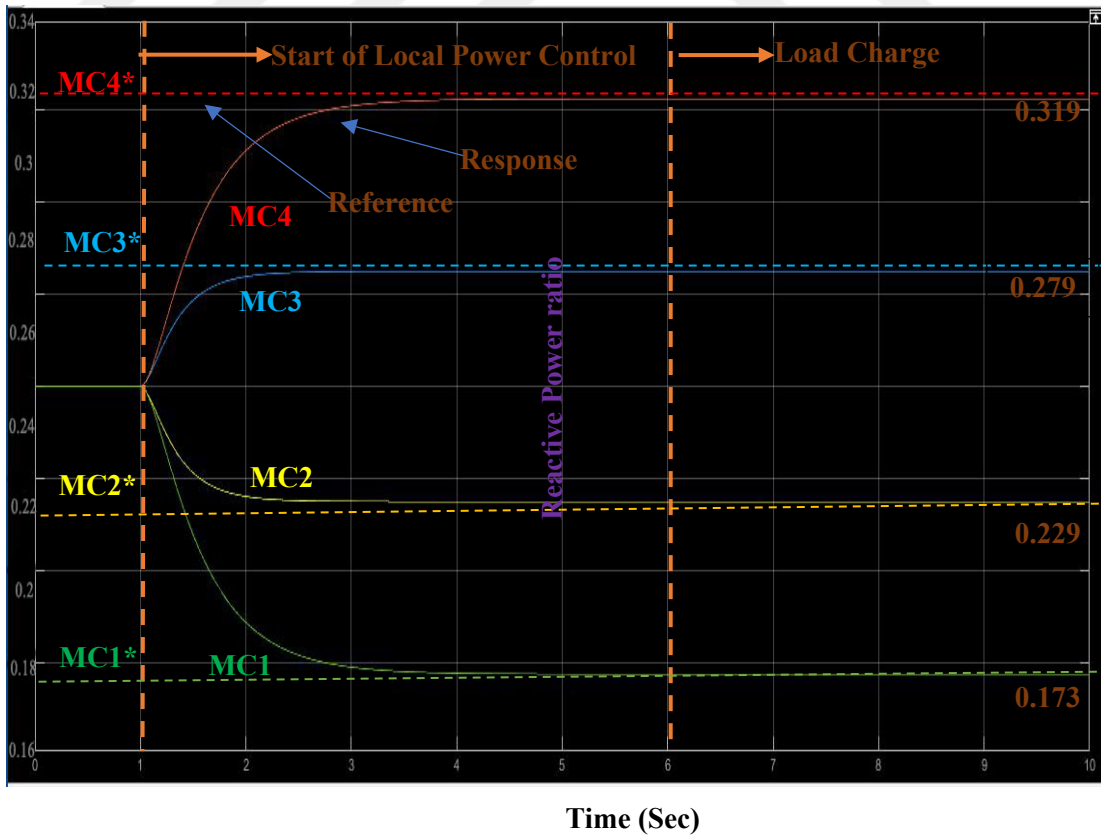

Figure47: Microconverters Reactive Power Ratio (String converter1; Islanding).

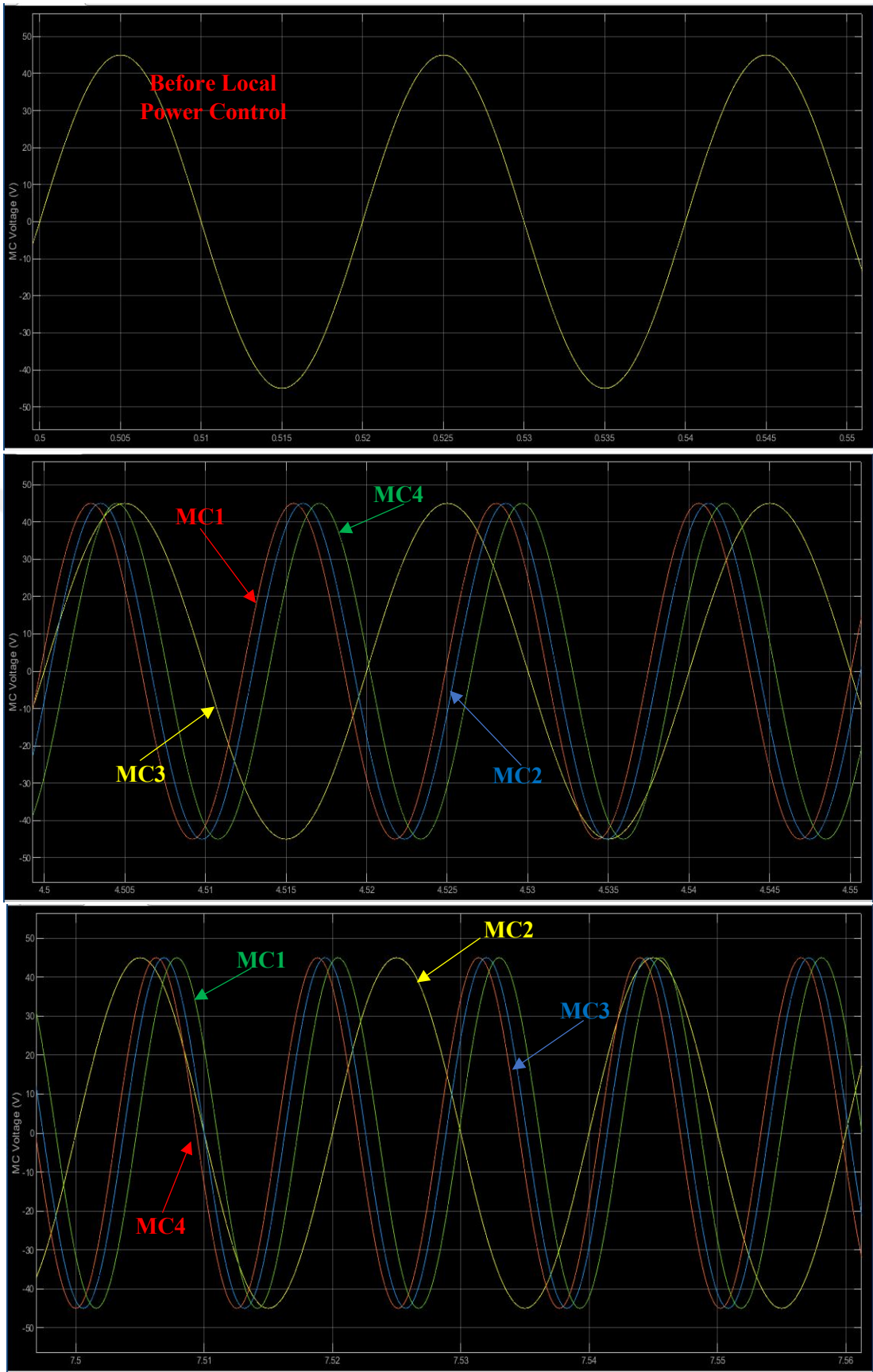

Figure48: Microconverters Voltage Waveforms in Various Situations (String Converter1; Islanding).

## IX. CONCLUSION

To have better power control of passed on energy resources based microgrid, another hybrid microgrid game plan with an equivalent and course of action related LV little converters is proposed. In this, several game plans related small-scale converters structure a string converter, and the power splitting between equivalent string converters is recognized by using hang control. By then, the controllable power scattering among game plan related smaller than normal converters are refined by a direct feed-forward voltage compensator. To feasibly work with the power splitting between equivalent string converters and the power demand redistribution among course of action scaled down converters, a low information transmission correspondence structure using the critical piece of string converter line current as a synchronizer is moreover advanced.

With the proposed blend microgrid course of action, the contrasting force control contrives, and the low exchange speed correspondence system between string converter central controller and little converter close by controllers, all smaller than expected converters in the structure can participate in the power participating in the two organizations tied and islanding microgrid action modes in a decentralized manner.

## X. REFERENCES

### BOOKS

FLÁVIA DE ANDRADE, M. C. (n.d.). **Basic Tutorial on Simulation of Microgrids Control Using MATLAB® & Simulink® Software.**

MAHMOUD, M. S. (n.d.). **MICROGRID Advanced Control Methods and Renewable Energy System Integration.**

### ARTICLES

B. LIANG, Y. W. (2016). **A series-DG based autonomous islanding microgrid.** IEEE Applied Power Electronics Conference and Exposition (APEC), 1249-1252.

B. XIAO, L. H. (Mar./Apr. 2015). **Modular cascaded H-bridge multi-level PV inverter with distributed MPPT for grid-connected applications.** IEEE Trans. Ind. Appl., vol. 51, no. 2, 1722–1732.

C. D. TOWNSEND, Y. F. (Aug. 2014). **Cascaded H-bridge multilevel PV topology for alleviation of per-phase power imbalances and reduction of second harmonic voltage ripple.** IEEE Trans. Power Electron., vol. 31, no. 8, 5574-5586.

DANIEL MONTESINOS-MIRACLE, M. S. (2018). **An Enhancing Fault Current Limitation Hybrid Droop/V-f Control for Grid-Tied Four-Wire Inverters in AC Microgrids.** Appl. Sci. 2018, 8, 1725, 3-24.

H. HAN, Y. L. (Jun. 2015). **An improved droop control strategy for reactive power sharing in islanded microgrid.** IEEE Trans. Power Electron., vol. 30, no.6, 3133–3141.

H. MAHMOOD, D. M. (Dec. 2014). **A power management strategy for PV/battery hybrid systems in islanded microgrids.** IEEE Journal of Emerging and Selected Topics in Power Electronics, vo. 2, no. 4, 870-882.

- H. MAHMOOD, D. M. (Sep. 2015). **Strategies for independent deployment and autonomous control of PV and battery units in islanded microgrids.** IEEE Journal of Emerging and Selected Topics in Power Electronics, vo. 3, no. 2, 742-755.
- HE, J., LI, Y., WANG, C., PAN, Y., ZHANG, C., & XING, X. (June 2018). **Hybrid Microgrid with Parallel- and Series-Connected Micro converters.** IEEE Transactions on Power Electronics Volume: 33, Issue: 6, 4817 - 4831.
- J. M. GUERRERO, J. C. (Jan. 2011). **Hierarchical control of droop-controlled AC and DC microgrids - A general approach toward standardization.** IEEE Trans. Ind. Electron., vol. 55, no. 1, 158 - 172.
- J. M. GUERRERO, L. G. (Aug. 2005). **Output impedance design of parallel-connected UPS inverters with wireless load sharing control.** IEEE Trans. Ind. Electron., vol. 52, no. 4, 1126-1135.
- J. M. GUERRERO, L. G. (Sep 2004). **A wireless controller to enhance dynamic performance of parallel inverters in distributed generation systems.** IEEE Trans. Power Electron., vol. 19, no. 4, 1205-1213.
- K. D. BRABANDERE, B. B. (Jul. 2007). **A voltage and frequency droop control method for parallel inverters.** IEEE Trans. Power Electron., vol. 22, 1107–1115.
- L. ASIMINOAEI, F. B. (2007.). **Detection is key - Harmonic detection methods for active power filter applications.** IEEE Industry Applications Magazine, vol. 13. no. 4, 22 – 33.
- L. LIU, H. L. (Jan. 2015). **Decoupled active and reactive power control for large-scale grid-connected photovoltaic systems using cascaded modular multilevel converters.** IEEE Trans. Power Electron., vol. 30, no. 1, 176-187.
- L. ZHANG, K. S. (n.d.). **A grid-tied photovoltaic generation system based on series-connected module integrated inverters with adjustable power factor.** in Conf. Rec. ECCE'15. Montreal, Canada.

- LASSETER, R. H. (2002). **Microgrids**. IEEE Power Engineering Society Winter Meeting, 305-308.
- LI, J. H. (May. 2014). **An enhanced microgrid load demand sharing strategy**. IEEE Trans. Power Electron., vol. 19, no. 5, 1184-1194.
- LI, J. H. (Nov/Dec. 2011). **Analysis, design and implementation of virtual impedance for power electronics interfaced distributed generation**. IEEE Trans. on Ind. Appl., vol. 47, 2525-2538.
- LI, Y. L. (Mar. 2011.). **Power management of inverter interfaced autonomous microgrid based on virtual frequency-voltage frame**. IEEE Trans. Smart Grid, vol. 2, 30-40.
- LIU, J., & Y. MIURA, Y. T. (May, 2016). **Comparison of dynamic characteristics between virtual synchronous generator and droop control in inverter-based distributed generators**. IEEE Trans. Power Electron., vol. 31, no. 5, 3600-3611.
- LU, F. (2016). **Autonomous Control of Series-Connected Low Voltage Microinverters (LVAC) for Photovoltaic Panels**. Colorado US: Department of Electrical, Computer and Energy Engineering, University of Colorado Boulder, U.S .
- LYONS, E. J. (Mar. 2003). **The sliding DFT**. IEEE Signal Process. Mag., vol. 20, no. 2, 74–80.
- M. NUOTIO, M. I. (2014). **Innovative AC photovoltaic module system using series connection and universal low-voltage microinverters**. IEEE Photovoltaic Specialist Conference (PVSC), 1367–1369.
- Q. SHAFIEE, J. M. (Feb. 2014). **Distributed secondary control for islanded microgrids—A new approach**. IEEE Trans. Power Electron., vol. 29, no. 2, 1018–1031.
- ZHONG, Q.-C. (Mar. 2013). **Harmonic droop controller to reduce the voltage harmonics of inverters**. IEEE Trans. Ind. Electron., vol. 60, no. 3, 936–945.

- XING, Z. H. (Aug. 2008). **Distributed control for UPS modules in parallel operation with RMS voltage regulation**. IEEE Trans. Ind. Electron., vol. 55, no.8, 3133–3141.
- Y. YU, G. K. (Jan. 2016). **Power balance of cascaded H-bridge multilevel converters for large scale photovoltaic integration**. IEEE Trans. Power Electron., vol. 31, no. 1, 292-303.
- Y. ZHU, F. Z. (May, 2016). **A virtual impedance optimization method for reactive power sharing in networked microgrid**. IEEE Trans. Power Electron., vol. 31, no. 4, 2890-2904.
- ZHANG, Q.-C. (Apr. 2013). **Robust droop controller for accurate proportional load sharing among inverters operated in parallel**. IEEE Trans. Ind. Electron., vol. 60, no. 4, 1281–1290.
- X. LU, K. S. (Jun. 2014). **State-of charge balance using adaptive droop control for distributed energy storage systems in DC microgrid applications**. IEEE Trans. Ind. Electron., vol. 61. no. 6, 2804 – 2815.
- X. LU, J. M., & HUANG, L. (Feb. 2014). **Hierarchical control of parallel AC-DC converter interfaces for hybrid microgrids**. IEEE Trans. Smart Grid, vol. 2. no. 2, 683 – 692.
- X. LU, J. M. (Apr. 2013). **An improved droop control method for DC microgrids based on low bandwidth communication with DC bus voltage restoration and enhanced current sharing accuracy**. IEEE Trans. Power Electron., vol. 29, no.4, 1900–1812.
- WOLFS, Q. L. (May. 2008). **A review of the single-phase photovoltaic module integrated converter topologies with three different DC link configuration**. IEEE Trans. Power Electron., vol. 23, no. 3, 1320-1333.
- TAHA SELIM USTUN, C. O. (n.d.). **A Microgrid Protection System with Central Protection Unit and Extensive Communication**. 978-1-4244-8782-0/11/\$26.00 ©2011 IEEE.
- Q-C. ZHONG, P.-L. N. (Feb 2014). **Self-synchronized synchronverters: inverters without a dedicated synchronization unit**. IEEE Trans. Power Electron., vol. 29, no. 2, 617-630.

M. SAVAGHEBI, A. J. (Apr. 2013). **Autonomous voltage unbalance compensation in an islanded droop controlled microgrid**. IEEE Trans. Ind. Electron., vol. 60, no. 4, 1390–1402.

## **ELECTRONIC SOURCES**

Energy, U. D. (2014, JUNE 17). **How Microgrids Work**. Retrieved from Energy.gov:  
<https://www.energy.gov/articles/how-microgrids-work>

Media, M. (2017, Jan 13). **Types of Microgrids**. Retrieved from microgridprojects:  
<http://microgridprojects.com/>

## **DISSERTATIONS**

F. LU, B. C. (2015). **Autonomous control of series-connected low voltage photovoltaic microinverters**. 2015 IEEE 16th Workshop on Control and Modeling for Power Electronics (COMPEL).

MASSAWE, H. (2013). **Grid Connected PV Systems with Smart Grid functionality**. (published MSc Thesis) Department of Electric Power Engineering, Norwegian University of Science and Technology .

## **OTHER SOURCES**

ASIAN DEVELOPMENT BANK. (JULY 2020.). **Handbook on Microgrids for Power Quality and Connectivity**. ASIAN DEVELOPMENT BANK.

CHRISTINE SCHWAEGERL. (December 30th, 2009). **DG3&DG4. Report on the technical, social, economic, and environmental benefits provided by Microgrids on power system operation**. Advanced Architectures and Control Concepts for MORE MICROGRIDS, Siemens AG.

OUDALOV, A. (11 November 2009). **“Novel protection systems for microgrids”**, Advanced Architectures and Control Concepts for MORE MICROGRIDS.



## APPENDIX

### Matlab Variables for Thesis

```
% -----  
% Generated by MATLAB on 1-Feb-2021 22:45:42  
% MATLAB version: 9.8.0.1323502 (R2020a)  
% -----  
  
saveVarsMat = load('matlab.mat');  
  
Ds = 0.00015625;  
  
E = 220;  
  
Freq_step = 94.247779607693786;  
  
Freq_step_in = 0.2;  
  
Freq_step_out = 1;  
  
H = saveVarsMat.H; % <1x1 tf> unsupported class  
  
Harmonic_in = 0.5;  
  
Harmonic_out = 0.85;  
  
Hd = saveVarsMat.Hd; % <1x1 tf> unsupported class  
  
Hdden = [1 -0.99449095900190587];  
  
Hdnum = [0.0027570566177099872 0.0027519843803841485];  
  
Mag_step = -44;  
  
Mag_step_in = 1.2;  
  
Mag_step_out = 1.35;  
  
Offset_in = 1.5;  
  
Offset_out = 1.7;  
  
Ph_jump = 1.5707963267948966;  
  
Ph_jump_in = 1.75;  
  
Ph_jump_out = 2;
```

### Matlab variables for thesis (continued)

```
angn = -2.6179938779914944;
```

```
angp = 0;
```

```
angz = 0.17453292519943295;
```

```
fg = 50;
```

```
fgnom = 50;
```

```
fnom = 50;
```

```
k = 0.70710678118654746;
```

```
k3 = 0.7;
```

```
k5 = 0.6;
```

```
k7 = 0.3;
```

```
k9 = 0.2;
```

```
logout = saveVarsMat.logout; % <1x1 Simulink.SimulationData.Dataset>  
unsupported class
```

```
magn = 60;
```

```
magp = 220;
```

```
magz = 20;
```

```
n = 128;
```

```
nb = 256;
```

```
nf = 2;
```

```
tend = 2.25;
```

```
tout = saveVarsMat.tout; % <32001x1 double> too many elements
```

```
wf = 35.35533905932737;
```

```
clear saveVarsMat;
```

# CURRICULUM VITAE

**Name Surname:** LEONARD BAIYE ENOW

**Date and Place of Birth:**

**Email:**

## EDUCATION:

- Bachelor:** 2017, The University Institute OF Technology DOUALA, Industrial Engineering & Maintenance.
- Masters:** 2021, Istanbul Aydin University, Institute OF Graduate Studies, Electrical & Electronic Engineering.

## PROFESSIONAL EXPERIENCE AND AWARDS:

**PUBLICATIONS FROM DISSERTATION, PRESENTATIONS AND PATENTS:**