

ANKARA YILDIRIM BEYAZIT UNIVERSITY

GRADUATE SCHOOL OF NATURAL AND APPLIED SCIENCES



LOW-COST PERIMETER SECURITY

RADAR SYSTEM

M.Sc. Thesis by

Abdulrahim Evli

Department of Electrical and Electronics Engineering

December 2020

ANKARA

Low-Cost Perimeter Security Radar System

A Thesis Submitted to

The Graduate School of Natural and Applied Sciences of

Ankara Yıldırım Beyazıt University

**In Partial Fulfilment of the Requirements for the Degree of Master of Science in
Electrical and Electronics Engineering, Department of Electrical and
Electronics Engineering**

by

Abdulrahim Evli

December 2020

ANKARA

M.Sc. THESIS EXAMINATION RESULT FORM

We have read the thesis entitled “**LOW-COST PERIMETER SECURITY RADAR SYSTEM**” completed by **ABDULRAHİM EVLİ** under the supervision of **PROF. DR. ASAF BEHZAT ŞAHİN** and we certify that in our opinion it is fully adequate, in scope and in quality, as a thesis for the degree of Master of Science.

Prof. Dr. Asaf Behzat ŞAHİN

Supervisor

Assoc. Prof. Dr. Enver ÇAVUŞ

Jury Member

Prof. Dr. Hakan ALTAN

Jury Member

Prof. Dr. Ergün ERASLAN

Director

Graduate School of Natural and Applied Science

ETHICAL DECLARATION

I hereby declare that, in this thesis which has been prepared in accordance with the Thesis Writing Manual of Graduate School of Natural and Applied Sciences,

- All data, information and documents are obtained in the framework of academic and ethical rules,
- All information, documents and assessments are presented in accordance with scientific ethics and morals,
- All the materials that have been utilized are fully cited and referenced,
- No change has been made of the utilized materials,
- All the works presented are original,

and in any contrary case of above statements, I accept to renounce all my legal rights.

December 2020

Signature:

Name & Surname: Abdulrahim Evli

ACKNOWLEDGEMENTS

Firstly, I would like to express my deep and sincere gratitude to my supervisor Prof. Dr. Asaf Behzat Şahin for the support throughout my M.Sc. thesis and research, for his motivation, enthusiasm, patience and immense knowledge. His guidance helped me make this thesis possible.

Beside my advisor, I would like to extend my sincere appreciations to my thesis defense committee members: Assoc. Prof. Dr. Enver Çavuş, Prof. Dr. Hakan Altan and Graduate School of Natural and Applied sciences director Prof. Dr. Ergün Eraslan.

I would like to present my greatest gratitude to my family: my parents for their dedication and spiritual support throughout the writing of this thesis. I would like to dedicate this thesis to my parents for their unconditional love that they gave me through whole my life.

From the bottom of my heart, I would like to thank the group of Terahertz Signal Processing and Communications. My sincere thanks go to Rsc.Ast. Murat Can Karakoç, Dr. Anıl Reşat, Ziaourahman Sediqi and Ali Narin for the work.

I would like to thank Ankara Yıldırım Beyazıt University Graduate School of Natural and Applied Sciences and Department of Electrical and Electronics Engineering academic staff, research assistants, my labmates and personnel that provided me a supportive and friendly workplace environment.

Finally, this thesis study is supported by the Scientific and Technological Research Council of Turkey (TÜBİTAK) under the 1003 project High Resolution Capacitive Micro Machined Ultrasonic Transducer Ultrasound Imaging System (Project No: 116E659).

December 2020

Abdulrahim Evli

LOW-COST PERIMETER SECURITY RADAR SYSTEM

ABSTRACT

Radar systems are needed for various reasons. Perimeter security was previously provided by people constantly watching with binoculars or cameras. This attempting to personally ensure security environment has brought some negative aspects such as security weakness. With the development of modern technology such negativities began to disappear. With the use of radar systems in the military and civilian fields, it started to give humanity a sigh of relief. But the fact that perimeter security radar systems can be provided at a very expensive cost has continued people's search. The purpose of this thesis study is to develop a low-cost pulse radar system with suitable range.

In this thesis study, the theoretical part of radar systems has been explained and the working principle of conventional pulse radars has been emphasized. In addition to this, carrier pulse signals are examined in time and frequency domains. In this thesis, low-cost radar system design is focused on using HB100 X-Band microwave motion sensor, low noise block converter and analog satellite finder. HB100 sensor, low noise block converter and analog satellite finder are cheap components that are used in daily life and that we can easily access. HB100 X-Band motion sensor is used for carrier signal generator. This sensor is modulated with the function generator and the pulse signal is obtained. The response of the system has been observed by changing the pulse repetition frequency and pulse interval of this carrier signal as desired. Low noise block converter, used on front of the satellite antenna, and analog satellite finder are used in the receiver. The analog satellite finder, which is used as a power detector, is used to correctly position the direction of TV satellite antennas in daily life.

By observing the received signal on the oscilloscope, it has been revealed that the developed radar system has a serious potential for the target detection.

Keywords: Pulse radar system, X-Band, Low noise block converter, Analog satellite finder, HB100 sensor.

DÜŞÜK BÜTÇELİ ÇEVRESEL GÜVENLİK RADAR SİSTEMİ

ÖZ

Radar sistemleri günümüzde çeşitli sebeplerle sıkça ihtiyaç duyulmaktadır. Çevresel güvenlik eski zamanlarda insanların dürbünle veya kamera ile sürekli gözetlemesi ile birlikte sağlanmaktaydı. Bu kişisel olarak güvenliğin sağlanmaya çalışılması güvenlik zafiyeti gibi bazı olumsuzlukları ortama getirmiştir. Modern teknolojinin gelişmesiyle birlikte bu tür olumsuzluklar ortadan kalkmaya başlamıştır. Radar sistemleri askeri ve sivil alanda kullanılmaya başlaması ile birlikte insanlığa rahat bir nefes aldirmaya başlamıştır. Ama güvenlik radar sistemlerinin çok pahalı bir maliyet ile temin edilebilmesi insanları arayışlara süreklemiştir. İşte bu tezin amacı düşük maliyet ile uygun menzilde radar sistemi tasarlamaktır.

Bu yapılan tez çalışmasında radar sistemlerinin teorik kısmı anlatılmış olup, geleneksel darbe radarlarının çalışma prensibi üzerinde durulmuştur. Diğer taraftan taşıyıcı darbe sinyalleri zaman ve frekans domeninde incelenmiştir. Bu tez çalışmasında, HB100 X-Bant mikrodalga hareket sensörü, düşük gürültülü blok dönüştürücü ve analog uydu bulucu kullanılarak düşük maliyetli radar sistemi tasarımı üzerinde durulmuştur. HB100 sensörü, düşük gürültülü blok dönüştürücü ve analog uydu bulucu, günlük hayatta kullanılan ve kolayca erişebileceğimiz ucuz komponentlerdir. Taşıyıcı sinyal üretici için HB100 X-Bant hareket sensörü kullanılmıştır. Bu sensör fonksiyon üretici ile modülasyon edilerek darbe sinyali elde edilmiştir. Bu taşıyıcı sinyalin darbe tekrarlama frekansı ve darbe aralığı istenildiği gibi değiştirilerek, sistemin tepkisi gözlemlenmiştir. Alıcıda ise uydu antenlerin ön kısmında kullanılan düşük gürültülü blok dönüştürücü ve analog uydu bulucu kullanılmıştır. Güç detektörü olarak kullanılan analog uydu bulucu ise günlük hayatta TV uydu antenlerin yönünü doğru konumlandırılmasında kullanılmaktadır.

Osiloskopta alınan sinyal gözlemlenerek, geliştirilen radar sisteminin hedef tespit edebilme konusunda ciddi bir potansiyele sahip olduğu ortaya konulmuştur.

Anahtar Kelimeler: Darbe radar sistemi, X-Bant, Düşük gürültülü blok dönüştürücü, Analog uydu bulucu, HB100 sensör.

CONTENTS

M.Sc. THESIS EXAMINATION RESULT FORM	ii
ETHICAL DECLARATION	iii
ACKNOWLEDGEMENTS.....	iv
ABSTRACT	v
ÖZ.....	vi
NOMENCLATURE	ix
LIST OF TABLES	x
LIST OF FIGURES	xi
CHAPTER 1	1
1.1 Significance of the Study	4
1.2 Motivation	5
1.3 Purpose of the Thesis	5
1.4 Thesis Structure	6
CHAPTER 2	7
2.1 Radar Theory	7
2.2 The Radar Equation.....	8
2.3 Resolution and Accuracy.....	11
2.4 Radar Cross Section	13
2.5 Radar Frequencies	15
2.6 Pulse Radar.....	16
CHAPTER 3	22
3.1 Transmitter Subsystem.....	22
3.1.1 HB100 X-Band microwave motion sensor	22
3.2 Receiver Subsystem	26
3.2.1 Low Noise Block Downconverter	26
3.2.1.1 Feedhorn.....	27

3.2.1.1.1 Polarization.....	28
3.2.1.2 Single Band LNB	28
3.2.1.3 Dual Band LNB (Universal LNB)	29
3.2.1.4 Low Noise Amplifier	30
3.2.1.5 Block downconversion.....	30
3.2.2 Analog Satellite Finder	32
3.3 System Verification.....	33
CHAPTER 4	43
CHAPTER 5	51
REFERENCES.....	53
CURRICULUM VITAE.....	57

NOMENCLATURE

Acronyms

ASK	Amplitude Shift Keying
BW	Bandwidth
DRO	Dielectric Resonator Oscillator
EM	Electromagnetic
EO	Electro-optic
F	Noise Factor
GBP	Gain Bandwidth product
LNA	Low Noise Amplifier
LNB	Low Noise Block Downconverter
LO	Local Oscillator
MDS	Minimum Detectable Signal
NF	Noise Floor
OOK	On-Off Keying
PRF	Pulse Repetition Frequency
PRI	Pulse Repetition Interval
RCS	Radar Cross Section
RF	Radio Frequency
RSS	Received Signal Strength
SNR	Signal-to-Noise Ratio
Sqm	Square Meter
W	Watt

LIST OF TABLES

Table 2. 1 Typical radar cross section values [21]	13
Table 2. 2 Standart radar-frequency letter-band nomenclature [4].	16
Table 3. 1 Sensor Specifications.	23
Table 3. 2 LNB Polarization.....	28
Table 3. 3 Dual band LNB.	29



LIST OF FIGURES

Figure 2. 1 Typical operation of a radar system [1].....	7
Figure 2. 2 Monostatic Radar and Bistatic Radar [17].....	9
Figure 2. 3 Range resolution of two targets [20].....	12
Figure 2. 4 Example for the ability to separate targets at different ranges [20].....	12
Figure 2. 5 Backscatter from objects having different shapes [22].....	14
Figure 2. 6 RCS of the sphere	14
Figure 2. 7 Radar frequencies and the electromagnetic spectrum [4]	15
Figure 2. 8 Time diagram of the transmitter modulation	17
Figure 2. 9 Three ways of increasing average power.....	19
Figure 2. 10 Pulse Radar System	20
Figure 3. 1 HB100 Doppler sensor module.....	22
Figure 3. 2 The schematic of the HB100 microwave sensor	24
Figure 3. 3 Radiation Pattern.....	24
Figure 3. 4 Doppler effect	25
Figure 3. 5 Low Noise Block Downconverter [30].....	27
Figure 3. 6 LNB PCB Board [30]	30
Figure 3. 7 The circuit design of the satellite finder [6].....	33
Figure 3. 8 System design schematic	33
Figure 3. 9 Transmitter and Receiver.....	35
Figure 3. 10 Modulating Pulse	36
Figure 3. 11 RF carrier	36
Figure 3. 12 Modulated CW signal	36
Figure 3. 13 The basic concept of the modulating pulse.....	37
Figure 3. 14 System setup	38

Figure 3. 15 Schematic of the Low Noise Block Downconverter [32].....	39
Figure 3. 16 Envelope demodulator circuit.....	40
Figure 3. 17 Amplitude Demoduation [65].....	41
Figure 3. 18 Non-inverting feedback amplifier.....	42
Figure 4. 1 Input power-output voltage relation	43
Figure 4. 2 Op-amp gain and frequency response.....	44
Figure 4. 3 Rise time	45
Figure 4. 4 Spectrum of the rectangular pulse	46
Figure 4. 5 Echo signals.	47
Figure 4. 6 SNR-Target range relation.....	49
Figure 4. 7 Receiver operating characteristic curve.....	50

CHAPTER 1

INTRODUCTION

For many years, radar technology systems have been recognized as the essential instrument for the remote detection and observation. It has developed by using electromagnetic wave that sending a waveform to target such as pulse modulated sine wave or continuous wave. This radar system detects the reflections from the target above threshold voltage and processing the signal for target information such as range and velocity. Human eye sometimes is insufficient to observe environment and risks under some conditions, but radars have wide capability even in the bad weather conditions. The history of the perimeter security is focused on construction clasps and barriers [1]. This fundamental idea has developed into activity detection along the fences across a range of sensors. There are currently a range of wire and fiber sensors for mounting on an enclosure as well as various IR, radar, optical, seismic, acoustic and sealing sensors for mounting along the fence line [2-3]. Perimeter security radar sensors can provide broad area observation unlike traditional cameras, can operate in all hard conditions effectively. The basic criteria for surveillance radars lead to the possibility of sensing moving persons, groups of individuals, smaller cars [3]. They can continue to control the specified border area independently. Security radars collaborate with other equipments such as cameras, thermal imaging systems, laser-based systems.

A basic radar includes transmitting antenna, radiate electromagnetic (EM) wave produced by an oscillator, and a receiving antenna to detect echo signal by the target. Target intercepts some part of transmitting electromagnetic wave by the source and reradiated waves towards to source in all directions. Obtained reflected energy by the receiver antenna process it for target information. Distance between target and radar system and relative velocity of the target would be detected by processing received energy. Measuring time between transmitting signal and received signal gives the range information from source to target. Time of flight is determined by using pulse waveform shape sending from the radars. When pulse waveform is transmitted by the

radar source to target, before the next pulse wave is emitted by the radar source, there must be sufficient time to come echo signal. Receiver must be turn off to block interferences with reception during the transmission. Also, high pulse repetition frequency can cause the misleading results in measuring distances since echo signal could be detected after the next pulse is transmitted. The angular position or the direction of the object would be obtained with narrow beamwidths from the direction of received echo wavefront [4]. Velocity of the target is determined by shifting carrier frequency of reflected wave (Doppler effect) [5]. It is also possible to track the change of a target position continually by using radar system. Determine the range is one of the most important capability because no technique can not measure range as well or as rapidly as a radar can, but current radars have much capability about extracting information from the echo signal rather than measuring distance [4].

Radar history usually begins with experiments performed by Heinrich Hertz at the end of the 19th century to test the theory of James Clerk Maxwell on the electromagnetism [6]. The first idea is to use radio echoes detecting device designed to avoid collisions in marine navigation and used radio echoes to determine the height of the ionosphere [7]. As Heinrich Hertz conducted his experiments on radio frequency waves, he found that the artifacts around him interfered with the radio waves [68]. At the turn of the last century, scientists learned about how to use this intrusion by the phenomena of this intrusion [8]. Tesla proposed that reflected electromagnetic waves could be used to detect objects and even measure the range with wireless system through 1900 [9]. Tesla defined the theory of the radar like echo of sound and reflection of voice from the wall or mountain. Ideas of the Tesla was not realized because of some problems and were forgotten his ideas day by day.

This idea is used by the German inventor Christian Hülsmeyer develop the ship detector to escape from the crash in fog [10]. He gives name to it as a Telemobiloskop and took its patent. The Second World War in September 1939, Watson Watt had designed the first radar system to warn of the approach of enemy aircraft [6-11]. In the recent years, capability of radars is developed to extract more formation rather than measurement of range.

Radar technology is used in many different areas (e.g. aviation, automotive industry, military areas). Radar uses radio waves to determine the range, angle or velocity of the objects. Radars originally was developed to detect terrain, ships, spacecraft, guided missiles, and weather formations. Perimeter security radars (PSR) are efficient tools for different perimeter security protection function. PSR is a class of radar sensors specifically designed for detection at the ground level of targets such as an individual walking or crawling towards a facility, as well as low flying aircraft and drones in and around high-sensitivity areas [1-12-13]. In these applications, target tracking and object recognition algorithms have been worked and radar-EO sensor fusion techniques are applied [12-14]. Security radars can be used for:

- Base protection;
- Perimeter and Critical National Infrastructure protection;
- Airport, port or harbor security;
- Drone detection radar;
- Wildlife and game reserve observation;
- Military battlefield surveillance radar;
- Border Security

PSR don't need operator because they autonomously detect moving objects in a certain area and track these objects since they can operate under any enviromental conditions. If the target exists in the alarm areas, alarm start to operate. Perimeter surveillance radars generally observe areas between 80° and 360° . Beamwidth of the millimeter radars should be as possible as narrow for high accuracy and resolution. Perimeter security radars work at high frequencies such as X-Ku band and modulation characteristics include FMCW, and pulsed. The detection capabilities of such radars range from several hundered meters to over a couple of 10 kilometers.

In the modern years, rising requirement for security systems at industrial areas has driven great advancements in security technologies since security camera video analytic are insufficient due to some surveillance problems. The priority task of these radars is to recognize movements of targets such as a person or a car approaching an area for security purposes, military services.

In this study, a low-cost pulse radar system has been developed by using the X-band microwave motion sensor module HB100, low noise block (LNB) and analog satellite finder to ensure environmental safety. The cost of this radar system is very cheap compared to commercial radars for the perimeter surveillance. Cost of HB100, LNB and analog satellite finder is about 5\$, 5\$, 10\$, respectively. The total cost of the project is about 20\$. HB100 is used as a signal generator in the transmitter. A function generator is adjusted to generate a square wave to modulate the 10.525 GHz carrier frequency signal generated by HB100 module in order to detect fixed target range with a separate receiver system. LNB and analog satellite finder is the receiver parts in this study. The reflected attenuated signal from the target is amplified and down-converted to a low frequency by the help of LNB used at the receiver side. Another part of the receiver is the analog satellite finder, which is used as a power detector that demodulates the signal received from the LNB then the demodulated signal is observed at the oscilloscope. A low-cost radar system that can detect targets up to 168 meters, has been developed where the HB100 module is used as a high frequency carrier signal generator about 10.525 GHz. The LNB and analog satellite finder are used at the receiver part of the radar system as a RF front end.

1.1 Significance of the Study

Perimeter security radars are becoming more important for several reasons. The most significant thing is that the safety supervision system incorporates radar technology integrated software and CCTV in an unmatched manner, to recognise hazards and to sensitize situations. Robust, sustainable and working in extreme conditions. The importance of this research is to develop a perimeter security radar system at the X-Band. The result of the study is as follows:

- The study of the radar systems
- Design of a radio frequency (RF) system for X-band
- Developing of a cost-effective radar system

1.2 Motivation

Radar systems are a crucial part of most physical security systems. Protection of critical structures is a growing concern in high security areas. The history of perimeter security is based on building fences and barriers. However, today it is not enough to make fences or barriers, but environmental safety must be ensured with various measures. Thus, the perimeter security system has turned into detecting activity along the fence or barrier using various sensors. Recently, it is widely used in many areas for critical infrastructure protection such as environmental security systems, border security, government building security, airport security, railway and oil line security, wide area surveillance, etc. There are many sensors to be used for security purpose such as infrared, radar, electro-optic (EO), acoustic sensor etc. Although optical systems are used efficiently, weather and lighting conditions reduce the efficiency of the system. Since radars is not affected weather or light conditions, they are mostly preferred for perimeter surveillance systems. There are many methods to ensure perimeter security. In our study, low-cost components motivated research in the radar system application for the perimeter security system. This experimental application provides the engineers detecting moving objects with low-cost components for the security.

1.3 Purpose of the Thesis

A main purpose of this thesis is to design perimeter surveillance radar system with low- cost budget. Some goals that are tried to be achieved in this thesis. One of the goals of this research is to detect targets over 150 meters with cheap components. Radars is normally used for the security and civil purposes, quite expensive, and the need for using is increasing day by day. In this research, total cost of this experimental research which is quite cheap, is about 20\$. In this research, HB100 microwave motion sensor is used as a transmitter. On the other hand, LNB is used as a receiver part and analog satellite finder which another part of the receiver system, used as a power detector in this experiment. Analog satellite finder is normally used to increase sensitivity of the satellite TV receiver while adjusting satellite antenna. These

components are combined to develop a pulse radar system with low cost at the X-Band.

1.4 Thesis Structure

This experimental study is consisted of five chapters; chapter one includes introduction which gives a brief background introduction, importance of study, motivation and purpose of the study are given. Chapter two covers general information about radar systems and components of this study. Chapter three is talking about experimental setup in details where it shows how developed low-cost radar system in X-Band. Chapter four gives the results obtained from the experimental setup and conclusion and recommaditions are mentioned in chapter 5.

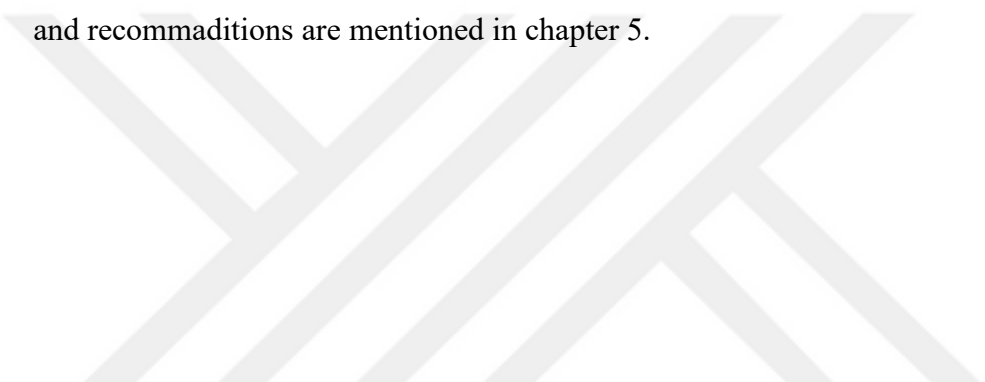

CHAPTER 2

FUNDAMENTALS AND LITERATURE REVIEW

2.1 Radar Theory

Radar is a sensor which is developed for detection, tracking or imaging objects that reflect electromagnetic waves [15]. Range, radial velocity, and angular velocity can be obtained by processing the received signal and good resolution can provide shape or size of the target [16].

In the principle of radar application, a transmitter emits EM wave to target generated by an oscillator. This process can be achieved under different conditions such as rain, fog, snow and daytime night/night. A portion of electromagnetic waves reflected from target and scattered in all directions. Echo signal is got by the receiver antenna and EM wave is send to receiver for the signal processing. By evaluating this received signal, it can be reached to the direction, range, height and an even image information about the target. The basic concept figure is shown in figure 2.1.

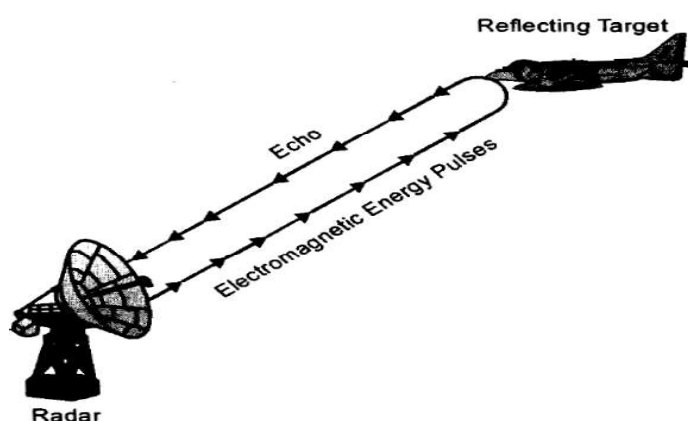

Figure 2. 1 Typical operation of a radar system [1].

Radar systems can be used in the many areas [16]

Civilian Applications

- Velocity measurement
- Height measurement
- Alarm systems
- Mapping
- Weather forecasts

Military Applications

- Missile systems
- Detection of air vessels
- Fire control systems
- Enemy surveillance systems

Scientific areas

- Space researches
- Mapping
- Remote monitoring
- Precise distance measurement

2.2 The Radar Equation

The radar equation is based on the characteristics of the transmitter and receiver power, antenna, object, and environment. It is useful not only for distance determination from the radar to the object, but also as a way of interpreting the function of the radar and as a base for designing [4]. In this section, we represent radar equations.

P_t represents the output power radiated by the transmitter antenna. Isotropic antennas radiate uniformly in all directions. S_t represents power density, can be found at a distance R divided by the surface area $4\pi R^2$ of an imaginary sphere of radius R . Power density from isotropic antenna

$$S_t = \frac{P_t}{4\pi R^2} \quad (2.1)$$

Directional antennas are used to increase the power density in a particular direction and generally characterized by antenna gain G and effective aperture A_e . According to

monostatic antenna, the power density at a distance R away from a radar utilizing a directive antenna of gain is represented by the P_d

$$P_D = \frac{P_t G}{4\pi R^2} [W m^{-2}] \quad (2.2)$$

In the monostatic radars, same antenna is used both transmitter and receiver while bistatic radars use different antennas for transmitter and receiver. The Figure 2.2 represents two basic radar systems.

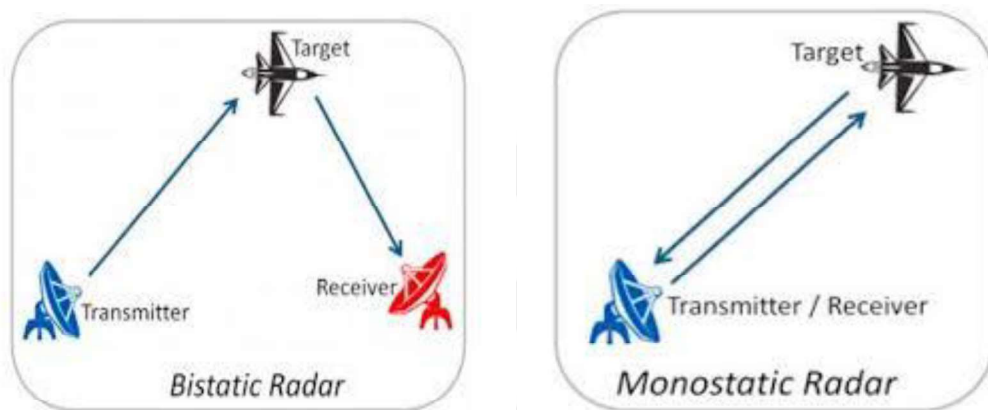

Figure 2. 2 Monostatic Radar and Bistatic Radar [17].

A portion of transmitted power is reradiated to different directions from the target. The measure of the amount of incident power intercepted by the target and reradiated back in the direction of the radar is denoted as the radar cross section σ . Power density of echo signal at radar

$$\frac{P_t G}{4\pi R^2} \frac{\sigma}{4\pi R^2} \quad (2.3)$$

The radar cross section (RCS) σ is defined by units of area. RCS is the ratio of the reradiated power to radar direction to the incident power density on the target and symbolized by the units of m^2 . The radar receiver antenna obtains a part of the reflected power. The effective area of the receiving antenna is denoted A_e received total power P_r by the receiver of the radar

$$P_r = \frac{P_t G A_e \sigma}{(4\pi)^2 R^4} \quad (2.4)$$

Minimum detectable signal (MDS) is the minimum power level for the processing the signal for the output. MDS can also be interpreted as the input signal power to obtain a particular SNR at the output. In the radar systems, it can be defined as a minimum discernible signal that measuring lowest input signal that can be recognized above background noise. The measurement of the lowest detectable signal at the receiver is one of the significant factors to determine the maximum target range. Minimum detectable signal power is defined by the S_{min} and maximum range R_{max} is obtained when echo signal P_r obtained is equivalent to the minimum detectable signal S_{min}

$$R_{max} = \left[\frac{P_t G^2 \lambda^2 \sigma}{(4\pi)^3 S_{min}} \right]^{1/4} \quad (2.5)$$

Antenna theory represents the relationship between the transmitter antenna gain and the receiving effective area of an antenna as

$$G = \frac{4\pi A_e}{\lambda^2} \quad (2.6)$$

Substituting (2.6) into equation (2.5)

$$R_{max} = \left[\frac{P_t A_e^2 \sigma}{4\pi \lambda^2 S_{min}} \right]^{1/4} \quad (2.7)$$

In the bistatic radars, transmitter and receiver antenna is used separately. Unlike monostatic radar, transmitter and receiver antennas is placed by a distance in the bistatic radar [18]. In the bistatic radar equation, received power P_R is given below equation

$$P_R = \frac{P_T G_T G_R \lambda^2 \sigma L_{tr}}{(4\pi)^3 R_T^2 R_R^2} \quad (2.8)$$

In equation 2.8, G_R and G_T are the receiver and transmitter gain, respectively, λ is the wavelength of the transmitted signal, L_{tr} is the transmitter and receiver way loss. SNR is the ratio of the received power to noise power of the receiver system. Received noise power

$$P_N = k T_0 B F \quad (2.9)$$

k is Boltzmann's constant ($1.38 \times 10^{-23} \text{ J K}^{-1}$)

T_0 is the absolute temperature (290 K)

B is the receiver bandwidth (Hz)

F is the receiver noise factor

Noise figure is the ratio input SNR to output SNR of the receiver. It is the noise factor (F) but defined by dB unit.

$$\text{SNR} = \frac{P_r}{P_N} = \frac{P_t G_t G_r \lambda^2 \sigma}{(4\pi)^3 R^4 k T_0 B F} \quad (2.10)$$

2.3 Resolution and Accuracy

Accuracy of radar range measurement is a measure for how great tolerances in order to determine target range. Range accuracy measurement depends fundamentally on the SNR and bandwidth. While runtime measurement of pulse signal, a time point of received signal is chosen above the the threshold voltage, 0.707 of the maximum voltage, but detectable edge of the echo signal is obtained early due to noise on the signal. Lower SNR leads to poor range accuracy. Range accuracy is defined by ΔR

$$\Delta R = \frac{c}{2B\sqrt{2SNR}} \quad (2.11)$$

Range resolution is the ability of the radar, determines how close different objects in different ranges can be spaced in order to be differentiation of the targets [19]. This ability related to bandwidth. Pulse width τ may be given in the frequency domain as a B , and is related to bandwidth of the transmitted signal, shown by $B = \frac{1}{\tau}$. Range resolution ΔR equation.

$$\Delta R = \frac{c\tau}{2} = \frac{c}{2B} \quad (2.12)$$

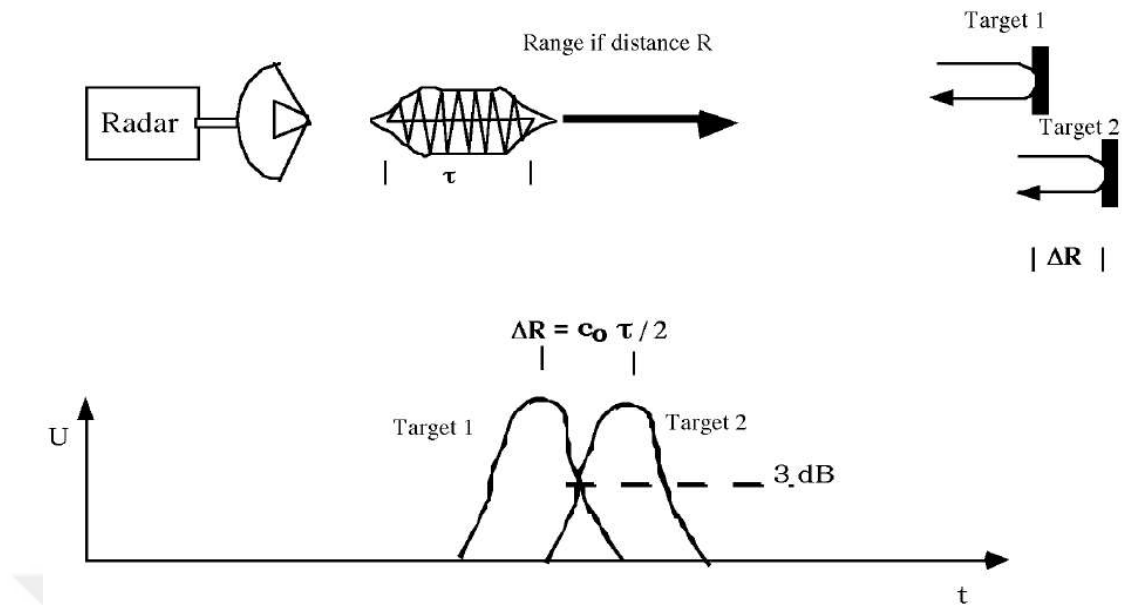

Figure 2. 3 Range resolution of two targets [20].

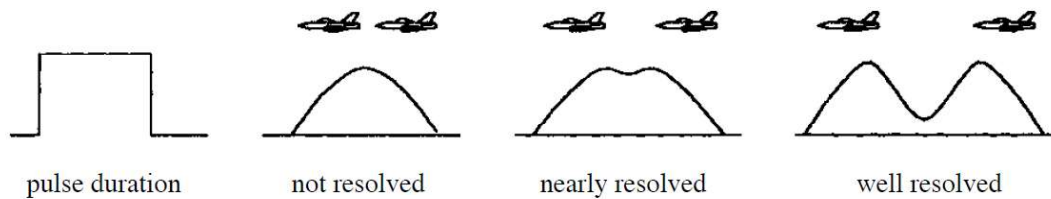

Figure 2. 4 Example for the ability to separate targets at different ranges [20]

Pulse width is the critical parameter for the range resolution. While transmitted short pulse width provide better range resolution but energy of the transmitted signal decrease due to lower peak power of the signal, increasing pulse width provide poor range resolution but energy of the pulse increased so getting more range. Distances between targets at the same range should be higher than half of the pulse width in order to be separated the targets by the receiver as seen in the Figure 2.3 and 2.4. When the distance between targets is not half of the pulse width, targets are seen like overlapped on the receiver. Target will be seen as a one waveform so receiver sense as an one target.

2.4 Radar Cross Section

Radar cross section (RCS) is a measurement of a target's ability to reflect radar signals in the direction of the radar. RCS is represented in the square meter (sqm) and affected by the transmitted frequency, shape of the object and the viewing angle of the antenna. Some RCS values is shown below table 2.1.

Table 2. 1 Typical radar cross section values [21]

Target	RCS (m ²)
Large commercial airplane	100
Large fighters	5-6
Small fighters	2-3
Man	1
Small bird	0,01
Bug	0,00001
F-117 fighter	0,1
B-2 bomber	0,01

RCS can also be defined a ratio of scattering power density to incident power density [4]. Intercepted power from the object is correlated with RCS and characterized by the σP_i (W). This intercepted power is absorbed as a heat or reradiated by the target to radar. Scattered power is isotropically in all 4π of space is

$$P_s = \frac{\sigma P_i}{4\pi R^2} \quad (2.13)$$

Let's find the RCS, is defined by σ , usually square meters, distance R from the target

$$\sigma = \frac{4\pi r^2 P_s}{P_i} m^2 \quad (2.14)$$

P_s : Scattered power density in the receiver direction [W/m^2]

P_i : Incident power density on the target [W/m^2]

Radar cross sections is not same as the physical area of the target. The cross-sectional area of the target radar is dependent on frequency, object geometry, target materials and the angular properties of the target and the direction of the radar viewed [6].

In principle, RCS can be decided by helping of Maxwell equations and the boundary conditions applied. Figure 2.4 shows backscatter from common shapes. The sphere

reflects isotropically electromagnetic echos in all directions and its of the RCS is equal to $4\pi r^2$ where r is radius of the sphere. Flat plate scatter waves back waves to radar perpendicular to target. The RCS of the flat plate is equal to $4\pi r^2/\lambda^2$. A tilted plate radiates away from the radar. The corner reflects directly back to radar as same as flat plate.

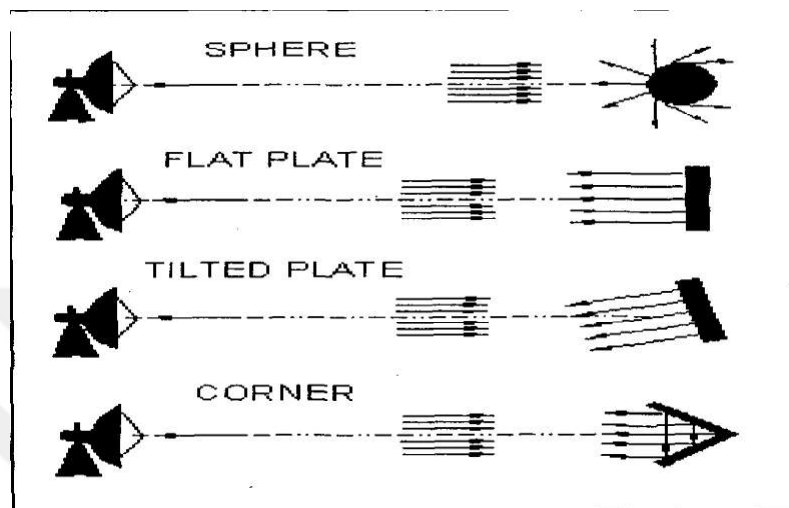

Figure 2. 5 Backscatter from objects having different shapes [22].

The region in which the sphere is tiny relative to the wavelength is known as the rayleigh region ($2\pi a/\lambda \ll 1$). Radius of sphere and wavelength are represented 'a' and λ , respectively. RCS areas of raindrops fall at frequencies in this region ($\lambda > a$) [23].

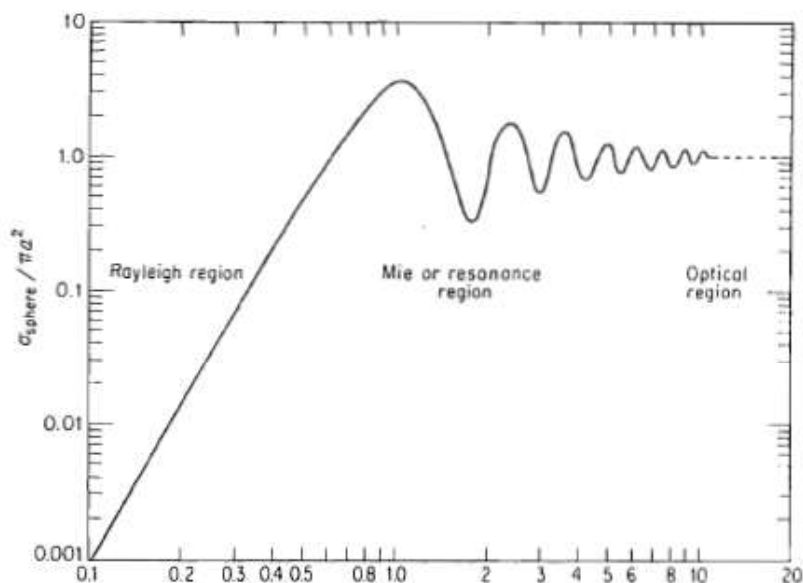

Figure 2. 6 RCS of the sphere

The size of the raindrops and other atmosphere particles is compared with usual radars is smaller than wavelength and this leads to invisible to radars for this particles. Weather radars should use high frequency range to achieve detection of raindrop reflections. At the other side of Rayleigh is the optical field, where the sphere dimensions are greater relative to the wavelength ($2\pi a/\lambda \gg 1$). For optical region, greater $2\pi a/\lambda$, RCS converges towards the optical cross section πa^2 .

2.5 Radar Frequencies

Traditional radars have been used at frequencies between 220 MHz and 35 GHz. Today, radars generally are operating at the millimeter wave. Limited frequency range is not existing for the radar and radar operations depend, but operations depend on the frequency range. Radars which have different bands show different capabilities rather than other frequency band [16-24].

Letter code like S, X, L, etc., were early used in the production of radar for designation of radar frequency bands. Although the initial goal was to preserve military confidentiality, the designations were kept, probably out of habit as well as the need for some convenient short nomenclature. This use has persisted and is now an accepted practice of radar engineers. Table 1.1 lists the radar frequency letter-band assigned by the International Telecommunication Union for radar. The place of radar frequencies in the electromagnetic spectrum is shown in Figure 2.7.

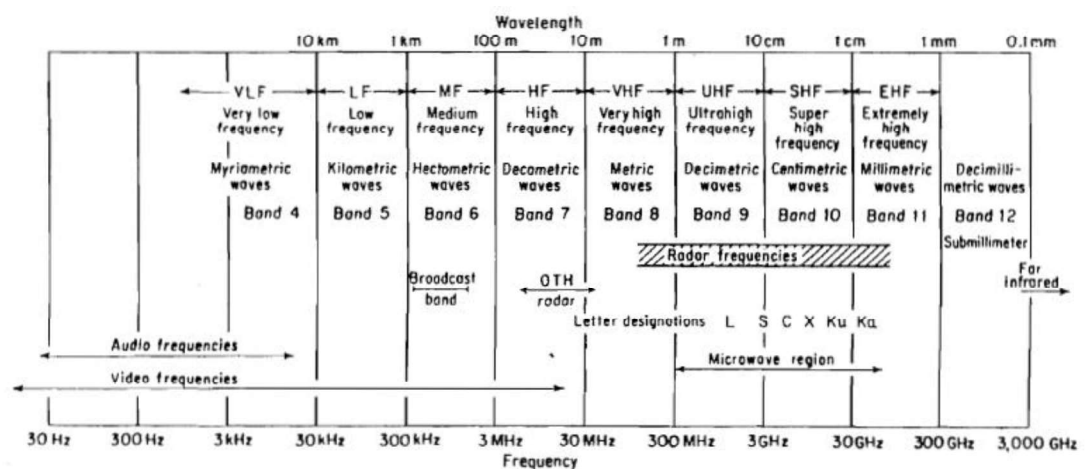

Figure 2. 7 Radar frequencies and the electromagnetic spectrum [4].

For example, although the nominal frequency range for L band is 1000 to 2000 MHz, an L-band radar is thought of as being confined within the region from 1215 to 1400 MHz since that is the extent of the assigned band. Letter-band nomenclature is not a substitute for the numerical frequency limits of radars. The specific numerical frequency limits should be used whenever appropriate but the letter designations of Table 2.2 may be used whenever a short notation is desired

Table 2. 2 Standard radar-frequency letter-band nomenclature [4].

Band designation	Nominal frequency range	Specific radiolocation (radar) bands based on ITU assignments for region 2
HF	3-30 MHz	
VHF	30-300 MHz	138-144 MHz 216-225
UHF	300-1000 MHz	420-450 MHz 890-942
L	1000-2000 MHz	1215-1400 MHz
S	2000-4000 MHz	2300-2500 MHz 2700-3700
C	4000-8000 MHz	5250-5925 MHz
X	8000-12,000 MHz	8500-10,680 MHz
K _u	12.0-18 GHz	13.4-14.0 GHz 15.7-17.7
K	18-27 GHz	24.05-24.25 GHz
K _a	27-40 GHz	33.4-36.0 GHz
mm	40-300 GHz	

2.6 Pulse Radar

Most radar systems are pulsed such as most airborne system, altimeter. Transmitter radiates pulse waveform to airspace in order to determine range of the target. Range of target is determined by time of flight of the pulsed signal.

$$\Delta R = \frac{cT}{2} \quad (2.15)$$

Transmitter power should be high to achieve a long range. During receiving the reflected signal, transmitter must be off in order to prevent signal leakage. Switch as called duplexer isolates the transmitter section from the receiver during the measurement. When the echo signal is received from the sensitive receiver, it is isolated from the transmitter.

When echo signals are obtained after second transmitted pulse signal, taken over the pulse repetition period, is defined by multiple time around echoes. It leads to

inaccurate distance measurement, called range ambiguity. One way to differentiate multiple time around echoes from unambiguous reflections are to work with a varying PRF. It should be solution for the multiple time around echoes. Another way rather than varying pulse repetition frequency can be differentiation of pulse amplitude, frequency or pulse width, but they are not so strong in practice. Low PRF is achievement way for unambiguous measurement of the target range but produce the velocity ambiguity. Low PRF is the trade-off for the range and velocity ambiguity. To avoid Doppler frequency ambiguity, high PRF is used but getting blind range. Compromise between range ambiguity and blind speed ambiguity can be achieved with pulse Doppler radar or MTI radar. MTI radars prefer to use low PRF to avoid range ambiguity but results in blind velocity. Pulse-Doppler radar is the good solution for the ambiguity in Doppler frequency but expose to blind range resolution so medium PRF (3 - 30 kHz) is used with the pulse Doppler radar.

Pulse repetition frequency is the number of the pulses transmitted per second towards to target. Pulse signals is transmitted as a periodic by the radar. The duration interval between rectangular shaped pulses is pulse repetition time (PRI) in the time diagram of the transmitter modulation as shown Figure 2.8. It is shown as a $1/f_r$ which is the inverse of it called as a pulse repetition frequency (f_r). Transmitted pulse width is denoted by τ .

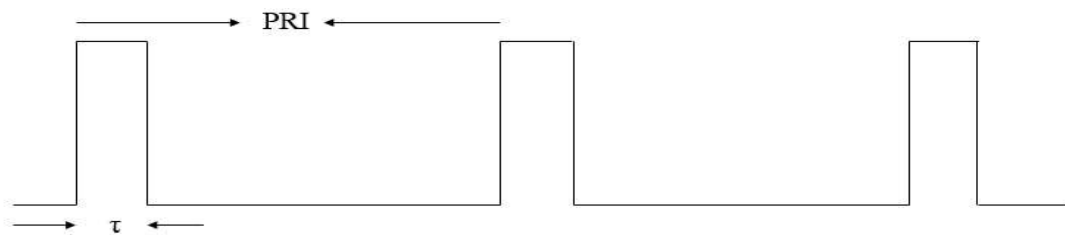

Figure 2. 8 Time diagram of the transmitter modulation.

The duty cycle or means that duty ratio is the ratio of the transmitted pulse width to pulse repetition interval (periodic time) on time.

$$\text{Duty cycle} = \frac{\tau}{T_r} = \tau f_r \quad (2.16)$$

The energy of the pulse signal is the

$$E_t = P_{pk} \tau = P_{av} T_r \quad (2.17)$$

where P_{pk} : Peak pulsed power

τ : Pulse width

T_r : Pulse Repetition Interval (PRI)

Obtaining power average is

$$P_{av} = P_{pk} \frac{\tau}{T_r} = P_{pk} * \text{duty ratio} \quad (2.18)$$

Since the transmitter is off during the receiving, the pulses radar does not continuously radiate, the average power is marginally lower than the peak power so average power is measurement of the radar system capability. If the transmitter output power is high, greater range could be achieved with the amount of the energy in this waveform. Average power is obtained by the peak power multiplied with the duty ratio of the pulse waveform. In order to maximize range, there are different ways of the increasing average power by extending the PRF, pulse width and the peak power. The energy of the signal is related to the width of the pulse. The energy of the signal is the pulse width multiplied by the peak power of the pulse waveform. Greater pulse width, getting the maximum range is increased.

Since wider pulse contains more energy, the greater the transmitter power enable higher range capability reception. Greater average power is obtained with wider pulse widths.

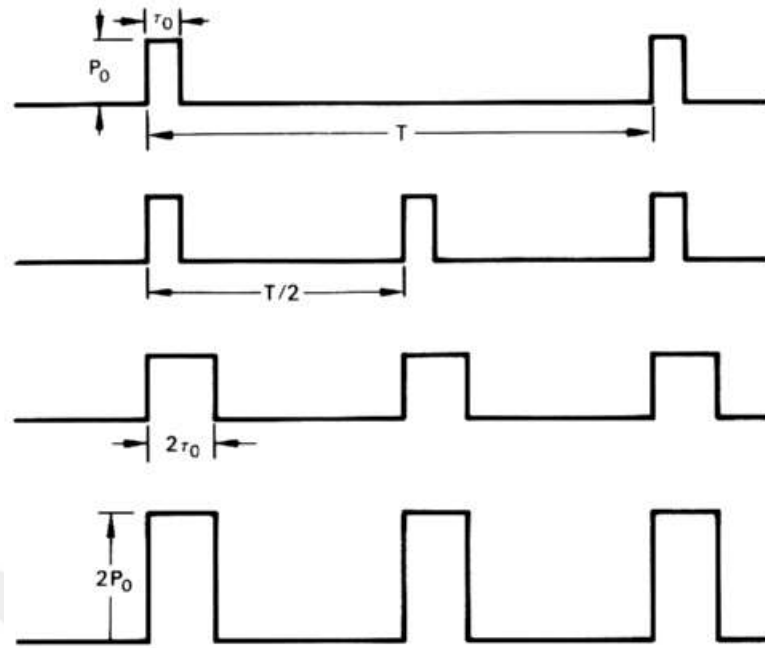

Figure 2. 9 Three ways of increasing average power.

In a radar system, power of the echo signal can be about picowatt, on the other hand, transmitter power can be megawatt. Repetitive train of short pulses is generated by modulating of the carrier sine wave with amplitude shift technique. Leading edge of the pulse signal is the reference for the starting measurement of time between radar and target. The measurement is completed with the rising edge of the pulse shaped signal. The most important feature of pulse radar is the time controller. Synchronizer generates trigger pulses, timestamps and switching gates to determine starting point of the waveform generator. The transmitter may be a power amplifier, such as the Klystron, travelling wave or transistor or power oscillator, such as magnetron which is used in early radars [25]. A pulse modulator turns on and off in synchronism with the input pulses, when a power oscillator is used, it is also turned on and off by a pulse modulator to generate a carrier pulse waveform [25]. Waveform generator produces radar signal with pulse modulator which turn on/off amplifier for producing pulse waveform, as seen block diagram in Figure 2.10. Transmitted waveform signal is given mathematically below equation 2.19.

$$S(t) = A(t) \times \sin [2\pi f(t) \times \phi(t)] \quad (2.19)$$

$A(t)$ function describes the transmitter on/off. If switch is on, $A(t)$ is 1 or means that carrier signal is transmitted and transmitter is 0 W with $A(t)$ 0 when receiver is sensitive to radar signal. It is a simple form of amplitude shift keying (ASK) modulation. The phase modulation $\phi(t)$ provides the required phase characteristics of the modulated signal [26]. In the phase modulation, phase of the radar signal is changed by phase shifter after amplitude modulation.

Pulse radar system transmit pulse shaped of the EM waves to target. In pulse radar technique, range measurement can be simplified. If the pulses are sufficiently separated, range of the target can be precisely determined merely by measuring the elapsed time between the transmission of a pulse and the reception of the echo [23]. Receiver is isolated from the transmitter via duplexer during the transmission but after transmission, transmitter is isolated from the receiver until next pulse send out. It provides many advantages that protects receiver from high voltage during the transmission on the monostatic antenna system.

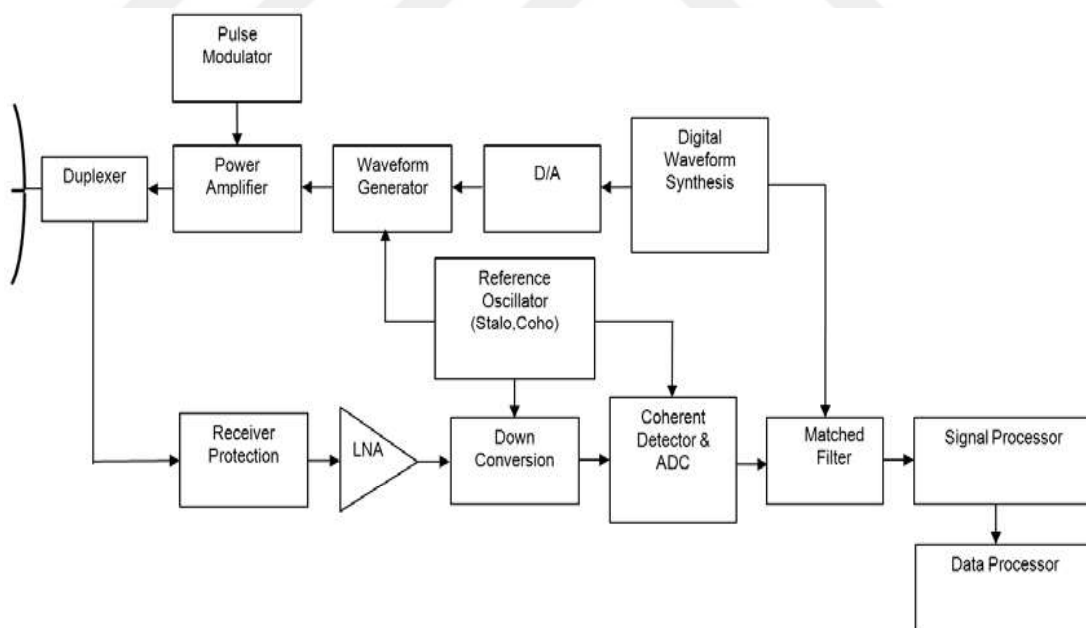

Figure 2. 10 Pulse Radar System.

Duplexer isolates the transmitter from the receiver system. In the superheterodyne receiver section, Low noise amplifier (LNA) is employed in figure [2.8]. LNA is to amplify weak signals, increasing SNR by minimizing noise. LNA increasing gain of

the signal with the minimum noise in the receiver. Receiver is heterodyned with the reference oscillator in the Figure 2.8. Coherent detector is used for the phase detection with reference oscillator. Match filter is used to achieve the SNR and obtained transmitted signal in the additive white Gaussian noise. Received signal is processed in the signal processor section in the receiver of the radar.



CHAPTER 3

SYSTEM DESIGN AND VERIFICATION

3.1 Transmitter Subsystem

3.1.1 HB100 X-Band microwave motion sensor

HB100 series of microwave motion sensor module are X Band Mono static Dielectric Resonator Oscillator (DRO), Doppler transceiver front-end module as shown in the Figure 3.1. HB100 module is consisted of mixer, DRO and patch antenna as seen in the circuit design. This microwave motion sensor module is shown at the Figure 3.1. +5V Dc voltage is supplied to run for CW operation. This sensor also can be operated by +5V low duty cycle pulsed trains in order to decrease its power consuming. Power of the sensor and radiated frequency is constant because it is fixed by the factory so adjustable section is not required.

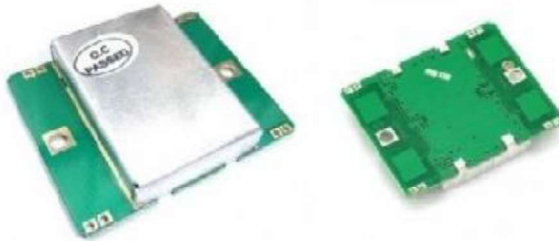

Figure 3. 1 HB100 Doppler sensor module.

Table 3. 1 Sensor Specifications.

Parameter	Min	Typ	Max	Units
Frequency Setting	10.520	10.525	10.530	GHz
Radiated Power (EIRP)	12	15	20	dBm
Received Signal Strength		200		μ Vpp
Noise		5		μ Vrms
Antenna Beam-width Azimuth		80		°
Antenna Beam-width Elevation		40		°

HB100 module is able to detect single objects with continuous wave. These modules can be used for intruder alarms, movement detection and measuring speed of the target. This motion sensor can detect objects to a range of up to 20-25 meters with radiated frequency is about 10.525 GHz. These modules consist of patch antenna, mixer and dielectric resonator oscillator (DRO). Dielectric resonator oscillator is used as an internal signal generator. Transmitted signal generated from the oscillator sent by patch antenna and also local oscillator is used with mixer. At the same tuned specific frequency, it operates in the bi-static Doppler radar module. Signal generated from the oscillator and echo signal mixed in the mixer. After the mixed signal, difference frequency between oscillator and received signal is sent to IF section on the module. IF output of the module is connected to high gain low frequency amplifier in order to get processable level for the Doppler shift.

Radiated power of the microwave sensor is the minimum level of 12 dBm and maximum level of 18 dBm. Sensitivity is the minimum signal, receiver can detect and process. This microwave motion sensor has -86 dBm sensitivity and 10 dBi gain. In addition to this, microwave motion sensor has typically elevation degree about 40° and azimuth degree about 80°. Microwave motion sensor circuit schematic and radiation pattern is given below Figure 3.2 and 3.3, respectively.

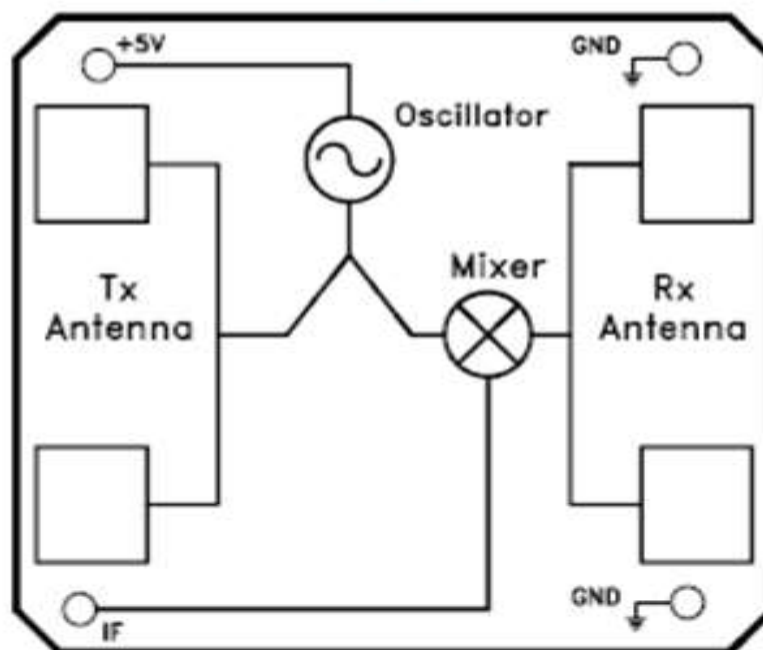

Figure 3. 2 The schematic of the HB100 microwave sensor.

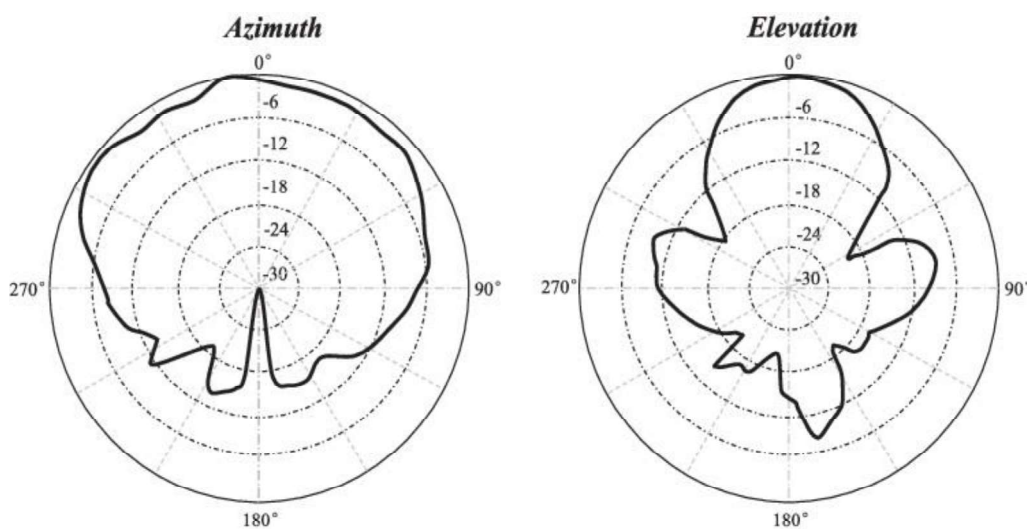

Figure 3. 3 Radiation Pattern.

Doppler shift is detected in the IF when stationary object moves. Received output of the module is in the range of μV . Doppler shift output energy is proportional to

scattered of transmitted energy. In order to get processable level from the output of the IF terminal, high gain low frequency amplifier should be used. Human movement occurs Doppler shift below 100 Hz. Beneficial capability for separating the reflected signal from the transmitted signal as there is relative change between radar and moving object depend on recognizing change in received signal frequency caused by Doppler shift. Frequency shift in Doppler effect depend on velocity of the target or radar. For example, if a train close or recede from the observer, frequency change will result in. If the object is approaching to radar, reflected received signal will be $f_t + f_d$ or target getting away, Doppler frequency will be negative, $f_t - f_d$. It is the basis of CW. In the below figure 3.4, Doppler shift is shown, and Doppler equation is given

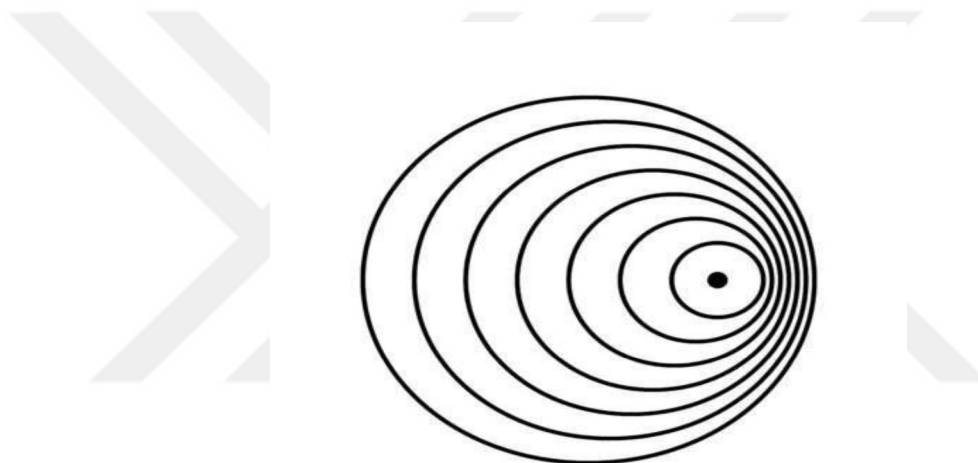

Figure 3. 4 Doppler effect.

$$F_d = 2V \left(\frac{F_t}{c} \right) \cos \theta \quad (3.1)$$

F_d = Doppler frequency

V = Velocity of the target

c = Speed of the light (3×10^8 m/s)

θ = The angle between the object moving direction and the axis of the sensor

93 dB total loss occurs between received signal and transmitted microwave signal from the module, caused by the target and free space loss as well as other losses leads to

loss total of 93 dB. Received signal strength (RSS) can be used as a signal strength estimate for a person 15 meters away, who walks directly to the module at 1.28 km/hour. Human body reflection varies with body height, cloth, apparel and other environmental factors. For two human bodies, measured RSS can differ by 50%. Outer effects such as surrounding cause noise rather than of inside of electronic circuit.

3.2 Receiver Subsystem

3.2.1 Low Noise Block Downconverter

Low noise block downconverter is a device that a critical part of the receiving end of a satellite communication system and mounted on parabolic dish antennas and commonly used for the satellite TV as an example Figure 3.5 given below [27-28]. High frequency signals traveling from the satellite, reach to the focus of the antenna and reflect from the surface of the dish antenna to LNB. Antenna is used a passive device here. The coming signal from the dish antenna, firstly, obtained corrugated horn antenna and propagates down the waveguide of the feedhorn and entering into a rectangular chamber mounted at the front of the low noise block downconverter (LNB), in which a tiny resonant probe is located in [28-29]. This probe provides to conduct signal moving into the first level of electronic amplification. With amplifying the received signal from the satellite, the thermal noise is produced in the first level of electronic amplification. Received signal is amplified with internal minimum noise caused by the LNB.

LNB is consisted of mixer, low noise amplifier and IF amplifier. LNB is the first active element to operate on high frequency signals coming to the focal point of the antenna. Microwave signals collected from the dish is weak signals, so these signals are amplified by low noise amplifier and downconverted the block of frequencies to lower block of the IF frequency with mixer section. Downconverted signals is send to indoor satellite TV receiver with coaxial cable but coaxial cable attenuate the signal about 10-20 dB between LNB and indoor satellite receiver. It depends on quality of coaxial cable and length of the cable. After downconverting signal to block of 975-2150 MHz frequencies, IF amplifier is used to strength the signal for cable loss.

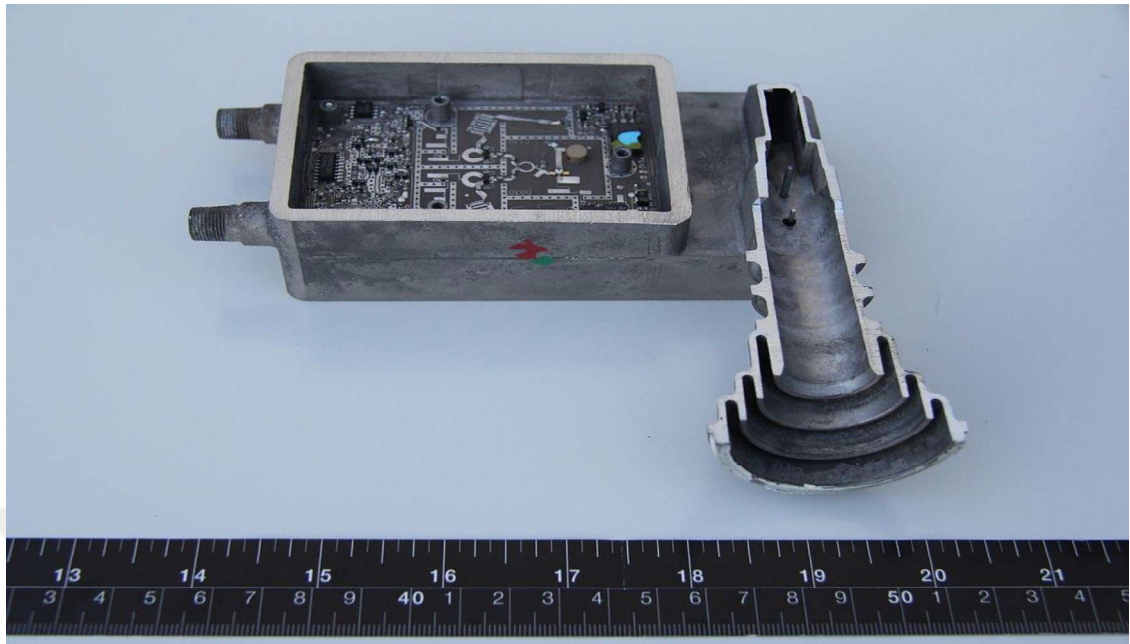

Figure 3. 5 Low Noise Block Downconverter [30].

3.2.1.1 Feedhorn

Reflector dish antenna reflect satellite signals to focus point of the antenna. Feeder is mounted on the front of the LNB. It is task of the feedhorn to collect the signal that comes in the vicinity of the focal point and conduct it on to the receiving system's first stage of the amplification [31]. It is designed that unwanted signals or noises from the environment are rejected out with waveguides. Signals is gathered by the feeder from the dish antenna which collects microwave signals to focal point between 4-21 GHz and signals is fed to a section of waveguide [31]. LNB and feedhorns is a single unit and positioned on the front of the reflector antenna is called LNBF. LNBF is consisted of feedhorn and polarizer with LNB. After signals coming from the satellite is picked up by the feedhorn, fed to waveguide for the polarization. There are horizontal and vertical probes inside feedhorn. These probes, horizontal or vertical, resonate with the incoming polarization signal and transmit the signal to the inside of the LNB to amplify signal. Power supply (13 V or 18 V) determines the polarization of the signal by adjusting probes.

3.2.1.1.1 Polarization

Satellite TV signals can be polarized because it enables a way of sending more TV channels using a given frequency band. This approach needs the use of receiving equipment that can filter incoming signals based on their polarization. On the same frequency, two satellite TV signals can be transmitted and provided that these signals are polarized differently, the receiver can separate them and display whichever one is currently required [29-31]. Power supply voltages is used to determine the vertical or horizontal polarization for a universal LNB. 13V (vertical) or 18V (horizontal) supply is used to choose polarize signals by activating switch before the signal amplification. This DC power is normally supplied from the indoor satellite receiver. Waveguides (generally WR75-WR90) inside LNBF is used to polarize satellite signals for vertical or horizontal signals. LNB polarization table is given at the Table 3.2.

Table 3. 2 LNB Polarization.

Supply Voltage	Polarization	Frequency Band	Local Oscillator Frequency	IF Range
13V	Vertical	11.70–12.20 GHz	10.75 GHz	950-1,450 MHz
18V	Horizontal	11.70–12.20 GHz	10.75 GHz	950-1,450 MHz
13V	Vertical	3.40–4.20 GHz	5.15 GHz	950–1,750 MHz
18V	Horizontal	3.40–4.20 GHz	5.15 GHz	950–1,750 MHz

3.2.1.2 Single Band LNB

When we need to specify the LO value (or values) of the LNB, we use software in the receiver. Single Band LNB allows to one channel by feeding only a single receiver. It has only one oscillator.

3.2.1.3 Dual Band LNB (Universal LNB)

Two different switchable local oscillator frequency is used for dual band LNB. Local oscillator frequencies can be switched between different values because some frequencies fall outside the L band frequency range which satellite TV receiver operates. Broadcasts in the range of 10.70- 11.70 GHz use the frequency of 9.75 GHz LO, while broadcasts in the range of 11.7- 12.75 GHz use the frequency of 10.6 GHz LO. 22 kHz signal sent by the receiver to LNB, switching technique is used by selecting LO frequency for the band selecting. This allows to show different TV channels with more receiver. In addition to this, 13V-18V supply voltage is used to polarize signals (vertical or horizontal) in the Ku band satellite.

Table 3. 3 Dual band LNB.

Supply		Block		Local oscillator frequency	Intermediate frequency range
Voltage	Tone	Polarization	Frequency Band		
13V	0 kHz	Vertical	10.70-11.70 GHz, low	9.75 GHz	950-1,950 MHz
18V	0 kHz	Horizontal	10.70-11.70 GHz, low	9.75 GHz	950-1,950 MHz
13V	22 kHz	Vertical	11.70-12.75 GHz, high	10.60 GHz	1,100-2,150 MHz
18V	22 kHz	Horizontal	11.70-12.75 GHz, high	10.60 GHz	1,100-2,150 MHz



Figure 3. 6 LNB PCB Board [30].

3.2.1.4 Low Noise Amplifier

Satellite signals get attenuated until they reach the dish antenna. Before downconverting signal process, these signals should be amplified. LNB includes low noise amplifier to amplify weak signals, collect by the LNB. Low noise amplifier amplifies low power signals adding little noise to the signal above the noise floor (NF). NF of the ideal LNA should be 0 dB and 1 dB which is good for a LNA. Its basic function is to amplify received weak signal with minimum distortion. To achieve this, the NF should be minimal, and its level depends on manufacture tolerances so NF can be different for every LNB production. The main signal will be amplified generally between 46-65 dB gain. The LNB get its power to operate from the indoor satellite box with coaxial cable carries signal.

3.2.1.5 Block downconversion

High radio frequencies is transmitted to earth by the satellite for TV broadcasting. The dish antennas is positioned on the outdoor because of these signals would not pass walls or roofs. Microwave signals reaching to LNB are between 10.7 GHz and 12.75 GHz. These high frequencies should be downconverted to L band range of frequency

(950-2150 MHz) for processing. These lower frequencies would be sent through coaxial cables with less attenuation.

After attenuated high frequency satellite signals is amplified at the LNA, these high frequencies should be converted to lower frequencies for processing at the indoor satellite receiver. Intermediated frequency is called lower frequency difference between fixed local oscillator frequency and coming frequency. Local oscillator (LO) frequency is that produced from dielectric resonator oscillator inside of the LNB and received signal is mixed for the IF. Mixed frequencies are summing of the frequencies and difference between local oscillator frequency and satellite frequency. After getting intermediate frequency, filter process is applied to select lower frequency. Finally, lower frequency is amplified with IF amplifier and set down to coaxial cable for indoor satellite receiver.

LO inside the LNB produce a constant frequency. Local oscillator frequency changes according to block of incoming signal and what block of satellite frequencies is opted by the local oscillator downconverted to the frequencies for the receiver. For example, LNB local oscillator frequency operates differently in satellite frequency in the range of C and Ku band. Astra 2A and 2B use frequency range of 11.70-12.75 GHz. A local oscillator frequency of 10.60 GHz is used to downconvert Astra satellite frequency downconverted to range of frequency 1.100-2,150 MHz for receiver's IF tuning range 950-2,150 MHz. On the other hand, Astra 1KR transmit frequency range of 10.7-11.7 GHz so 9.75 GHz local oscillator should be used generate block of 950-2,150 Mhz for the European receiver IF tuning range. Generated IF frequencies between 950-1950 MHz are in the European receiver band of tuning range.

In the C band, transmitting frequency range 3.7-4.2 GHz which is lower than the local oscillator frequency and requiring local oscillator frequency of 5.150 GHz. IF will be in the L band frequency range of 950-1,450 MHz which is difference band rather than others. It will reject higher band (8,850-9,350 MHz) by the filter.

3.2.2 Analog Satellite Finder

The satellite finder provides connection between the LNB and the satellite receiver for quick and simple setup of the satellite dish antenna. Satellite dish is a dish-shaped type of reflector antenna setup for collect signal of the communication satellite. Satellite finder demonstrates strength as the satellite alignment is adjusted, both vertically and horizontally, to find the strongest possible signal. Satellite finder is a meter which connects in-line with LNB, supplied by indoor TV receiver, which shows the signal energy in the L band frequency range or LNB IF section. Our signal strength meter measures the amount of RF energy over a wide spectrum of frequency range by integrating the power from all transponders and generating RSS indicator output, by means of proportionate DC voltage. Maximum and minimum input power of this satellite finder is -10 and -40 dBm. Diode detector in the circuit leads to 6 dB loss and non-inverting opamp circuit leads to greater gain output power level. Diode detector and opamp in this signal strength meter detect RF power by means of DC output voltage.

The circuit of the satellite signal meter is shown below [6]. The IC 78L10 voltage regulator convert DC obtained from the LNB itself to 10V regulated output for supply the non-inverting opamp. L1 inductor isolate RF input signal passing into the the circuit in order to reduce signal loss and unnecessary interferences. 39pF capacitor coupling the RF signal obtained from the LNB and decouple the DC from the sensor stage.

The silicon fast recovery high speed diode network formed by the two 1SS99 Schottky diodes rectify the obtained RF signals into observable DC signal. L2 inductor allows coupling DC signal to sensor stage but 1 nF capacitor grounded because unwanted AC signal leakages.

RF signal is coupled to noninverting input of the opamp which is configured as a high gain. Gain of the signal is adjustable with feedback pots so that the circuit can be tuned to provide higher sensitivity and to achieve the lowest possible signal from the LNB.

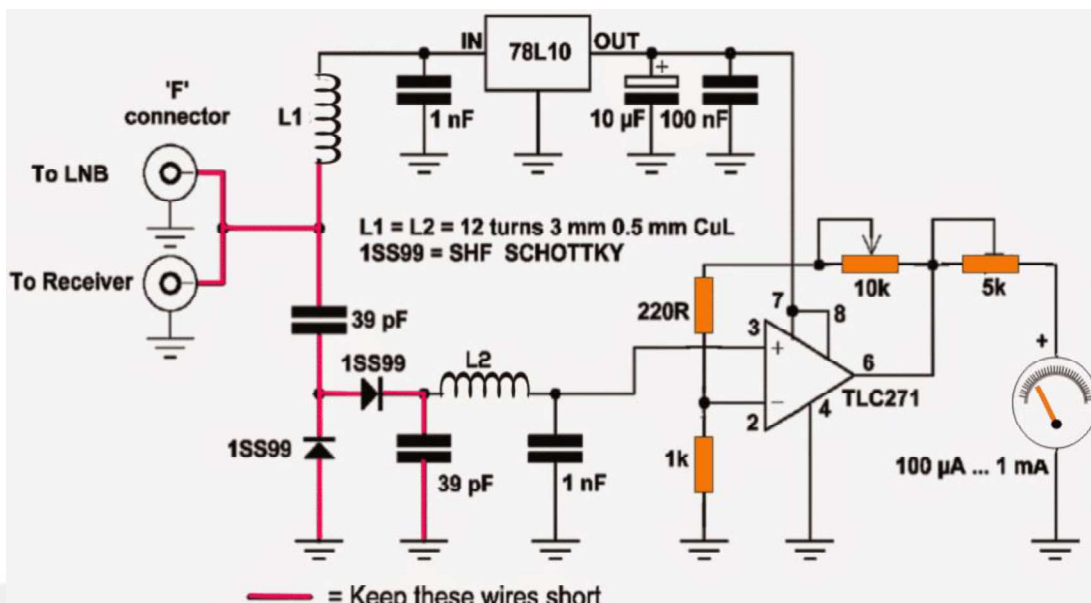

Figure 3. 7 The circuit design of the satellite finder [6].

3.3 System Verification

This section deals with power calculations which need to be take into consideration when designing radar system, is supported by test modules and system design. Also, pulse radar system development is explained in detail.

In this simplified model, development of the system, given in the Figure 3.8. Function generator drives a microwave motion sensor which generates pulse waveform directly. Square wave or pulse waveform can be get from the function generator using TTL output or signal output.

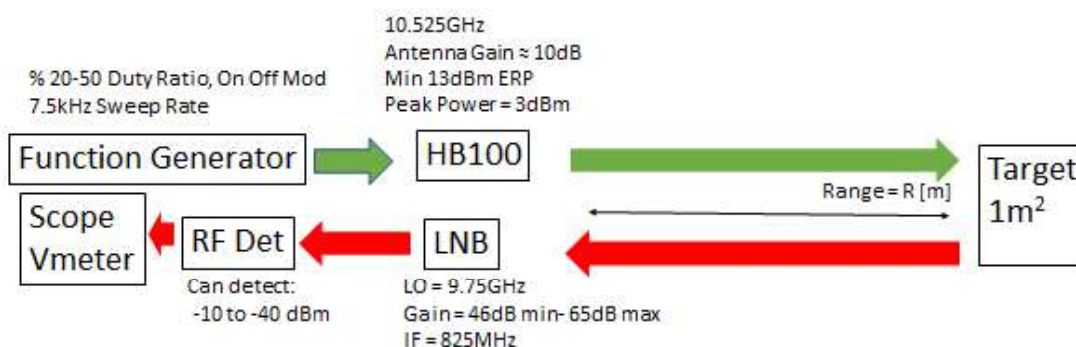

Figure 3. 8 System design schematic.

HB100 microwave motion sensor gives output of continuous wave operation with + 5V DC supply. Its output depends on the input waveform of the microwave motion sensor. If it is operated with typically +5V dc power supply, function of the of the sensor will be continuous waveform. TTL output of the function generator or square wave can drive the microwave motion sensor with enough peak-to-peak voltage level. Sensor generates pulse waveform output or we can say that input supply of the microwave sensor is modulated by the square waveform or TTL output of the function generator.

TTL is the logic family composed of bipolar junction transistors. Transistor to transistor logic circuits which is the type of digital integrated circuits, use like NAND, NOR logic gates. TTL inputs employed multiple emitters. Ideally, in the function generators, TTL high output level is 5V or other means that TTL output of the function generator generates exactly constant 5V square wave (high logic state) with the 2-5V input or else low logic state for 0-0.8V

Normal output of the function generator produces signal with varying amplitude. For example, if you set the function generator for 1kHz, 4.75V peak-to-peak sine or square wave, output of the function generator produces same input signal, generate 4.75V sine or square wave at the 1 KHz. Signal frequency or signal amplitude can be swept for the normal output.

HB100 microwave motion sensor module operates at the 10.525 GHz. It consisted of dielectric resonator oscillator (DRO). Oscillator which is used in the HB100 sensor module, dielectric resonator which is the frequency determining element. It is used to generate signal with good stability. Physical dimensions of the dielectric material determine the resonant frequency is produced by the DRO. Frequency of the DRO is the fixed but adjusting the resonant frequency can be accomplished with mechanical tuning. It also can be achieved with electrical or varactor tuning.

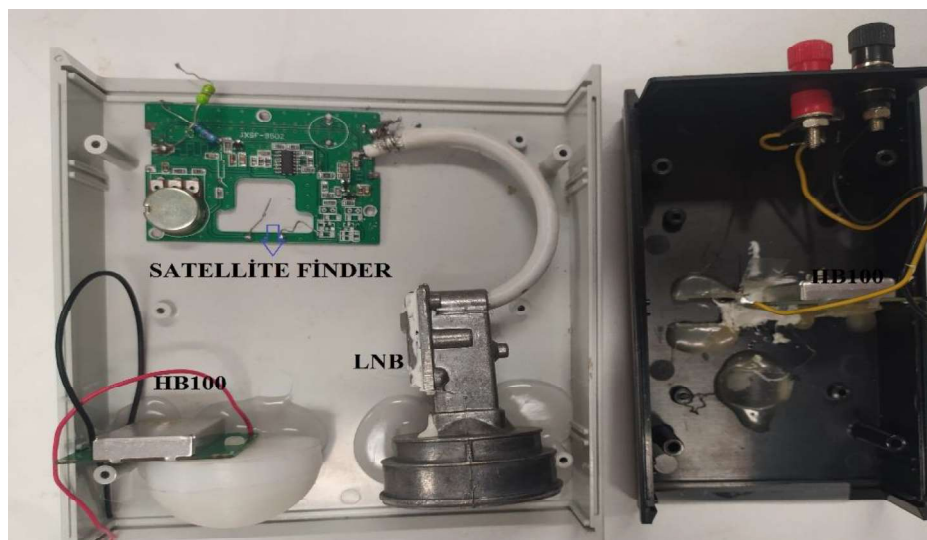

Figure 3. 9 Transmitter and Receiver.

HB100 microwave motion sensor radiates waveform power level of between 12-18 dBm. In the transmitter section of the radar system, GW-INSTEK SFG-2110 function generator is used to modulate the input of the sensor. +5V input of the sensor is modulated by the square wave or TTL output as a defined on-off keying (OOK) technique which is the special case of Amplitude Shift Keying (ASK). ASK is clearly described with equation 2.19. Power should be between 4.75-5.25V to operate the module. It results in continuous waveform at 10.525 GHz. If power is given above maximum limit, the sensor could be burn-off. HB100 radar module sensitivity is the 200 μ V which corresponds to -64 dBm. HB100 microwave motion module sensor can not detect signal below power level of -64 dBm.

In this study, module is feed with minimum 4.75V and maximum 5.25 V in order to operate. Dielectric resonator oscillator is directly coupled with input of feeding. DRO generates CW signal with +5V DC supply. In this research, +5V input of the module is modulated by the pulse wave or square wave with 10.525 carrier frequency. Pulse modulated CW radar is a type of amplitude modulation. Modulating pulse and RF carrier signal is shown below Figure 3.10 and 3.11, respectively.

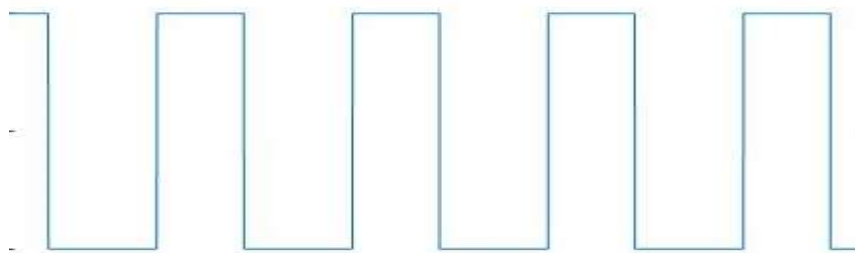

Figure 3. 10 Modulating Pulse.

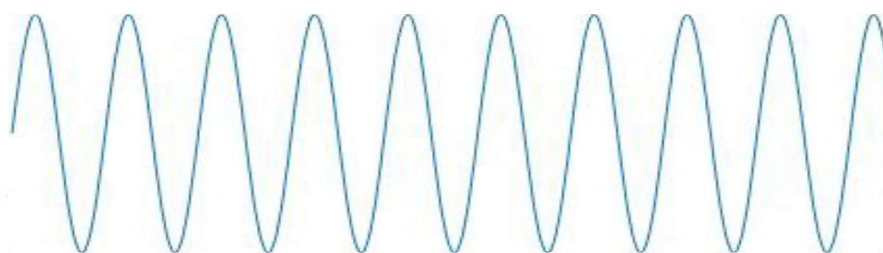

Figure 3. 11 RF carrier.

Function generator generates periodic train of pulses as given Figure 3.10. When square wave is “on” cycle, the module operates, but when square wave is “off” cycle, the module is off mode because of the required supply power of the module. Modulated RF carrier signal is shown below Figure 3.12. Pulse wave amplitude is about 5V and modulation frequency and duty ratio is tunable in the function generator.

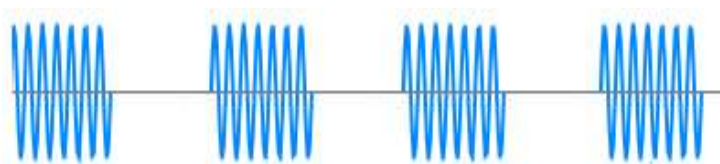

Figure 3. 12 Modulated CW signal.

The basic concept of the modulating pulse is shown the Figure 3.13. The carrier signal frequency is 10.525 GHz. Pulse width is 2ms and pulse repetition interval is 10 ms or means PRF is 100Hz and duty ratio is %20.

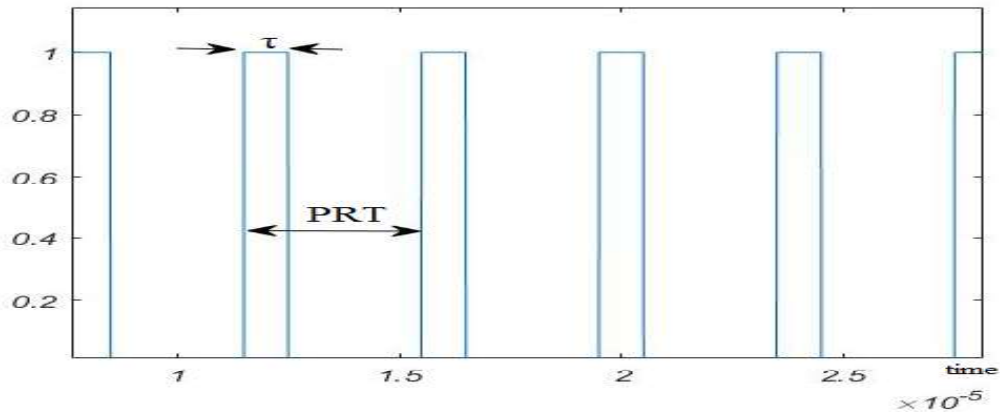

Figure 3.13 The basic concept of the modulating pulse.

Pulse radar has a capability to measure the range of the target. Distance measuring needs time reference for a radar system. In the pulse radar system target measuring can be calculated with below formula.

$$R = \frac{c\Delta_t}{2} \quad (3.2)$$

Signal propagates at the light speed of 3×10^8 (c) through the free air. Δ_t defines the time of flight between the radar and target. Distance must be half of the speed of the waveform times period since signal takes two way between the target and the antenna. Also, range depends on the pulse width. If the pulse width increases in the waveform, average power of the transmitted signal will be improved so increasing measuring range could be succeeded. On the other hand, range resolution will be poor with increasing pulse width because echo signals are overlapped so it is difficult to separate them.

In this experimental study, RCS of the metal sheet was used about 1 m^2 . The target was placed about 10 meters from the radar due to limited laboratory conditions and exist clutters due to conditions in laboratory. Setup system is given below Figure 3.14.

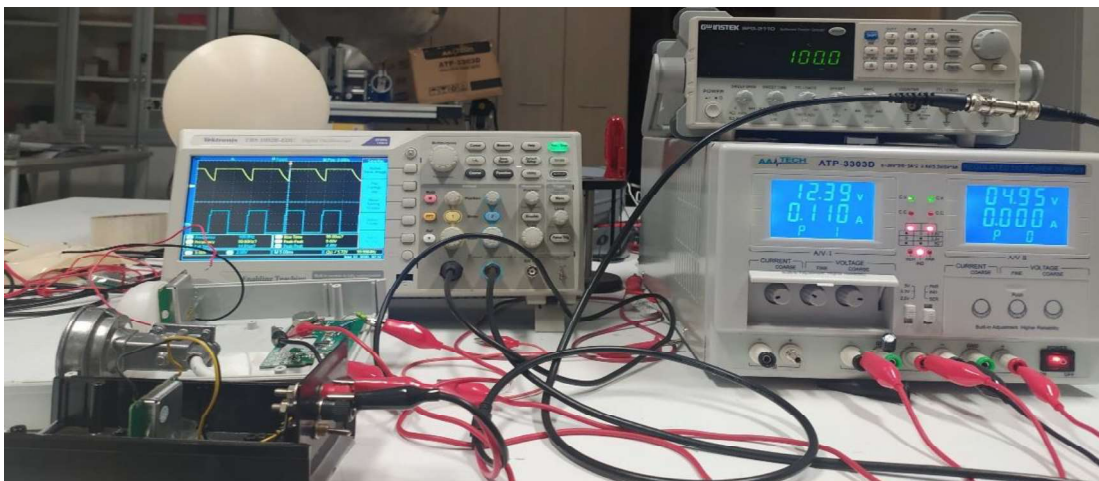

Figure 3. 14 System setup.

Receiver section is consisted of the LNB and satellite finder. Tektronix digital oscilloscope which is used in the experimental study. It has 50 MHz bandwidth. Echo signal can not directly be seen on this oscilloscope due to limited bandwidth, so it needs to be downconverted low frequency and demodulated. LNB downconverts the high frequency signal to low frequencies. Echo signals pass through the feed horn before the amplified signal. Feedhorn is placed at the front of the LNB used to select signals. Waveguide in the feedhorn select polarized signals with resonance probes according to echo signal so unwanted signals is rejected. WR-75 flange is used in the waveguide of the feedhorn.

Feedhorn section is consisted of the corrugated horn antenna and rectangular waveguide. 13V DC supply to LNB provides to select vertical polarization signals. Feedhorn antenna have low gain about 5-6 dBi due to open-ended waveguides.

After corrugated transition to rectangular waveguide, received echo signal should be downconverted to low frequencies for signal processing. Low noise block downconverter circuit schematic given below the Figure 3.15. Bandwidth of the LNB is about 2 GHz.

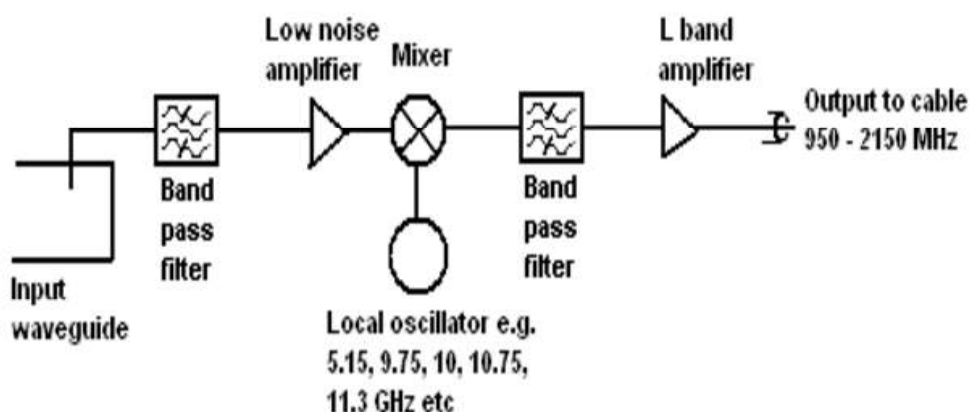

Figure 3. 15 Schematic of the Low Noise Block Downconverter [32].

In the LNB, received signal which passed through feedhorn and after enter the inside of LNB, exposed to filter processing through bandpass filter. Bandpass filters pass the determined range of frequencies so reject noise signals from the environment and followed by the LNA.

LNA amplify weak received echo signals and amplifies received attenuated signals without much reducing its signal-to-noise ratio. Attenuated echo signals are amplified about 20 Db by the LNA. Noise figure of the LNB will be less than 1 Db. LNA is followed by the mixer.

In the mixer stage, echo signal about 10.525 GHz is mixed with local oscillator signal. Human movement is ignored because it is below 100Hz and oscilloscope can not display these shifting frequencies after demodulation pulse signal. Local oscillator frequency is 9.75 and 10.6 GHz. LO frequency is selected using 22 kHz signal with coaxial cable is connected output of the LNB but LO frequency is automatically fixed to 9.75 GHz in the study. IF, output of the mixer, will be 10.535 ± 9.75 . IF output of the LNB will be 500-950 Mhz.

Lower sideband and upper sideband signals occur at the output of the mixer. Bandpass filters pass the lower sideband signals and rejected upper sideband. It is followed by the IF amplifier. IF amplifier amplify downconverted RF signal. Conversion gain of the universal LNB is the about 46-65 dB.

Satellite Finder is connected to the output of the LNB with coaxial cable. It indicates the signal energy which received echo signal, will be range of 500-900 MHz. Satellite finder would be thought as a power detector. It also adjusts gain of the demodulated received signal for sensitivity of the echo signal. TLC271 op-amp is powered with regulated 10V by the DC power supply. In the front-end receiver system, LNB and satellite finder is supplied from the output of the satellite finder.

When amplitude modulation is used in the non-coherent system, for example, on-off keying (OOK), the demodulation could be just an envelope detector or rectifier [33]. Envelope detectors are required to obtain the amplitude of the signal in a great variety of circuits, mainly for gain control systems [34]. Envelope detectors convert RF signals into current and output envelope detector follow the low pass filter [35]. Echo signal is rectified to remove carrier signal with envelope detector and followed by the lowpass filter for smoothing.

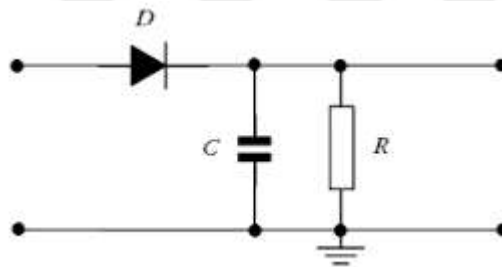

Figure 3. 16 Envelope demodulator circuit.

Envelope detector removes the carrier frequency of the pulse received signal and extracted the envelope signal or DC signal.

$$x(t) = s(t) \cos(\omega t + \vartheta(t)) \quad (3.3)$$

where $\omega(t)$ is the carrier frequency, $\vartheta(t)$ phase, $s(t)$ message signal.

$$x(t) = (C + m(t)) \cos(\omega t + \vartheta(t)) \quad (3.4)$$

message frequency is symbolized by $m(t)$ and C is the amplitude of the carrier frequency.

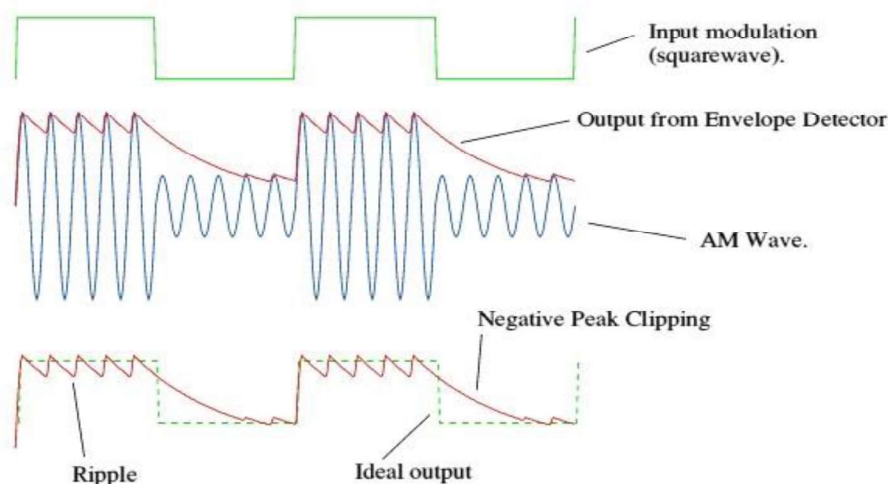

Figure 3. 17 Amplitude Demoduation [65].

In the Figure 3.7, 39pf capacitor allows the RF signal from the LNB to satellite finder. In this study, envelope detector is used as a power detector. Envelope detector is consisted of schottky diode and capacitor as shown Figure 3.16. Schottky diode is less forward voltage drop than conventional silicon pn-junction diode, so they have faster switching mode at the lower turn-on voltage. Schottky diode rectifies the signal and charges the capacitor to the peak voltage of the received AM wave, as seen in the Figure 3.17. If received power increase, the capacitor voltage is increased via the rectifying diode. While amplitude of the input signal is decreasing, capacitor voltage falls by discharging. As seen in the Figure 3.17, there are some problems as negative peak clipping and ripple because of the small discharging time between peak levels of the input signal. Envelope detector is followed by the lowpass filter. Drawback of the envelope demodulator is the loss of phase of the received signal and not possible to detect Doppler frequency. Lowpass filter is required to smooth the ripples on the envelope follower output after demodulation.

Finally, non-inverting amplifier IC TLC271 op-amp is used as a high boost amplifier mode and given a non-inverter feedback amplifier in the Figure 3.18. In the non-inverting amplifier, DC signal coupled to non-inverting terminal and amplified at the output. The feed back pots are used to control the gain of the demodulated signal. Gain circuit can be tuned to adjust the sensitivity. Potential divider network provides to determine gain for input signal in the non-inverting pin of the op-amp. Voltage gain of the non-inverter circuit is given equality 3.5.

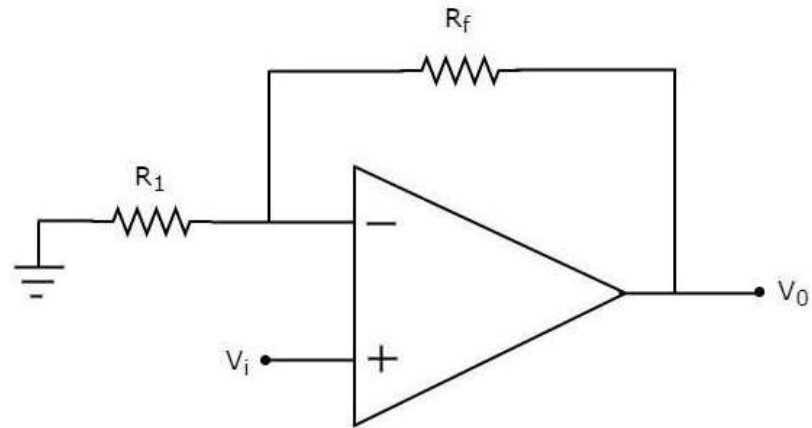

Figure 3. 18 Non-inverting feedback amplifier.

$$A_v = 1 + \frac{R_f}{R_1} \quad (3.5)$$

Feedback resistor pots can be used to adjust the gain of the non-inverting op-amp. Envelope detectors have loss gain about 5-6 dB. Input power of the satellite finder depends on the sensitivity.

Total gain of the satellite finder: -5 dB (Envelope detector loss) + 20log A_v

CHAPTER 4

RESULTS AND DISCUSSION

In this chapter, we will mention results of measurements acquired from the experimental setup and analyze them. Measurements are obtained from the oscilloscope. Minimum and maximum sensitivity of the analog satellite finder are -40 dBm and -10 dBm, respectively. Relation is between input power and output voltage of the satellite finder with tuned frequency at the maximum voltage gain, given below Figure 4.1. Output voltage values is obtained by sweeping the gain of the op-amp from the oscilloscope.

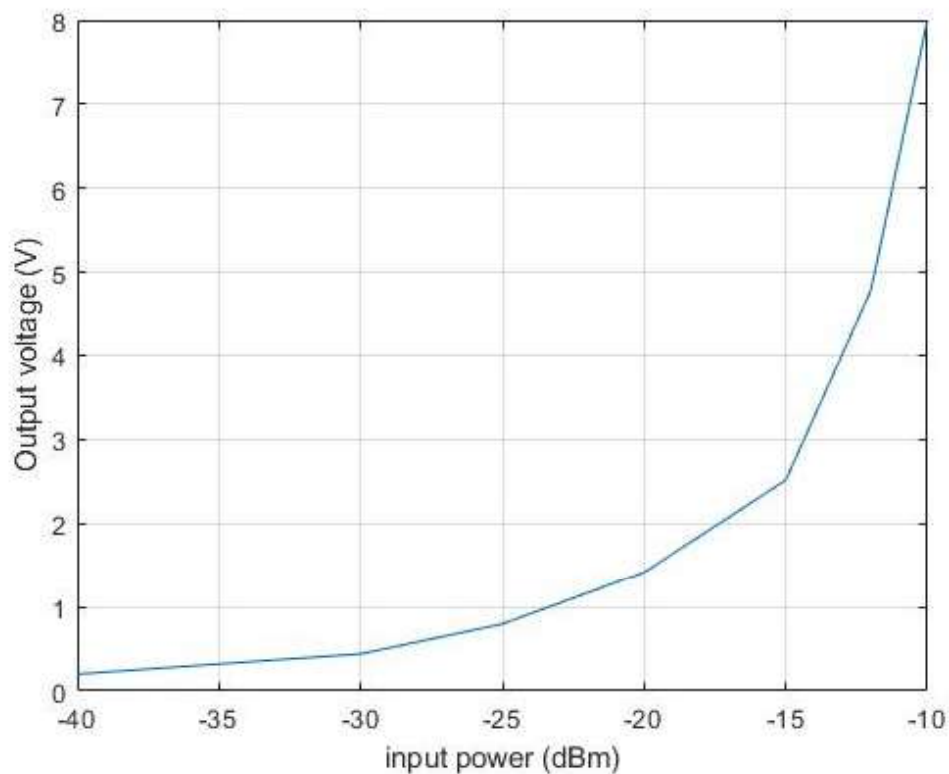

Figure 4. 1 Input power-output voltage relation.

Op-amp gain bandwidth product (GBP) is significant for the designing op-amp circuit. For the closed loop gain of the op-amp, the product of the gain against to frequency is constant for feedback amplifiers as given equation 4.1.

$$\text{GBP} = \text{Bandwidth} \times \text{frequency} = A_v \times f \quad (4.1)$$

Reducing the gain by 5 times would rise the bandwidth by the same factor. -3 dB bandwidth identifies the range of frequencies for which the power of the wave above the half power in the frequency domain. The half of the power is equal to 0.707V times of the peak-to-peak amplitude or -3 dB below of the power. In the input range of frequencies below the -3 dB system bandwidth is greatly attenuated while increasing the bandwidth. Square of the scaling factor of 0.707 for the amplitude of the voltage level equal to a power scaling factor $10\log(0.707)^2 = 0.5$. Square of the amplitude of the current or voltage corresponds to power scale factor. Frequency range between lower and higher cut off frequency corresponds to -3 dB bandwidth of the system. UGBW of this system would be about 15 kHz and bandwidth of the satellite finder at the maximum gain about 500Hz as seen in the Figure 4.5.

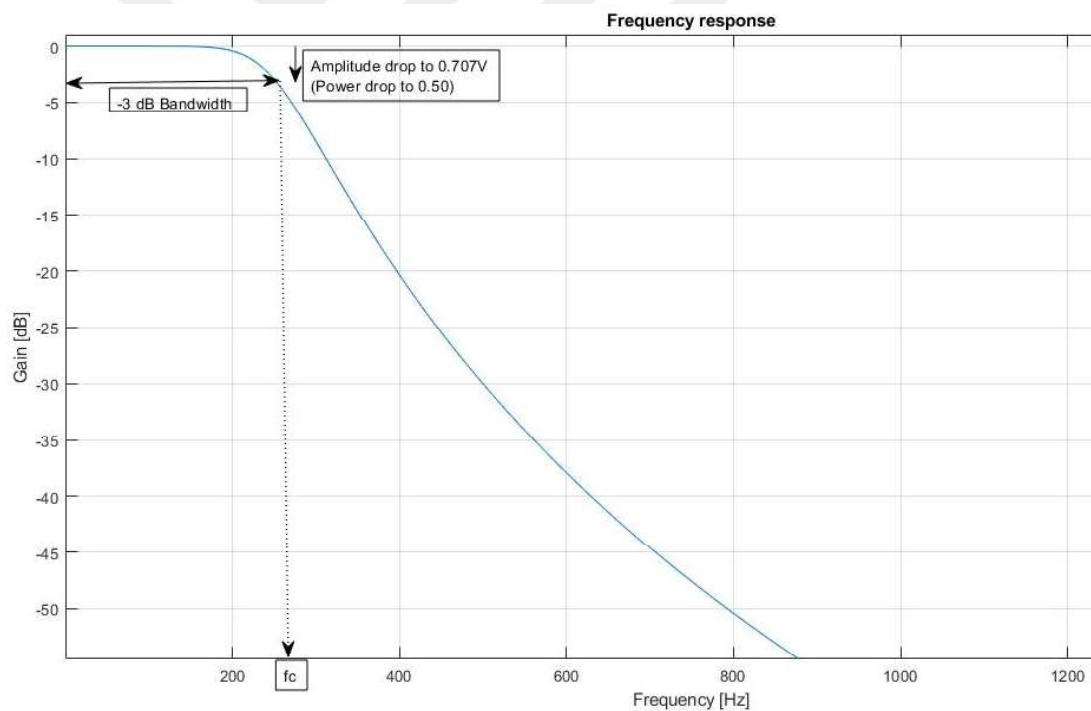

Figure 4. 2 Op-amp gain and frequency response.

Bandwidth is inversely related to rising edge of the square wave. Rise time is the measurement of the transition time from %10 to %90 level of the peak-to-peak voltage. Rise time (τ_r) is related to -3 dB bandwidth closely. Rise time decrease with increasing bandwidth.

$$\tau_r = \frac{0.35}{f_{3dB}} \quad (4.2)$$

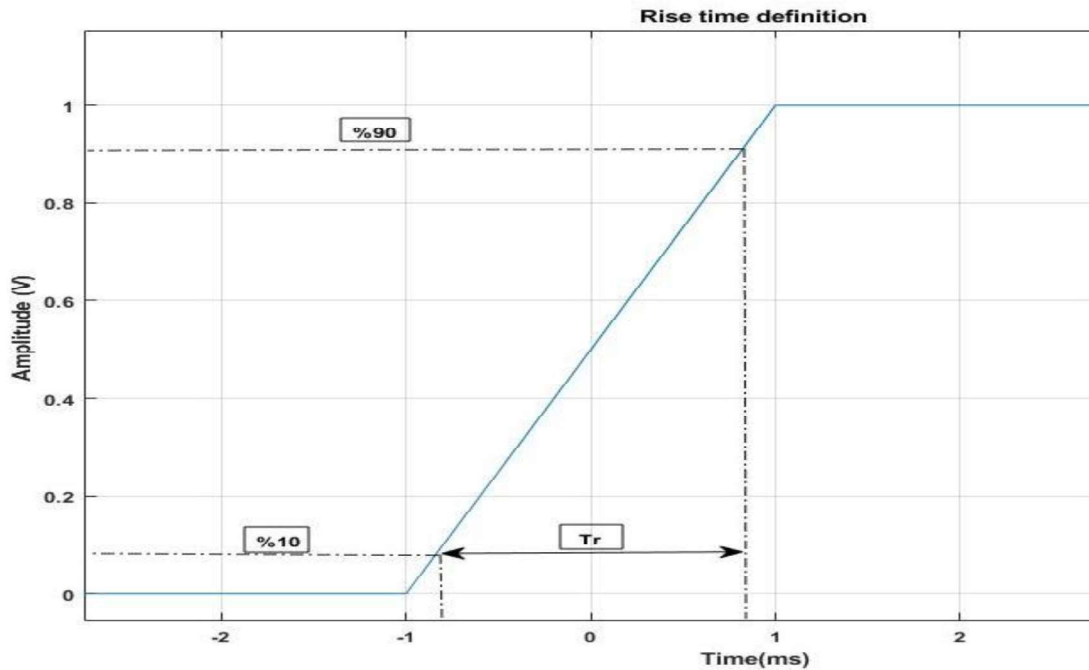

Figure 4. 3 Rise time.

Bandwidth of the ideal rectangular pulse is infinite so rise time and fall time are important for determination of the bandwidth of the pulse signal. In the receiver, pulse width with rise and fall time is required for the narrower bandwidth than ideal rectangular pulse width [36]. The spectrum of a trapezoidal pulse signal is given equation 4.3. Trapezoidal pulse is the convolution of the rectangular pulse with pulse width T and rise time T_r with rectangular pulse.

$$Envelope = AT \left[\frac{\sin(\pi T f)}{\pi T f} \right] \left[\frac{\sin(\pi T_r f)}{\pi T_r f} \right] \quad (4.3)$$

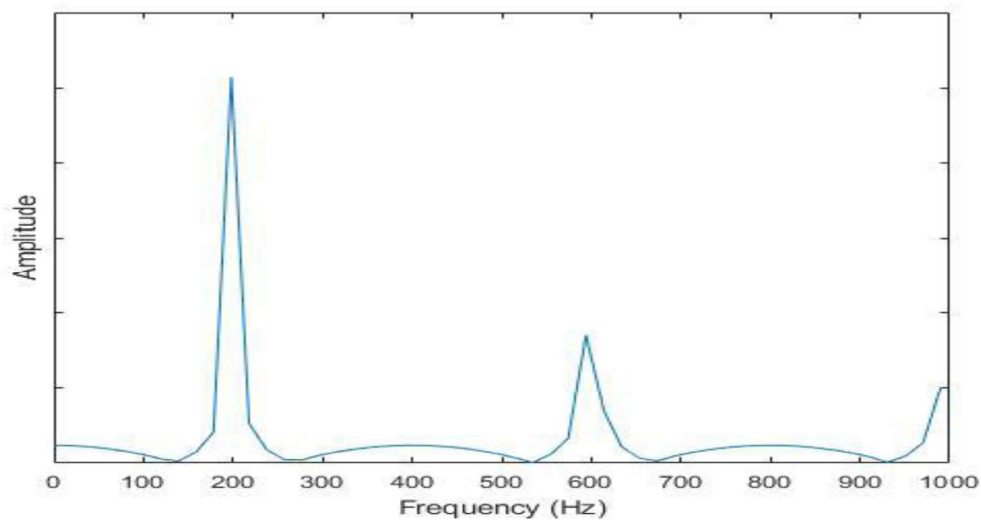
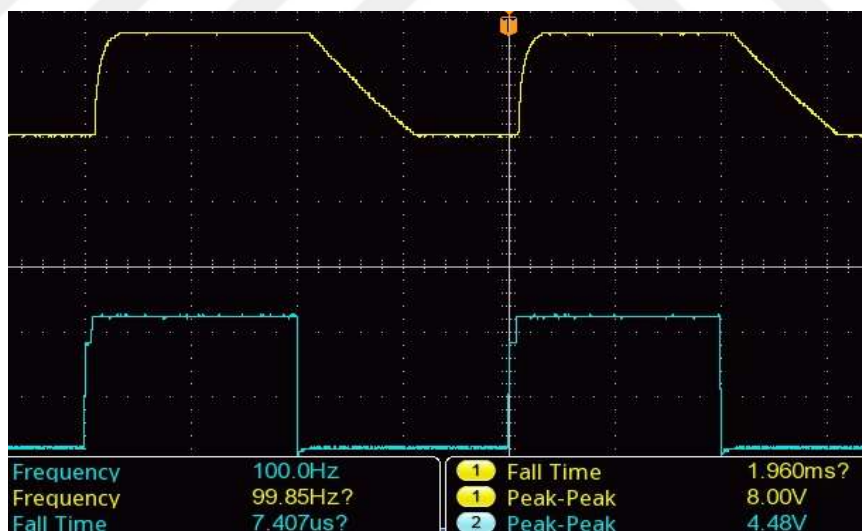
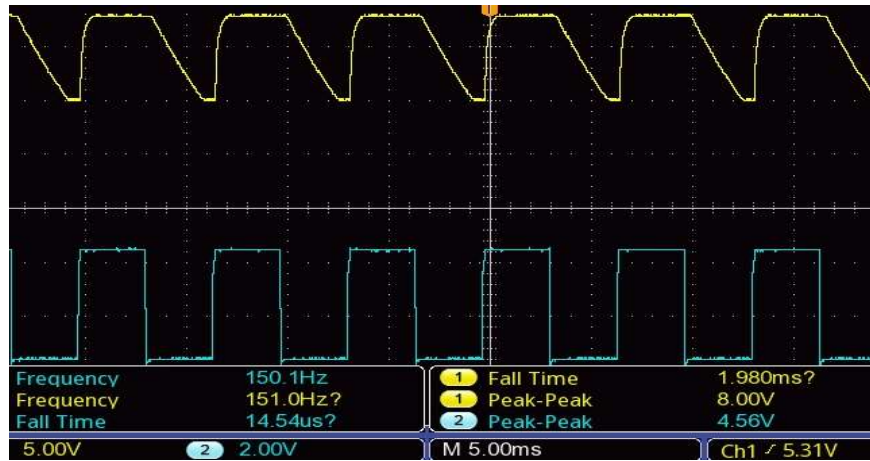

Figure 4.4 Spectrum of the rectangular pulse.

The repetitive train is the convolution between a set of impulses and a single rectangular pulse, so the spectrum is product between the spectrum of the impulses and single pulse (sinc function). Spectrum of the 100Hz rectangular pulse train with the %50 duty ratio is given Figure 4.4.



(a)



(b)

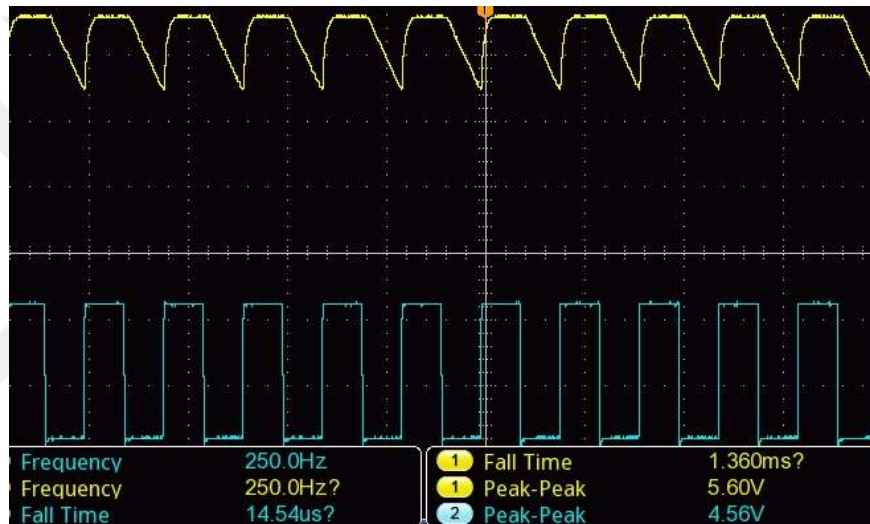

(c)

Figure 4. 5 Echo signals.

At the different frequencies with maximum op-amp gain and %50 duty cycle, echo signals are analyzed at the Figure 4.5. Echo signals are yellow and modulating transmitting pulse are the blue signals in the Figure 4.5. When the PRF increase, bandwidth of the transmitted signal increase due to narrower pulse width with decrease rise time. As the pulse repetition frequency increased, it was observed that the received echo signals were intertwined. Thus, target range ambiguity will be increased with increasing PRF. On the other hand, while the PRF is increasing, the amplitude of the received signal will decreasing, in the other means, received power reduce because the receiver's bandwidth cannot match the transmitter's bandwidth. If the received signal bandwidth exceeds the receiver bandwidth, SNR decrease. In the Figure 4.5, -3 dB bandwidth of the system is determined as a 500Hz at the maximum closed loop gain. Above the -3 dB bandwidth frequency of the feedback op-amp, detection of the receiver rapidly decreases with increasing PRF. Also, If the gain of the op-amp reduces, bandwidth of the satellite finder increases due to the unity gain product. It will decrease the sensitivity of the receiver but will increase the bandwidth of the receiver. Also, if the receiver exceeds the bandwidth rule, receiver degrades system performance due to greater level of noise because the noise will be dispersed to all frequencies in the receiver. It results that greater noise increase the required minimum detectable signal and cause to decrease maximum target range and range accuracy.

In addition to this, range resolution depends on bandwidth. If the pulse width decreased, range resolution will be improved due to wider bandwidth so duty ratio of the transmitted signal will effect the range resolution. In this experimental study, it was observed that if PRF is constant with narrower duty cycle, amplitude of the received signal increase on the oscilloscope since difference power increase between transmitted P_{on} and P_{off} , this situation is called contrast ratio.

Receiver requires minimum -105 dBm signal for the detection so we assumed that minimum detectable signal required -105 dBm in this experimental study. Maximum detection target range is calculated from the equation 2.5 and parameters is given below

Max $P_t = 18$ dBm (63 mW), $G_t = 10$ dB, $G_r = 5$ dB, $\sigma = 1\text{m}^2$, $S_{min} = -105$ dBm, $F = 10$ dB

With this experimental study, the target range is calculated to detect a human movement as 168 m at the maximum range. SNR value decreases as the target moves away from the radar as seen in the Figure 4.6. Detection target range decrease due to lower received power. SNR values calculated according to the varying target distance are plotted in matlab as given 4.6.

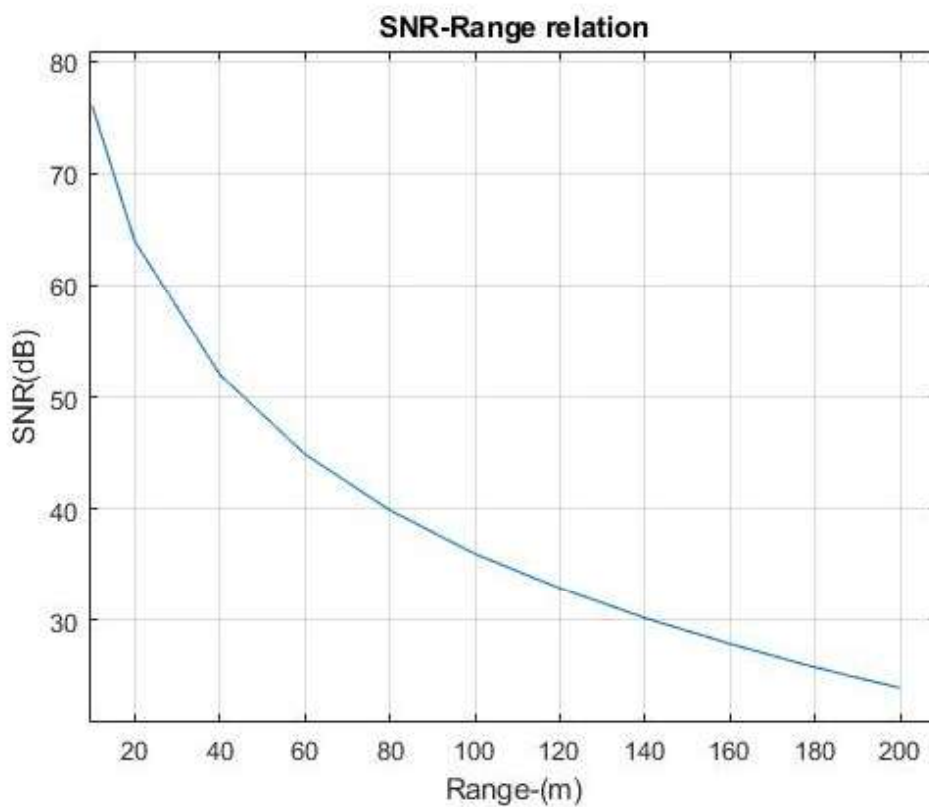

Figure 4. 6 SNR-Target range relation.

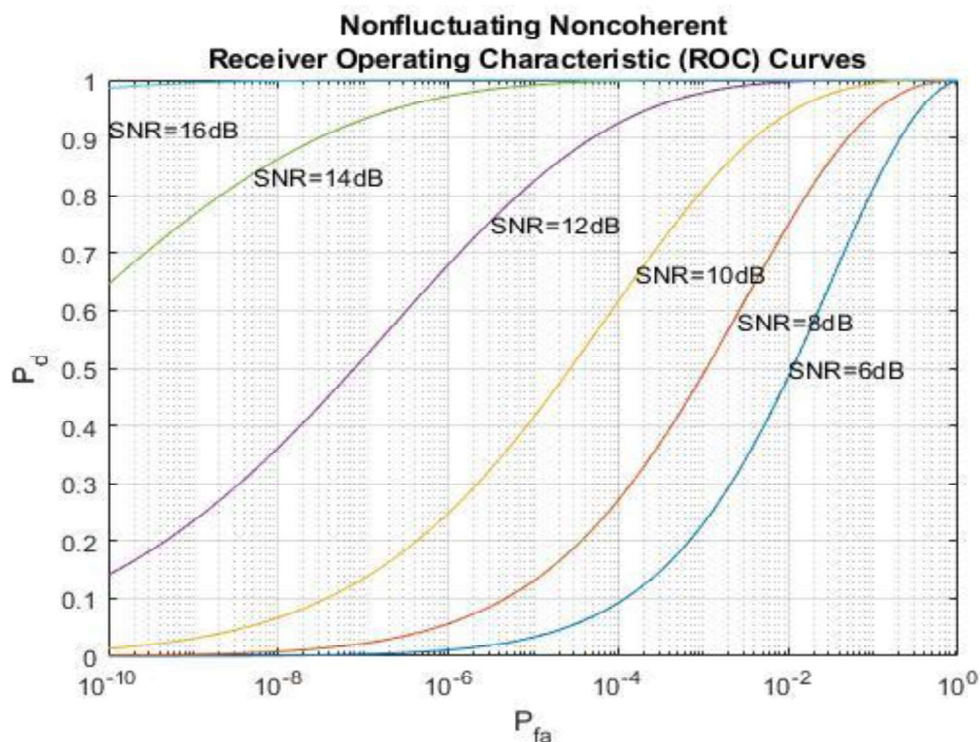

Figure 4.7 Receiver operating characteristic curve.

Receiver operating curve represents the performance of the detector. As seen in the Figure 4.7, we can see that it is obtained with a higher detection probability with the increase of SNR. If you are interested in analyzing the effect of varying the false-alarm probability on the probability of detection for a constant SNR, you can use receiver operating curve graph. If transmitted number of pulses are increased, required SNR decrease at the same propability of detection and probability of false alarm. But number of pulse will be limited, because of movement of the target.

In this thesis, SNR is obtained about 36 dB at the 500Hz bandwidth with 100 m range as shown Figure 4.6. By adjusting the gain of the power detector, minimum and maximum power signal can be detected from the LNB so we can get better information about the target and range. If the SNR decreases, the accuracy resolution decreases as the noise will be distributed over the signal because the receiver will reference the edge of the signal in the the threshold voltage, generally over the 0.707 maximum voltage, but since there will be noise on the signal, receiver takes the sum of the noise and echo signal voltage and there will be difference in the real measurement and without noissless.

CHAPTER 5

CONCLUSIONS AND RECOMMENDATIONS

Purpose of this experimental study is to investigate and design a low-cost perimeter security radar system at the X-Band. This radar system is based on a pulse radar system. Experimental setup system is designed for low cost about 20\$ and designed at a low cost compared to conventional radars. The basic advantage of this pulse radar is the practical setup and another advantage is that components of this radar system, HB100, LNB, analog satellite finder, is easily accessible in daily life. Components can be accessible at a low cost and setup the system for the practically. This perimeter surveillance radar requires low power and detect a target a up to 168m range for a 1 m² radar cross section. Components are explained in detail and setup of the radar system is mentioned at the chapter 3. Measurements of the experimental study is obtained and discussed in the chapter 4.

In the experimental study, HB100 is used as a signal generator about 10.525 Ghz and modulated with OOK technique from the function generator. PRF, PRI and pulse width are defining characteristic of radar system. We changed the PRF and pulse width of the transmitted signal and observed the detection capability of the receiver on the oscilloscope. LNB and analog satellite finder are connected together to form receiver system, used as a downconverter and power detector, respectively. Bandwidth of the receiver limited the detection of the target. As mentioned before, by adjusting the gain of the receiver, we can determine its sensitivity. Increasing sensitivity brings the greater determination of range, range accuracy, probability of detection so SNR is main significant factor for detection of probability and range accuracy. It is possible to reach more data about the target which is to be detected with more received power but increasing PRF, higher bandwidth will limit the sensitivity of the receiver due to unity gain bandwidth of non-inverter feedback op-amp. Envelope detector demodulator in the power detector provides the advantage of a maximum sensitivity of the radar receiver but drawback of the envelope detector does not provide Doppler

frequency analysis so does not detect phase detection so this system non-coherent system.

This thesis is a study of detection of objects with low-cost components on the low power and high frequency pulse radar. The radar system performance seems quite satisfying, but clutters affect the performance of test so measurements can be obtained in an open field. On the other hand, future work concerns deeper analysis of particular mechanisms, new proposals to try different methods, or simply curiosity. Lens can be used to improve the performance of the receiver in the future works. Lens can be used to improve the performance of the receiver in the future works and signal processing can be achieved with this setup.



REFERENCES

- [1] Butler, W., Poitevin P., Bjomholt, J., "Benefits of Wide Area Intrusion Detection Systems using FMCW Radar", 2007 41st Annual IEEE International Carnahan Conference on Security Technology", Ottawa, Ont., pp. 176-182, 2007.
- [2] Caruso, M., Meta, A., Corucci, L., Lombardo, P., "An X-band FMCW radar for airports' perimeter surveillance", 2013 14th International Radar Symposium (IRS), Dresden, pp. 853-858, 2013.
- [3] Jędrzejewski, K., Brawata, S., "A concept of smart low-cost FMCW-based perimeter radar system for border protection," 2019 Signal Processing Symposium (SPSymo), Krakow, Poland, pp. 156-160, 2019
- [4] Skolnik, M. I., "Radar Handbook", McGraw-Hill Educaion, New York, 2008.
- [5] Ju, Y., Jin, Y., Lee, J., "Design and implementation of a 24 GHz FMCW radar system for automotive applications", 2014 International Radar Conference, Lille, pp. 1-4, 2014.
- [6] Sarkar, T. K., Salazar Palma, M., "A history of the evolution of RADAR", 2014 44th European Microwave Conference, Rome, pp. 734-737, 2014.
- [7] History of Radar systems. (n.d) retrieved from <http://www.ob-ultrasound.net/radar.html>, 10 September 2020.
- [8] Wood, J., "A radar history of world war II: technical and military imperatives [Book reviews]," in *IEE Review*, vol. 47, no. 4, pp. 29-29, July 2001.
- [9] Shipton, H. W., "Radar History: The Need for Objectivity," *IEEE Transactions on Aerospace and Electronic Systems*, vol. AES-16, no. 2, pp. 244-244, March 1980.
- [10] Kuschel, H., O'Hagan, D., "Passive radar from history to future," 11-th international radar symposium, Vilnius, pp. 1-4, 2010.
- [11] Colton, R. B., "Radar in the United States Army History and Early Development at the Signal Corps Laboratories, Fort Monmouth, N.J.," in *Proceedings of the IRE*, vol. 33, no. 11, pp. 740-753, Nov. 1945.

- [12] İnanç, A., Şahin A. B., "Low-Cost Perimeter Intrusion Radar System Development," *2020 7th International Conference on Electrical and Electronics Engineering (ICEEE)*, Antalya, Turkey, pp. 206-210, 2020.
- [13] Williams, J. D., "Advanced technologies for perimeter intrusion detection sensors," *European Convention on Security and Detection, 1995.*, Brighton, UK, pp. 133-137, 1995.
- [14] Nobis, F., Geisslinger, M., Weber, M., Betz, J., and Lienkamp, M., "A Deep Learning-based Radar and Camera Sensor Fusion Architecture for Object Detection", *2019 Sensor Data Fusion: Trends Solutions Applications (SDF)*, pp. 1-7, 2019.
- [15] Ferdman, Y., Yekutieli D., and Sochen, N., "A method for radar detection and range-Doppler estimation", *2017 IEEE International Conference on Microwaves, Antennas, Communications and Electronic Systems (COMCAS)*, Tel-Aviv, pp. 1-6, 2017.
- [16] Akşimşek, H. S., "A Wideband low-frequency pulse radar for hidden objects detection", Thesis (MSc), Istanbul Technical University, 2010.
- [17] Boutkhil, M., Driouach A., Khamlichi, A., "Detecting and localizing moving targets using multistatic radar system", *Procedia Manufacturing*, vol 22, pp. 455-462, 2018.
- [18] Bezousek, P., & Schejbal, V., *Bistatic and Multistatic Radar Systems. Radioengineering*, vol. 17, no. 3, September 2008.
- [19] Victor C. Chen, & Ling H., "Time-Frequency Transforms for Radar Imaging and Signal Analysis", Artech House, London, 2002.
- [20] Wiesbeck, W., "Radar System Engineering", 16 th Edition, 2010.
- [21] Rezende, M. C., Alexandre, M, Miacci, S., Lu, E., "Radar Cross Section Measurements (8-12 GHz) of Magnetic and Dielectric Microwave Absorbing Thin Sheets", *Material Science*, (2002).
- [22] Nicolaescu, L., Oroian, T., "Radar cross section", *5th International Conference on Telecommunications in Modern Satellite, Cable and Broadcasting Service. TELSIKS 2001. Proceedings of Papers (Cat. No.01EX517)*, Nis, Yugoslavia, pp. 65-68 vol.1, 2001.

- [23] Knott, E. F., & Shaeffer, J. F., Tuley, & M. T., "Radar Cross Section", SciTech Publishing, 2004.
- [24] Raisanen, A. V., & Lehto A., "Radio Engineering for Wireless Communication and Sensor Applications", Artech House, Boston, Massachusetts, 2003.
- [25] Bagad V. S., "Radar System", Nirali Book House, First edition-2008.
- [26] Tait P., "Introduction to Radar Target Recognition", The Institution of Engineering and Technology, London, UK, 2005.
- [27] Kirkman-Bey M., P., Cintron-Tirado, R. Sebsebie, Dogan N. and Z. Xie, "Design and simulation of Ku-Band Low-Noise Block Down-Converter in 0.18 micrometer CMOS technology", *IEEE SOUTHEASTCON 2014*, Lexington, KY, pp. 1-6, 2014.
- [28] Jyrki T., J. Penttinen," The Telecommunications Handbook: Engineering Guidelines for Fixed, Mobile and Satellite Systems", John Wiley & Sons, 2015.
- [29] John E., "VSATs: Very Small Aperture Terminals", IET, 1992.
- [30] Wikipedia contributors, "[https://en.wikipedia.org/w/index.php?title=Low noise_block_downconverter&oldid=969792292](https://en.wikipedia.org/w/index.php?title=Low_noise_block_downconverter&oldid=969792292) ", 14 December 2020.
- [31] Mark E. Long," The Digital Satellite TV Handbook", Newnes, 1999.
- [32] Lawal, L. S., Ahmed-Rufai, T., Chatwin, Chris., "Communication satellite alternative to digital terrestrial television", "2nd IEEE international conference on emerging and sustainable Technologies for power and ICT in a developing society", Owerri, Nigeria, 2013.
- [33] Reyes, L., Silveira, F., "Analysis and design of a MOS RF envelope detector in all inversion regions", 2015 28th Symposium on Integrated Circuits and Systems Design (SBCCI), Salvador, pp. 1-5, 2015.
- [34] Alegre, J. P., Celma, S., Sanz, M. T., Aldea, C., "Design of a High-performance Envelope Detector", 2006 49th IEEE International Midwest Symposium on Circuits and Systems, San Juan, pp. 685-689, 2006
- [35] Y. Su, Q. Xia, L. Geng and X. Liu, "A Highly Linear Low Power Envelope Detector", 2019 IEEE International Conference on Electron Devices and Solid-State Circuits (EDSSC), Xi'an, China, pp, 2019

- [36] Kang, M. S., Kim B. S., Kim, H. J., "The Effect of Pulse Signal Waveform on Bandwidth in Pulse Radar System", 2018 International Conference on Information and Communication Technology Convergence (ICTC), Jeju, pp. 1-2, 1064-1066, 2018.

