

THE NATURE OF INTERPLAY AMONG COMPONENTS OF PEDAGOGICAL  
CONTENT KNOWLEDGE IN REACTION RATE AND CHEMICAL  
EQUILIBRIUM TOPICS OF NOVICE AND EXPERIENCED CHEMISTRY  
TEACHERS

A THESIS SUBMITTED TO  
THE GRADUATE SCHOOL OF NATURAL AND APPLIED SCIENCES  
OF  
MIDDLE EAST TECHNICAL UNIVERSITY



BY  
FATMA NUR AKIN

IN PARTIAL FULFILLMENT OF THE REQUIREMENTS  
FOR  
THE DEGREE OF DOCTOR OF PHILOSOPHY  
IN  
MATHEMATICS AND SCIENCE EDUCATION

JANUARY 2017



Approval of the thesis:

**THE NATURE OF INTERPLAY AMONG COMPONENTS OF  
PEDAGOGICAL CONTENT KNOWLEDGE IN REACTION RATE AND  
CHEMICAL EQUILIBRIUM TOPICS OF NOVICE AND EXPERIENCED  
CHEMISTRY TEACHERS**

submitted by **FATMA NUR AKIN** in partial fulfillment of the requirements for the degree of **Doctor of Philosophy in Mathematics and Science Education Department, Middle East Technical University** by,

Prof. Dr. Gülbin Dural Ünver  
Dean, Graduate School of **Natural and Applied Sciences**

Prof. Dr. Ömer Geban  
Head of Department, **Mathematics and Science Education**

Prof. Dr. Esen Uzuntiryaki Kondakçı  
Supervisor, **Mathematics and Science Education Dept., METU**

**Examining Committee Members:**

Prof. Dr. Ayhan Yılmaz  
Mathematics and Science Education Dept., Hacettepe University

Prof. Dr. Esen Uzuntiryaki Kondakçı  
Mathematics and Science Education Dept., METU

Prof. Dr. Yezdan Boz  
Mathematics and Science Education Dept., METU

Prof. Dr. Jale Çakıroğlu  
Mathematics and Science Education Dept., METU

Assoc. Prof. Dr. Hüseyin Akkuş  
Mathematics and Science Education Dept., Gazi University

**Date:** 30.01.2017



**I hereby declare that all information in this document has been obtained and presented in accordance with academic rules and ethical conduct. I also declare that, as required by these rules and conduct, I have fully cited and referenced all materials and results that are not original to this work.**

Name, Last name: Fatma Nur Akin

Signature:

## ABSTRACT

### **THE NATURE OF INTERPLAY AMONG COMPONENTS OF PEDAGOGICAL CONTENT KNOWLEDGE IN REACTION RATE AND CHEMICAL EQUILIBRIUM TOPICS OF NOVICE AND EXPERIENCED CHEMISTRY TEACHERS**

Akın, Fatma Nur

Ph.D., Department of Mathematics and Science Education

Supervisor: Prof. Dr. Esen Uzuntiryaki Kondakçı

January 2017, 223 pages

In this qualitative multiple-case design study, I examined the interactions among pedagogical content knowledge (PCK) components of novice and experienced chemistry teachers in teaching reaction rate and chemical equilibrium topics. For this aim, three chemistry teachers who had different levels of teaching experience in chemistry teaching were selected through a process of purposeful sampling. Data were collected through card-sorting task, Content Representation (CoRe) tool, semi-structured interviews, observation of instructions, and field notes. Data were analyzed through three approaches: in-depth analysis of explicit PCK, enumerative approach, and constant comparative methods. Results revealed nine salient features of the interplay of the PCK components: a) The novice teacher's orientations towards science, in contrast to the experienced teachers, were much broad and non-specific, which impeded the connections among the components, b) The integration of the PCK components was idiosyncratic and topic specific, c) The novice teacher's PCK maps were fragmented while the experienced teachers' PCK

maps were integrated, d) Knowledge of learner, knowledge of curriculum and knowledge of instructional strategies were central in the interplays of all teacher maps, e) The novice and experienced teachers displayed different levels of complexity in their interactions among PCK components, f) The experienced teachers had much more two-way interactions among PCK components than the novice teacher, g) The experienced teachers were more successful than the novice teacher in translating their knowledge into practice in terms of the integration among PCK components, h) Teacher self-efficacy appeared to play a role in their use of PCK components and constructing interactions among them, and i) All teachers taught the same topics with similar lesson plans and same instructional materials; however, they differed in terms of how effectively they connect the PCK components. Implications for teacher education and suggestions for science education research are presented.

Keywords: Pedagogical Content Knowledge, Interplay among PCK Components, Novice Teachers, Experienced Teachers, Multiple Case Study

## ÖZ

# **DENEYİMLİ VE DENEYİMSİZ KİMYA ÖĞRETMENLERİNİN REAKSİYON HIZI VE KİMYASAL DENGE KONULARINDA PEDAGOJİK ALAN BİLGİSİ BİLEŞENLERİ ARASINDAKİ ETKİLEŞİMİN DOĞASI**

Akın, Fatma Nur

Doktora, Matematik ve Fen Alanları Eğitimi Bölümü

Tez Yöneticisi: Prof. Dr. Esen Uzuntiryaki Kondakçı

January 2017, 223 Sayfa

Bu çoklu durum çalışmasının amacı, farklı öğretmenlik deneyimine sahip kimya öğretmenlerinin reaksiyon hızı ve kimyasal denge ünitesinde sahip oldukları pedagojik alan bilgisi (PAB) bileşenleri arasındaki etkileşimi incelemektir. Bu amaçla, farklı öğretmenlik deneyimine sahip üç kimya öğretmeni amaçlı örneklem yöntemi ile seçilmiştir. Veriler, kart-gruplama aktivitesi, içerik gösterimi, yarı-yapılandırılmış görüşmeler, sınıf gözlemleri ve gözlem notları ile toplanmıştır. Verilerin analizinde derinlemesine PAB ve sürekli karşılaştırmalı veri analiz yöntemleri kullanılmıştır. Çalışmanın sonuçları, PAB bileşenleri arasındaki etkileşim için dokuz özellik ortaya koymuştur: a) Deneyimli öğretmenin aksine, deneyimsiz öğretmenin fen öğretimine bakış açısı geneldir, ve bu PAB bileşenleri arasındaki etkileşimi engellemektedir, b) PAB bileşenleri arasındaki etkileşim kendine ve konuya özgüdür, c) Deneyimsiz öğretmenlerin PAB haritaları parçalı bir yapıya sahipken, deneyimli öğretmenlerin PAB haritaları bütüncül bir yapıya sahiptir, d) Bütün haritalardaki etkileşimlerde, öğrenci, müfredat ve öğretimsel bilgiler merkezidir, e) Deneyimli ve deneyimsiz öğretmenler PAB bileşenleri arasında farklı

düzeyde karmaşık etkileşimler gösterirler, f) Deneyimli öğretmenler, deneyimsiz öğretmenlere göre, daha fazla çift yönlü etkileşimlere sahiptirler, g) Deneyimli öğretmenler, deneyimsiz öğretmenlere göre, PAB bileşenleri arasındaki etkileşimi bilgi düzeyinden uygulama düzeyine dönüştürmede daha başarılıdır, h) Öğretmen özyeterliğinin, PAB bileşenleri kullanımında ve bileşenler arasında etkileşim kurmada rol oynadığı görülmüştür, ve i) Tüm öğretmenler aynı konuyu benzer ders planlarıyla ve aynı öğretim materyalleri ile öğretmenlerine rağmen, PAB bileşenleri arasında nasıl etkili etkileşimler kurdukları farklılık göstermiştir. Bu sonuçların, öğretmen eğitime katkıları ve fen eğitimi araştırmaları için önerileri tartışılacaktır.

Anahtar Kelimeler: Pedagojik alan bilgisi, PAB bileşenleri arasındaki etkileşim, deneyimli öğretmenler, deneyimsiz öğretmenler, çoklu durum çalışması



To My Lovely Daughter Ela Erva, My Husband and My Dear Whole Family

## ACKNOWLEDGMENTS

I would like to thank my advisor, Prof. Dr. Esen UZUNTIRYAKI KONDAKCI, for her valuable support and guidance for conducting this research. You always supported and encouraged me to study throughout my PhD. When I needed feedback, you always agreed to come together and provided the support that I needed. You are always polite and helpful to me. I learned a lot from your ideas, feedbacks and suggestions. This study could not have been richer and valuable without your feedbacks and thoughts. You are always a great role model for me as an academic. Thank you so much for your support and encouragement.

I also would like to thank my dissertation committee members, Prof. Dr. Jale ÇAKIROĞLU and Prof. Dr. Yezdan BOZ for being so insightful and helpful. I greatly appreciate all of the contributions and guidance in helping me complete this study.

My sincere thanks also goes to our PCK research group members. I cannot thank enough to Assist. Prof. Dr. Betül DEMİRDÖĞEN. I really appreciated the time and effort that you spent for my research. You always supported and encouraged me to study throughout my PhD. Additionally, Assoc. Prof. Dr. Sevgi AYDIN GÜNBATAR, and Assist. Prof. Dr. Ayşegül TARKIN also deserves special thanks. I really enjoyed and learned a lot from you during our meetings. Your ideas, questions and feedbacks were very valuable for improving myself as an academic. Thank you all for your help and support during instrument development, data collection and data analysis.

I also would like to express thanks to my close friend, Kübra ERYURT for your friendship and support. I am really thankful to you for being both a friend and sister to me. In addition, my special friends, Dr. Eray ŞENTÜRK, Semra TAHANCALIO, Mehmet Ali TAHANCALIO, and all friends in SSME department also deserve special thanks. You have been always supportive, encouraging, and close to me during my PhD journey. Thank you all for being a part of my life and will be.

Last but not the least I am also very thankful to my family. My lovely and cheerful daughter, Ela Erva AKIN, words are not enough to describe my feelings and how much I appreciate your love and cheer. My husband, Mustafa Umut AKIN who is with me whenever I need him and always supports me, also deserves special thanks. Thanks both of you so much for your endless love and patience. This study would not be ended without your encouragement, support and love. Also, I am really lucky for being a member of KURT and AKIN families. Thank you very much for your continuous support and encouragement. My mother and father are devoted themselves to raise me as a hardworking and honest person. My sisters, brothers, cousins and nephews deserve very special thanks for their encouragement and support. Specially, I want to thank to one of my cousin, Burak KURT, for his help and support.

Finally, I would like to thank to TÜBİTAK for financial support throughout the PhD with BİDEP- 2211 scholarship provided to PhD students in Turkey.

## TABLE OF CONTENTS

ABSTRACT .....	v
ÖZ.....	vii
ACKNOWLEDGMENTS.....	x
TABLE OF CONTENTS .....	xii
LIST OF TABLES .....	xvi
LIST OF FIGURES.....	xvii
LIST OF ABBREVIATIONS .....	xix
CHAPTERS .....	1
1. INTRODUCTION.....	1
1.1. Purpose of the Study .....	5
1.2. Research Questions .....	5
1.3. The Intended Audience of the Research .....	5
1.4. Definitions of Important Terms .....	5
1.5. Significance of the Study .....	9
2. REVIEW OF LITERATURE .....	13
2.1. Conceptualization of Pedagogical Content Knowledge .....	13
2.2. The Nature and Characteristics of PCK.....	36
2.3. Research on Interplay among PCK components .....	43
2.4. Research on how teaching experience is related to PCK development ...	52
2.5. Summary of the Literature Review .....	62
2.6. PCK Framework of the Present Study .....	64
3. METHODOLOGY.....	67
3.1. Research Questions .....	67
3.2. Design of the Study.....	67
3.3. Participants.....	72
3.4. The Subject Matter and Topic Selection.....	75
3.5. Context of the Study .....	76

3.6. Data Collection Sources .....	77
3.6.1. Card-sorting Task .....	79
3.6.2. Interviews.....	81
3.6.3. Pre-interviews in the Form of Content Representations (CoRe)....	82
3.6.4. Observation of Instructions.....	83
3.6.5. Post-interviews about Instructions.....	85
3.7. Data Analysis .....	87
3.7.1. Data Analysis for Science Teaching Orientations .....	91
3.7.2. Data Analysis for Interactions among PCK Components .....	92
3.7.2.1. In-depth analysis of explicit PCK.....	93
3.7.2.2. Enumerative approach.....	93
3.7.2.3. Constant-comparative method.....	96
3.8. Reliability and Validity Issues of the Study .....	96
3.8.1. Dependability.....	97
3.8.2. Credibility .....	98
3.8.2.1. Triangulation .....	98
3.8.2.2. Member checking .....	99
3.8.2.3. Prolong engagement .....	100
3.8.2.4. Peer debriefing.....	100
3.8.3. Transferability.....	101
3.9. Key Words and Databases Searched .....	101
3.10. Researcher's Background and Role .....	102
3.11. Negotiating Entry .....	104
3.12. Ethical Considerations.....	104
3.13. Limitations of the Study .....	105
3.14. Time Schedule.....	106
3.15. Assumptions of the Study .....	106
4. RESULTS .....	107
4.1. The novice teacher's orientations towards science, in contrast to the experienced teachers, were much broad and non-specific, which impeded the connections among the components.....	109

4.2. The integration of the PCK components was idiosyncratic and topic specific.....	117
4.3. The novice teacher’s PCK maps were fragmented while the experienced teachers’ PCK maps were integrated.....	124
4.4. Knowledge of learner, knowledge of curriculum and knowledge of instructional strategies were central in the interplays of all teacher maps ...	129
4.5. The novice and experienced teachers displayed different levels of complexity in their interactions among PCK components.....	134
4.6. The experienced teachers had much more two-way interactions among PCK components than the novice teacher.....	137
4.7. The experienced teachers were more successful than the novice teacher in translating their knowledge into practice in terms of the integration among PCK components.....	152
4.8. Teacher self-efficacy appeared to play a role in their use of PCK components and constructing interactions among them.....	157
4.9. All teachers taught the same topics with similar lesson plans and same instructional materials; however, they differed in terms of how effectively they connect the PCK components.....	164
4.10. Summary of the Results.....	170
5. DISCUSSION, CONCLUSION AND IMPLICATIONS.....	175
5.1. Discussion.....	175
5.1.1. Discussion of the results regarding the assertion that the novice teacher’s orientations towards science, in contrast to the experienced teachers, were much broad and non-specific, which impeded the connections among the components.....	175
5.1.2. Discussion of the results regarding the assertion that the interplay of the components was idiosyncratic and topic-specific.....	178
5.1.3. Discussion of the results regarding the assertion that the novice teacher’s PCK maps were fragmented while the experienced teachers’ PCK maps were integrative.....	180
5.1.4. Discussion of the results regarding the assertion that the knowledge of learner, knowledge of curriculum and knowledge of instructional strategies were central in the interplays of all teacher maps.....	182
5.1.5. Discussion of the results regarding the assertion that the novice and experienced teachers displayed different levels of complexity in their interactions among PCK components.....	184

5.1.6. Discussion of the results regarding the assertion that the experienced teachers had much more two-way interactions among PCK components than the novice teacher .....	185
5.1.7. Discussion of the results regarding the assertion that the experienced teachers were more successful than the novice teacher in translating their knowledge into practice in terms of the integration among PCK components .....	187
5.1.8. Discussion of the results regarding the assertion that teacher self-efficacy appeared to play a role in their use of PCK components and constructing interactions among them .....	188
5.1.9. Discussion of the results regarding the assertion that all teachers taught the same topics with similar lesson plans and same instructional materials; however, they differed in terms of how effectively they connect the PCK components .....	190
5.2. Conclusion .....	191
5.3. Implications and Suggestions for Practice .....	192
5.4. Suggestions for Science Education Research .....	198
REFERENCES .....	201
APPENDICES .....	209
A. CARD-SORTING ACTIVITY (IN TURKISH) .....	209
B. CONTENT REPRESENTATION (CoRe) .....	211
C. SAMPLE INTERVIEW QUESTIONS .....	213
D. PCK CODING TABLE .....	215
E. INSTUTIONAL REVIEW BOARD PERMISSION .....	217
CURRICULUM VITAE .....	219

## LIST OF TABLES

### TABLES

Table 2.1 The goals of different orientations to teaching science .....	23
Table 3.1 Information about the participants .....	75
Table 3.2 A summary of all data sources .....	86
Table 3.3 Categories for analyzing data and their explanations .....	90
Table 3.4 Timeline for the research .....	106
Table 4.1 Nine assertions regarding the interaction among PCK components .....	109
Table 4.2 Teachers' science teaching orientations derived from card-sorting task before their instructions .....	110
Table 4.3 Teachers' science teaching orientations: central and peripheral goals from long-observation period and post-interviews about the instructions .....	111
Table 4.4 The frequency of total interactions among PCK components for reaction rate and chemical equilibrium .....	118
Table 4.5 The most and least frequent interactions in the participants' PCK Map for reaction rate and chemical equilibrium .....	121

## LIST OF FIGURES

### FIGURES

Figure 2.1 Model of teacher knowledge .....	17
Figure 2.2 Cochran et al's (1993) PCK model .....	18
Figure 2.3 Integrative model and transformative models of PCK .....	20
Figure 2.4 A model of the relationships among the domains of teacher knowledge .....	21
Figure 2.5 Components of PCK for science teaching .....	22
Figure 2.6 General Taxonomy of PCK .....	26
Figure 2.7 Bird's Eye View of Taxonomy of PCK Attributes .....	27
Figure 2.8 Model of a hypothetical science teacher's knowledge and beliefs .....	29
Figure 2.9 Pentagon model of PCK for science teaching .....	30
Figure 2.10 Hexagon model of PCK for science teaching .....	32
Figure 2.11 Model of teacher professional knowledge and skill including PCK and influences on classroom practice and student outcomes .....	33
Figure 2.12 A model illustrating differential influences of the development of PCK for two hypothetical teachers .....	38
Figure 2.13 PCK model for the novice teacher .....	42
Figure 2.14 PCK model for the experienced teacher .....	42
Figure 3.1 Arrangement of the classroom .....	77
Figure 3.2 The data collection stages .....	78
Figure 3.3 Example of the first step of the enumerative approach .....	94
Figure 3.4 Simge's PCK map for teaching of chemical equilibrium .....	95
Figure 4.1 PCK Maps .....	108
Figure 4.2 Quicklime (calcium oxide) .....	127
Figure 4.3 Potential energy vs reaction pathway graph .....	127
Figure 4.4 A Representation for the equilibrium reaction of sulfur dioxide .....	134
Figure 4.5 Map for directions of the interactions in Burak's teaching segments .....	138
Figure 4.6 Hypothetical reaction of $X(g) \leftrightarrow Y(g)$ .....	139
Figure 4.7 Map for directions of the interactions in Simge's teaching segments .....	143

Figure 4.8 Energy profiles for a catalyzed and uncatalyzed reaction .....	147
Figure 4.9 Map for directions of the interactions in Betül's teaching segments.....	148
Figure 4.10 Concentration vs. time graph drawn in the classroom .....	149
Figure 4.11 Number of particles vs. collision energy .....	150
Figure 4.12 The reaction in which A is converted to B ( $A \rightarrow B$ ) at sub-microscopic .....	161



## LIST OF ABBREVIATIONS

PCK:	Pedagogical Content Knowledge
MoNE:	Ministry of National Education
IRB:	Institutional Review Board
STS:	Science, Technology and Society
CoRe:	Content Representation
NOS:	Nature of Science
STO:	Science Teaching Orientations
KoL:	Knowledge of Learner
KoC:	Knowledge of Curriculum
KoIS:	Knowledge of Instructional Strategies
KoA:	Knowledge of Assessment



## CHAPTER 1

### INTRODUCTION

Chemistry courses are widely acknowledged to be highly demanding for learners. Since chemical concepts are abstract and chemical reasoning involves a macroscopic/microscopic relationship, students often have difficulties in explaining chemical phenomena (Erduran, Bravo, & Naaman, 2007). Research has shown that students unfortunately possess many alternative conceptions related to chemistry concepts not only because chemistry is a complex subject, but also because of the way the concepts are taught (Gabel, 1996). Therefore, teachers require improving a particular domain of knowledge that exceeds content knowledge in order to accommodate various interests, comprehension, abilities, and experiences of students (Park & Chen, 2012).

Teachers may have common questions in their mind while planning and enacting their teaching such as: Which difficulties do my students have while learning the science concept? What can I do for my students to help them comprehend that science concept? What are the materials that I will use to help them improve their understanding of that concept? How do I evaluate my students' understandings? (Magnusson, Krajcik & Borko, 1999) To find an answer for these kinds of questions, teachers require a special kind of teacher knowledge domain that distinguishes a teacher from a subject matter specialist (Magnusson et al., 1999). In this respect, Shulman (1987) introduced pedagogical content knowledge (PCK) as a central element in the knowledge base of teaching and teachers' particular practical knowledge required to help learners comprehend specific content. According to Shulman (1986), teacher education programs needs to compound content and pedagogy instead of looking teacher education from the aspect of content or pedagogy. Shulman argued that the comprehension of how subject matter was transformed into instruction is at the heart of teaching. Therefore, he defines PCK as a specific mixture of content and pedagogy for teaching a topic. From this point of

view, effective teachers should utilize both content and pedagogical knowledge, transform them into knowledge for teaching particular topics. Shulman (1986) describes PCK as “...the most useful forms of content representation, the most powerful analogies, illustrations, examples, explanations, and demonstrations— in a word, the ways of representing and formulating the subject that makes it comprehensible to others” (p. 9). PCK also comprises a comprehension of what makes the learning of particular topics easy or difficult. According to Shulman (1986), PCK concerns its relation to specific subjects. From this aspect, a science teacher would have a different subject-specific PCK than a mathematics teacher. Moreover, PCK is defined as topic-specific knowledge for teaching a specific subject. Additionally, according to his conceptualization, PCK consists of two key elements which are knowledge of representations of subject matter and understanding of specific learning difficulties.

Since the introduction of PCK, a large number of educational scholars have worked on the concept (e.g., Park & Oliver, 2008a; Hashweh, 2005; Grossman, 1990). Some of these scholars have tried to modify Shulman’s definition and identify different components. For instance, Grossman (1990) defines PCK as the result of a transformation of three main knowledge domains -subject matter knowledge, general pedagogical knowledge, and knowledge of context-. PCK is put in the center of the model and demonstrated it as influenced by and influencing the other three main knowledge domains (Grossman, 1990). PCK includes knowledge and beliefs about the purposes for teaching a subject at different grade levels; knowledge of students’ understanding, conceptions, and misconceptions of particular topics in a subject matter; curricular knowledge; and knowledge of instructional strategies and representations for teaching particular topics (Grossman, 1990). The sources of ideas that contribute to the improvement of PCK are identified; namely, apprenticeship of observation (both as a student and a preservice teacher), disciplinary background, professional coursework, and learning from experience (i.e., teaching experience). Many researchers ascribes teaching experience as the primary source of PCK development (Van Driel, De Jong, & Verloop, 2002; Van Driel, Verloop, & De Vos,

1998; Grossman, 1990; Magnusson et al., 1999; Van Driel, Beijaard, & Verloop, 2001), while others emphasize that teaching experience alone does not lead necessarily to robust PCK (Leite, Mendoza, & Borsese, 2005; Friedrichsen et al., 2009). For instance, Lee, Brown, Luft and Roehring (2007) support that PCK can be improved through teaching experience; therefore preservice and novice teachers may possess limited or minimal PCK. Similarly, De Jong and Van Driel (2004) argue that teachers require gaining experiences according to teaching specific topics in practice in order to develop PCK. On the other hand, Friedrichsen et al., (2009) support that there were few differences between teachers with teaching experience and those lacking teaching experience and both groups lacked topic-specific PCK. Therefore, teaching experience alone is not adequate for constructing knowledge for teaching (Friedrichsen et al., 2009).

In addition to this discussion, researchers have discussed the development of PCK as an integrative process among PCK components. Grossman (1990), the first scholar who took the interactions among PCK components into consideration, stated that "...these components are less distinct in practice than in theory" (p.9). Then, Magnusson et al. (1999) enhanced the concept of PCK further with some change (e.g., addition of one more component). They conceptualized PCK for science teaching as a mixture of five types of knowledge: orientations towards science teaching, knowledge and beliefs about science curriculum, knowledge and beliefs about students' understanding of specific science topics, knowledge and beliefs about assessment in science, and knowledge and beliefs about instructional strategies for teaching science. They emphasized two important ideas about PCK with their model. First, each component shows that there are various types of subject-specific pedagogical knowledge used in science teaching. Second, they depicted the components as parts of a single construct (PCK). Effective teachers should enhance all aspects of PCK while teaching a particular topic. Therefore, lack of coherence among the components can cause problems in improving and utilizing PCK. In other words, the relations among the components are very important. It is also important to note that teachers' developed knowledge of one component may not be adequate to

affect change in practice. Magnusson et al. (1999) underlined that these components may interact in highly complex ways; therefore, it is substantial to comprehend how they interact and how their interactions affect teaching. Nevertheless, in their PCK model, the five components are represented in a linear way and the only explicit interaction in this model is between science teaching orientation and each of the other four components. In contrast to Magnusson et al.'s linear model, Park and Oliver (2008a) presented the same five components in a pentagonal form to represent the integration of the components in to the PCK. They highlighted that “strong PCK has all components connected to each other strongly enough to enable the whole structure of PCK to function for scaffolding student learning” (p.926). Abell (2008) also emphasized that no matter how PCK components have been conceptualized; the key point is that PCK is more than the sum of its components.

In this respect, researchers have confessed that in order to successfully plan and conduct a teaching for a particular group of learners in a specific context, teachers should be able to interact PCK components coherently (Van Driel et al., 2002; Loughran, Berry, & Mulhall, 2006). The interconnectedness among them is important for PCK development and the connections are highly complex in nature (Park & Oliver, 2008a). However, taking the long history of PCK into consideration, the nature of interactions among PCK components has been unexplored issue in teacher education literature until recently (Henze, Van Driel, & Verloop, 2008; Padilla & Van Driel, 2011; Park & Chen, 2012, Aydin, Demirdogen, Akin, Uzuntiryaki-Kondakci, & Tarkin, 2015). Little attention was paid to how PCK components interact with each other for different topics or how these interactions develop when teachers gain more teaching experience. Therefore, more studies are needed that look at how the nature, dynamics, qualities and complexities of the interactions of all PCK components in different topics, how these interactions among the components influence teaching practice, and how teachers' different levels of teaching experiences are related to these interactions.

### **1.1. Purpose of the Study**

The purpose of this study was to investigate the nature of interactions among all PCK components (science teaching orientations, knowledge of learner, knowledge of instructional strategies, knowledge of curriculum, and knowledge of assessment) of novice and experienced chemistry teachers in teaching reaction rate and chemical equilibrium topics. In addition, the role of teaching experience, if any, on the interactions among PCK components in teaching these two topics was examined.

### **1.2. Research Questions**

This study aims to answer the following research questions:

1. What is the nature of interactions among PCK components of novice and experienced chemistry teachers in teaching reaction rate and chemical equilibrium topics?
2. What is the role of teaching experience, if any, on the interactions among PCK components in teaching reaction rate and chemical equilibrium topics?

### **1.3. The Intended Audience of the Research**

Science education researchers and science teacher educators, especially in the field of chemistry education, are the intended audiences of this study. Moreover, policy makers are the other intended audience of this research.

### **1.4. Definitions of Important Terms**

The research questions of this study consist of several terms that need to be defined.

#### *Pedagogical Content Knowledge (PCK)*

PCK is defined as “the blending of content and pedagogy into an understanding of how particular topics, problems, or issues are organized,

represented, and adopted to the diverse interests and abilities of learners, and presented for instruction (Shulman, 1987, p.8).

#### *Subject Matter Knowledge*

Subject matter knowledge refers to knowledge of content in a specific field. Substantive and syntactic structures are two types of subject matter knowledge. The substantive structures refer to facts, rules, principles, organization of concepts and theories, whereas syntactic structures are the rules of proof and evidence utilized to produce and support knowledge claims in the discipline (Schwab, as cited in Tamir, 1988).

#### *Pedagogical Knowledge*

Pedagogical knowledge is not a subject-specific knowledge and is related to teacher knowledge of classroom management, learning theory, instructional strategies, etc. (Abell, 2007).

#### *Knowledge of Context*

Knowledge of context refers to knowledge of schools, communities and students' backgrounds that teacher utilize in their teaching (Abell, 2007).

#### *Science Teaching Orientations*

Science teaching orientations component of PCK is defined as teachers' knowledge and beliefs about the purposes and goals for teaching science at a specific grade level. Within the proposed PCK model for science teaching, science teaching orientations component plays a critical role because of its pivotal position which influences the other PCK components, and these components influence it (Magnusson et al., 1999).

#### *Knowledge of Science Curriculum*

Knowledge of science curriculum component consists of two categories: mandated goals and objectives, and specific curricular programs and materials. The first category includes of teachers' knowledge of goals and objectives related to their

subject(s) for students, as well as the vertical curriculum (vertical relations of the topic to the earlier and later grades) and horizontal curriculum (relations to other topics in the same grade) in their subject(s). The second category includes knowledge of the programs and materials that teachers need to teach a subject or a specific topic within that subject (Magnusson et al., 1999).

#### *Knowledge of Students' Understanding of Science*

Knowledge of students' understanding of science component refers to the teachers' knowledge about students to improve specific scientific knowledge. Knowledge of requirements for learning and knowledge of areas of student difficulty are the two categories of this component (Magnusson et al., 1999).

#### *Knowledge of Assessment in Science*

Knowledge of assessment in science component consists of two categories: knowledge of dimensions of science learning to assess and knowledge of methods of assessment. The first category refers to teachers' knowledge about assessment of students' learning as related to stated goals (e.g., conceptual understanding, nature of science, scientific investigation, etc.). The second category is related to teachers' knowledge of how to assess student learning as related to stated goals (Magnusson et al., 1999).

#### *Knowledge of Instructional Strategies in Science*

Knowledge of instructional strategies in science component includes two categories of knowledge: knowledge of subject-specific strategies and knowledge of topic-specific strategies. Subject-specific strategies are broadly implementable and particular to only teaching science. Topic-specific strategies are much narrower in extent and are used for teaching specific topics within a domain of science (Magnusson et al., 1999).

Definitions for interactions among PCK components are derived from the definitions of each component.

*Interaction between knowledge of instructional strategies and science teaching orientations* refers to utilizing a specific instructional strategy to attain goals and purposes for science teaching.

*Interaction between knowledge of instructional strategies and knowledge of learner* refers to utilizing a specific instructional strategy to handle a difficulty, misconception or pre-requisite knowledge.

*Interaction between knowledge of instructional strategies and knowledge of curriculum* refers to utilizing a specific instructional strategy to address a particular curriculum objective.

*Interaction between knowledge of instructional strategies and knowledge of assessment* refers to reviewing the instructional strategies according to the feedback taken from assessments.

*Interaction between knowledge of learner and knowledge of curriculum* refers to taking into consideration a difficulty, misconception, or pre-requisite knowledge while examining the curriculum regarding what students should have learned and will learn about those topics.

*Interaction between knowledge of learner and knowledge of assessment* refers to utilizing different assessment methods to specify students' difficulties, misconceptions or pre-requisite knowledge.

*Interaction between knowledge of learner and science teaching orientations* refers to taking into consideration students' difficulties, misconceptions or pre-requisite knowledge based on the teacher's goals and purposes for science teaching.

*Interaction between knowledge of curriculum and knowledge of assessment* refers to utilizing different assessment methods to define learners' achievement regarding the goals and objectives related to the subjects, or to bring out what students know about the topic within a grade and across grades.

*Interaction between knowledge of curriculum and science teaching orientations* refers to taking into consideration a particular curriculum emphasis in class (i.e., nature of science objectives) according to teacher's goals and purposes for science teaching.

*Interaction between knowledge of assessment and science teaching orientations* refers to assessing a particular knowledge or skill for determining whether students reached teacher's goals and purposes for science teaching.

### **1.5. Significance of the Study**

This research fulfills several gaps in literature by studying the nature of interactions among PCK components of teachers with different levels of teaching experience in teaching two different chemistry topics and draws some conclusions for science teacher education.

Review of the literature revealed that many studies endeavor to portray the PCK of science teachers; however, very few studies have addressed the relationships among PCK components as also stated by Friedrichsen, Van Driel, and Abell (2011). Those studies have examined only one or two components and the interaction between them (e.g., Veal & Kubasko, 2003; Cohen & Yarden, 2009), or the effect of the development of one component on the whole PCK and teaching practice of a teacher (e.g., Kamen, 1996). To date, few studies have been conducted to investigate the interplay among all PCK components (Henze et al., 2008; Padilla & Van Driel, 2011; Park & Chen, 2012, Aydin et al., 2015). To the best of my knowledge, how the interactions among all PCK components develop when teachers gain teaching experience has not been revealed by the previous studies yet. As a conclusion, the nature, dynamics and complexities of the interplays of all PCK components have not been fully resolved (Park & Chen, 2012). Therefore, this study is supposed to provide valuable information about the nature, dynamics and complexities of interplays among PCK components related to teaching chemistry.

Moreover, in the field of science education, so far only a few studies have focused on beginning science teachers' PCK development (Luft et al., 2011) and the comparison between beginning and experienced science teachers' PCK (Clermont, Borko, & Krajcik, 1994). In addition, those who investigate secondary science teachers are frequently interested in preservice and in-service teachers' development. Therefore, science teacher scholars have confessed that this point of view is limited,

because the induction years of novice teachers are a significant element of teacher development (Luft et al., 2011). The absence of study on beginning science teachers and the significance of highlighting the teaching of science during the first years of teaching propose that the research on novice science teachers is worthy of investigation (Luft et al., 2011). Furthermore, in the limited number of studies which described various integrations among PCK components, the subjects were mostly preservice or experienced teachers. Educational scholars pointed out the need for research on how teachers with different levels of teaching experience use PCK components coherently in order to make the topic more understandable to learners and provide significant implications for teacher education (Abell, 2008; Park & Chen, 2012), and how PCK develops over time (De Jong, Van Driel, & Verloop, 2005). It is my view that this study helps novice and experienced teachers to comprehend what PCK is and how knowing PCK may assist their teaching improve. Moreover, it is possible with the present study to draw a profile of how novice and experienced teachers integrate PCK components into their PCK. In other words, this study will make a contribution to the field of PCK by examining the role of teaching experience, if any, on the interactions among PCK components. Having such information, better preservice teacher education and professional development programs may be developed.

Another point that needs consideration is that there is a need to examine topic-specificity of PCK in different topics within the same discipline (Abell, 2008). Particularly, it is emphasized that more research is required to comprehend how novice teachers construct their general, discipline, or topic-specific PCK (Luft et al., 2011). In addition, the nature of a topic is an indicator of how and to what extent components interact with each other (Park & Chen, 2012). Therefore, the results of this study will contribute to the PCK literature by showing that the topic-specificity is based not only on which components comprise a teacher's PCK in a specific topic but also on how and to what degree those components are integrated into the PCK. Moreover, selection of the topic is another important point, because it was a well-attested fact that a significant number of high school students struggle with

understanding concepts related to reaction rate and chemical equilibrium topics (e.g., Tyson, Treagust & Bucat, 1999; Van Driel et al., 1998). Experienced teachers' rich repertoire of teaching practices regarding rate of reaction and chemical equilibrium topics and how they integrate PCK components may help other teachers develop their teaching as well. Furthermore, this study will provide a valuable example of how a novice teacher integrates PCK components and in which points s/he has problems while teaching these two specific topics. Therefore, both experienced and novice teachers' practices will be a precious source for teacher education programs as well as science teacher educators for designing effective professional development programs for science teachers.

Finally, from a methodological aspect, this study will provide valuable contributions to the PCK literature. In order to identify, quantify, and visualize the interplays among PCK components, I used PCK map approach, a pictorial demonstration of the relationships among PCK components (Park & Chen, 2012). Utilizing PCK map approach helps us designate the components that teachers lack or have but frequently have difficulty in interacting with other components for different topics within the same discipline (Park & Chen, 2012). With the help of this approach, I can compare how PCK and the interactions among the components are different for novice versus experienced chemistry teachers for different topics which will provide valuable implications for teacher education. By using PCK map approach, this study provides valuable effort to show that construction of PCK is a complicated process and this construction is primarily influenced by the relations of various components. Therefore, this is a promising study to support that emphasis should be put not only on the development of individual PCK components but also the development of integrations among the components into the PCK.

Given the importance of teachers' PCK and practice, there is a need for conceptual and methodological clarity concerning the relationship among the components as well as the role of teaching experience on these interactions. With this in mind, this study intended to investigate the nature of interactions among all PCK components of novice and experienced chemistry teachers as well as to identify

whether teaching experience is related to the interactions among PCK components. In conclusion, this study has three main powerful aspects: comparing and contrasting interplays among novice and experienced teachers' PCK components in teaching two different chemistry topics; thereby drawing a conclusion about the role of teaching experience, if any, on the interactions among PCK components; and presenting tangible examples of both novice and experienced teachers' PCK and relationships among the PCK components in these topics.



## CHAPTER 2

### REVIEW OF LITERATURE

The purpose of this study is to examine the nature of interplays among PCK components for novice and experienced chemistry teachers in teaching reaction rate and chemical equilibrium topics. Therefore, literature on conceptualization of PCK, nature of PCK, research on the interplay among PCK components, and research on how teaching experience is related to PCK development will be reviewed in this chapter.

#### 2.1. Conceptualization of Pedagogical Content Knowledge

Discussions about teachers' subject matter and pedagogy have been going on since last century. The focus of these discussions has been on seeking the answers to the questions "What are the domains and categories of content knowledge in the minds of teachers? How, for example, are content knowledge and general pedagogical knowledge related? In which forms are the domains and categories of knowledge represented in the minds of teachers? What are the promising ways of enhancing acquisition and development of such knowledge?" (Shulman, 1986, p.9). According to Shulman and his colleagues (1986), these questions were the central questions in the literature of teacher education in order to probe the complex nature of teacher understanding and transmission of content knowledge. Over that, Shulman (1986) concentrated on "Knowledge Growth in Teaching" and tried to answer those questions. He proposed to divide content knowledge into three domains; subject matter content knowledge, pedagogical content knowledge, and curricular knowledge. Subject matter knowledge refers to the amount and organization of knowledge in the mind of a teacher, and consists of substantive and syntactic structures. Substantive structure of a discipline refers to the organization of concepts, facts, principles and theories, while syntactic structure refers to the rules of evidence and proof utilized to produce and validate knowledge claims in the discipline.

Curricular knowledge refers to teachers' knowledge about program and materials for the teaching of specific subjects and topics, as well as lateral curriculum (teachers' ability to link the content of a course to topics being discussed concurrently in other classes, and vertical curriculum (topics in the preceding and later years that are associated to the topics that are taught). PCK was depicted as a kind of teachers' special practical knowledge as well as a special amalgam of content and pedagogy (Shulman, 1986). PCK goes beyond subject matter knowledge for teaching. Shulman identified PCK as

...for the most regularly taught topics in one's subject area, the most useful forms of representation of those ideas, the most powerful analogies, illustrations, examples, explanations, and demonstrations-in a word, the ways of representing and formulating the subject that make it comprehensible to others (Shulman, 1986, p.9).

Moreover, that area of knowledge consists of "...an understanding of what makes the learning of specific topics easy or difficult: the conceptions and preconceptions that students of different ages and backgrounds bring with them to the learning of those most frequently taught topics and lessons" (Shulman, 1986, p.9). In 1987, Shulman carried his research on knowledge and teaching in order to respond four questions: "What are the sources of the knowledge base for teaching? In what terms can these sources be conceptualized? What are the processes of pedagogical reasoning and action? and What are the implications for teaching policy and educational reform?" (p.1). Then, he offered seven categories of knowledge bases in order to increase understanding of students, three of which are content related (i.e., content knowledge, PCK, and curriculum knowledge), and the others refer to general pedagogy (i.e., learners and their characteristics, educational contexts, and educational ends, purposes and values). They can be outlined as: i) content knowledge; ii) general pedagogical knowledge, with special reference to those broad principles and strategies of classroom management and organization that appear to transcend subject matter; iii) curriculum knowledge, with particular grasp of the materials and programs that serve as "tools of the trade" for teachers; iv) pedagogical content

knowledge, that special amalgam of content and pedagogy that is uniquely the province of teachers, their own special form of professional understanding; v) knowledge of learners and their characteristics; vi) knowledge of educational contexts, ranging from the workings of the group or classroom, the governance and financing of school districts, to the character of communities and cultures; and vii) knowledge of educational ends, purposes, and values, and their philosophical and historical grounds (p.8). Shulman (1987) pointed out that PCK, among those categories, requires a special interest since it designates a mixture of content and pedagogical knowledge for teaching a particular topic for diverse interests and abilities of learners.

In following years, elaborating on Shulman's work, many scholars carried out research on PCK, as a construct of teacher knowledge. For example, Tamir (1988), who was influenced by Shulman's view, made an attempt to outline a framework for teacher knowledge. This framework includes six main categories; namely, general liberal education (basic skills of reading, mathematics, writing, and reasoning), personal performance, subject matter, general pedagogical, foundations of the teaching profession (history and policy; philosophy and psychology; cultural and cross-cultural factors; professional ethics), and subject matter specific pedagogical knowledge, which is indeed PCK. Tamir (1988) claimed that general pedagogical knowledge and subject matter specific pedagogical knowledge were very different from each other. He argued that;

The distinction is very important with regard to teacher education, since, while the first (i.e., general pedagogy) may be handled by experts in general pedagogy and, hence, can be taught in mixed disciplinary classes, the second (i.e., subject matter specific pedagogical knowledge) must be handled by instructors who are pedagogical experts in a particular discipline working with student teachers preparing to teach in that discipline (p.100).

Tamir (1988) conceptualized PCK with four components by defining and distinguishing knowledge and skill for each component: knowledge of student, curriculum, instruction (teaching and management) and evaluation. Knowledge of

student consists of particular conceptions and misconceptions (knowledge) as well as how to identify a student conceptual difficulty in a given topic (skill). Knowledge of curriculum includes prerequisite concepts required for understanding photosynthesis (knowledge), and how to plan an inquiry oriented laboratory lesson (skill). Knowledge of instruction consists of a laboratory lesson with three phases: pre-lab discussion, performance, and post-laboratory discussion (knowledge), and how to teach learners to utilize a microscope (skill). Finally, knowledge of evaluation involves the nature and composition of the Practical Tests Assessment Inventory (knowledge), and how to evaluate manipulation laboratory skills (skill). Different from Shulman's (1986) PCK conceptualization, the distinction between knowledge and skill, and addition of evaluation component in the Tamir's (1988) PCK framework were the most important points for teacher education.

Then, Grossman (1990) examined the nature and sources of PCK of three beginning English teachers who entered teaching without professional preparation and three graduates of a fifth-year teacher education program. She suggested more extensive delineation of the knowledge bases and came up with a model of teacher knowledge with four essential components; in other words, cornerstones of the emerging work on professional knowledge for teaching, which are: subject matter knowledge, general pedagogical knowledge, PCK, and knowledge of context (see Figure 2.1). Double arrows in the model depict the relationship between PCK and the other domains of knowledge for teaching.

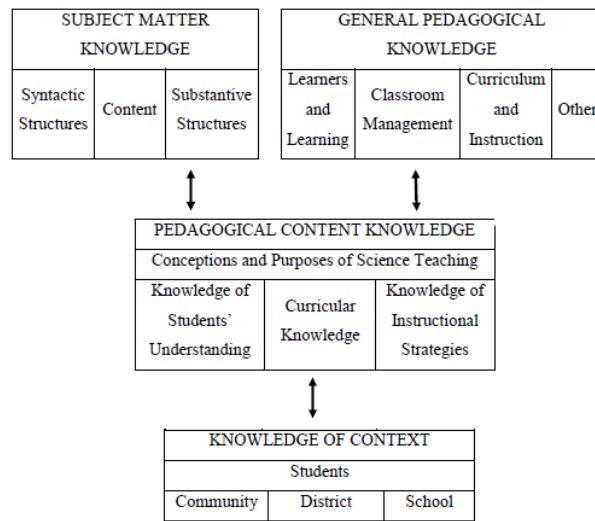

**Figure 2.1** Model of Teacher Knowledge (Grossman, 1990, p.5)

Grossman (1990) also broadened Shulman's model by adding four distinct components into PCK. The first component, an overarching component of PCK, includes knowledge and beliefs about the purposes for teaching a subject at different grade levels. This component influences the teachers' decisions of instructional strategies, as well as their PCK. The second component of PCK refers to knowledge of learners' understanding, conceptions, and misconceptions of particular topics in a subject matter. Teachers should have some knowledge about students' pre-requisite knowledge and difficulties in a topic to produce suitable explanations and representations. The third component of PCK, curricular knowledge, is composed of knowledge of curriculum materials and knowledge about both the horizontal and vertical curricula for teaching a specific subject matter. The last component of PCK consists of instructional strategies and representations for teaching specific topics. Grossman (1990) advocated that these PCK components were less separate from each other in practice than in theory. Unlike Tamir (1988), Grossman did not focus on assessment as a component of PCK. Regarding the sources of PCK, Grossman proposed four potential sources for developing PCK: apprenticeship of observation, disciplinary background, professional coursework, and learning from experience.

Later, based on a constructivist view of teaching, Cochran, King and DeRuiter (1991) delineated PCK as an integrated knowledge and synthesized from four areas of teacher knowledge; namely, subject matter knowledge, pedagogical knowledge, knowledge of the environmental context, and knowledge of students. With this view of teaching, PCK refers to the comprehension of learning processes, subject matter concepts, and approaches for teaching the particular content of a discipline in a way that facilitates learners to build their own knowledge successfully in a given context. They highlighted that “the four separate knowledges are transformed and synthesized as PCK evolves, and theoretically, the four components become so integrated and so interrelated that they no longer can be considered separate knowledges” (p.12). Different from Shulman’s conceptualization, they put more emphasis on the teacher’s knowledge of students and environmental context of learning. Afterwards, in the light of their constructivist view of learning and teaching processes, Cochran, King and DeRuiter (1993) proposed a new model, Pedagogical Content Knowing (PCKg), which was an expanded version of earlier PCK model (see Figure 2.2). This idea was based on a dynamic nature, and put emphasis on knowing and understanding as active processes and on simultaneous improvement of all perspective of knowing how to teach (Cochran et al., 1993).

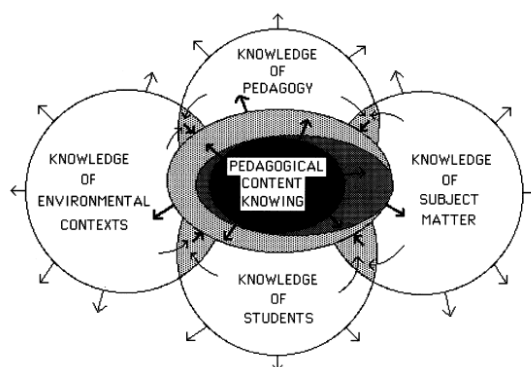

**Figure 2.2** Cochran et al.’s (1993) PCK model

While Shulman’s PCK conceptualization focuses on the transformation of subject matter for teaching, PCKg model emphasizes that teachers should enhance their pedagogical and subject matter knowledge in the context of teachers’

understandings of learner and of the environmental context. They offered that teachers' understanding of students and of the environmental context gives a shape to the teaching and learning process, because learning is created by the learner in a learning setting. Therefore, these two aspects of teachers' understanding ensure a basis for teaching process. As indicated with the overlapping circles, PCKg model is formed with the integration of the four components of pedagogy, subject matter content, students' characteristics, and the environmental context of learning. In addition, the dark arrows and expanding core of the model represents the development of knowledge. Similarly, Fernandez-Balboa and Stiehl (1995) conceptualized PCK based on the idea of interaction among PCK components. These authors investigated "generic" nature of PCK of university professors in a qualitative research approach. Data were collected through phenomenological interviews with 10 professors who were teaching at different areas (e.g., biology, business, special education, etc.). The method of constant-comparison was utilized for data analysis. Qualitative analysis of data put forward 5 generic PCK components, which were: knowledge of subject matter, students, instructional strategies, teaching context, and one's teaching purposes. They did not offer a PCK model presenting the components, and also their PCK conceptualization did not include knowledge of assessment.

Gess-Newsome (1999) made a different attempt to understand the nature of teacher knowledge by suggesting two models of for PCK: the integrative and transformative models (see Figure 2.3). In order to differentiate them, Gess-Newsome utilized a 'mixture versus compound' analogy. The integrative model pointed that PCK does not exist and the intersection of three knowledge domains (i.e., pedagogy, subject matter, and context) describes teacher knowledge. Accordingly, teaching can be explained as the act of integrating knowledge of these three knowledge domains (Gess-Newsome, 1999). This model is similar to the formation of a mixture. The ingredients of mixture still possess their own properties, although their visual impact may imply a total integration. On the other hand, in the transformative model, PCK is formed as a synthesis of all knowledge base for teaching, as in the formation of a chemical compound in which the ingredients lose

their initial properties. “While knowledge bases containing subject matter, pedagogy, and context exist, they are latent resources in and of themselves and are only useful when transformed into PCK.” (Gess-Newsome, 1999, p. 12)

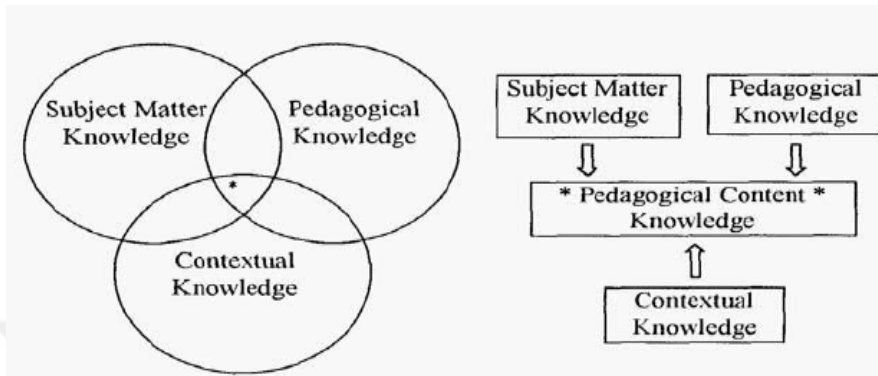

\* = knowledge needed for classroom teaching (Gess-Newsome, 1999, p. 12)

**Figure 2.3** Integrative model and transformative models of PCK

Taking a somewhat different perspective, Magnusson et al., (1999) propose a refined PCK model in a specific discipline, which is ‘*science.*’ Actually, Magnusson and his colleagues’ model is grounded in the work of Grossman (1990) and Tamir (1988). Similar to Grossman, they view PCK as a result of transformation of knowledge of subject matter knowledge, pedagogical knowledge, and knowledge of context. Figure 2.4 shows the model of the relationship among these major teacher knowledge domains and it was first proposed by Grossman. Similarly, double arrows in the model show the reciprocal relationship between PCK and the other domains of knowledge for teaching.

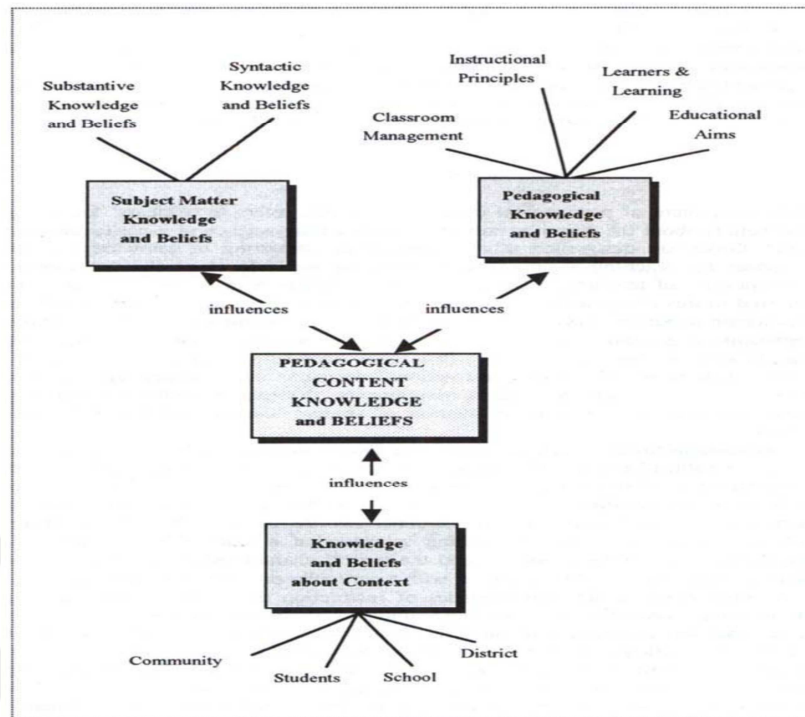

**Figure 2.4** A model of the relationships among the domains of teacher knowledge modified from Grossman (1990) (Magnusson et al., 1999, p.98)

In Magnusson et al.'s (1999) PCK model for science teaching, they changed Grossman's *purposes* to *orientations* and added the knowledge of assessment component, similar to Tamir's (1988). Eventually, their PCK model consists of five components (a) orientations toward science teaching, (b) knowledge and beliefs about science curriculum, (c) knowledge and beliefs about students' understanding of specific science topics, (d) knowledge and beliefs about assessment in science, and (e) knowledge and beliefs about instructional strategies for teaching science (see Figure 2.5).

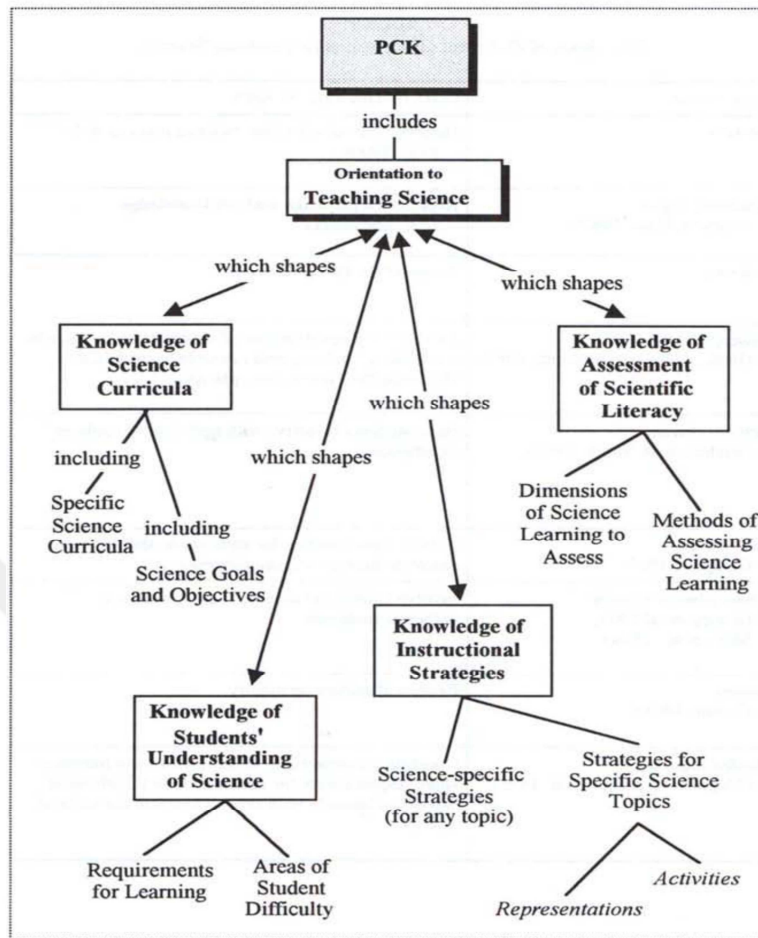

**Figure 2.5** Components of PCK for science teaching (Magnusson et al., 1999, p.99)

The components of the Magnusson et al.'s (1999) PCK model were summarized below:

Science teaching orientations component of PCK is defined as teachers' knowledge and beliefs about the purposes and goals for teaching science at a specific grade level. Within the proposed PCK model for science teaching, science teaching orientations play a critical role because of its pivotal position which influences the other PCK components (Magnusson et al., 1999). Science teaching orientations, general way of viewing or conceptualizing science teaching, directs teachers' planning, enacting and reflecting upon teaching. Magnusson et al. (1999) identified nine teaching orientations as explained in Table 2.1.

**Table 2.1** The goals of different orientations to teaching science

<b>Orientations</b>	<b>Goals of teaching science</b>
Process	Help learners improve science process skills
Academic rigor	Present a specific body of knowledge (e.g., physics)
Didactic	Transfer the facts of science
Conceptual change	Ease the improvement of scientific knowledge by contradicting learners with contexts to clarify that challenge their naive conceptions
Activity-driven	Make learners active with materials and hands-on experiences
Discovery	Supply opportunities for learners to discover aimed science concepts on their own
Project-based science	Include learners in examining solutions to authentic problems
Inquiry	Present science as inquiry
guided inquiry	Found a community of students whose members share responsibility for comprehension the physical world, especially with respect to utilizing the tools of science

Knowledge of science curriculum component is comprised of two categories: mandated goals and objectives, and specific curricular programs and materials. Wilson, Shulman and Richert (1988) designated curricular knowledge as a separate teaching knowledge domain. However, based on the Grossman's (1990) view, Magnusson et al. (1999) defined it as a component of PCK. Similar to Grossman's (1990) definition, the first category consists of teachers' knowledge of goals and objectives related to their subjects for students, as well as the vertical curriculum (vertical relations of the topic to the earlier and later grades) and horizontal curriculum (relations to other topics in the same grade) in their subjects. The second category includes knowledge of the programs and materials that teachers need to teach a subject or a specific topic within that subject.

Knowledge of students' understanding of science component refers to the teachers' knowledge about students in order to assist them to improve specific scientific knowledge. Knowledge of requirements for learning and knowledge of areas of student difficulty are the two categories of this component. The first category refers to the teachers' knowledge about prerequisite knowledge needed for students in order to learn particular scientific topics. Additionally, teachers' knowledge of variations in terms of students' developmental and ability levels or different learning styles is under the first category. A successful teacher knows students' requirements and needs for learning the topic, and how students should learn that topic best. The second category refers to areas of difficulty for student learning. Teachers should be knowledgeable about the science concepts or topics that students find difficult to learn and the reasons for that (e.g., abstract nature of topic, misconception, etc.).

Following Tamir (1988), Magnusson et al. (1999) defined knowledge of assessment in science as a PCK component. It consists of two categories: knowledge of dimensions of science learning to assess and knowledge of methods of assessment. The first category consists of teachers' knowledge about assessment of students' learning as related to stated goals (e.g., conceptual understanding, nature of science, scientific investigation, etc.). The second category is related to teachers' knowledge of how to assess student learning as related to stated goals. Teachers' knowledge of methods of assessment consists of knowledge of particular instruments or procedures, approaches or activities such as written tests, portfolios, and poster presentations. Effective teachers should be knowledgeable about which methods of assessment are more appropriate for assessing some aspect of learning than others, as well as the advantages and disadvantages of certain assessment techniques.

Knowledge of instructional strategies component includes two categories of knowledge: knowledge of subject-specific strategies and knowledge of topic-specific strategies. The difference between these two strategies is their scope. Subject-specific strategies are broadly implementable and particular to only teaching science. This category is comprised of general approaches to instruction such as learning

cycles, conceptual change, and inquiry-oriented instruction and they are consistent with the goals of specific science teaching orientations. The second category, topic-specific strategies, is much narrower in extent and is used for teaching specific topics within a domain of science. Topic specific strategies consist of representations (e.g., illustrations, models, analogies or examples) and activities (e.g., simulations, demonstrations, or experiments) that are used for helping students comprehend specific concepts or relationships. Therefore, teachers should know when and how to integrate them in their instructions.

Magnusson et al. (1999) summarized that their PCK model put forward several important ideas about PCK. First, PCK components designate that there are various types of subject-specific pedagogical knowledge that are utilized in teaching science. For each component, teachers have particular knowledge determined by the topic. Second, teachers should enhance all components of PCK in all topics they teach for an effective teaching. Third, the coherence among PCK components is critical in improving PCK and growth of a single component may not be enough for a change in teachers' practice. Last, the components might integrate into PCK in highly complex ways; thus, it is essential to comprehend how the components interplay, and how their interplays affect teachers' practice.

In conclusion, Magnusson et al.'s (1999) conceptualization of PCK ensures a significant tool for science teachers in order to build the particular knowledge to be effective teachers. Although Magnusson et al.'s (1999) model represented the five components in a linear way, it implies the significance of the interplay and harmony among the components. However, the only explicit interaction in this model is between science teaching orientations and each of the other four components.

All the efforts, until now, describing PCK mostly concentrated on what forms the PCK. Prior to the study of Veal and MaKinster (1999), there has not been an explicit consideration and clarity about the nature of PCK. Veal and MaKinster (1999) classified PCK as taxonomies (i.e., classification system) by showing hierarchical relationships among PCK components different from the previous PCK models. They developed General Taxonomy of PCK which classified different kinds

of PCK previously discussed in the literature and add a new category of PCK (i.e., topic-specific PCK) (see Figure 2.6).

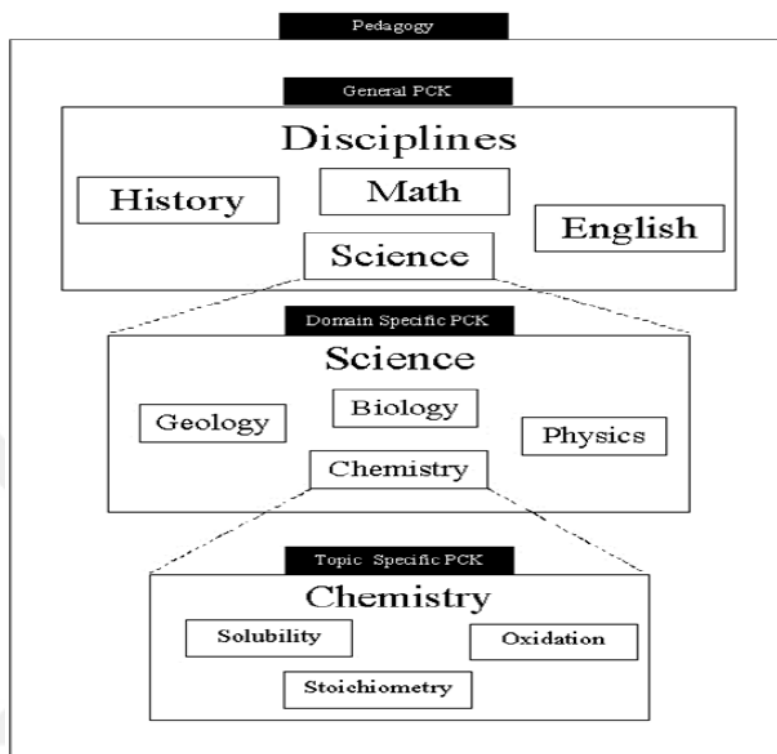

**Figure 2.6** General Taxonomy of PCK proposed by Veal and MaKinster (1999, p.7)

This taxonomy defined general teaching skill and pedagogy that should be enhanced by all teachers. These pedagogical strategies consisted of planning, teaching methods, evaluation, feedback, lecture, and etc. These strategies were not specific to any content area, and could be utilized in different content areas. The first level of this taxonomy is general PCK which is more specific than pedagogy, since the concepts and strategies used were particular to different disciplines such as science, math, history or English. General PCK is related to science as a subject and is similar to subject-specific strategies defined by Magnusson et al. (1999). Domain-specific PCK, the second level, is more specific than general PCK, since it concentrates on one of the domains (e.g., biology) under a specific discipline (e.g., science). Topic-specific PCK is the most specific level of the taxonomy. A teacher

who has topic-specific PCK could possess the general and domain-specific PCK. Not only the concepts in a specific domain may be taught differently, but also the common concepts are also taught differently in many cases. For instance, a chemistry teacher may use kinetic molecular theory to explain temperature, while a physics teacher may explain it as the measure of heat lost or gained in a system (Veal & MaKinster, 1999). Although this concept is covered by both domains (physics and chemistry), teaching and representations of the concept show differences. Moreover, the authors of this study proposed the Taxonomy of PCK Attributes (see Figure 2.7) to represent hierarchical structure of PCK and its attributes. According to this structure, PCK has a central position which shows that its significance and the surrounding attributes are all related, indicating an integrated nature of components. Moreover, a solid content background is required to the improvement of PCK. Knowledge of students is the second essential attribute for developing PCK. Knowledge of students has more importance than pedagogical knowledge in this taxonomy. Furthermore, the attributes of PCK are inter-related instead of being linear. Teachers can have or improve one of attributes of PCK at any time throughout their teaching career. Therefore, the improvement of one may simultaneously induce the improvement of others.

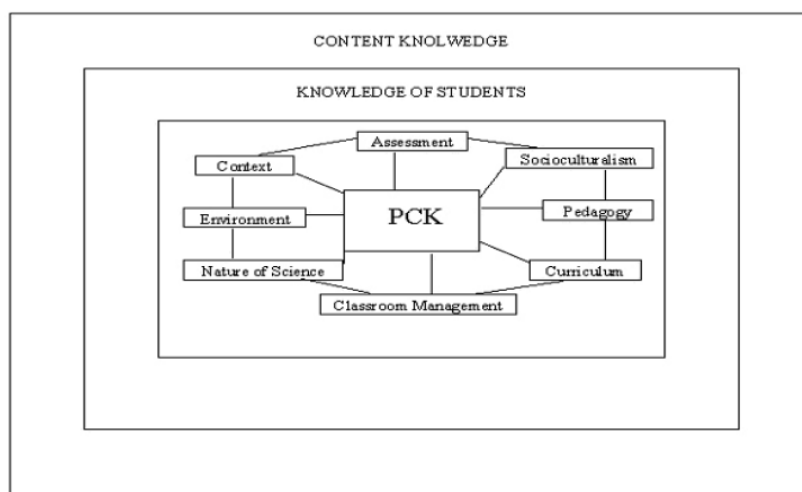
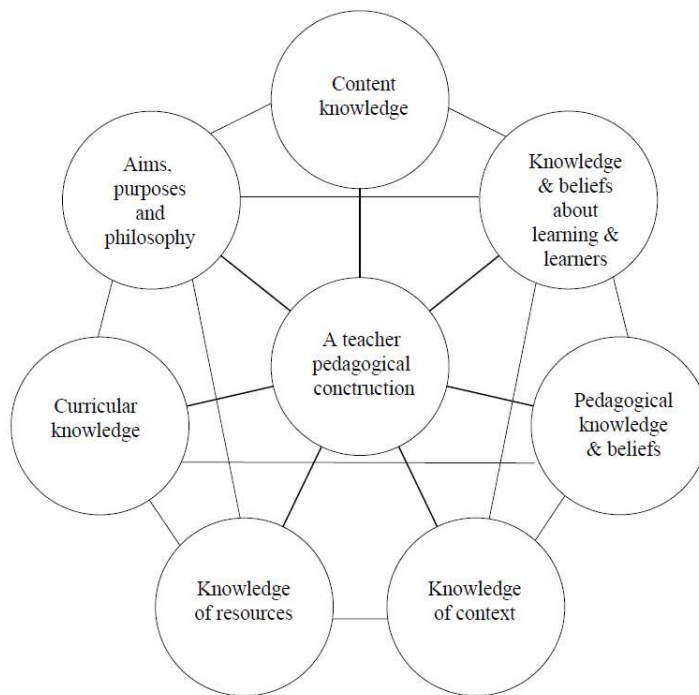

**Figure 2.7** Bird's Eye View of Taxonomy of PCK Attributes (Veal & MaKinster, 1999, p.11)

After the work of Veal and MaKinster (1999), Hashweh (2005) criticized the conceptualization of PCK and pointed out the lack of clarity about the nature of PCK, its components and development and its generality or specificity. He also drew attention to the relation between teacher knowledge and beliefs. Taking the results of recent research on PCK in addition to his own and Shulman's conceptualization of PCK into consideration, Hashweh (2005) proposed a new term, "teacher pedagogical constructions (TPCs)" instead of PCK. He stated that PCK is

...the set or repertoire of private and personal content-specific general event-based as well as story-based pedagogical constructions that the experienced teacher has developed as a result of repeated planning and teaching of, and reflection on the teaching of, the most regularly taught topics (2005, p.277).

Based on this definition, he proposed several assertions: i) PCK is specific to a person; ii) PCK consists of a collection of teacher pedagogical constructions; iii) Teacher pedagogical constructions stem from planning, interactive and post-active phases of teaching; iv) Pedagogical constructions proceed from a distinctive process that is affected by interplay of knowledge and beliefs from various categories; v) Pedagogical constructions include a generalized event-based and a story-based kind of memory; vi) Pedagogical constructions are specific to topic; vii) There should be connections between these constructions and other categories teacher knowledge and beliefs. He proposed a model of a hypothetical science teacher's knowledge and beliefs (see Figure 2.8), which shows the interactions among different categories of teacher knowledge and beliefs.



**Figure 2.8** Model of a hypothetical science teacher's knowledge and beliefs  
(Hashweh, 2005, p. 282)

Similarly, given the importance of the interactions among the PCK components, Park and Oliver (2008a, 2008b) put PCK components into a pentagonal form with PCK in the center to show its potential improvement from any of these five components (see Figure 2.9). Their PCK model was constructed based on the work of Grossman (1990), Tamir (1988), and Magnusson et al. (1999), and consisted of the same five components as Magnusson et al.'s (1999) PCK model.

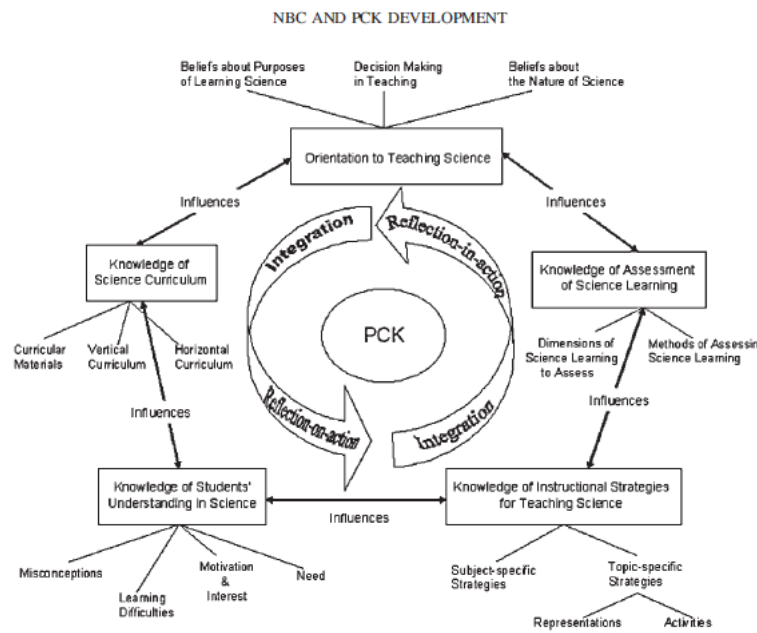
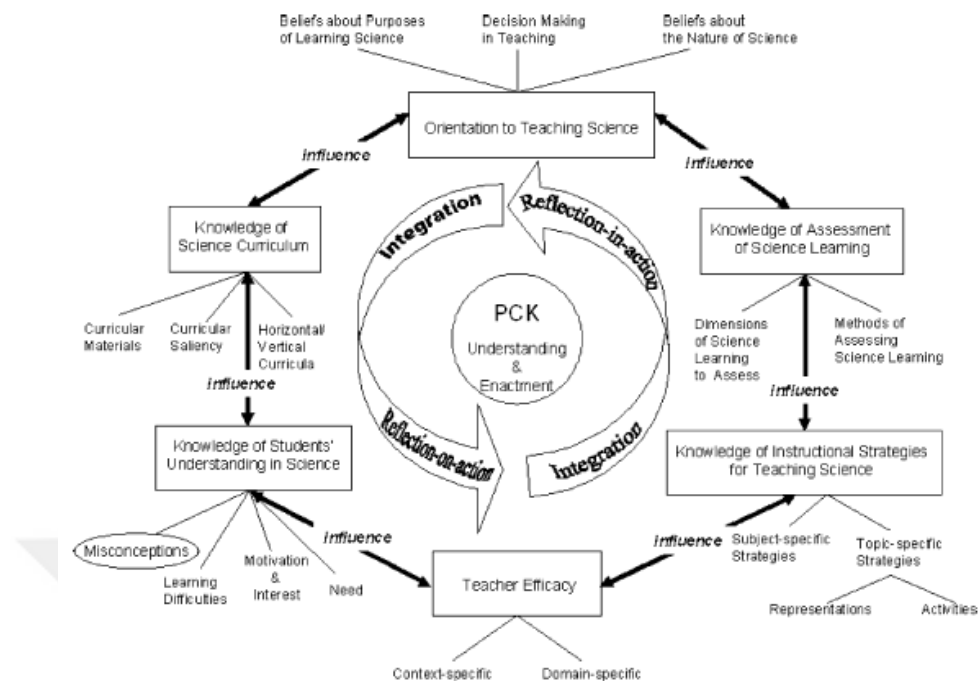

**Figure 2.9** Pentagon model of PCK for science teaching (Park & Oliver, 2008b, p. 815)

Park and Oliver (2008a) defined PCK based on two dimensions; namely, teachers' understanding and enactment. PCK is the teachers' understanding and enactment of how to support a group of learners comprehend a particular subject matter utilizing several instructional strategies, representations and assessments while working within contextual, cultural and social boundaries in the learning environment.

In order to re-examine the construct of PCK, Park and Oliver (2008a) conducted a multiple case study of three experienced high school teachers who were working in the same high school. They gathered data from classroom observations, semi-structured interviews, lesson plans, teachers' written reflections, students' work samples and researcher's field notes. The data were analyzed through three different approaches which were constant comparative method, enumerative approach and in-depth analysis of explicit PCK. Results offered a new component and some new features of PCK. One new feature of PCK came into view from identification of the synthetic and synergistic effect of both knowledge-in-action and knowledge-on-

action on PCK. Knowledge-in-action refers to knowledge enhanced and enacted while teaching by reflection-in-action, and knowledge-on-action refers knowledge elaborated and enacted after the teaching practice by reflection-on-action (Schon, as cited in Park & Oliver, 2008a). PCK had both of these aspects, and they affected each other through reflection inside or outside of classroom. This reciprocity implied that PCK growth incorporated knowledge acquisition and knowledge use. They were interrelated during instructional practices rather than following the order of acquisition and enactment. Actually, their research was conceptually based on five components of PCK; however, one new affective component of PCK, teacher efficacy, came out as a result of their research. They observed that teacher efficacy played an important role in the enactment of PCK, for instance, in portraying problems and deciding teaching strategies to solve the problems. Teacher efficacy also had a function to link understanding and enactment. Higher teacher efficacy induced encouragement for teachers to enact their understanding. When teachers performed successfully, teacher efficacy increased. Stein and Wang stated that “The increased teacher efficacy renders the teachers ready to learn relative to any of the components of PCK, whereby their understanding is expanded” (as cited in Park & Oliver, 2008a). Therefore, there is a link between teacher efficacy and PCK (Park & Oliver, 2008a). Moreover, they advocated that students’ questions, critical thinking, verbal/nonverbal responses, and evidence of learning influenced PCK. They also concluded that PCK was idiosyncratic. Orientations to science teaching, characteristics of students, teaching experiences, and personal characteristics shaped the idiosyncrasies of teachers’ PCK. These results led the researches to reorganize knowledge and propose an evolved PCK model as shown in Figure 2.10.

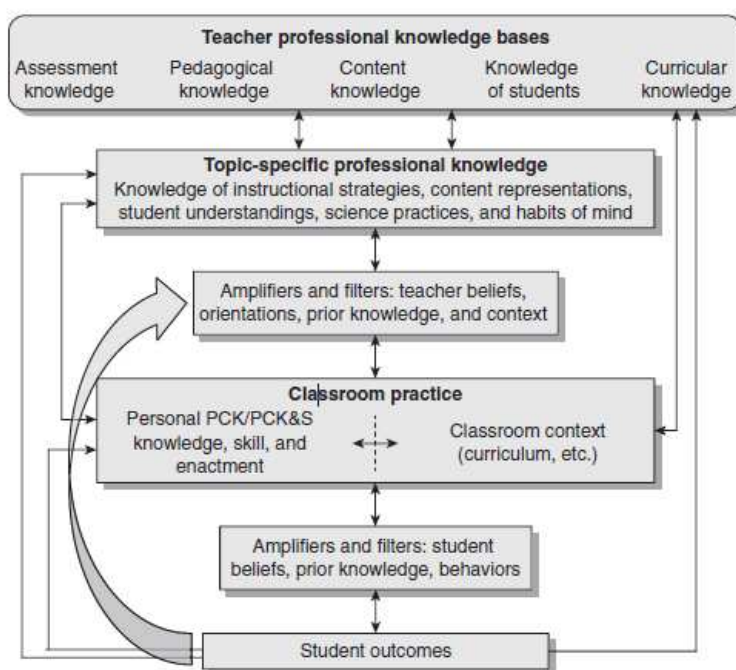

**Figure 2.10** Hexagon model of PCK for science teaching (Park & Oliver, 2008a, p. 279)

According to this model, PCK includes both teachers' understanding of how to teach subject matter knowledge effectively and the enactment of their understanding. This model also covers reflection-in-action and reflection-on-action synergistically that influence PCK development in knowledge-in-action and knowledge-on-action. Furthermore, at the beginning of the study, the authors put the five components into a pentagonal form; however, the data showed the existence of teacher efficacy as a component of PCK. Additionally, the six components affect each other, and teachers should integrate and enact them for effective teaching. The growth in one component of PCK may concurrently endorse the growth of others and eventually develop the overall PCK. On the other hand, lack of coherence among the components can be problematic in enhancing and utilizing PCK (Park & Oliver, 2008a). Regarding knowledge of students' understanding, this model also includes learners' motivation and interest as a sub-component. Apart from these additions,

this hexagon model encompasses the same components as Magnusson et al.'s (1999) PCK model.

Finally, a recent model proposed by Gess-Newsome and her colleagues (2015) is relatively different from the one originally introduced by Magnusson et al. (1999). In order to identify a unified PCK model, and find out the connections between PCK and other knowledge domain, classroom practice and/or student outcomes, they first reached a consensus on five weaknesses with PCK designated by Shulman (as cited in Gess-Newsome, 2015). These weaknesses with PCK are the absence of affect, emotion, and motivation; an overemphasis on teacher thinking versus a teacher's skilled performance in the classroom; the omission of context; the omission of a teacher's vision and goals for education; and, the relationship of PCK to student outcomes. After a long debate, they proposed a model named 'teacher professional knowledge and skill' (TPK&S) that portrays the overarching role of teacher professional knowledge bases (TPKB) and includes PCK (see Figure 2.11).



**Figure 2.11** Model of teacher professional knowledge and skill including PCK and influences on classroom practice and student outcomes (Gess-Newsome, 2015, p.31)

TPKB consists of assessment, content, students, curricular and pedagogical knowledge. “Teachers are seen as the consumers of this knowledge as translated for use in teacher education programs or professional development” (Gess-Newsome, 2015, p.32). It is a professional knowledge and not content specific. It can also be utilized to make assessments to decide what teachers know. In this model, knowledge from TPKB informs and is informed by topic-specific professional knowledge (TSPK). Gess-Newsome (2015) stated that this new category of knowledge provides several things. First, it makes obvious that content of teaching happens at the topic level (e.g., gases, solutions, etc.) and not at the disciplinary level (e.g., chemistry or science). Second, this knowledge mixes subject matter, pedagogy and context. Third, it is acknowledged as public knowledge, or knowledge held by the profession, letting it to presume a normative role. Contrary to the rest of the model, these two knowledge bases (TPKB and TSPK) are context free. Regarding TSPK, it is not only topic-specific but also specific to a learner developmental level in most cases. TSPK requires deciding effective instructional strategies; selecting multiple representations; regulating content to utilize particular examples to emphasize and construct overarching notions; comprehension learners’ misconceptions; and knowing how science and engineering practices interact, cross-setting concepts, and the nature of science in a topic (Gess-Newsome, 2015). TSPK is similar to the knowledge that has been formerly incorporated within PCK except an important difference. TSPK is not individual knowledge, is comparatively more dynamic, and is more difficult to define definitely. According to Gess-Newsome (2015), “TSPK is canonical, generated by research or best practice, and can have a normative function in terms of what we want teachers to know about topic- and context-specific instruction” (p.33). Furthermore, according to the TPK&S model, teacher affect such as motivation, dissatisfaction, efficacy, or risk-taking makes a contribution to teacher knowledge, skill and practice. Teacher affect can have an effect on what a teacher learns and prefers to apply in practice. In brief, these beliefs and orientations function as amplifiers or filter to learning of teaching, and intervene in teacher actions. Different from the other PCK model (e.g., Magnusson et al., 1999),

teacher orientations and beliefs are removed from PCK and put as an amplifier or filter for classroom practice in TPK&S model. Moreover, unique to this model, the idea of pedagogical content knowledge and skill (PCK&S) is defined as "...both a knowledge base used in planning for and the delivery of topic-specific instruction in a very specific classroom context, and as a skill when involved in the act of teaching" (Gess-Newsome, 2015, p.30). In the original conceptualization, PCK is the implementation of knowledge to teaching. However, PCK&S model put emphasis on what a teacher does in the classroom based on their PCK and skill. Two critical points were obvious. First, a teacher's knowledge about something does not imply that it would be transformed into practice when taking the teacher amplifiers and filters into consideration. Second, even if a teacher notices a proper instructional act, s/he may not possess the skill to apply it effectively. In addition, student outcomes as well as student amplifier and filters are specified explicitly in this model, which is different from earlier models. It is pointed out that student amplifiers and filters influence the results of outcome practices, because learning of students is not an automatic result of the instruction. Student success is affected by demographics (age, gender, race, native language, ethnicity); intelligence and working memory; background knowledge and misconception; motivation, self-regulation, ability to pay attention; self-concept and goal-orientation; health, nutrition, and level of physical activity; and school attendance. Finally, the TPK&S model has a repetitive and dynamic nature. Student outcomes and classroom practices have an influential role in informing further classroom practice, TSPK, and the TPKB.

In conclusion, taking the long history of PCK into the consideration, it can be inferred that PCK is an essential construct for teacher education. While the teacher education research base improves, PCK definitions and PCK models shows important differences. After Shulman's introduction of PCK, scholars have elaborated and expanded the concept by adding or integrating different components, particular labels or definitions of these components. It can be concluded that there is no universally accepted conceptualization of PCK. Despite numerous conceptualizations of PCK with different components, most researchers agreed on

Shulman's (1986) two PCK components which are knowledge of representations of subject matter and understanding of specific learning difficulties. Furthermore, there appears to be an agreement on the many aspects of the nature of PCK. In the following part, the nature and characteristics of PCK based on the existing literature is portrayed.

## **2.2. The Nature and Characteristics of PCK**

First of all, a common view of PCK is that it is a critical element of teacher knowledge, and is defined as a special combination of content and pedagogy in the minds of teachers for teaching a specific topic. Bucat (2005) stated that there is a big difference between having knowledge about a topic (i.e., content knowledge) and knowledge about the teaching and learning of that topic (i.e., pedagogical content knowledge). Similarly, Cochran et al. (1991) argued that it pertains to the way in which teachers link their pedagogical knowledge (what they know about teaching) to their subject matter knowledge (what they know about what they teach) for the teaching of particular learners in a school context. It is the integration or the synthesis of teachers' pedagogical knowledge and their subject matter knowledge that compose PCK (Cochran et al., 1991). Therefore, PCK is different from both pedagogical knowledge and subject matter knowledge. PCK is both an external and internal concept, because it is formed by what a teacher knows, what a teacher does, and the causes for the teacher's acts (Baxter & Lederman, 1999). This particular knowledge distinguishes teachers from subject matter specialist (Shulman, 1986; Cochran et al., 1991; Magnusson et al., 1999). To illustrate, a chemistry teacher differs from a chemist, not necessarily in the quality or quantity of their subject matter knowledge, but in how that knowledge is regulated and utilized.

Moreover, although some of the PCK models that I discussed fit Gess-Newsome's integrative definition, PCK is commonly believed to be a transformation rather than a blend of knowledge for the purpose of teaching, coming from subject matter knowledge, general pedagogical knowledge and knowledge of context (Grossman, 1990; Gess-Newsome, 1999; Magnusson et al., 1999). Even though

Magnusson et al., (1999) represented PCK as a separate construct, they underlined that the boundaries between knowledge domains are blurred rather than clear distinctions. Figure 2.4 shows that each knowledge domain influences the improvement of PCK. However, they stated that different knowledge domains might unequally affect the improvement of PCK because of the diversities in the amount of knowledge for each domain (see Figure 2.12). In this figure, the size of the box shows the amount of knowledge in a domain, and the thickness of the lines connecting the domains represents their relative impact each other. For example, Teacher A has much more subject matter knowledge than the other two types of knowledge. This may imply that his/her subject matter knowledge mostly influence his/her improvement of PCK. On the other hand, because of Teacher B's dominant pedagogical knowledge, his/her PCK is influenced primarily by his/her pedagogical knowledge. "These differences may mean that if these teachers taught the same topics in the same educational context, they would develop different pedagogical content knowledge, but we would expect there to be significant overlap in the knowledge developed by each" (Magnusson et al., 1999, p. 118).

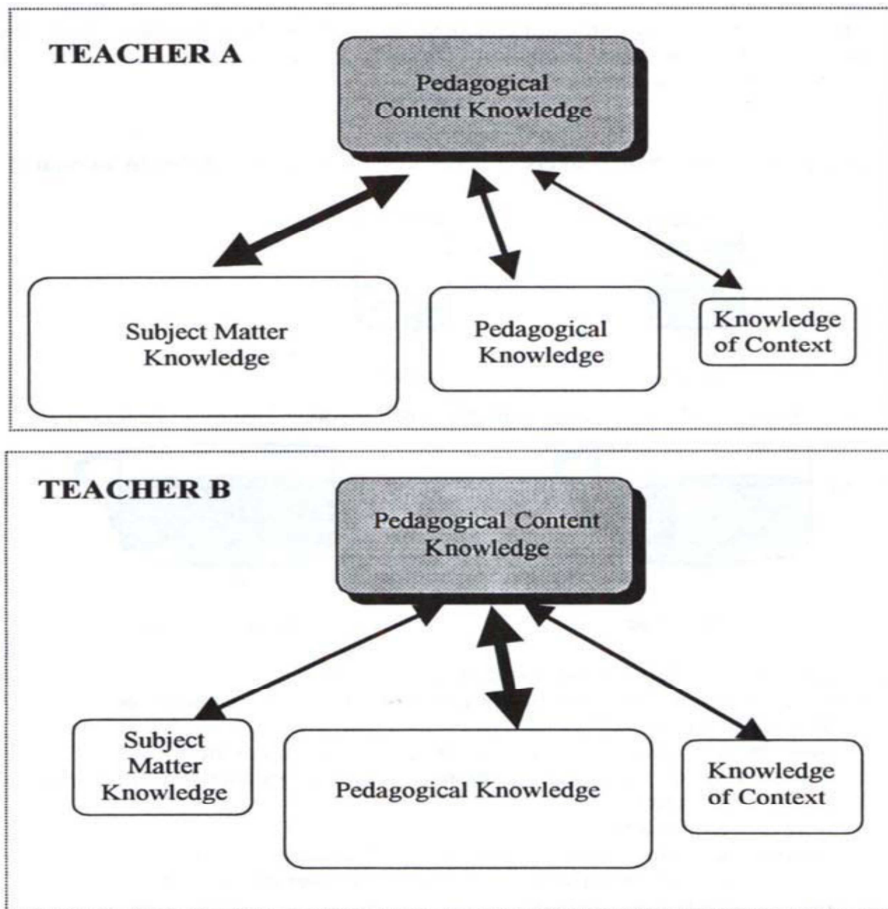

**Figure 2.12** A model illustrating differential influences of the development of PCK for two hypothetical teachers (Magnusson et al., 1999, p.119)

It should also be stressed that adequate subject matter knowledge is a prerequisite for PCK development (Van Driel, Verloop, De Vos, 1998; Abell, 2007; Kind, 2009). Van Driel et al. (1998) emphasized that an understanding of subject matter acts as a prerequisite, leading the growth of PCK. Likewise, subject matter knowledge is a critical factor for the development of PCK (Nilsson, 2008). However, Lee et al. (2007) pointed out that strong subject matter knowledge does not necessarily lead to the PCK growth. Similarly, Magnusson et al. (1999) stated that

Despite this claim of the dependence of the development of this aspect of pedagogical content knowledge on subject matter knowledge, we caution an inference that teachers will necessarily develop desired pedagogical content

knowledge if they have sufficient subject matter knowledge. In other words, having subject matter knowledge does not guarantee that it will become transformed into representations that will help students comprehend targeted concepts or that teachers will be adept at deciding when it is pedagogically best to use particular representations (p.112).

Furthermore, PCK is subject-specific, topic-specific, teacher-specific, and context-specific (Kind, 2009). Similarly, Magnusson et al. (1999) acknowledged that PCK development is influenced by the nature of the topic, the context in which the topic is taught, and teachers' reflection upon their teaching. Cochran et al. (1991) concluded that "...pedagogical content knowledge is highly specific to the concepts being taught, is much more than just subject matter knowledge alone" (p.10). Likewise, Magnusson et al. (1999) mentioned that each component of PCK shows that there are different types of subject-specific pedagogical knowledge that are utilized in teaching science. For each component, teachers have particular knowledge differentiated by the topic. Teachers should improve their knowledge not only for all of the aspects of pedagogical content knowledge, but also for all of the topics they teach (Magnusson et al., 1999).

Even though both Shulman (1986) and Magnusson et al. (1999) adverted subject-specific and topic-specific pedagogical content knowledge, they did not explain what they explicitly mean and the difference between them. Subsequently, Veal and MaKinster (1999) developed a hierarchical model beginning from general PCK and ending with topic-specific PCK. Topic-specific PCK is the most specific level of their model, which means that a teacher should possess different PCK for various topics. For instance, a science teacher's PCK can be general and involve several content areas (general science), be specific to one discipline (e.g., chemistry, physics), or it can be specific to a topic (e.g., power, chemical equilibrium) Veal and MaKinster (1999).

PCK is also influenced by teachers' own belief systems (Fernandez-Balboa & Stiehl, 1995). Morine-Dersheimer and Kent (1999) also highlighted the role of personal beliefs and perceptions of teaching and learning in developing and shaping

PCK. Similarly, Magnusson et al. (1999) acknowledged that teachers' knowledge and beliefs behave as filters through which they come to comprehend the PCK components. These understandings regulate how each component of PCK is used in classroom teaching. Just like learners' existing knowledge and beliefs function as the initial point for their learning, teachers' knowledge and beliefs are essential resources and circumstances on change (Magnusson et al., 1999).

Park and Oliver (2008a) argued that teacher efficacy, one of the personal beliefs, emerged as an affective affiliate of PCK based on their results of the study. They stated that it is plausible to view teacher efficacy as a component of teachers' knowledge, since it has an important role in identifying problems and deciding teaching strategies to solve the problems. They also underlined that teacher efficacy is a specific rather than a general prospect. This feature is consistent with the domain and topic-specific nature of PCK. Likewise, Gess-Newsome (2015) underlined the role of teacher beliefs which intervenes teacher actions. Therefore, they put teacher beliefs with orientations as an amplifier or filter for classroom practice in TPK&S model.

Additionally, PCK demonstrates a dynamic nature, not static, and so teachers can improve their PCK over time (Kind, 2009; Fernandez-Balboa & Stiehl, 1995). According to Kind (2009), "that teachers' knowledge can develop over time and change in response to different schools/educational settings, students, resources and curricula is a reasonable point for a model to adopt" (p.190). Similarly, Nilsson and Loughran (2011) stated that the improvement of PCK is an evidently complex process decided by the content, the context, and teacher reflection on his/her teaching experiences. Grossman (1990) identified four sources for the development of PCK; namely, apprenticeship of observation, disciplinary background, professional coursework and learning from experience. Apprenticeship of observation contributes to PCK in several ways. For instance, preservice teachers' own experiences about memories of strategies for teaching a particular concept may influence their knowledge of instructional strategies. "Teachers' knowledge of the content becomes confounded with their knowledge of instructional strategies, since what prospective

teachers learned is tied to how they were taught” (Grossman, 1990, p.10). In addition, preservice teachers’ own experiences about their interests and abilities as students in a particular subject may inform their knowledge of student understanding. Similarly, apprenticeship of observation may also contribute to preservice teachers’ knowledge of curriculum, because they are subject to topics, sequences among them at a grade level, and curricular materials. Disciplinary background can contribute to subject matter knowledge as well as knowledge of curriculum. Professional coursework also contributes PCK development (Grossman, 1990). Professional coursework helps learners gain knowledge of teaching specific subject matter (i.e., subject-specific methods) (Grossman, 1990). As being the last, teachers obtained PCK from their actual classroom experience (Grossman, 1990). Teaching experience supplies the opportunity for prospective teachers to check over the knowledge they have obtained from other sources in the classroom (Grossman, 1990). For instance, by working with learners, teachers learn about their difficulties, prerequisite knowledge or misconceptions about a specific topic, and also learn which strategies, representations or activities work well for teaching specific topics (Grossman, 1990). From this point of view, many researchers attributed teaching experience as the primary source of PCK development (Van Driel et al., 2002; Van Driel et al., 2001; Van Driel et al., 1998, Grossman, 1990; Magnusson, et al., 1999). For instance, Cochran et al. (1991) believed that PCK improves in time as a consequence of classroom experience with many learners. They drew two models to represent the difference between the novice and experienced teachers’ PCK (see Figures 2.13 and 2.14).

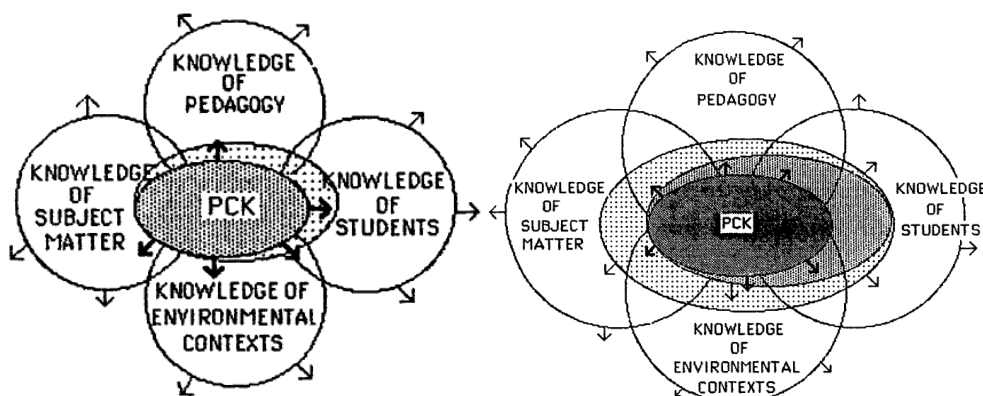

**Figure 2.13** PCK model for the novice teacher **Figure 2.14** PCK model for the experienced teacher (Cochran et al., 1991, p.22-23)

The four components of PCK in these models were exhibited as circles broadening with experience. The growth of PCK was shown with the dark arrows and enlarging core of the model from beginning to experienced teacher. Similarly, Gess-Newsome (1999) argued that teaching experience consolidates the growth, selecting, and use of PCK. On the other hand, several scholars opposed that teaching experience alone may not lead necessarily to robust PCK (Leite et al., 2005; Friedrichsen et al., 2009). It takes long time to be an expert and one may not be successful at the end (Kind, 2009). While this debate has been going on, it should be stressed that, unfortunately, there has been few research of the ways how PCK develops over time.

Finally, science educators agree that PCK is more than the sum of its components. Teachers not only possess all PCK components but also integrate them while planning and carrying out instruction (Abell, 2008). In this respect, the degree of the interaction and harmony among the components as well as the existence of each component indicate the level of a teacher's PCK (Park & Oliver, 2008a; Friedrichsen et al., 2009). The suitable interactions among PCK components may be the most critical element for teaching success (Fernandez-Balboa & Stiehli, 1995). Park and Oliver (2008a) acknowledged that teachers should integrate PCK components and enact them within a given context for an effective teaching. The interplay of the components is carried out by means of the complementary and

ongoing modification via both reflection-in-action and reflection-on-action. This refers that the development of a teacher's PCK through reflection strengthens the consistency among the PCK components (Park & Oliver, 2008a). This strengthening consolidates their interactions, which in order catalyzes the development in PCK and further changes in practice (Park & Oliver, 2008a). However, if a teacher cannot integrate the components coherently into his/her PCK, development within a single component may not be sufficient to develop PCK.

The interactions among different PCK components do not occur as a linear process; instead, multiple choices may appear simultaneously (Fernandez-Balboa & Stiehl, 1995). In order to comprehend the nature of the PCK growth, it is important to understand how PCK components connect and how their connections affect teaching (Park & Chen, 2012). However, little effort has been paid to resolve the complex nature of interactions of PCK components (Park & Chen, 2012). In order to open a fruitful avenue for investigating how PCK components are related to each other, in the next part, research focusing on interplay among PCK components was reviewed.

### **2.3. Research on Interplay among PCK components**

Although given the importance of the conceptualization of PCK, few scholars consider how the components interact during planning and enacting of teaching a specific topic (e.g., Grossman, 1990; Fernandez-Balboa & Stiehl, 1995). Grossman (1990) initially emphasized that there is no clear distinction among PCK components in practice in contrast to in theory. Then, Cochran et al., (1991) viewed PCK as the transformation of four areas of knowledge (knowledge of students, content, pedagogy, and environmental context), and emphasized that these areas should be considered integrated and interrelated. In a similar vein, Fernandez-Balboa and Stiehl (1995) argued that "...it is not the separate existence, but rather the intersection and rightful integration of all these PCK components that comprises good teaching" (p.294). They added that because of integrative nature of PCK, development of any PCK components will also advance PCK as a whole. In addition, the suitable

integration among PCK components might be the most important factor for their successful teaching (Fernandez-Balboa & Stiehl, 1995). Magnusson et al. (1999) also reported that it is essential to understand how the components interact and how their interaction influence teaching. They also added that lack of coherence among the components can be problematic in enhancing and utilizing PCK.

Even though acknowledging that the different components of PCK may interact in highly complex ways, up to now, few researchers have empirically examined the interactions among PCK components and proposed some models that depict the relations among the components. One of the attempts (Henze et al., 2008) focused on PCK development of nine experienced science teachers in terms of relations among knowledge of goals and objectives in the curriculum, learner, assessment, and instructional strategy components over a period of three years. Teachers taught “Models of the Solar System and the universe” topic in a new science subject, Public Understanding of Science (PUSc). The data collection included semi-structured interview held in three subsequent years. As a result of the analysis of interviews, two qualitatively different types of PCK (Type A and Type B) including different types of relations emerged. While Type A was identified as oriented towards model content, Type B was described as oriented towards model content, model production, and thinking about the nature of models. The results revealed that all participants showed a development in their initial PCK over time and the developments of two types of PCK were qualitatively different in terms of interactions among the four components. In type A, the development of teachers’ knowledge about instructional strategies was consistent with their knowledge of goals and objectives in the curriculum and was also related to knowledge of learner. Moreover, teachers’ developing knowledge of learner was associated with their knowledge of assessment. In addition, knowledge of assessment was consistent with their knowledge about instructional strategies. The teachers’ knowledge of instruction methods improved greatly over time; however, their knowledge of assessment did not extend substantially. The authors concluded that some of the components of PCK (particularly knowledge of instructional strategies) developed

much more substantially, but the interplay among them was rather stable. In type B, the development of the teachers' knowledge of instructional strategies was consistent with their knowledge of goal and objectives, and also associated to their knowledge of learner. The growth of knowledge of learner was associated to the teachers' knowledge of instructional strategies and of assessment. In addition, teachers' knowledge of assessment usually improved when their knowledge of learner and instructional strategies developed. Taking into consideration the differences between their knowledge about instructional strategies and student understanding, it may be suggested that teacher-directed pedagogical perspectives for Type A, and more or less student-directed pedagogical perspectives for Type B (Henze et al., 2008). Similarly, Park and Oliver (2008a) concluded that teachers' knowledge of students' misconceptions had an important role in shaping PCK. Particularly, teachers' knowledge of students' misconceptions significantly influenced their knowledge of instructional strategies and assessment.

In a quantitative research, Kaya (2009) examined relationships among PCK components of preservice science teachers within the topic of ozone layer depletion. The PCK includes subject matter knowledge, and pedagogical knowledge consisting of knowledge of curriculum, students' learning difficulties, instructional strategies, and assessment. An open-ended survey was first applied to 216 preservice teachers, and then they were classified as high, average, and low-ability groups based on the level of their subject matter knowledge in the survey. From these three groups, 75 preservice teachers were randomly selected and interviewed to investigate their pedagogical knowledge, the inter-relationships and intra-relationships among PCK components in ozone layer depletion topic. The researcher prepared a scoring rubric and evaluated preservice teachers PCK components as appropriate (3.5 points), plausible (one point), and naive (zero point) based on their responses to the open-ended survey and interview questions. Pearson product-moment correlation coefficient was used to investigate both intra- and inter-relationship among PCK components. Multivariate analysis of variance (MANOVA) was used to examine the effect of the level of preservice teachers' subject matter knowledge on their

pedagogical knowledge and its components. Results showed that there was a significant inter-relationship between preservice teachers' subject matter knowledge and pedagogical knowledge including all of its components ( $r=0.77$ ,  $p<.0001$ ). In other words, preservice teachers with strong subject matter knowledge had more appropriate pedagogical knowledge, while preservice teachers with low subject matter knowledge had more naive pedagogical knowledge. It was also found that the correlation between subject matter knowledge and knowledge of assessment was not as strong as the relationships between subject matter knowledge and knowledge of curriculum, learner, and instructional strategies. Regarding to the intra-relationships among pedagogical components (knowledge of curriculum, instructional strategy, learner, and assessment), there were also significant positive correlations, except for the interactions between knowledge of assessment and other components ( $p>.05$ ). The intra-relationships were generally moderate among the pedagogical knowledge components, except for knowledge of assessment. Kaya (2009) argued that whatever the level of preservice teachers' subject matter was, their ways of assessment were traditional rather than authentic. He claimed that preservice teachers considered that instruction and assessment are distinct elements instead of partners, and they generally use traditional assessment only for grading purpose. According to Kaya (2009), this finding might be caused by preservice teachers' experiences they gained during teacher education programs in Turkey since their conceptual comprehension, specifically in science courses, have usually been assessed by traditional methods. Thus, he recommended additional courses for science teacher education programs which cover all components of pedagogical knowledge.

Similarly, Padilla and Van Driel (2011) analyzed the relationships among PCK components of six university professors who teach quantum chemistry at undergraduate level. First, the interview data were analyzed qualitatively. In order to develop a coding scheme, they used both components of Magnusson's PCK model and some new components developed by the authors by interpreting the content of the fragments of each interview. Then, this coding scheme was used for analyzing all interview data. They assigned codes to each fragment from 1 to 4. After that, they

studied the relative frequencies of each sub-component in the interviews, giving it a value each time it was repeated in particular fragments. The PRINCALS methodology, a quantitative technique, was used to identify the relationships among different sub-components for each professor. Relationships were found between orientations to teaching science and instructional strategies as well as between learner and curriculum components. In addition, regarding the orientation component which was not contained in the study of Kaya (2009), the participants possessed similar orientations (didactic and academic rigor). On the other hand, knowledge of assessment is much less taken into consideration, compared to knowledge of learner, instructional strategies and curriculum, similar to Kaya (2009). They claimed that evaluating the learners' comprehension of quantum chemistry concepts is very difficult and for that reason it needs different assessment strategies instead of traditional examinations.

Recently, a different methodology- the PCK Map approach- has been employed by Park and Chen (2012), in order to explore the nature of the integration of the five PCK components of four biology teachers on the topics of photosynthesis and heredity. They utilized a basic qualitative study design. Data were gathered through non-participant classroom observations, semi-structured interviews, lesson plans, instructional materials, and students' work samples. This study was conceptually and analytically grounded in the pentagon model, which identifies PCK as interplay of the five PCK components (Park & Oliver, 2008a; 2008b). Actually, Magnusson et al. (1999) presented the same five components, but in a linear way. Data were analyzed through three approaches. First, in-depth analysis of explicit PCK was utilized to identify teaching segments which included integrations of two or more PCK components in the pentagon model. A teaching segment, called PCK episode, contained two or more PCK components. The PCK episode reflected teachers' and students' role, which components of PCK were integrated in the PCK episode, and evidence of the presence of the components designated. Then, enumerative approach was used to construct PCK maps, an analytic device, which indicated the connections among the components using the pentagon model. In the

PCK Map, they assumed the same strength of 1 for each link; therefore, the frequency of each link demonstrated the strength of the link. The frequency of the link between any two PCK components was assembled across all PCK episodes and it was represented in the PCK Map. The higher the frequency of the link become, the stronger the link is. Last, with constant-comparative method, considering the interplay of PCK components, they attempted to diagnose common patterns that emerged from the data without using any prior categories or framework. Their analysis of the PCK maps showed five features of the interplays among PCK components. First, the interplays among the components were idiosyncratic and topic-specific. Although the participants taught the same topic with the same instructional materials, their PCK maps showed differences. The participants had more highly structured PCK maps for photosynthesis than heredity. Second, knowledge of learner and instructional strategies components were central in the interplays and were important in shaping the structure of PCK maps. Third, knowledge of curriculum had the most limited relations with other components. Fourth, assessment component was more frequently connected with learner and instructional strategies components than with the other components. This implied that the teachers utilized the assessment with learner and instructional strategies, which are important elements of teaching. Finally, teachers' didactic orientation directed their instructional strategies by preventing its interaction with other components. In addition, theoretical and empirical contributions, this research also made a contribution to methodology by using PCK maps as a tool to identify interactions among PCK components explicitly.

By using Park and Chen's (2012) methodological approach, Aydin and Boz (2013) carried out a research to identify the relationships among PCK components of two experienced chemistry teachers' teaching of electrochemical cells and redox reactions. In this qualitative case study, data were collected through card-sorting activity, CoRe, observation, field notes and semi-structured post-observation interviews. Similar to Park and Chen (2012), their data analysis was based on pentagon PCK model (Park & Oliver, 2008b) and they utilized in-depth analysis of

explicit PCK, enumerative and constant-comparative approaches. Different from Park and Chen (2012), in the enumerative approach, they developed a scoring rubric to grade interplays based on their quality and usefulness for students' learning. While Park and Chen (2012) assumed the same strength of 1 for each link, the authors of this study used a rubric ranging from 1 to 3 for the strength of each link. Findings showed that more interplays were observed in electrochemical cells topic than redox reactions. In addition to patterns (i.e., topic-specific and idiosyncratic nature of PCK, critical role of orientations on instructional decisions) concluded by Park and Chen (2012), new features of the interplays were proposed by the authors of this study. For instance, they concluded that nature of the integrations differed based on their complexity. In other words, some of the interplays were so complicated including more than two components, while others were so simple. Furthermore, integrations had diverse parts such as understanding, decision-making, enactment and reflection. Park and Oliver (2008a) concluded that PCK includes both teachers' understanding of how to teach subject matter knowledge effectively and the enactment of their understanding. However, the findings of this study indicated the steps in the integrations among PCK components (Aydin & Boz, 2013). The first step is to understand a difficulty/misconception/problem. Then, in order to overcome the difficulty/misconception/problem, an instructional decision is taken through the filter of science teaching orientations. After the enactment of the instructional decision, the teacher reflects on the decision and whether it assists students to comprehend and address the problems or not. When these steps were examined, it was easily seen that knowledge of learner and curriculum had a critical role in diagnosing the difficulty or problem that students faced. Science teaching orientations directed their decisions of instructional strategies. In the enactment step, knowledge of instructional strategies and assessment had the main role.

Another attempt to investigate the interaction of all PCK components (Aydin et al., 2015) focused on how interactions among preservice teachers' PCK components enhanced throughout a CoRe-based mentoring-enriched practicum course and the nature of those interactions. In this qualitative research, they observed

three preservice chemistry teachers' teaching of rate of reaction. Data collection sources included CoRes and semi-structured interviews from their previous study. In this study, a secondary analysis was conducted based on researchers' previous study with a new research question. To analyze data, deductive method, content analysis and constant comparative method were utilized. Deductive method was conducted to identify participants' science teaching orientations based on Magnusson et al. (1999) PCK model. Then, they defined categories which reflected two-way interactions among components in pentagon PCK model (Park & Oliver, 2008a). By applying content analysis, they examined the data to identify the interactions among PCK components in participants' teaching segments, similar to Park and Chen's (2012) approach. After that, they drew pre- and post- PCK maps to visualize these interactions and count the frequencies of the interactions in order to understand how the interplay among preservice teachers' PCK component developed through the CoRe-based mentoring-enriched practicum course. Finally, with constant-comparative method, they compared pre- and post PCK maps and reached four common patterns among the interactions of PCK components. First, interactions among PCK components moved from fragmented to a more integrated one at the end of the practicum course. Initially, preservice teachers could not use all PCK components coherently, because the pre-maps indicated missing and more infrequent links among the components than post-maps. They used science teaching orientation, learner and instructional strategies components more frequently than assessment and curriculum components. However, the post-maps showed that the participants were able to use and connect all the components at the end of the course. Second, it was found that the development of interactions was idiosyncratic, particularly in interactions of curriculum and science teaching orientations with the other components, which was a significant contribution to the PCK literature. They discussed that the idiosyncratic nature of development among the components might stem from the person-specific nature of PCK. Third, the most remarkable development was observed between curriculum and other components, which may stem from the explicit consideration of curriculum during the course enriched with

CoRes and educative mentoring. Finally assessment component was not connected with instructional strategies in any map. This might be due to the limited reflection opportunities, and their didactic orientation inhibiting the interaction between assessment and instructional strategy components (Aydin et al., 2015).

Different from the previous studies, Demirdöğen (2016) explores the complexities of how preservice teachers' science teaching orientations interplay with other PCK components utilizing Friedrichsen et al.'s (2011) orientation model and Magnusson et al.'s (1999) PCK model. In this qualitative study, the data were collected from 8 preservice science teachers through CoRes, responses to an open-ended instrument, and semi-structured interviews. Deductive analysis was used to analyze participants' orientation and other PCK components. Then, constant-comparative method was used to analyze the interactions between orientation and other PCK components. The data analysis yielded 3 major themes. First, a teacher's purpose for science teaching determined the interplay between PCK components. For instance, only content-related purposes had interactions with all other PCK components, while purposes of everyday coping and scientific skill development had the interactions with curriculum, instructional strategies and assessment components. Second, preservice teachers' beliefs about nature of science (NOS) did not directly interact with their PCK, unless those beliefs were linked directly with the purposes of teaching science. They did not undertake to teach NOS unless their beliefs about the NOS were connected with their purposes. Third, beliefs about science teaching and learning had the most interactions with knowledge of instructional strategies. The findings of this study have valuable implications in terms of discovering how the gap between orientation and other PCK components can be filled in.

It seems that science teacher educators have reached the consensus that for an effective teaching and a well-developed PCK, teachers should have all the PCK components integrated together. These previous studies opened a fruitful door to the understanding of how PCK components interact with each other. Still, it reveals the need for research on the designation of the components the teachers commonly lack or have, and the difficulty of connecting with other components for specific topics

(Park & Chen, 2012). Additionally, there is much to be learned about how PCK is structured for teaching different topics within the same discipline (Abell, 2008), and how PCK and the interactions among the components are different for beginning versus experienced teachers (Park & Chen, 2012). In this respect, this present study fills in the gaps in the literature.

#### **2.4. Research on how teaching experience is related to PCK development**

While science educators accepted that PCK is an important knowledge domain for science teachers, they have not reached a consensus on how it grows. One of the most controversial issues among science teachers has been the role of teaching experience in the development of PCK. Many researchers considered teaching experience as the primary source of PCK development (Van Driel et al., 2002; Van Driel et al., 1998, Grossman, 1990; Magnusson, et al., 1999; Van Driel et al., 2001). For instance, Nilsson (2008) emphasized that “Student-teachers’ lack of classroom teaching experience must inevitably influence what their PCK might look like compared with that of experienced science teachers” (p.1284). On the other hand, the other researchers emphasized that teaching experience alone does not lead necessarily to robust PCK (Leite, et al., 2005; Friedrichsen et al., 2009, Kind, 2009). To illustrate, Kind (2009) argued that the process of transition to expert takes a long time and one may not be successful at the end.

Relatively few investigations have compared and contrasted PCK among teachers with teaching experience and those lacking teaching experience to bring out the role of teaching experience in the development of PCK. Some studies concluded that there were differences between individuals with teaching experience and those lacking teaching experience. One such studies was conducted by Clermont et al. (1994), who compared novice and experienced chemistry teachers’ PCK in conducting chemical demonstrations as an instructional strategy for teaching density and air pressure. The participants of this study were seven novice teachers with minimal experience in conducting chemical demonstrations and five experienced teachers with much more experience in conducting chemical demonstrations in

classrooms. The collection of data involved clinical interviews and videotape materials to probe PCK of teachers. Qualitative and quantitative comparisons between two groups put forward that the experienced teachers had a greater repertoire of chemical demonstrations for teaching density and air pressure than the novice teachers. In addition, the experienced teachers paid much more attention to the variations in the chemical demonstrations they observed and explained them in a more detailed way than did the novice teachers. The experienced teachers realized much more the students' difficulties and the sources of these difficulties, and knew the ways of addressing them than the novice teachers. The experienced teachers, in contrast to the novices, were more familiar with the complexity of chemical demonstrations, equipment and setup, how these complexities might inhibit learning, and how simplified variations of chemical demonstrations could improve learning of concepts. The experienced teachers supplied much more information about the alternative demonstrations they discussed for each concept than the novice teachers. As a conclusion, the findings of this study indicated that the experienced teachers' PCK of how to demonstrate chemistry concepts were much broader than that of novices.

Another comparative research was conducted by Veal and Kubasko (2003). They explored geology and biology teachers' PCK of evolution which is a common topic in both domains of science. In this case study design, they tried to comprehend how and why 12 secondary preservice and in-service teachers' from the biological and geological science disciplines differ in teaching evolution. They collected the data through classroom observations, semi-structured interviews, field notes, and unstructured conversations with teachers. Content analyses revealed that both preservice biology and geology teachers taught evolution very didactically because of their lack of knowledge of learners' background and topic-specific activities, labs, and analogies. For instance, the preservice geology teachers used few analogies or activities than experienced teachers. On the other hand, the experienced teachers, especially the biology teachers created a more discussion environment to make

interpretations of evolution with their students than did the preservice teachers. This might be attributed to teaching experience and PCK.

In a similar study, Mohlouoa, Rollnick, and Oyoo (2013) explored the role of experience in the improvement of PCK by comparing two physics teachers' PCK with different levels of teaching experience. Two teachers, with 19 and three years of teaching experiences, taught the same topic, radioactivity. In this qualitative case study design, CoRe, semi-structured interviews, and classroom observations were used to portray the teachers' PCK for teaching radioactivity. Analysis of data indicated that both teachers possessed some similar views about teaching radioactivity; but their ways of teaching this topic showed differences. According to CoRe analysis, the content each teacher aimed to teach, difficulties related to teaching this topic and some instructional strategies the teachers used showed differences. Specifically, the experienced teacher had much more knowledge about student difficulties in this topic than the beginning teacher, which is similar to the findings of Clermont et al. (1994). This result could be attributed to his level of teaching experience because he confronted with some of these difficulties in the previous years of his teaching profession.

Different from the previous studies, some researchers examined preservice and beginning science teachers' PCK and its development in their early career for teaching profession. In a study conducted by Lee et al. (2007), beginning teachers' PCK and its enhancement during the first year in the classroom was investigated. Participants of this study were 24 secondary science beginning teachers who were enrolled in four different induction groups: *e-mentoring* (beginning teachers were offered online mentoring with each other and experienced teachers); *general* (beginning teachers worked with experienced teachers in a traditional mentoring program); *intern* (teachers did not have any certification or preservice teacher education, but they were monitored by their mentors in the certification process); and *science specific* (teachers concentrated on science-specific professional development, consisting of in-field mentor assignments). Pre- and post-interviews were conducted and participants' teaching practice was observed four times. In order to assess

beginning teachers' PCK, the researchers improved a rubric focused only on two PCK components: knowledge of learner and knowledge of instructional strategies. Then, they analyzed the interviews and observations data by using this PCK rubric which included three levels of proficiency: limited, basic, and proficient. Then, they conducted Kruskal-Wallis test to analyze the variations in PCK among four induction groups of beginning teachers. Finally, Wilcoxon signed-ranks test was applied to find the change of the teachers' particular PCK components using the pre- and post-test data. Results showed that 24 beginning teachers possessed limited or basic PCK levels. Descriptive analysis of pre-test data indicated that 76% of teachers were in the limited level and 24% of them were in the basic level; while descriptive analysis of post-test data showed that 65% of them were in the limited level, 34% of them were in the basic level, and 1% of them in the proficient level. Moreover, Kruskal-Wallis test revealed that there was no statistically significant difference in PCK levels of various induction groups ( $H(4, N=24) = 2.89, p=.44$ ). The Wilcoxon signed-ranks test showed that knowledge of learner with three subcategories (prior knowledge, variations in students' approaches to learning, and students' difficulties with specific science concepts) had a statistically significant change. On the other hand, the change in knowledge of instructional strategies with two subcategories (scientific inquiry and representations) was not statistically significant. They concluded that the beginning science teachers possessed a limited PCK level in spite of their science backgrounds. In other words, a robust science background does not ensure an adequate level of PCK. For instance, beginning teachers with advanced science degrees, had lack of knowledge about adjusting activities and materials according to the students' needs and observing students' learning. Lee et al. (2007) thought that PCK develops over time through teaching experience. Therefore, they suggested that coursework in preservice programs should include science methods courses or courses focusing on classroom experience instead of just content coursework.

Brown, Friedrichsen, and Abell (2013) examined how four prospective secondary biology teachers' science teaching orientations, knowledge of instructional sequence and knowledge of learner, improved throughout a post-baccalaureate

science teacher preparation program (STEP). In this program, all participants enrolled in a concentrated, 8-week summer block of introductory education courses, and also they were teaching interns at partner high schools (20 h per week), and attended extra campus-based coursework, consisting of three Secondary Science Methods courses. This study was a longitudinal, multiple case study and the data was collected during the first three semesters of this program. First, by using lesson-planning task for documenting incoming PCK, participants designed two 50-min lessons to teach 8<sup>th</sup> graders. Then, follow-up semi-structured interviews were carried out with all prospective teachers. A second-interview, at the end of the first summer of the program, was conducted to let the participants make revision, reflection on, and modification of their first lesson plan taking into consideration what they have learned in their summer coursework. Then, for each of the fall and spring semesters, they conducted two interview-observation cycles (pre-observation interviews, two sequence days of field observations, and two stimulated-recall interviews) along with the teachers' internships in local schools to document their PCK development. After coding the data by using qualitative data analysis software, NVivo 7 based on Magnusson et al.'s some PCK components, they conducted a cross-case analysis of all participants to see the emerging patterns and themes. They found that the participants' strongly held orientations to science teaching were based on their experiences as students and other background experiences. Their existing orientations were solid and resistant to change throughout the yearlong teacher preparation program. Moreover, the results showed that as the teachers gained teaching experience, they improved a growing awareness of learners' difficulties, and broadened their knowledge of the requirements of learning, which was also concluded by Lee et al. (2007). In addition, all four teachers' knowledge of instructional strategies increased during the fall and spring semesters. Although the teachers improved additional instructional strategies, all of them continued to believe that teaching and learning occur when the teacher transmit new terms and concepts to learners through 'inform' types of instruction. For instance, they learned and designed 5E instructional sequence in science method courses, but they were unable

to implement the 5E model in their internship classrooms. Furthermore, the teachers' growing knowledge of students' understanding and instructional strategies nearly aligned with their orientations. They observed that the teachers' science teaching orientations directly influenced the interaction between knowledge of instructional strategies and learners. They concluded that when preservice teachers obtained more experience and knowledge, the interplay between knowledge of learner and instructional strategies developed. Similarly, Van Driel et al. (2002) conducted a qualitative study to investigate the role of teaching experience in the PCK growth. They worked with 12 preservice chemistry teachers. The data were collected through two written questionnaire, interviews, and an audio recording of a workshop session in the teacher education program. They concluded that the growth of PCK was affected mostly by the teaching experience of preservice teachers, which is similar to the findings of Brown et al. (2013).

The study conducted by Lee and Luft (2008) was different from the other studies, since they examined PCK from the perspective of teacher. With a case-study design, they looked at how science teachers conceptualized their own PCK. Specifically, they tried to depict PCK of four experienced secondary science teachers. The data were gathered over 24-month period, consisting of semi-structured interviews, classroom observations, lesson plans and monthly reflective summaries. The aim of the first interview was to collect biographical information. The second interview was conducted after teaching with the aim of clarification of the observed teaching, and understanding the teachers' perceptions about the knowledge for teaching science. In the last interview, teachers constructed a diagram showing PCK components and elements through card sort tasks and concept mapping. In the interview, the relationships among the components of PCK were asked to the teachers. After coding the data with open, axial and selective coding procedures, constant-comparative analysis was conducted. The teachers designated seven components of PCK as fundamental areas in science teaching; namely, knowledge of science, knowledge of goals, knowledge of students, knowledge of curriculum organization, knowledge of teaching, knowledge of assessment, and knowledge of

resources. The teachers also articulated that these components were interwoven and influenced each other in different ways. For all participants, knowledge of science, a strong science background, was the primary knowledge base for teaching science. The teachers also emphasized that these knowledge types were improved over years of teaching experience and with participation in workshops. Moreover, this research proposed that knowledge of resources should be examined to decide whether it may be another component of PCK, because all teachers' knowledge of resources influenced their curriculum organization, selection of teaching strategies, and use of assessments.

On the other hand, some studies concluded that there were only few differences between individuals with teaching experience and those lacking teaching experience. For example, Friedrichsen et al. (2009) compared individuals with teaching experience to those lacking teaching experience in Alternative Certification Program (ACP). In order to compare the prior knowledge between the groups (interns and full-time teachers), two interns with no teaching experience and two full-time teachers with 2 years of high school biology teaching experience were selected. As a data collection tool, they utilized Lesson Preparation Method in which the participants prepared their lesson plans to teach the heritable variation concept. This tool also enabled the researchers to elicit the participants' PCK. After conducting this method, the participants were interviewed about their lesson plan to elicit the details of plan in terms of what the teacher and the students did in each part of the lesson, their PCK components and sources of their PCK. By applying NVivo qualitative research software, they first coded the lesson plans and interview data according to the Magnusson et al. (1999) PCK components. Then, they coded the data to distinguish cases of discipline-specific PCK from topic-specific PCK based on Veal and MaKinster's (1999) PCK taxonomy and the work of Davis and Krajcik (2005). The authors put forward two assertions. The first assertion was that while designing their lesson plans, both teachers and interns used general pedagogical knowledge, rather than topic-specific PCK for teaching heritable variation. To illustrate, all participants held didactic orientations and viewed teaching as transmitting

knowledge to the learners. The participants lacked knowledge of learner. Although teachers and interns foresaw that students might have some prior knowledge about genetic variations, they could not make use of this knowledge while teaching. In addition, the interns thought that the students would not have any difficulty with their lessons, whereas the teachers, based on their teaching experience, stated that the students might have some difficulties with the lessons. However, the teachers designated more general students' difficulties (e.g., abstractness or terminology), rather than topic-specific students' difficulties within genetics concepts. None of the participants was knowledgeable about students' common misconceptions within the topic. Moreover, both groups had limited knowledge of instructional strategies, and relied primarily on their general pedagogical knowledge. Both groups designed their plans with the same teaching sequence including a short questioning period, lecture and guided practice. The researcher found only two examples of topic-specific instructional strategies (e.g., use of Punnett squares). Pertaining to curriculum knowledge, the interns viewed curriculum as a textbook whereas the teachers had a broader view of curriculum involving the state and distinct curriculum guidelines. Neither teachers nor interns included assessment in their written lesson plans. Therefore, in the interviews, the participants were asked how they assessed their students' understanding. While the teachers planned to assess their students informally during the instruction, the interns planned to use summative assessment after the instruction. They used assessment to decide whether they needed to repeat their lessons. None of the participants identified topic-specific assessment strategies. The second assertion was that the teachers could connect some pedagogical knowledge components each other, which the interns could not. The interactions among the teachers' pedagogical knowledge components were limited, because their lack of knowledge of assessment and learners' difficulties components did not inform their alternative instructional strategies. The interns used primarily their subject matter knowledge, because of their limited pedagogical knowledge. The results of this study indicated that there were few differences between individuals with teaching experience and those lacking teaching experience. In addition, all

participants lacked topic-specific knowledge about curriculum, learner, assessment and instructional strategies.

Another study identifying the effects of teaching experience with a comparative study was implemented by Leite et al. (2005). The aim of this study was to compare preservice and in-service teachers' explanations for liquid-state phenomena in three European countries. The authors of the study compare the participants' subject matter knowledge as a component of PCK in order to draw a conclusion whether PCK develops from experience. The participants of the study were 195 Italian, Portuguese, and Spanish science teachers. They were 80 in-service science teachers (with at least 2 years of teaching experience) and 115 preservice science teachers. The authors prepared a questionnaire including seven questions about liquids or liquid-state phenomena. Data analysis was conducted question by question in order to make comparisons between pre- and in-service teachers' answers given to each question. Chi-square test was used to analyze the data. The statistical analysis of data indicated that the participants showed poor performance with low percentages of correct answers. Their performance appeared independent of nationality. Both pre- and in-service teachers had difficulties in explaining submicroscopic predictions. In addition, pre- and in-service teachers in each of the 3 countries showed a similar performance for some questions (e.g., questions 3 and 4). For question 5, Portuguese and Italian preservice teachers showed a better performance than in-service teachers, in contrast to what was expected. Therefore, they offered that preservice teacher education and continuing teacher education courses should concentrate on developing teachers' PCK.

Another study was conducted to compare and contrast experienced chemistry teachers' topic-specific PCK in teaching two different chemistry topics (Aydin, Friedrichsen, Boz, & Hanuscin, 2014). By using a case study methodology, they collected data from two experienced chemistry teachers through CoRe, card-sorting activity, semi-structured interviews, observations and field notes for teaching electrochemical cells and nuclear reactions. This study was based mainly on Magnusson et al.'s (1999) PCK model with some alterations. Deductive and

inductive analyses were used for data analysis. The results showed that both teachers utilized more 'content-based and teacher-centered instruction for teaching electrochemical cells, while they used less 'teacher-centered instruction including NOS and Science-Technology-Society-Environment' for teaching nuclear reactions. The teachers did not perform any discipline-specific strategies (e.g., inquiry); however, they used several topic-specific strategies (e.g., demonstrations) for teaching both topics. The teachers' curriculum knowledge varied and they had much more curriculum knowledge in electrochemical topic than nuclear reactions topic. Likewise, they showed differences in the extent of their knowledge of learners, and they possessed more knowledge of learners in electrochemical cells topic than nuclear reactions topic. On the other hand, both teachers had mainly didactic orientations, and these orientations did not change according to the different topics. None of the participants used topic-specific assessment strategies. The authors stated that teaching experience alone was not enough to broaden teachers' topic-specific PCK. Therefore, they supported that professional development should consist of not only discipline-specific activities but also topic-specific activities within that discipline. Additionally, both preservice teacher education and induction year mentoring programs should concentrate on how preservice and beginning teachers improve their topic-specific PCK as well as discipline-specific PCK.

Luft (2009) studied the first year of 114 secondary science teachers while they were participating in one of four different induction programs. These were: general induction, science-specific e-mentoring, science-specific induction, and alternative certification programs. In this mixed-method design, as a data collection procedure, the teachers were first interviewed about their background information, beliefs about teaching science and PCK prior to the start of the school year. Then, they were observed and interviewed eight times after the instruction throughout the school year. At the end of the school year, post-interviews were conducted about the teachers' school year, their beliefs about teaching science and PCK. Concerning PCK, they focused on only two components: knowledge of instructional strategies and knowledge of learners. In terms of qualitative data, the codes (1= limited, 2= basic,

3= proficient) were used. Regarding quantitative data, parts of the text from the interviews were put in groups related to the topics in the literature review (e.g., representations of science, instructional strategies), and the topics about the quantitative codes (e.g., mentors, value of the induction program). Findings revealed that the overall PCK of beginning teachers did not change significantly over the year ( $F(1,3) = 0.08$ ,  $p = .24$ ). Their PCK was scored as limited, which was described by relying on a few instructional strategies, not identifying the students' prior knowledge, not accommodating various learners, rarely utilizing representations for subject matter, and struggling to think the use of inquiry in their teaching. However, when knowledge of learner and instructional strategies components were analyzed as subsets, a significant difference was found in the learner component ( $F(1,113) = 0.06$ ,  $p = .01$ ). This finding could be linked to the beginning teachers teaching with students in their classrooms, being more aware of their students' learning, and accommodating their teaching properly. Moreover, at the end of the year, there were no significant differences in PCK among induction programs. A similar study conducted by Luft et al. (2011), in which they explored the changes in beginning secondary science teachers' beliefs, PCK, and practices as a group during their first and second year of teaching in different induction programs. 98 teachers participated in one of four induction programs that were described in Luft (2009). After analyzing the qualitative and quantitative data, they concluded that overall PCK of beginning teachers changed significantly over the two years ( $F(2, 188) = 24.1$ ,  $p = 0.00$ ), but not by induction programs ( $F(3,91) = 0.33$ ,  $p = 0.92$ ). The beginning teachers' PCK was cultivated and developed over the course of their first two years in the classroom, because they worked with students.

## **2.5. Summary of the Literature Review**

The nature of interactions among all PCK components (science teaching orientations, knowledge of learner, knowledge of instructional strategies, knowledge of curriculum, and knowledge of assessment) of novice and experienced chemistry teachers is investigated in this study. In addition, the role of teaching experience on

the interactions among PCK components was examined. Therefore, related literature was reviewed under the headings of conceptualization of PCK, nature and characteristics of PCK, research on interplay among PCK components, and finally research on how teaching experience is related to PCK development.

Literature indicates that Shulman's work on PCK has inspired a large number of educational scholars (e.g., Park & Oliver, 2008a; Hashweh, 2005; Grossman, 1990). Some of these scholars have tried to modify Shulman's definition, and identify different components with different PCK models (e.g., Grossman, 1990; Magnusson et al., 1999), while others conceptualize PCK as an integration of those components (e.g., Park & Oliver, 2008a). Regarding nature and characteristics of PCK, the literature revealed that PCK is a transformation rather than a blend of knowledge, including subject matter knowledge, pedagogical knowledge and knowledge of context (Grossman, 1990 & Gess-Newsome, 1999). In addition to this, adequate subject matter knowledge is a prerequisite for PCK development (Van Driel et al., 1998; Abell, 2007). Moreover, PCK demonstrates a dynamic nature, and teachers develop PCK over time as they learn from teacher preparation programs, classroom observations both as a student and during preservice teacher education, professional development opportunities and teaching experience (Grossman, 1990; Van Driel et al., 1998; Abell, 2008). From this point of view, many researchers have attributed teaching experience as the primary source of PCK development (Van Driel et al., 2002; Van Driel et al., 2001; Van Driel et al., 1998, Grossman, 1990; Magnusson, et al., 1999). However, teaching experience alone may not lead necessarily to robust PCK (Leite et al., 2005; Friedrichsen et al., 2009). Furthermore, PCK is topic, person, and situation specific and teachers' PCK largely influences their decisions in classroom settings (Kind, 2009). PCK is also affected by teachers' own belief systems (Fernandez-Balboa & Stiehl, 1995; Morine-Dersheimer & Kent, 1999). Finally, science educators agree that PCK is more than the sum of its components (Abell, 2008; Park & Oliver, 2008a). Teachers should have all PCK components and integrate them while planning and enacting their instructions (Abell, 2008). The coherent relationships among them are important for PCK development

and these relationships are highly complex in nature (Park & Oliver, 2008a). However, until now, few studies have been carried out to explore the interconnectedness among all PCK components (Henze et al., 2008; Padilla & Van Driel, 2011; Park & Chen, 2012, Aydin et al., 2015). The literature indicates that how PCK components interact with each other for different topics or how these interactions develop when teachers gain more experience have not been fully resolved (Park & Chen, 2012). Therefore, the nature, dynamics, qualities and complexities of the connections of all PCK components in different topics, how these connections influence teaching practice, and how teachers' different levels of teaching experiences influence these connections need further investigation. Taking these gaps in the literature into consideration, I aim to investigate the nature of interactions among PCK components of novice and experienced chemistry teachers' teaching of two different chemistry topics within the same grade level as well as the role of teaching experience on the interactions among PCK components.

## **2.6. PCK Framework of the Present Study**

The theoretical construct of PCK framed this study. Specifically, Magnusson et al.'s (1999) PCK model and Park and Oliver's (2008b) pentagon model of PCK served as both the conceptual and analytic framework. Magnusson et al., (1999) proposed their PCK model in a specific discipline, which is '*science*.' They conceptualized PCK for science teaching as a mixture of five types of knowledge: orientations towards science teaching, knowledge of curriculum, knowledge of learner, knowledge of assessment, and knowledge of instructional strategies. Magnusson et al. (1999) emphasized that these components may interact in highly complex ways; therefore, it is important to understand how they interact and how their interactions affect teachers' teaching. Nonetheless, in their PCK model, the five components are drawn in a linear way, and the only explicit link in this model is between science teaching orientation and each of the other four components. In contrast to Magnusson et al.'s linear model, Park and Oliver (2008b) represented the same five components in a pentagonal form to represent the integration of the

components. As a conclusion, the pentagon model of PCK which was grounded in the work of Magnusson et al. (1999), serve as a heuristic devise for organizing the present study.





## CHAPTER 3

### METHODOLOGY

This study mainly focuses on the nature of interaction among PCK components of novice and experienced chemistry teachers in the teaching reaction rate and chemical equilibrium. Moreover, I examined the role of teaching experience, if any, on the interactions among PCK components regarding teaching these two topics.

In this chapter, I will present detailed information about the method of inquiry. Within this perspective, in this chapter, I will discuss research design and the rationale for the research design. Then, I will explain participants, procedure, context, data collection methods, and data analysis procedure. Finally, I will deal with the issues of validity and reliability, ethical considerations, researcher's background and role, and assumptions of the study.

#### 3.1. Research Questions

In this study, the nature of interactions among all PCK components of novice and experienced chemistry teachers were investigated through the following research questions:

1. What is the nature of interactions among PCK components of novice and experienced chemistry teachers in teaching reaction rate and chemical equilibrium topics?
2. What is the role of teaching experience, if any, on the interactions among PCK components in teaching reaction rate and chemical equilibrium topics?

#### 3.2. Design of the Study

This research is qualitative-interpretive in nature (Merriam, 2009). The main aim of this study is to explore the nature of interactions among PCK components of

novice and experienced chemistry teachers to teach two chemistry topics. Qualitative methodology fits better for my research problem because of several reasons. First of all, qualitative research is conducted because a problem or issue needs to be explored (Creswell, 2007). Regarding my study, based on the existing literature, there is a need to examine topic-specificity of PCK in different topics within the same discipline (Abell, 2008), novice teachers' topic-specific PCK (Luft et al., 2011), the comparison between novice and experienced science teachers' PCK (Clermont et al., 1994), and the relationships among PCK components (Friedrichsen et al., 2011). Another reason of conducting qualitative research is the need of complex and detailed understanding of the issue (Creswell, 2007). In this study, by conducting qualitative research, I tried to delve into the nature, dynamics, and complexities of interplays among PCK components related to teaching reaction rate and chemical equilibrium topics in chemistry. Moreover, qualitative research is carried out to comprehend the contexts or settings in which participants in a research address a problem or issue (Creswell, 2007). Accordingly, because of context-specific nature of PCK, I conducted qualitative research to understand the context or setting in which the novice and experienced teachers address the issue of this study. Another reason why qualitative methodology was used in this study is that quantitative measures and statistical analyses simply do not address the problem. Due to person-specific nature of PCK, I wanted to compare the novice and experienced teachers' teaching to bring out the differences in terms of PCK as well as interactions among PCK components. In addition, I was interested in process, i.e., how the things occur, as well as product (Creswell, 2007). I aimed to observe how teachers interact with students, how teachers answer students' questions, the meanings that the teachers give to certain words and actions, gestures or comments during the instruction.

According to Merriam (2009), "qualitative researchers are interested in understanding the meaning people have constructed, that is, how people make sense of their world and the experiences they have in the world" (p.13). Different qualitative researchers have identified different characteristics, even though there is absolutely some overlap. For instance, Creswell (2009) widely presented several

characteristics of qualitative research to understand the nature of qualitative research.

I explained how I adapted them into my study below:

1. Natural setting: In this qualitative study, I collected the data in the field where the participants experience the issue or problem under the study instead of bringing them in to contrived situation. During data collection process, the participants taught the reaction rate and chemical equilibrium topics in their real classes.
2. Researcher as a key instrument: I gathered the data myself via investigating documents, observing behavior, and interviewing the participants.
3. Multiple sources of data: As a researcher, I collected multiple forms of data involving observations of instruction, pre-interview in the form of content representation (CoRe), post-interviews, card-sorting task, and documents such as instructional materials instead of relying on a single data source. Then, I reviewed all the data in order to organize them into categories and themes.
4. Inductive data analysis: The interactions among PCK components were analyzed inductively.
5. Participants' meanings: During this qualitative research process, I focused on learning the meaning that the participants held about the PCK components and the interactions among them.
6. Theoretical lens: In this study, PCK framework was used as the theoretical lens to compare and contrast the participants' teaching of reaction rate and chemical equilibrium topics.
7. Emergent design: The design of a qualitative study is emergent and flexible. The initial plan may change. For instance, at the beginning of the present study, the teachers were supposed to fill the CoRe themselves. However, they were reluctant. Then, I changed my plan and I decided to ask CoRe questions during the interviews.
8. Interpretive: As a qualitative researcher, I always tried to interpret what I see, hear, and understand in the context of the study.

9. Holistic account: In this study, I tried to identify the complex picture of the nature of interactions among PCK components of the teachers with different levels of teaching experience within the context of teaching reaction rate and chemical equilibrium topics.

Qualitative researchers have suggested a variety of qualitative research strategies. For instance, Merriam (2009) mentioned seven commonly used strategies: basic qualitative research, phenomenology, ethnography, narrative analysis, critical qualitative research, and case study. They fall under the umbrella concept of “qualitative”; however, they are different from each other in terms of their focus, research question, sample selection, data collection and analysis, and write-up. Similarly, Creswell (2007) recommended five approaches to qualitative inquiry which are popular in social and health science today: narrative, phenomenology, ethnography, case study, and grounded theory. Regarding these five approaches, researchers can study individuals with narrative and phenomenology; find out processes, activities, and events through case study and ground theory; or examine a cultural group in a natural setting (ethnography).

Among these approaches, case study guided this study in designing, collecting, and analyzing the data. A case study refers to an in-depth description and analysis of a bounded system (Merriam, 2009). Yin (2009) described the case study as “... an empirical inquiry that investigates a contemporary phenomenon in depth and within its real-life context, especially when the boundaries between phenomenon and context are not clearly evident” (p.18). One might prefer to use case study as s/he wanted to comprehend a real-life phenomenon in depth, but such comprehension involved substantial contextual conditions-because they were highly related to her/his phenomenon of the study. Case study includes the research of an issue investigated by focusing on one or more cases within a bounded system such as a setting or a context through detailed, in-depth data collection with multiple sources of information (e.g., interviews, observations, reports, documents, and audiovisual material) (Creswell, 2007). A “case” can be an individual, an event, or entity. Moreover, case studies may be conducted about decisions, programs, the

implementation process, and organizational change (Yin, 2009). Accordingly, in this research, the issue (the nature of interactions among PCK components) was explored through multiple cases (novice and experienced chemistry teachers' teaching) within a bounded system (the context of teaching reaction rate and chemical equilibrium topics) via in-depth data collection sources (e.g., observations, interviews, etc.). Moreover, a case study investigates "how" and "why" questions which examine contemporary set of events, but when the investigator has little or no control (Yin, 2009). The present study concentrated on contemporary set of events (novice and experienced chemistry teachers' teaching), and examined how the nature of interactions among PCK components of these teachers and to what extent teaching experience is related to the interactions among PCK components in teaching of reaction rate and chemical equilibrium topics. Furthermore, the purpose of a case study is to broaden and generalize theories and not to do the statistical generalization (Yin, 2009). Accordingly, the purpose of this study is to broaden the theory of PCK especially in terms of interactions among PCK components within a specific discipline. In a case study, the researcher is interested in insight, discovery, and interpretation rather than testing hypothesis (Merriam, 2009). Additionally, Merriam (2009) characterized case study as being particularistic, descriptive, and heuristic. Particularistic signifies that a case study concentrates on a specific situation, event, program or phenomenon. Descriptive signifies rich and thick description of the phenomenon under the study. Heuristic refers to a case study which enlightens the reader's comprehension of the phenomenon under study. In the present case study, the researcher focuses specifically on the interactions among PCK components of novice and experienced chemistry teachers' teaching reaction rate and chemical equilibrium topics and tried to illuminate the readers' understanding about the phenomenon by providing thick description about it.

Creswell (2007) categorized case studies into three in terms of the intent of the case analysis: the single instrumental case study, the intrinsic case study, and the collective or multiple case study. In a single instrumental case study, the inquirer concentrates on an issue or concern, and then chooses one bounded case to illustrate

this issue. The intrinsic case study concentrates on the case itself (e.g., evaluating a program, or studying a student having difficulty, etc.) since the case represents an uncommon or single situation. Finally, in a collective case study or a multiple case study, the inquirer again focuses on an issue or concern; however, s/he chooses multiple case studies to illustrate different perspectives on the issue. For instance, a researcher may select a number of programs from a number of research sites or multiple programs within a single site for a study. According to Yin (2009), the logic underlying the use of multiple-case studies is either *a literal replication* which refers to prediction of similar results, or *a theoretical replication* which refers to prediction of contrasting results but for anticipatable reasons. The present study comprises a multiple case study in which multiple cases (novice and experienced teachers' teaching) were compared and contrasted to illustrate different views on the issue (the nature of interactions among PCK components).

### **3.3. Participants**

Participants in this study were chosen through a process of purposeful sampling (Creswell, 2007). Purposeful sampling is the method of choice for most qualitative research (Merriam, 2009). Purposeful sampling strategy means that the researcher chooses individuals or sites for research since they can purposefully inform a comprehension of the research problem and phenomenon in the study (Creswell, 2007). In this sampling method, the researcher wants to discover, comprehend, and gain insight about a sample. Therefore, s/he selects a sample that will help the collection of the richest data (Merriam, 2009). According to Paton (2002), the logic and power of purposeful sampling derive from the emphasis on in-depth understanding, and this requires selecting information-rich cases for study. "Information-rich cases are those from which one can learn a great deal about issues of central importance to the purpose of the research, thus the term purposeful sampling" (Patton, 2002, p.46). According to Creswell (2007) and Merriam (2009), researchers should first decide the criteria for selecting the individuals or sites to start purposive sampling. The criteria reflect the aim of the research and lead the

identification of information-rich cases (Merriam, 2009). In the present study, three cases were identified through a process of purposeful sampling based on certain criteria in order to achieve a full understanding of the phenomenon as much as possible. The first criterion was related to the context of the study. PCK has a context-specific nature and is influenced by the context in which the teachers work (Van Driel et al., 1998). Therefore, I selected teachers from the same context. All teachers were working in the same private school in Ankara at the time of the study; therefore, they had similar instructional materials and equipment in their classrooms. The second criterion was that teachers had different levels of teaching experience. In order to investigate the interactions among PCK components of chemistry teachers with different levels of teaching experience, I chose three teachers who were suited to the objective of the study. They were chemistry teachers with different levels of teaching experience. Betül was a novice teacher with a three-year teaching experience at the period of the present study and she taught both reaction rate and chemical equilibrium topics for the first time in a classroom environment. Simge and Burak, who had 12 and 20 years of teaching experience respectively at the time of the study, and they had been teaching both topics for many years. Both Simge and Burak had worked for different private schools before being employed in the current private school. Betül had worked in a private teaching institution for 1 year. Then, she started to work at the current private school. Apart from this, all teachers graduated from the same chemistry education program in the same university. Therefore, they had a similar background in terms of coursework consisting of chemistry, pedagogical, and subject-specific pedagogical courses. Only Simge had a master degree in science education. They voluntarily accepted to be involved in this study. Pseudonyms are used for confidentiality. The third criterion was subject matter of teachers. Because of the researcher's major area in chemistry education, teachers who have a major in chemistry were selected. This provided the researcher with a convenient examination of the teachers' PCK in specific chemistry topics, reaction rate and chemical equilibrium. This was an important issue because examining PCK components in a specific topic required topic specific knowledge. The fourth

criterion was to select easily accessible participants in order to carry out deep investigation and also find teachers who have the highest potential of obtaining deep information on PCK in a specific topic. Moreover, the appropriate schedules of the teachers without any overlap help me select these teachers from the same school.

The size of the sample is also a significant decision to sampling strategy in data collection process (Creswell, 2007). One general principle in qualitative research consists of both studying a few sites or individuals and gathering comprehensive detail about each site or individual studies. The aim of qualitative research is not to generalize the information but to clarify the specific. Therefore, as the researcher of this study, I could observe three teachers which took 12 lessons a week. If I had chosen to study with more number of teachers, I could not have observed all teachers' lessons because of some overlaps in their schedules. Table 3.1 summarizes the information about the teachers who participated in this study.

**Table 3.1** Information about the participants

<b>Teachers</b>	<b>Gender</b>	<b>Teaching years</b>	<b>Education</b>	<b>Other experiences</b>	<b>School type</b>	<b>Professional Development</b>
<b>Betül</b>	Female	3	B.S.	-1 year teaching experience in a private teaching institution	Private School	In-service training about new chemistry curriculum
<b>Simge</b>	Female	12	M.S.	-1 year teaching experience in a private teaching institution -Teaching in different private school	Private School	In-service training about new chemistry curriculum
<b>Burak</b>	Male	20	B.S.	-Electric technician in a factory -Teaching in different private school	Private School	In-service training about new chemistry curriculum

### 3.4. The Subject Matter and Topic Selection

The topic of reaction rate and chemical equilibrium topics were chosen for several reasons. First, although two of the observed participants had been teaching these two topics for years, the novice teacher taught them for the first time that year. The novice teachers had been working in this school for 2 years; however, she had not taught these two topics before. She had taught chemistry topics in the 9<sup>th</sup> and 10<sup>th</sup> grade chemistry curriculum before conducting this study. In the third year of her teaching experience at this school, she started to teach chemistry topics in the 11<sup>th</sup> grade chemistry curriculum. Therefore, I decided to select chemistry topics from 11<sup>th</sup> grade level. The topics taught in the 11<sup>th</sup> grade curriculum are enthalpy,

electrochemistry, reaction rate, and chemical equilibrium respectively at the time of study. Among these topics, I selected reaction rate and chemical equilibrium topics. Second, scarcity of research on teachers' PCK and on interaction among PCK components for teaching reaction rate and chemical equilibrium made me concentrate on these topics. Third, it was a well attested fact that a significant number of high school students struggle with understanding the concepts related to reaction rate and chemical equilibrium (e.g., Van Driel et al., 1998; Tyson et al., 1999; Voska & Heikkinen, 2000; Cakmakci, 2010). Fourth, the two topics I would select had to be at the same grade level because orientation to science teaching is grade specific (Magnusson et al., 1999). Reaction rate and chemical equilibrium are taught in 11<sup>th</sup> grade in order. Finally, the time for observing these two topics was at researchers' convenience. Before starting to observe the teachers, I had to take permissions both from my department and the school administration. I also prepared data collection sources before starting the observations of instructions (e.g., card-sorting task).

### **3.5. Context of the Study**

The participants were selected from the same context which was a private high school in Ankara. The objective of this study was to compare and contrast interactions among PCK components of novice and experienced teachers not to compare and contrast teachers in different contexts. Therefore, I chose them from the same context. As a result, the teachers could teach the topics with the same curricular and instructional materials. In addition, I observed the teachers in their real classrooms instead of bringing them in to a contrived situation.

In the private school, there were 693 students at the time of the study. There were 144 11<sup>th</sup> grade students consisting of 65 boys and 79 girls. Among 11<sup>th</sup> grade students, 81 students were in the branch of science and mathematics. There were four science and mathematics classes, I chose three of them for this study. The average class size was 20, including approximately 10 girls and 10 boys. The 11<sup>th</sup> grade students' ages ranged between 16 and 18. In addition to the book offered by Ministry

of National Education [MoNE] (2000), they also used another book that was General Chemistry written by Chang and Overby (2011). The language of instruction at this school is English.

In this context, the classrooms have smart boards and computers as well as benches, chemicals and equipment to perform experiments and demonstrations at the back of classrooms (see Figure 3.1). The teachers usually used smart boards and power point slides while teaching the topics. When needed, the teachers can make demonstrations. They sometimes planned experiments for students. Moreover, in the chemistry department group meetings, all teachers shared their ideas, problems and difficulties regarding their students as well as instructional materials. In addition, they prepared instructional materials and also shared work.

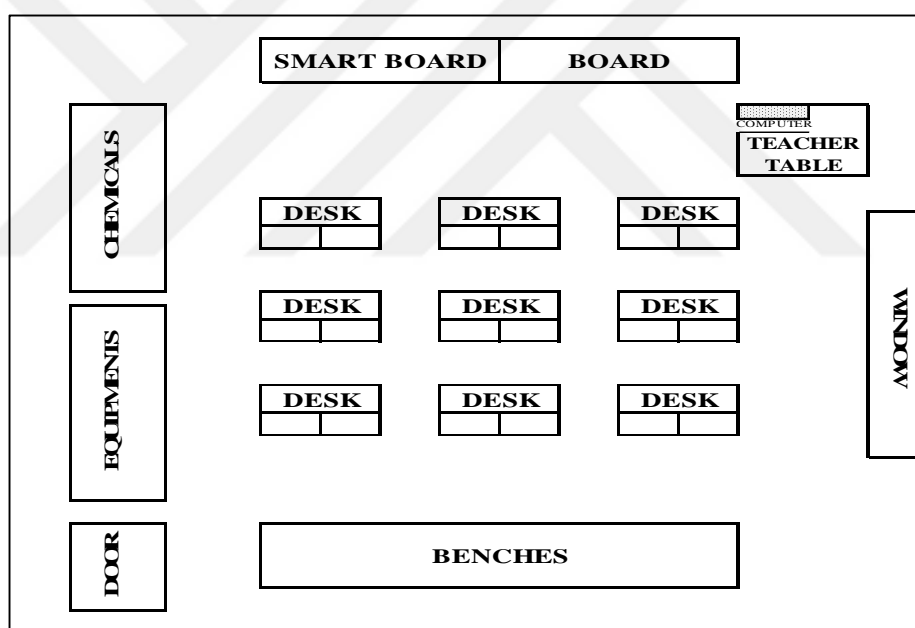
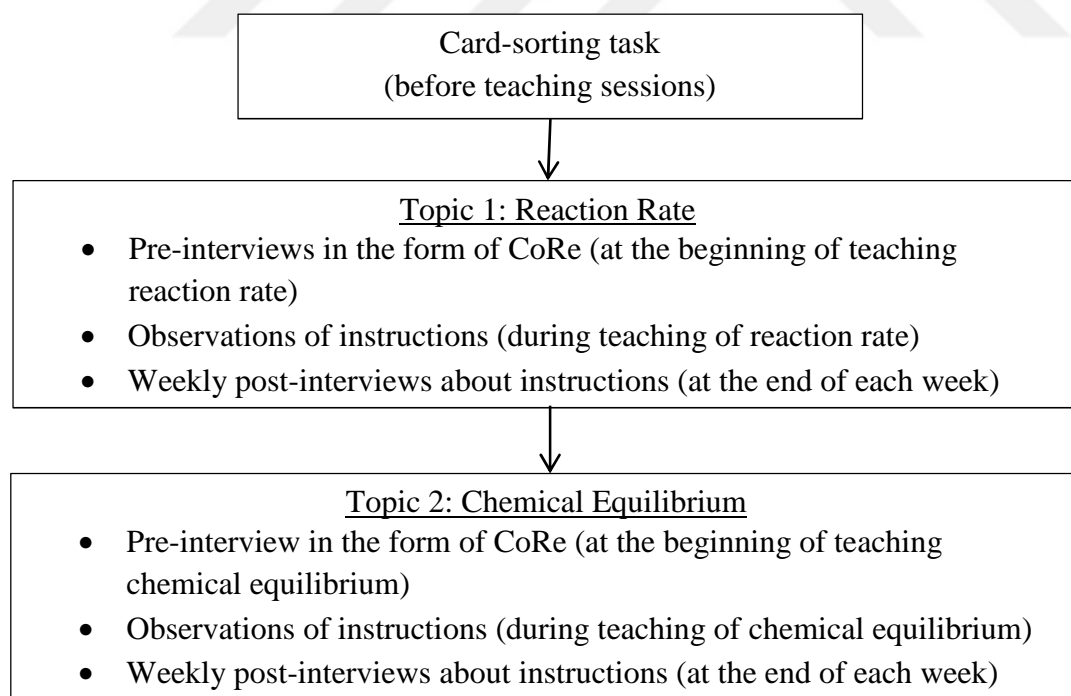

**Figure 3.1** Arrangement of the classroom

### 3.6. Data Collection Sources

Qualitative researchers typically gather multiple forms of data and spend notable time in the natural setting to collect information (Creswell, 2007). In qualitative research, the data collection procedures include four basic types: observations (ranging from nonparticipant to participant), interviews (ranging from

close-ended to open-ended), documents (ranging from private to public), and audio-visual materials (involving materials like videotapes, photographs, compact disks) (Creswell, 2007). In this study, multiple sources of data were used because the complexity of teachers' knowledge cannot be captured by a single instrument (Kagan, 1990). In this regard, in order to gain in-depth information about the interplay among PCK components of the participants, multiple sources of data such as card-sorting task, pre-interviews in the form of CoRe, observations of instructions, field-notes, and post-interviews about the instructions were employed. Figure 3.2 displays the data collection stages in order. Before starting the observation of teachers' instructions, card-sorting task was employed. In addition, pre-interviews in the form of CoRe were conducted at the beginning of each topic. Then, all teachers' instructions were observed during the teaching of reaction rate and chemical equilibrium topics. At the end of each week, post-interviews were conducted. Data were collected over a two-month period. In the following parts, all these data sources will be explained in detail.



**Figure 3.2** The data collection stages

### 3.6.1. Card-sorting Task

To diagnose the participants' science teaching orientations for teaching chemistry, card-sorting task was conducted. The card-sorting task which was developed by the researcher based on Friedrichsen and Dana (2003) was utilized before the teachers' instruction. The objective was to elicit teachers' purposes and goals for teaching chemistry.

The root of this study is based on Magnusson et al.'s (1999) PCK model. However, the researcher did not only keep to this model regarding science teaching orientations. Friedrichsen and Dana (2005) and Friedrichsen et al. (2011) criticized Magnusson et al.'s (1999) definition and categorization of science teaching orientation component of PCK. Friedrichsen and Dana (2005) argued against labeling teachers' orientations with a single orientation. Instead, their orientations are more complex and broader in scope than those identified in the literature. Moreover, they claim that matching participants' orientations to those defined in the PCK literature is insufficient for characterizing their orientations. Teachers might have multiple science teaching orientations which are more complex and specific to courses than identified in the literature (Friedrichsen et al., 2011). To show this complexity, Friedrichsen and Dana (2005) propose to use both central and peripheral components to better present teachers' science teaching orientations which include goals related to general schooling, the affective domain, and subject matter. In this regard, while developing and writing scenarios, I took chemistry curriculum goals stated in the Turkish chemistry curriculum (MoNE, 2011), the goal related to preparation for high stakes university entrance exam, and science teaching orientation categorization of Magnusson et al.'s (1999) into consideration. The scenarios reflecting Magnusson et al.'s (1999) science teaching orientations were about didactic, activity-driven, discovery, conceptual change, academic-rigor, guided-inquiry, project-based science and process. In addition to these orientations, I added some goals from Turkish chemistry curriculum (MoNE, 2011). The goals are: i) to develop an understanding of the historical improvement of basic concepts of the matter (history of science), ii) to develop an understanding of the effects of these

concepts on individuals, social, economic and technological world (science-technology-society, STS), iii) to develop skills for utilizing chemical terminology for explaining those concepts or models (Terminology).

Then, I designed 12 cards including scenarios related to teaching rate of reaction and chemical equilibrium topics. These scenarios described an instructional strategy, planning technique, laboratory activity, or assessment strategy mostly utilized in high school chemistry teaching. One of the sample scenarios is “As a chemistry teacher, you have decided that the best way to teach how rate of a reaction changes in time is to let students discover the relation between time and rate of reaction on their own” (Discovery). Another scenario is “As a chemistry teacher, you have decided that the best way to teach the difference between instantaneous and average rate is to use lecturing and writing the formulas of them on the blackboard” (Didactic). All scenarios were added in Appendix A. After the scenarios were prepared, two experts in chemistry education checked their grammar, wording, and whether they were consistent with the orientation categorization of Magnusson et al.’s (1999) and national chemistry curriculum goals. Then, the scenarios were piloted with two chemistry preservice teachers in order to check whether the card-sorting task worked in the way I intended.

Before observing the teaching sessions, teachers were requested to sort the cards into three categories, namely representative (i.e., scenarios that best represent their teaching), not representative (i.e., scenarios that do not represent their teaching) and unsure (i.e., scenarios that teacher is not sure whether s/he teaches in that way). During card-sorting task, I wanted the teachers to think aloud because what the teacher said during the card-sorting task provided more insight into their science teaching orientations than how the teacher sorted the specific cards (Friedrichsen & Dana, 2003). As an interviewer, I also took notes regarding which scenarios evoked negative and positive reactions. For instance, one of the participants shook her head and stated “I have used this approach before and the students did not like it, and so I will not teach it this way.” Another participant quickly and decisively dismissed one of the scenarios. After sorting the cards into the categories, the teachers were

requested to describe how the scenarios in the representative categories reflected their purposes and goals for teaching chemistry. They were asked in which aspects of their teachings were similar to or different from those defined in the cards. Conducting this task and the semi-structured interviews took approximately 45 minutes. All the interviews including the card-sorting task were audio-taped and transcribed verbatim. The interview questions used after sorting the cards were prepared in the light of the literature (e.g., Friedrichsen & Dana, 2003; Aydin, 2012). The questions are as follows: How does this scenario support your purposes and goals for teaching chemistry?, Which aspects of this scenario are similar to your teaching?, For the representative category, what are the common properties of the scenarios?, In addition to these strategies in the scenarios, what additional strategies will you use while teaching reaction rate and chemical equilibrium topics?, Why do you put the cards in to the not representative category?, For the not representative category, what are the common properties of the scenarios?, Which aspects of the scenario in the not representative category would you change if you wanted to use them?, For the unsure category, what are the common properties of the scenarios?, Why do you think that they do not totally reflect your teaching?

### **3.6.2. Interviews**

Interviewing was an essential part of data collection for this study because the participants' feelings, notions and interpretations could not be observed. The aim of conducting interviews is to elicit someone's perspective and opinions (Patton, 2002; Creswell, 2009). The inquirer wants to elicit "...what is in and on someone else's mind, to gather their stories" (Patton, 2002, p.341). In a similar vein, the interplays among PCK components of novice and experienced teachers could not easily be observed; therefore, interviews were conducted in this study.

Interviews involve face to face interviews with participants, interviews by telephone, or group interviews (Creswell, 2009). The range of structure of these interviews varies from highly structured to unstructured formats. In highly structured interviews, questions and the order of the questions are predetermined. On the other

hand, in unstructured interviews, questions are not predetermined and the interview is basically exploratory. These interviews are usually used when the inquirer does not have enough knowledge about a phenomenon to ask related questions. Semi-structured interviews have a place in the middle between structured and unstructured interviews and include less structured interview questions worded more flexibly. In semi-structured interviews, the questions are more flexibly worded or consist of both more and less structured questions (Merriam, 2009). In these interviews, the interview guide may consist of several particular questions to provide the same basic lines of inquiry which are directed with each person during the interview (Patton, 2002). Interviewing in qualitative research is generally more open-ended and less-structured.

In this study, I conducted semi-structured interviews which were pre-interviews in the form of CoRe at the beginning of each topic and weekly post-interviews about the instructions. In general, in these semi-structured interviews, in order to capture and represent the teachers' PCK, a set of questions pertaining to teaching procedure, instructional activities/representations/materials, and the reason why they used them were asked through the theoretical lens of PCK.

### **3.6.3. Pre-interviews in the Form of Content Representations (CoRe)**

The CoRe (Appendix B) is a matrix including big ideas/concepts about the topic (e.g., Le Chatelier's principle, factors affecting rate of reaction) in the horizontal axis. In the vertical axis, there are factors that affect teachers' decisions on such issues as learners' difficulties and ways of assessing students' understanding of concepts (Loughran, Mulhall, & Berry, 2004). The CoRe was developed in response to the difficulties in capturing and portraying PCK with traditional ways (Loughran et al., 2004). A teacher's PCK may not be apparent to an inquirer within the boundaries of one lesson or teaching experience. In addition, because of being partly an internal construct, observations can ensure solely limited insight into a teacher's PCK (Baxter & Lederman, 1999). With this in mind, Loughran et al. (2004) developed the CoRe as a research tool with the aim of attempting to capture,

document, and portray science teachers' PCK. It helps us attain science teachers' understanding of the content as well as a way of representing this knowledge (Loughran et al., 2004). In other words, it is used for both capturing PCK and as a way of portraying this knowledge to others (Loughran et al., 2004). It is a useful tool for talking about teachers' topic-specific PCK as well descriptions of their practice.

Similarly, in this study, I used the CoRe as a research tool for capturing PCK and the interactions among PCK components, and as a way of portraying this knowledge to others. Similar to Loughran et al. (2004), I utilized the CoRe as a pre-interview tool with all teachers before they started to teach both rate of reaction and chemical equilibrium topics. In the pre-interviews, I mainly asked the items in the CoRe to deeply understand the teachers' topic-specific nature of PCK about the two topics and how the participants will construct their instructions. In these semi-structured pre-interviews, I prepared an interview guide (see Appendix C) mainly based on CoRe tool as well existing literature (e.g., Loughran, Milroy, Berry, Gunstone, & Mulhall, 2001; Loughran et al., 2004; Henze et al., 2008; Aydin, 2012, Demirdöğen, 2012). During these interviews, I asked also some follow-up questions to understand how they will integrate PCK components while teaching reaction rate and chemical equilibrium topics. The questions are as follows: What are the difficulties related to teaching reaction rate topic?, Which teaching strategies are you going to use to teach reaction rate topic?, What are the specific reasons for using them?, Which assessment techniques are you going to use to assess students' understanding of chemical equilibrium topic?

Each interview took approximately 40 minutes to one hour. All the interviews were audio-taped and transcribed verbatim.

#### **3.6.4. Observation of Instructions**

Observations are also primary data source as interviews and provide some knowledge of the context, specific events and behaviors (Merriam, 2009). Moreover, these observations can be utilized as reference points for following interviews (Merriam, 2009). Accordingly, one of the important aspects of PCK is the translation

of teachers' knowledge into classroom practice; therefore, we make observations for their actual teachings (Baxter & Lederman, 1999). Therefore, I conducted observations to gain some knowledge about context, specific events and behaviors of the participants (Merriam, 2009). After employing the CoRe, I observed the participants' teaching sessions through the theoretical lens of PCK. By observing the teachers in their own classrooms, I gained a better understanding of their actual teaching practices and the context in which they taught.

In a qualitative research, inquirers take field notes about the behavior and activities of individuals. In these field notes, the inquirers write down activities at the research field in a semi-structured (utilizing some prior questions that the researcher wants to know) or unstructured way (Creswell, 2009). Accordingly, I observed and took field notes during all teachers' instructions in order to capture the important aspects of their teaching through the theoretical lens of PCK. While taking field notes, I tried to be highly descriptive. These field notes included verbal descriptions (i.e., descriptions of the setting, the teachers, and the activities done in the classrooms), direct quotations of what the teachers said, and observer's comments, judgments and ideas related to the observed events (Merriam, 2009). The roles of qualitative observers may change from a non-participant to a complete participant (Creswell, 2009). In the present study, I had a non-participant role (i.e., complete observer), and so I only observed all lessons of the teachers by taking field notes without participating. For each participant, one of their 11<sup>th</sup> grade classes was selected and observed from the beginning to the end of teaching each topic. I spent a considerable amount of time for observing teachers in their classrooms. Each of the class periods was 40 minutes. Specifically, I observed each participant's 17 class sessions for reaction rate and 18 class sessions for chemical equilibrium topics, with field notes serving as a data source. This enabled me to obtain a more complete picture of what goes on in their classrooms. More importantly, the data gained through observations helped me to formulate my post-interview questions. For instance, when I observed that one of the teachers used an instructional strategy (e.g.,

analogy, demonstration, etc.), I asked the reason why s/he used that strategy and how that strategy helped the teacher attain her/his goals.

All class sessions of the two topics were recorded on audiotape and then transcribed verbatim. Additional data consisted of students' assignments, worksheets, and lab manuals that were handed over to the researcher during teaching sessions.

### **3.6.5. Post-interviews about Instructions**

After observing the teachers' instructions, I conducted weekly face-to-face and semi-structured post-interviews in combination with classroom observations in order to probe the novice and experienced chemistry teachers' PCK as well as the sources of their knowledge. In those weekly post-interviews about instructions, I asked questions to gain an in-depth understanding of the teachers' PCK and its components, teachers' use of different instructional strategies and assessment techniques. In addition, I asked the reasons why they used them, how they decided to use them, and whether these strategies helped the students comprehend the topic. Thanks to these interviews, the teachers had opportunities to revisit their instruction and to articulate the reasons for their instructional decisions. After each instruction, I prepared the weekly post-interview questions based on my observations and field notes to capture and portray the teachers' PCK and the interactions among PCK components. While preparing the semi-structured interview questions, the existing literature guided the researcher (e.g., Loughran et al., 2004; Henze et al., 2008; Aydin, 2012). Sample interview questions are as follows: Why did you use an analogy while teaching state of equilibrium?, How do you think that analogy helps students learn about this topic?, What knowledge about students did you use when doing the demonstration about rate of reaction?, Why did you assess your students' understanding by using that assessment technique?

Each interview took approximately 30 minutes. All the interviews were audio-taped and transcribed verbatim. All data sources along with purposes, uses, and duration are summarized in Table 3.2.

**Table 3.2** A summary of all data sources

<b>Data Source</b>	<b>Why used</b>	<b>How used</b>	<b>When used</b>	<b>Duration</b>
<b>Card-sorting task</b>	To diagnose the participants' purposes and goals for teaching chemistry	Cards including scenarios were prepared. The participants were requested to sort the cards into three categories and asked the reason of their choices. The interviews were audio-taped.	Before teaching sessions	About 45 minutes
<b>Pre-interview in the form of CoRe</b>	To capture, document and portray the teachers' PCK in reaction rate and chemical equilibrium topics and interactions among the PCK components	CoRe items and the questions in the interview guide were asked in the interviews. The interviews were audio-taped.	At the beginning of teaching both reaction rate & chemical equilibrium topics	About 40 minutes to 1 hour
<b>Observations of instructions</b>	To collect data about the nature of the teachers' PCK and the interplay among the components	Field notes were taken. All lessons were audio-taped.	Throughout teaching of reaction rate and chemical equilibrium	Each of the class periods was 40 minutes. 17 class sessions for reaction rate and 18 class sessions for chemical equilibrium were observed.
<b>Weekly post-interviews about instructions</b>	To probe the participants' PCK, and the interactions among the components	Post-interview questions about the teachers' instructions were conducted. The interviews were audio-taped.	At the end of each week	About 30 minutes

### **3.7. Data Analysis**

Data analysis is the process of making sense out of text and image data in order to answer research question(s). Making sense out of the data includes consolidating, reducing, and interpreting what participants have said and what the inquirer has seen and read (Merriam, 2009). Data analysis is a complex and ongoing process that includes "...moving back and forth between concrete bits of data and abstract concepts, between inductive and deductive reasoning, between description and interpretation" (Merriam, 2009, p. 176). These meanings or insights compose the findings of the study. Findings might be in the form of "...organized descriptive accounts, themes, categories that cut across the data, or in the form of models and theories that explain the data" (Merriam, 2009, p. 176).

The data analysis procedure involves several steps (Creswell, 2009):

1. Organize and prepare the data for analysis: It consists of transcribing interviews, typing up field notes, classifying and organizing the data into various types depending on the sources of information. In the present study, first, I completed all field notes by listening audio records taped throughout teaching sessions. Then, I started to transcribe all interview data and created electronic files for them. In addition, I arranged all instructional materials into files.
2. Read through all the data: After organizing the data, in order to get a general sense of the information and become familiar with the data, I read and reread all data carefully. I also wrote some notes in margins at this stage.
3. Coding process: Coding is the process of taking text data or pictures collected during data collection, dividing sentences/paragraphs or images into categories, and labelling those categories with a term. During the coding process, the researcher can (a) improve codes only on the basis of emerging information gathered from participants, (b) utilize predetermined codes and then adjust the data to them or (c) utilize some integration of predetermined and emerging codes.

In this study, I used both predetermined and emerging codes as Creswell (2009) stated. As a first step, I used the predetermined codes and fit the data to them. These predetermined codes used in this study directly came from PCK literature. Magnusson et al.'s (1999) PCK model with its components formed the codes in this study. Therefore, five components of PCK which are science teaching orientation, knowledge of learner, knowledge of instructional strategies, knowledge of curriculum, and knowledge of assessment were the main codes of this study. There were sub-codes under these main codes. For science teaching orientation component, in addition to Magnusson et al.'s (1999) science teaching orientation categorization, I added some extra sub-codes. These extra sub-codes were chemistry curriculum goals stated in the Turkish chemistry curriculum (MoNE, 2011), and the goals related to preparation for high stakes university entrance exam into consideration. The predetermined sub-codes for science teaching orientation were didactic, activity-driven, discovery, conceptual change, academic-rigor, guided-inquiry, project-based science, process, history of science, science-technology-society, terminology, and high stakes university entrance exam. In addition to these sub-codes, I developed a sub-code on the basis of the emerging information collected from the participants. While observing teaching sessions and then reading the data, I realized that some of participants had a goal about to relate chemistry to daily life. I named this goal as everyday coping (Roberts, 1988). For knowledge of curriculum component, the sub-codes were knowledge of goals and objectives, vertical curriculum and horizontal curriculum. For knowledge of learner, the sub-codes were knowledge of requirements for learning, knowledge of areas of student difficulty and knowledge of areas of student misconception. For knowledge of instructional strategies component, the sub-codes were knowledge of subject-specific strategies, and knowledge of topic-specific strategies. Moreover, knowledge of topic-specific strategies consists of knowledge of representations and knowledge of activities sub-codes.

Knowledge of assessment includes teachers' knowledge of what to assess and how to assess sub-codes. Then, I developed PCK coding table that includes a list of predetermined and emerging codes in one column, sub-codes in another column, and a definition of sub-codes in last column (see Appendix D). This coding table was used by another expert to code the data in order to ensure reliability.

4. Generate categories and themes for analysis: After coding the data, I generated categories inductively to analyze the possible interactions among PCK components. Based on the observations of instructions and interview transcripts, I generated 10 categories reflecting all possible two-way interactions among PCK components. I prepared a table to show all possible interactions among the components (i.e., categories) and their explanations (see Table 3.3). After analyzing all data based on these categories, for each participant I prepared PCK maps, which is explained in detail under the heading of "Data Analysis for Interactions among PCK Components". Then, I examined these PCK maps for generating themes and patterns. All the issues of validity and reliability for coding process are discussed under the heading of validity and reliability of the study.

**Table 3.3** Categories for analyzing data and their explanations

<b>Categories</b>	<b>Explanation</b>
STO – KoIS Interplay	Utilizing a specific instructional strategy to attain goals and purposes for science teaching
KoIS – KoC Interplay	Utilizing a specific instructional strategy to address a particular curriculum objective
KoIS – KoL Interplay	Utilizing a specific instructional strategy to handle a difficulty, misconception or pre-requisite knowledge
KoA – KoIS Interplay	Reviewing the instructional strategies according to the feedback taken from assessments
KoA – KoL Interplay	Utilizing different assessment methods to specify students' difficulties, misconceptions or pre-requisite knowledge
KoL – KoC Interplay	Taking a difficulty, misconception, or pre-requisite knowledge into consideration while examining the curriculum regarding what students have learned so far and will learn about those topics
KoL – STO Interplay	Taking students' difficulties, misconceptions or pre-requisite knowledge into consideration according to teacher's goals and purposes for science teaching
KoC – STO Interplay	Taking a particular curriculum emphasis in class (i.e., nature of science objectives) into consideration according to teacher's goals and purposes for science teaching
KoA – KoC Interplay	Utilizing different assessment methods to define learners' achievement regarding the goals and objectives related to the subjects, or to bring out what students know about the topic within a grade and across grades
KoA – STO Interplay	Assessing a particular knowledge or skill for determining whether students reached teacher's goals and purposes for science teaching

STO: Science teaching orientations, KoL: Knowledge of learner, KoC: Knowledge of curriculum, KoIS: Knowledge of instructional strategies, KoA: Knowledge of assessment.

5. Advance how the description and themes will be represented in the qualitative narrative: To use a narrative passage is the most common approach for conveying the findings of the qualitative analysis. This can be a discussion of a chronology of events, the detailed discussion of themes, or a

discussion with interconnecting themes. In addition to the discussions, visuals, figures, or tables are used. In this study, after producing themes and patterns based on PCK maps, I generated tentative assertions based on these themes and patterns. Finally, I discussed the findings under these assertions by using interview excerpts, specific illustrations, multiple perspectives from individuals, and descriptive information about each participant.

6. Make an interpretation or meaning of the data: In this step, the researcher should derive a meaning by comparing findings with information collected from the literature or theories. Furthermore, when the researcher utilizes a theoretical lens, s/he can generate interpretations that call for action agendas for reform and change. As a result, as a researcher of this study, I tried to derive a meaning by comparing the findings with information gleaned from PCK literature. I tried to explain the similarities and differences among the findings, create cause-effect relationships, derive some conclusions based on the findings, and manifest the importance of the findings. Moreover, I tried to derive in which aspects of the findings confirm past information or diverge from it.

After explaining six step of data analysis, I explained different techniques used for data analysis for science teaching orientations and interactions among PCK components in detail in the following parts.

### **3.7.1. Data Analysis for Science Teaching Orientations**

This study included an analysis of the participants' science teaching orientations to gain a better understanding of the interactions, because of its pivotal position in the PCK model. While collecting the data through card-sorting task, classroom observations, and weekly post-interviews about instructions, I have realized that participants' science teaching orientations were complex, with each participant having multiple goals and purposes for teaching chemistry. Similar to Friedrichsen and Dana (2005), I analyzed their orientations by using two categories: central and peripheral goals. First, the participants' science teaching orientations

were coded according to the pre-determined and emerging codes: didactic, activity-driven, discovery, conceptual change, academic-rigor, guided-inquiry, project-based science, process, history of science, science-technology-society, terminology, high stakes university entrance exam and everyday coping. Then, their orientations were analyzed based on two categories which were central and peripheral goals. Friedrichsen and Dana (2005) define central goals as a component dominating “the teacher’s thinking and [it] appeared to drive the instructional decision-making process” (p.225). During classroom observations and in curriculum units, these goals are highly apparent and explicit (Friedrichsen & Dana, 2005). In addition, participants may have a variety in the number of central goals presented in their science teaching orientations. For instance, Burak had four central goals (everyday coping, didactic, conceptual change, and process), whereas Betül had one central goal (didactic). In addition, Friedrichsen and Dana (2005) described a secondary set of goals (i.e., peripheral goals). These goals do not define the design of the course; however, still they play a role in teacher’s thinking. They have less effect in instructional decision-making process than the central goals. To illustrate, Burak’s peripheral goals were academic-rigor, activity-driven and preparing learners for high stakes university entrance exam while Betül’s peripheral goals were activity-driven and process.

### **3.7.2. Data Analysis for Interactions among PCK Components**

After analyzing the participants’ science teaching orientations, I focused on the data analysis for possible interactions among PCK components. In addition to fulfilling the requirements for data analysis procedure mentioned above, I employed Park and Chen’s (2012) approach based on the pentagon model (Park & Oliver, 2008b) to investigate the interactions among the components. A stepwise procedure for the data analysis for interactions among PCK components was performed: In-depth analysis of explicit PCK, enumerative approach, and constant-comparative method. All these approaches will be explained in the following parts.

### **3.7.2.1. In-depth analysis of explicit PCK**

In-depth analysis of explicit PCK (Park & Oliver, 2008a; Park & Chen, 2012) was used in order to designate the components integrated into a teacher's PCK in a particular "teaching fragment". In this approach, I first defined "teaching fragment" from the teachers' instructions, which include an integration of two or more PCK components in the pentagon model. In other words, a teaching fragment represented the existence of two or more PCK components. In addition, a teaching fragment reflected what the teacher and students did, the teacher's and students' role, which components of PCK were interplayed and evidence of the presence of the portrayed components. This delineation was derived mainly from observations of instructions, but completed through interviews and instructional documents used in teaching fragments. In order to determine whether a connection was obvious in any of the data source, I used the categories explained before (see table 3.3). For instance, participants' use of a specific teaching method to address a specific curriculum objective portrays a connection between knowledge of curriculum and instructional strategies. A teacher might design an instruction in which students make an experiment in order to address the objective in the chemistry curriculum [students understand the effect of catalyst on rate of reaction]. Additionally, these teaching fragments constituted the unit of analysis for this study (Merriam, 2009)

### **3.7.2.2. Enumerative approach**

Enumerative approach was used to present the interplays among PCK components in a clear and explicit way (LeCompte & Preissle, 1993). After employing in-depth analysis of explicit PCK and identifying teaching fragments, the interactions among the PCK components were presented by utilizing the pentagon model as an analytic device. This analytic device was named PCK map (Park & Chen, 2012). As seen in Figure 3.3, each map involves circles indicating each PCK component. When I found a connection between any of the two components in the data, I showed that connection on the map with a link between the related components. Assume that one interaction was detected among knowledge of learner,

curriculum, and instructional strategies as depicted in Figure 3.3. I assumed the same strength of 1 for each link on PCK maps for analytic convenience similar to what Park and Chen (2012) did.

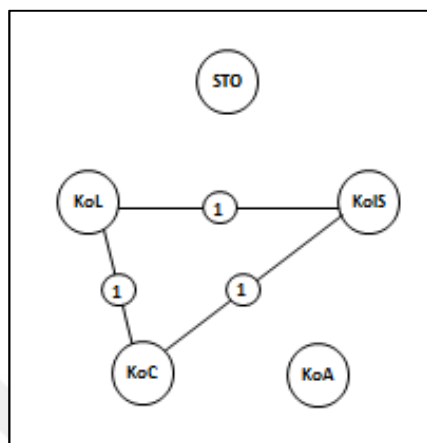

**Figure 3.3** Example of the first step of the enumerative approach  
STO: Science teaching orientations, KoL: Knowledge of learner, KoC: Knowledge of curriculum, KoIS: Knowledge of instructional strategies, KoA: Knowledge of assessment

The same procedure was followed for all teaching fragments. The frequency of the link between any of the two PCK components was summed up across all teaching fragments and it was represented on the PCK Map. Therefore, the numbers on the line designate the frequency of the interactions between any of the two components. For instance, Figure 3.4 shows Simge's PCK map for chemical equilibrium topic.

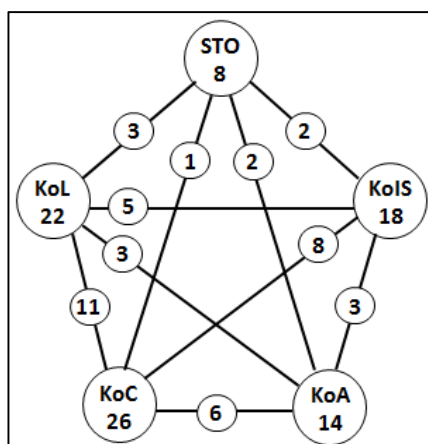

**Figure 3.4** Simge's PCK map for teaching of chemical equilibrium

STO: Science teaching orientations, KoL: Knowledge of learner, KoC: Knowledge of curriculum, KoIS: Knowledge of instructional strategies, KoA: Knowledge of assessment

This map indicates that there are eight teaching fragments identified, and in these fragments knowledge of curriculum and instructional strategies are interconnected. Moreover, there are three teaching fragments identified and in these fragments knowledge of assessment and instructional strategies are connected. The more interactions among PCK components a teacher had, the more interactions on PCK map are. On a PCK map, the frequency of each link demonstrated the strength of the link, because each link is given "1" for its strength. Therefore, the higher the frequency of the link is, the stronger the link becomes (Park & Chen, 2012).

In addition, the numbers in each circle indicate how many times the components were linked with other components on the PCK map. For example, knowledge of assessment was connected 14 times with the others, while knowledge of instructional strategies was connected 18 times with the other components. Finally, I constructed all participants' PCK maps for both teaching reaction rate and chemical equilibrium.

### **3.7.2.3. Constant-comparative method**

After identifying teaching fragments and constructing PCK maps for the teachers, constant-comparative method (Glaser & Strauss, 1967) was used to diagnose common patterns and regularities among the PCK maps without using any prior categories or framework. Constant comparative method of data analysis is primarily inductive and comparative (Merriam, 2009). According to this method, one fragment of data was compared with another one to decide similarities and differences, and then the data are grouped together under a similar dimension. This dimension is tentatively given with a name, and it presents a category or a theme. Identifying patterns in the data is the overall purpose of this analysis. Accordingly, in this study, all PCK maps for each topic were compared and contrasted in order to recognize the similarities and differences between them. Then, they were ultimately grouped under similar themes and patterns. Consequently, the identification of these themes and patterns indicated nine assertions for the integration of PCK components.

### **3.8. Reliability and Validity Issues of the Study**

Ensuring validity and reliability in a qualitative research is different from quantitative research, because their research designs are based on different assumptions. Therefore, many writers should keep validity and reliability from a perspective appropriate with the philosophical assumptions underlying the paradigm (Merriam, 2009). These resulted in naming the terms differently while dealing with issues of validity and reliability in qualitative research (Lincoln & Guba, 1985). Lincoln and Guba (1985) recommend using credibility, transferability and dependability respectively instead of using internal validity, external validity and reliability. Several strategies were offered in order to improve the validity and reliability of qualitative studies. The following parts will present what the strategies appropriate for maintaining the dependability, credibility, and transferability in the study are.

### 3.8.1. Dependability

Dependability or qualitative reliability displays the consistency of the researcher's approach with different inquirers and different projects (Gibbs, 2007). Creswell (2007) stated that dependability often refers to the "...stability of responses to multiple coders of data sets" (p.210). Merriam (2009) emphasized that whether the findings are consistent with the data gathered is one of the most important questions in qualitative research. In order to ensure dependability of this study, several procedures offered by Gibbs (2007) were followed. First, I checked all transcripts to ensure that they did not include any evident mistakes made during transcription. Second, I tried to ensure that there was not a drift in the description of codes, a shift in the meaning of the codes throughout the coding process. I tried to overcome this by constantly comparing the data with the codes and by writing notes about the codes and their description. Third, cross-checking or intercoder agreement was conducted to determine the level of consistency of the coding. This intercoder agreement shows whether two or more coders agree on codes utilized for the same part of the text. In this study, an external coder who has experience on qualitative research, chemistry education, and PCK and I coded the interview data to determine the level of coding consistency. I gave the PCK coding table to the external coder to be able to identify categories for analyzing data. We coded one of the interview data independently for possible interactions among PCK components in teaching fragments and then compared our coding. The important key issue was determining whether the same teaching segments were coded in the same way. We mainly agreed on the coding; however, some discrepancies between codes were seen. At this point, I calculated inter-rater reliability to decide the consistency among the number of same interactions of PCK components. To do this, I used a formula recommended by Miles and Huberman (1994) to calculate reliability as:

$$\text{Reliability} = \frac{\text{Number of agreements}}{(\text{Total number of agreements} + \text{disagreements})} \times 100$$

Initial agreement on the coding of the data was calculated as 88%. For good qualitative reliability, Miles and Huberman (1994) suggested that the consistency of the coding should be in agreement at least 80% of the time. After resolving inconsistencies between the coders, we coded another interview data independently. Finally, we reached about 95% agreement, revealing a good level of agreement.

### **3.8.2. Credibility**

Credibility means deciding whether the results are accurate from the standpoint of the researcher, the participant, or the readers of an account. Credibility is interested in the question how research results match reality (Merriam, 2009). Therefore, the inquirer should check for the accuracy of the findings by applying several strategies such as triangulation, member checking, prolonged engagement, peer debriefings, clarifying the bias, and negative case analysis (Creswell, 2009).

The present study incorporated triangulation, member checking, prolonged engagement, and peer debriefings to increase credibility of the findings of this qualitative research.

#### **3.8.2.1. Triangulation**

The rationale of triangulation is based on "...the premise that no single method ever adequately solves the problem of rival explanations" (Patton, 2002, p.555). Each method brings out different aspects of empirical reality. Therefore, multiple methods of data collection and analysis provide cross-data consistency checks (Patton, 2002). According to Creswell (2007), triangulation process includes corroborating evidence from multiple sources, methods, investigators, and theories in order to enlighten a perspective or theme.

There are four different types of triangulation: methods triangulation, triangulation of sources, analyst triangulation, and theory/perspective triangulation (Patton, 2002). Methods triangulation means going through the consistency of findings produced by various data collection methods. Triangulation of sources is reviewing the consistency of various data sources within the same method. Analyst

triangulation is utilizing several analysts to examine findings. Theory/perspective triangulation is utilizing several theories or perspectives to infer the data. In order to increase credibility of this study, triangulation of sources and analyst triangulation were used. For triangulation of sources, multiple data sources involving card-sorting task, pre-interview in the form of CoRe, observations of instructions and post-interviews about instructions were utilized. By this means, I could compare and cross-check the consistency of information obtained at different times and by different instruments. For instance, I compared the participants' observations of instructions with their post-interviews about their instructions. I compared and cross-checked their card-sorting task with their observations of instructions and post-interviews about instructions. For analyst triangulation, I used one observer and one analyst. During data collection process, the observer who knows PCK literature, its components and how to observe PCK, observed all teachers' four teaching sessions in each topic. After the observations of teaching, I and the observer discussed our observations by focusing on PCK components, and then reached consensus on our discrepancies. Thus, I tried to diminish the potential bias that originated from a single person collecting all data sources. In addition, I could assess the consistency of the data gathered. Moreover, I and the analyst independently analyzed the same qualitative data and compared our findings. This analyst had experience on qualitative research, chemistry education, and PCK. We independently coded the data for possible interactions among PCK components. Then, I constructed PCK maps. After that, we independently compared participants' PCK maps. Finally, we attained a consensus on themes which were obtained inductively from these maps.

### **3.8.2.2. Member checking**

Member checking is deciding the accuracy of the findings by getting the particular definitions or themes or final report back to participants and whether these participants sense that these findings are accurate (Creswell, 2009). According to Lincoln and Guba (1985), member checking is the most important strategy for ensuring credibility. Instead of taking back the raw transcripts to check for accuracy,

the researcher should take analyses, interpretations, and conclusions back to the participants so that they can assess the accuracy of them (Creswell, 2007). After finishing in-depth analysis of explicit PCK and constructing PCK maps, I asked the participants of this study to check the data, categories, and interpretations.

### **3.8.2.3. Prolong engagement**

Spending prolonged time in the field gives the researcher a chance to develop a comprehensive understanding of the phenomenon under study (Creswell, 2009). Moreover, the researcher can deliver details about the field and the participants that contribute credibility to the narrative account. When the researcher gain more experience with participants in natural setting, findings will be more accurate or valid (Creswell, 2009). Taking all these issues into account, in this study, I spent more than two months with the participants and observed them in order to gain more experience with participants of the study. During this time, I observed their classes and talked with them about their instructions, students, curriculum, and context. This provided me an in-depth understanding of the phenomenon, the research setting and the participants of this study.

### **3.8.2.4. Peer debriefing**

Peer debriefing is used to improve the accuracy of the account. It consists of arranging a person (a peer debriefer) who checks out and asks questions about the qualitative study (Creswell, 2009). Two of my colleagues who had experience in both qualitative research and PCK helped me throughout collecting, coding, analyzing the data and interpreting the findings in order to enhance the accuracy of the account.

In addition to all these strategies, Patton (2002) argued that credibility of qualitative inquiry also depends on “*the credibility of the researcher*, which is dependent on training, experience” (p.552) and “*philosophical belief in the value of qualitative inquiry*, that is, a fundamental appreciation of naturalistic inquiry, qualitative methods, inductive analysis, purposeful sampling, and holistic thinking”

(italics are original, p.553). Before conducting the present study, I took a seminar on qualitative research in my faculty. I have read many qualitative textbooks to explore qualitative inquiry. In addition, I conducted several qualitative studies with my colleagues and I gained experience about qualitative inquiry consisting of qualitative methods, purposeful sampling, inductive analysis, and holistic thinking. All these evidence supported me to improve my credibility.

### **3.8.3. Transferability**

Transferability is concerned with what extent the findings of one study can be implemented to other situations (Merriam, 2009). This means, “How generalizable are the results of a research study?” (p.223). In order to increase the possibility of the findings of a qualitative research transferring to another situation, the best way is the use of rich and thick description. This consists of a description of the setting, participants of the study, a detailed description of the findings with sufficient evidence represented in the form of excerpts from participant interviews, observations, and documents (Merriam, 2009). To achieve transferability, the researcher of this study explicitly explained all stages of the research design involving participants, the context of the study, data collection sources, data analysis and the findings with sufficient evidence from the participants’ interviews, field notes, and documents. Another strategy for increasing transferability is to select the sample carefully.

Until now, issues of dependability, credibility, and transferability were discussed. The next parts will present database search, researcher’s background and role, ethical issues, negotiating entry, and time schedule in detail.

### **3.9. Key Words and Databases Searched**

Key terms were decided based on the literature. The initial key terms are PCK, interplay among PCK components, experienced science teachers, novice science teachers, and science education. General sources such as Educational Resource Information Center (ERIC), Science Direct, and International Dissertation Abstract

were used for searching these terms and locating primary sources. In addition, primary sources in Turkey such as Education and Science, Hacettepe University Journal of Education, Eurasia Journal of Mathematics, Science and Technology Education, Eurasian Journal of Educational Research, and Educational Science: Theory and Practice, Elementary Online, Gazi University Journal of Education, Çukurova University Journal of Education, and Kastamonu Education Journal were searched. Moreover, to reach books, I did research in several libraries in different universities (e.g., Middle East Technical University, Gazi University).

### **3.10. Researcher's Background and Role**

In qualitative research, the role of the researcher is complex and s/he is the primary instrument for collecting, analyzing and interpreting data (Merriam, 2009). Therefore, it is important to give information about the background and the role of the researcher.

As the inquirer of this research, I am a PhD candidate and a research assistant at the Department of Secondary Science and Mathematics Education in Faculty of Education in a public university. Throughout my 7-year experience as a research assistant, I assisted various undergraduate courses (e.g., Practice Teaching in Science/Mathematics Education, School Experience in Science/Mathematics Education, Instructional Technology and Material Development), and graduate courses (e.g., Research Methods in Education). Before conducting this study, I took a seminar on qualitative research given by an associate professor in my faculty. In addition, I was involved in various research studies on qualitative research and I gained experience about qualitative inquiry and methodology.

One of the important issues related to researcher role is to decide the extent to which the researcher will be a participant in the setting being investigated (Patton, 2002; Merriam, 2009). The role of qualitative researcher may change from a non-participant to a complete participant (Creswell, 2009). In the present study, I had a non-participant role (i.e., complete observer) since I aimed to examine how the teachers' integrated their PCK components into their teachings. Therefore, I only

observed all lessons of the teachers without participating. I took a seat at the back of the classroom. I observed all teachers' teaching sessions, responses of the teachers to students' questions, difficulties, and misconceptions. Throughout observations of these teaching sessions, I took as much as highly descriptive field notes.

Another important issue related to researcher role is to decide the extent to which participants in a study are informed that they are being observed and stated the purpose of the study (Patton, 2002). In a study, participants' awareness varies from full disclosure to no disclosure. Participants might act quite differently when they are aware of being observed (overt observations) while how they act naturally when they do not know they are being observed (covert observations) (Patton, 2002). The ongoing argument is that "...covert observations are more likely to capture what is really happening than are overt observations where the people in the setting are aware they are being studied" (Patton, 2002, p.269). On the other hand, Institutional Review Board (IRB) rejects to confirm research in which people are observed and studied without their knowledge or consent (Patton, 2002). The participants of this study were mostly informed that they were being observed and were told the purpose of the study. I told them the purpose of this study was to examine how they integrated their PCK components into their teaching of reaction rate and chemical equilibrium topics.

The other important issue related to researcher role is the amount of time that researcher spend in the context (Patton, 2002). Before conducting this study, I met with the teachers several times in the school. During these visits, we talked about how they teach chemistry, their weekly schedule, their backgrounds, national chemistry curriculum, and their workloads. As I explained before, I participated all teachers' teaching sessions and spent more than two months. I had to go to the school five days in a week because the teachers' weekly schedules were different from each other. During this time, I observed their teachings and conducted interviews at the end of each week about their teaching of reaction rate and chemical equilibrium. In addition, I also spent time with them during their breaks. Therefore, we had enough time to understand and trust each other.

### **3.11. Negotiating Entry**

First of all, I went to the school to meet the teachers. I explained them the purpose of the study. They reacted very positively and accepted to participate voluntarily in the study. They asked me to speak to the school principal in order to get necessary permission. After writing a letter of application, the department chair and my supervisor signed it. Then, I applied to the school to get the necessary permission. The school principal was also positive and easily approved of my study. In addition, they encouraged me to conduct a research in their school. I did not want the school administration to change anything (e.g., plan, schedule, etc.). After starting to conduct this research, I did not encounter any communication problems with the participants. I did my best to be a good listener and observer in each step of the research.

### **3.12. Ethical Considerations**

Before conducting this study, first of all, ethical standards were taken into consideration. Therefore, I applied to Institutional Review Board (IRB) and got the necessary permission for implementing the research before conducting the study (Appendix E). This board endorsed that the participants would be informed about the purpose of the study and no potential risk or harm were involved in the study. Anonymity of the school and the participants was ensured. Pseudonyms were used for all participants. In addition, all the participants voluntarily accepted to attend the study by signing a consent form. With this consent form, they were fully aware of the purpose of the study and they were informed about their rights. If they felt disturbance, they could quit participating in the study. Moreover, all participants were informed about data collection sources and the use of an audio recorder. In this way, a possible psychological harm might be prevented. Additionally, nobody except the researcher, the supervisor, and other coder had access to the data gathered for the study. Thus, all the issues pertaining to ethics in a research (deception of the participants, protection of the participants from harm, and confidentiality) were ensured.

### **3.13. Limitations of the Study**

There are several limitations of the present study: First, this study involves small number of participants and the generalizability of the results of this study may be limited. However, the intent of a case study is to broaden and generalize theories and not to make a statistical generalization (Yin, 2009). Accordingly, the purpose of this study is to broaden the theory of PCK especially in terms of the interactions of PCK components within a specific discipline and not to make a statistical generalization. In addition, one general principle in qualitative research consists of gathering comprehensive detail about research questions by studying a few sites or individuals. Therefore, I observed three teachers' classes which lasted 12 lessons a week. If I had chosen to study with more number of teachers, I could not have observed all teachers' lessons because of some possible overlaps in their schedules and could not have obtained detailed information. I tried to illuminate the readers' understanding of the phenomenon by providing rich and thick descriptions about it. The expectation is that the findings of this research may be replicated and developed upon.

Second, the existence of the researcher in the classroom might have influenced the participants' behaviors. In order to minimize my influence on the participants, I always reminded them of my intent which was to observe their classes and to talk with them about their instructions, students, curriculum, and context without criticizing and judging them.

Finally, another limitation of this study was that I assumed the same strength for each connection among PCK components while conducting the PCK map approach. This might lead to a risk of oversimplifying the complex construct of PCK (Park & Chen, 2012). Still, it is a valuable effort, because PCK map approach helped me to identify, quantify, and visualize the interplays among PCK components. Thus, I made a pictorial demonstration of the relationships among PCK components. Further studies may investigate the strength and quality of the interactions among PCK components across different topics.

### 3.14. Time Schedule

Data for the study were collected from three chemistry teachers working in a private high school in Ankara at the fall semester in the academic year of 2013-2014. A timeline showing the order of events conducted for the data collection is given in Table 3.4.

**Table 3.4** Timeline for the research

<b>Date</b>	<b>Events</b>
June 2012 - November 2012	Design of the study
November 2012 - April 2013	Development of activities and data collection sources
April 2013 - August 2013	Pilot study of the instruments and the last version of data collection tools
October 2013 - January 2014	Data collection-Implementation
July 2014 - August 2015	Data Analysis
August 2015 - November 2016	Writing results, conclusion, and discussion parts

### 3.15. Assumptions of the Study

There were several assumptions about the participants and nature of PCK, which are:

- Participants have enough subject matter knowledge in teaching reaction rate and chemical equilibrium.
- Participants are information-rich cases.
- The same strength of 1 for each link on PCK maps is assumed for analytic convenience.
- The teachers participated and answered all the questions in the interviews seriously and honestly.

## **CHAPTER 4**

### **RESULTS**

In this chapter, results of the analysis of teachers' PCK maps are presented. To do this, I carefully examined the CoRes, observation notes of instructions and pre- and post-interviews in terms of whether there existed any interaction among PCK components of teachers. As a result, the analysis of the teachers' PCK maps (see Figure 4.1) yielded nine assertions regarding the interaction among PCK components as shown in Table 4.1. In the following parts, each assertion is explained in detail with examples.

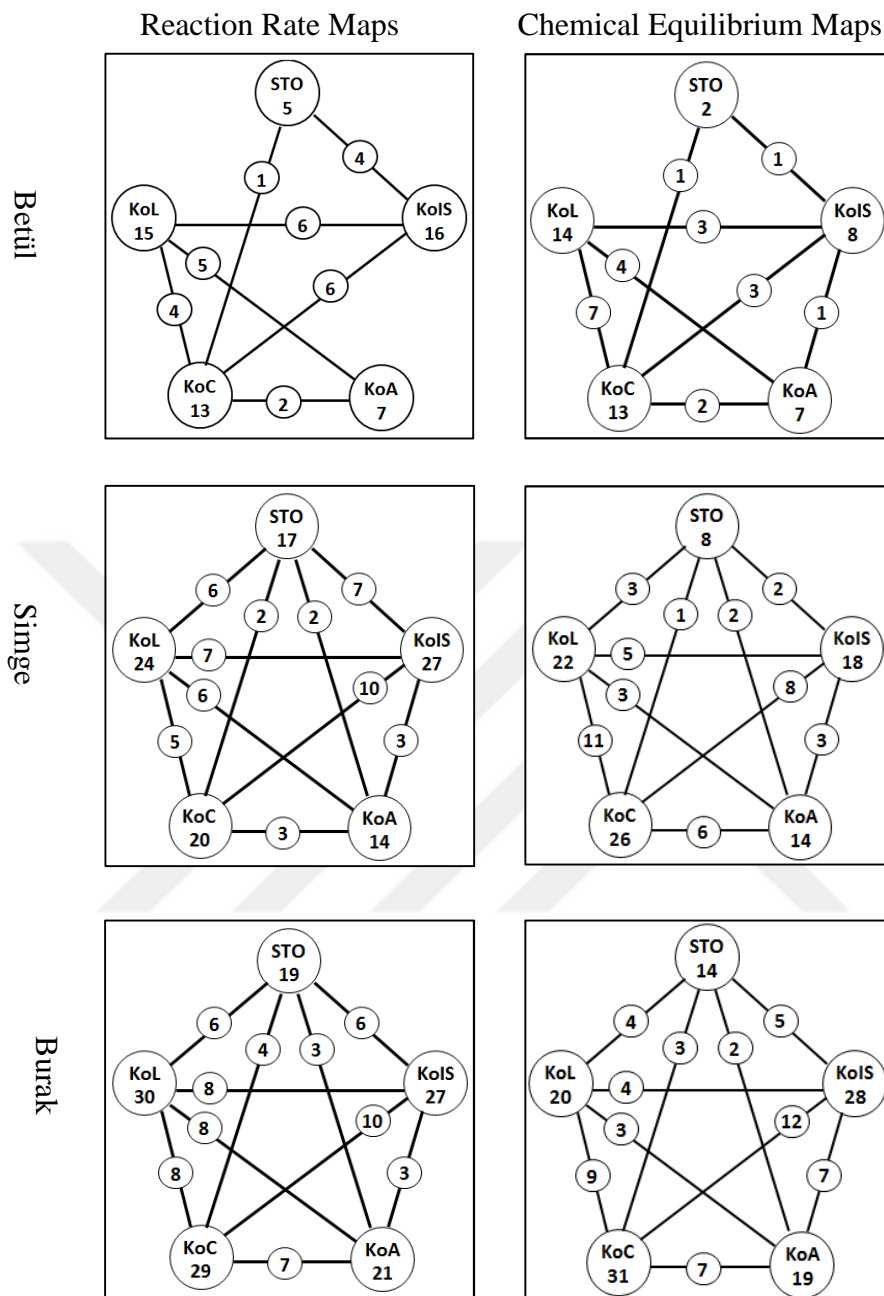

**Figure 4.1** PCK Maps

STO: Science teaching orientations, KoC: Knowledge of curriculum, KoL: Knowledge of Learner, KoIS: Knowledge of instructional strategies, KoA: Knowledge of assessment

**Table 4.1** Nine assertions regarding the interaction among PCK components

---

<b>Assertions regarding the interaction among PCK components</b>
<ol style="list-style-type: none"><li>1. The novice teacher's orientations towards science, in contrast to the experienced teachers, were much broad and non-specific, which impeded the connections among the components,</li><li>2. The integration of the PCK components was idiosyncratic and topic specific,</li><li>3. The novice teacher's PCK maps were fragmented while the experienced teachers' PCK maps were integrated,</li><li>4. Knowledge of learner, knowledge of curriculum and knowledge of instructional strategies were central in the interplays of all teacher maps,</li><li>5. The novice and experienced teachers displayed different levels of complexity in their interactions among PCK components,</li><li>6. The experienced teachers had much more two-way interactions among PCK components than the novice teacher,</li><li>7. The experienced teachers were more successful in translating their knowledge into practice in terms of the integration among PCK components than the novice teacher,</li><li>8. Teacher self-efficacy appeared to play a role in their use of PCK components and constructing of interactions among them,</li><li>9. All teachers taught the same topics with similar lesson plans and same instructional materials; however, they differed in terms of how effectively they connect the PCK components.</li></ol>

---

**4.1. The novice teacher's orientations towards science, in contrast to the experienced teachers, were much broad and non-specific, which impeded the connections among the components**

To gain a better understanding of the interactions, this study includes an analysis of the participants' science teaching orientations because it is known that it is an overarching component of PCK and influences the other PCK components (Grossman, 1990). To elicit the participants' science teaching orientations, data were collected through card-sorting task, classroom observations, and weekly post-interviews about instructions. First, the results of card-sorting task conducted before the observations of the instructions are displayed in Table 4.2. This table describes the teachers' science teaching orientations based on three categories: representative, not representative and unsure. For instance, activity-driven, discovery, conceptual

change, process, guided-inquiry were among the science teaching orientations chosen for representative category. The experienced teachers selected didactic, history of science and high stakes university entrance exam for not representative category, while the novice teacher did not select anything for that category. Project-based science, science-technology-society, terminology were among the science teaching orientations chosen for unsure category.

**Table 4.2** Teachers' science teaching orientations derived from card-sorting task before their instructions

<b>Teacher</b> <b>Scenarios</b>	<b>Burak</b>	<b>Simge</b>	<b>Betül</b>
<b>Representative</b>	Activity-driven Discovery Conceptual Change Process Academic-rigor	Activity-driven Discovery Conceptual Change Guided inquiry Process	Activity-driven Discovery Guided inquiry Project-based science Curriculum goal: Terminology
<b>Not representative</b>	Didactic Curriculum goal: History of science High stakes university entrance exam	Didactic Academic-rigor Curriculum goal: History of science High stakes university entrance exam	Not been selected
<b>Unsure</b>	Guided inquiry Curriculum goal: Terminology Curriculum goal: STS Project-based science	Curriculum goal: Terminology Curriculum goal: STS Project-based science	Didactic Conceptual Change Academic-rigor Process Curriculum goal: History of science High stakes university entrance exam Curriculum goal: STS

On the other hand, during classroom observations and post-interviews about the instructions, I realized several conflicts between teachers' science teaching orientations elicited during card-sorting task (called as ideal orientations) and real classroom practice. In other words, the information elicited from the card-sorting task was not consistent with the observations of the teachers' instructions and post-interviews about their instructions. Therefore, I also tried to elicit their observed orientations based on long-observation period and post-interviews about the instructions as shown in Table 4.3. This table describes the teachers' central (e.g., didactic) and peripheral goals (e.g., activity-driven).

**Table 4.3** Teachers' science teaching orientations: central and peripheral goals from long-observation period and post-interviews about the instructions

<b>Teachers</b>	<b>Central goals</b>	<b>Peripheral goals</b>
<b>Burak</b>	To relate chemistry to daily life (Everyday coping) To provide necessary knowledge to learners (Didactic) To develop conceptual understanding of chemistry (Conceptual change) To develop science-process skills (Process)	To prepare learners to high stakes university entrance exam To make learners active with materials and hands-on experiences (Activity-driven) To represent chemistry with difficult problems and activities (Academic-rigor)
<b>Simge</b>	To provide necessary knowledge to learners (Didactic) To develop conceptual understanding of chemistry (Conceptual change)	To relate chemistry to daily life (Everyday coping) To prepare learners to high stakes university entrance exam To make learners active with materials and hands-on experiences (Activity-driven) To develop science-process skills (Process)
<b>Betül</b>	To provide necessary knowledge to learners (Didactic)	To make learners active with materials and hands-on experiences (Activity-driven) To develop science-process skills (Process)

When I compared the tables 4.2 and 4.3, there were some differences between all participants' ideal and observed orientations. A close analysis of these tables revealed that there were much more differences between the novice teacher's ideal and observed orientations than that of experienced teachers.

According to the card-sorting task conducted before the teaching sessions, the novice teacher, Betül, chose the scenarios reflecting discovery, guided-inquiry, activity-driven, project-based science and curriculum goal: terminology for representative category. During implementing the card-sorting task, she frequently emphasized that one of her central goals was to *provide opportunities for students on their own to discover targeted science concepts (discovery)*. The scenario reflecting discovery was that

**Scenario reflecting discovery science teaching orientation:** As a chemistry teacher, you decide the best way to teach how rate of a reaction changes in time is to let students discover the relation between time and rate of reaction on their own.

In the pre-interview, she also stated that everyday coping and guided inquiry were also her essential science teaching orientations. However, she could not reflect her decisions on her teaching sessions that I observed. Betül selected the scenario reflecting didactic orientation for unsure category; however, it was observed that her teaching was primarily based on lecturing. She presented information to students didactically in most of her instructions. Her science teaching orientations was dominated by the view that teaching as telling and learning as listening. The scenario reflecting didactic was that:

**Scenario reflecting didactic science teaching orientation:** As a chemistry teacher, you decide the best way to teach the difference between instantaneous and average rate is to use lecturing and write the formulas of instantaneous and average rate on the blackboard.

During post-interviews in combination with classroom observations, I realized that she only held didactic orientation as a central goal and activity-driven and process orientations as peripheral goals. These discrepancies imply that the novice teacher's

orientations towards science were vague. During the post-interviews, I asked about the reasons of these discrepancies. She mentioned that loaded chemistry curriculum and her lack of teaching experience influenced her instructional decisions. This view is reflected in the interview excerpt below:

The first reason is that chemistry curriculum is too loaded; therefore, I have to focus only on covering all the topics on time. The second reason is teaching experience. Actually, I would prefer to teach my lessons based on discovery and inquiry; however, I could not. Giving students responsibility to state hypothesis, define variables, develop procedures, justify explanations as well as guiding students require teaching experience. (Betül, weekly post-interview, reaction rate)

This ambiguity related to her orientations influenced her interactions between science teaching orientations and the other PCK components. When I analyzed Betül's PCK maps, I could easily observe that it was the orientation component with which she constructed the least of links. In her PCK maps for both topics, science teaching orientation did not have any link with knowledge of assessment and learner components. In order to address students' misconceptions and difficulties, she usually warned them and re-explained the confusing parts without utilizing an additional instructional strategies or materials. Moreover, she did not check her students' understanding after her explanations. In the weekly post-interview, Betül answered my questions as follows:

R: Which difficulties did your students have while teaching reaction rate?

B: They had difficulties in expressing reaction rate both in terms of rate of decomposition and formation, and equating these two rates.

R: Before the instruction, were you aware that the students might have these difficulties or did you realize them while teaching the topic?

B: I had predicted.

R: How did you overcome these difficulties?

B: Because I thought that they might have these difficulties on expressing reaction rate, I warned them about possible difficulties that they might face.

In terms of peripheral goals, one of the goals of the novice teacher (Betül) was to activity-driven which reflects an instruction as “*provide students to participate in hands-on activities used for verification or discovery*”.

**Scenario reflecting activity-driven science teaching orientation:** As a chemistry teacher, you decide the best way to teach chemical equilibrium topic is to have students do laboratory activities.

In order to achieve this goal, she sometimes used laboratory works. For instance, after teaching factors affecting reaction rate, she let her students to do cook-book experiments related to the factors. She provided laboratory procedure step-by-step that the students had to follow. She also told students what data to gather and what results to expect. It was observed that laboratory activities were solely used for verification, since she always had students complete the cookbook lab. As a result, her instructions were mainly traditional, and her science teaching orientation was non-specific and didactic in nature which shaped her instructional decisions and how to implement them. In other words, her non-specific and didactic orientation filtered her instructional decisions.

Similar to Betül, during the card-sorting task, Burak (experienced teacher) stated that discovery was one of his central goals, and Simge (experienced teacher) stated that discovery and guided-inquiry were among of her central goals. However, they could not reflect these decisions on their teaching sessions that I observed. Although Burak and Simge selected the scenario reflecting didactic orientation for not representative category, it was observed that their teaching was primarily based on lecturing. During the post-interviews, I asked about the reasons of these differences. They stated that loaded chemistry curriculum and high stakes testing influenced their instructional decisions and impeded their ideal orientations. The experienced teachers primarily focused on transmitting new terms and concepts to students; however, they also gained much more additional goals than did the novice teacher. For instance, one of the central goals of these experienced teachers was to develop conceptual understanding of chemistry concepts (conceptual change).

**Scenario reflecting conceptual change science teaching orientation:** As a chemistry teacher, you decide the best way to teach the relation between the activation energy and enthalpy of reaction is to make out their misconceptions by asking questions and then try to address their misconceptions.

Additionally, relating chemistry to daily life (everyday coping) and developing science process skills (process) were central goals for Burak, while they were peripheral goals for Simge. In addition, Burak held peripheral goals such as activity-driven, academic-rigor and preparing learners to high stakes university entrance exam. Simge also held peripheral goals such as activity-driven and preparing learners to high stakes university entrance exam.

Different from the novice teacher, the experienced teachers utilized their distinctive science teaching orientations and the remaining PCK components intensively. Although their teaching was generally based on lecturing, they enriched their instructions with analogies, demonstrations, animations, experiments, daily life examples and simulations than did the novice teacher. They used these instructional strategies to demonstrate the relationship between specific concepts and phenomena. Particularly Burak, the most experienced teacher, used a variety of instructional strategies and materials in order to eliminate his students' misconceptions. He frequently stated in light of his teaching experience, he was familiar with common students' difficulties and misconceptions in each topic; therefore, he handled them with an additional instructional strategy effectively. As an example, he was aware about students' difficulties in understanding the difference between average and instantaneous reaction rate. With a didactic science teaching orientation view, he taught the difference between these two concepts whereby lectures supported an analogy and questions in order to help his students. Burak was able to integrate his knowledge of instructional strategy and knowledge of learner in light of his science teaching orientation:

Assume that, you are travelling from city A to city B. The distance between these two cities is 450 km and it takes approximately 5 hours. What can you say about your average velocity? [Students answered] The answer was 90

km/h. Then, do you drive with the same velocity, 90 km/h? [Students answered] No, it changes. So, are the average and instantaneous velocity same or not? [Students answered] No. (Burak, field notes, reaction rate)

In another example, Burak's process science teaching orientation shaped the way about how to overcome students' misconceptions. In other words, his science teaching orientation influenced his knowledge of learner and knowledge of instructional strategies. In the following interview excerpt, Burak stated that

I was aware of my students' misconception that for an endothermic reaction, as the temperature is raised, only rate of forward reaction increases. When I asked the reason, the students stated that according to the Le Chatelier's principle, for an endothermic reaction, an increase in temperature increases only rate of forward reaction. Drawing graph is important at this point. To overcome their misconception, I wanted them to draw graphs (concentration vs. reaction path and reaction rate vs. reaction path) and interpreted them. They tried to draw these graphs. Then, I checked their drawings and wanted them to explain their graphs (Burak, weekly post-interview, chemical equilibrium).

Similarly, in light of her process science teaching orientation, Simge encouraged her students to draw graphs and solve questions by using graphs for some concepts and interpreted them in order to help students develop science process skills. For instance, in the weekly post-interview about the instructions, she stated that

The students can solve verbal questions. For instance, they can calculate the enthalpy of reaction by using the formula (i.e., the energy difference between forward and reverse reaction) when the data are given verbally. However, when I write the same data on a graph, they cannot solve it [knowledge of areas of students' difficulties]. In addition, I expect them to draw the graph of enthalpy of reaction vs. reaction path, and the graph of number of particles vs. kinetic energy. Therefore, in order for students to visualize the data, I want students to draw graphs and interpret them [knowledge of topic-specific

representations]. I believe that they understand better (Simge, weekly post-interview, reaction rate).

The excerpt above indicated that Simge's process science teaching orientation informed her knowledge of learner and instructional strategies components.

As seen in these examples, the novice teacher's orientations towards science were broad, which impeded the connections among the components whereas the experienced teachers, used their distinctive science teaching orientations and the remaining PCK components intensively. Therefore, they had much more connections and coherence among all components, regardless the topic, than that of the novice teacher.

#### **4.2. The integration of the PCK components was idiosyncratic and topic specific**

As explained in the methodology part, teachers taught the same topics with the same instructional materials and similar lesson plans; however, their PCK Maps differed from each other. Additionally, each teacher's PCK Map showed variances for the two topics. These findings might be resulted from the idiosyncratic nature and topic-specificity of the integrations among the PCK components as exemplified below.

First of all, all teachers had more interplay in reaction rate topic than equilibrium topic in total. In addition, the experienced teachers (Simge and Burak) demonstrated more coherently structured PCK Maps for both topics than the novice teacher (Betül). For instance, in reaction rate topic, Burak and Simge integrated the PCK components 63 and 51 times in total whereas Betül integrated only 28 times. In chemical equilibrium topic, Burak and Simge connected the components 56 and 44 times in total respectively, whereas Betül integrated only 22 times. For the frequency of total interactions among PCK components for reaction rate and chemical equilibrium, see Table 4.4.

**Table 4.4** The frequency of total interactions among PCK components for reaction rate and chemical equilibrium

<b>Teacher \ Topic</b>	<b>Reaction Rate</b>	<b>Chemical Equilibrium</b>
<b>Burak</b>	63	56
<b>Simge</b>	51	44
<b>Betül</b>	28	22

Additionally, in reaction rate topic, the most experienced teacher, Burak connected knowledge of learner, instructional strategies, curriculum, assessment and orientation components 30, 27, 29, 21 and 19 times, respectively. In chemical equilibrium topic, Burak connected the same components, 20, 28, 31, 19, and 14 times, respectively. Simge integrated knowledge of learner, instructional strategies, curriculum, assessment and orientation components 24, 27, 20, 14, and 17 times, respectively, in reaction rate topic. Simge integrated the same components 22, 18, 26, 14, and eight times, respectively, in chemical equilibrium topic. On the other hand, the least experienced teacher, Betül, integrated knowledge of learner, instructional strategies, curriculum, assessment and orientation components 15, 16, 13, seven, and five times, respectively, in reaction rate topic. Betül integrated the same components 14, eight, 13, seven, and two times, respectively, in chemical equilibrium topic. Throughout the post interviews, Betül often confessed that teaching chemical equilibrium topic was more challenging than reaction rate topic. This view is reflected in the interview excerpt below:

I taught the “concentrations vs. time and rate vs. time graphs when a change is made to a system at equilibrium” for the first time in chemical equilibrium topic. Actually, it was difficult for me. I was not sure whether I had a misunderstanding or not. Therefore, before the instruction, I observed both Burak and Simge’s teaching of these graphs. In addition, in order to learn the graphs, I tried to draw these graphs many times before the instruction (Betül, weekly post-interview, chemical equilibrium).

Moreover, Betül expressed that because her students had many difficulties in understanding the concepts in chemical equilibrium, teaching this topic was difficult for her as she described below:

As a matter of fact, [in chemical equilibrium topic], I knew what to teach them step by step. However, because students had difficulties in understanding of heterogeneous and homogeneous equilibrium, and the reasons of omitting concentration terms for solids and liquids while writing heterogeneous equilibrium, teaching chemical equilibrium was difficult for me (Betül, weekly post-interview, chemical equilibrium).

Another example for idiosyncratic and topic-specific nature of interplays was that the experienced teachers were able to utilize and relate all components whereas the novice teacher did not make all connections among PCK components. As an example, in Betül's teaching chemical equilibrium, no integration was observed between her science teaching orientations and knowledge of learner as well as science teaching orientations and knowledge of assessment components. Conversely, the missing interactions in her reaction rate PCK Map were between science teaching orientations and knowledge of learner, science teaching orientations and knowledge of assessment, and knowledge of assessment and instructional strategies components. When analyzed the PCK maps of Betül, it could be easily seen that science teaching orientation played an active role in missing parts, because Betül's science teaching orientation was so broad and non-specific that was discussed in previous section.

The most and the least frequent interactions among PCK components showed differences between the topics for the same teacher which indicated the idiosyncratic nature and topic-specific nature of the interplays (Table 4.5). For instance, Burak's reaction rate PCK map revealed that the most frequent interaction was between knowledge of curriculum and instructional strategies (10 times), and less frequent interactions were between science teaching orientations and assessment components (three times) and between instructional strategies and assessment components (three times). In his chemical equilibrium map, the most frequent interaction was between knowledge of curriculum and instructional strategies (12 times) and less frequent

interactions were between science teaching orientations and assessment components (two times). Simge's reaction rate PCK map showed that the most frequent interaction was between knowledge of curriculum and instructional strategies components (10 times). The less frequent interactions were between science teaching orientations and curriculum components (two times) and between science teaching orientations and assessment components (two times). For teaching chemical equilibrium, Simge made more interactions between knowledge of learner and curriculum components (11 times), and less interaction between science teaching orientations and knowledge of curriculum components (one time). In Betül's reaction rate PCK map, the most frequent interactions were observed between knowledge of learner and instructional strategies (six times), and between knowledge of curriculum and instructional strategies (six times). In her chemical equilibrium PCK map, the interaction between knowledge of learner and curriculum components (seven times) was the most frequent one. In Betül's rate and equilibrium PCK maps, she did not connect science teaching orientations with knowledge of learner and assessment components. In addition, in her reaction rate PCK map, no interplay was observed between knowledge of assessment and instructional strategies components.

**Table 4.5** The most and least frequent interactions in the participants' PCK Map for reaction rate and chemical equilibrium

Teacher	The most frequent interactions		The least frequent interactions	
	Reaction Rate	Chemical Equilibrium	Reaction Rate	Chemical Equilibrium
<b>Burak</b>	KoC- KoIS (10)	KoC- KoIS (12)	STO-KoA (3) KoA-KoIS (3)	STO-KoA (2)
<b>Simge</b>	KoC- KoIS (10)	KoL- KoC (11)	STO-KoC (2) STO-KoA (2)	STO-KoC (1)
<b>Betül</b>	KoC- KoIS (6) KoL- KoIS (6)	KoL- KoC (7)	STO-KoL (0) STO-KoA (0) KoA-KoIS (0)	STO-KoL (0) STO-KoA (0)

STO: Science teaching orientations, KoC: Knowledge of curriculum, KoL: Knowledge of learner, KoIS: Knowledge of instructional strategies, KoA: Knowledge of assessment.

One further example of the idiosyncratic and topic-specific nature of interplays was the differences in both number and kinds of interactions among sub-components of PCK for each teacher in different topics. Burak could make much more different types of interactions among sub-components of PCK than the other teachers. In his reaction rate PCK map, Burak had 36 types of interactions among the sub-components, and in equilibrium map, he had 31 types of interactions. When we compared Burak's PCK map with the other two teachers' maps in terms of interactions among sub-components, it appeared that Burak had 14 types of interactions in reaction rate and 10 types of interactions in equilibrium topic which the other two teachers did not construct. As an example, solely Burak could connect everyday coping [subcomponent of science teaching orientations] with teachers' knowledge of goals and objectives [subcomponent of knowledge of curriculum] in chemical equilibrium topic. He always tried to teach chemical equilibrium concepts by relating these concepts to daily life. In addition, except Burak, the other two teachers could not link knowledge of areas of students' misconceptions [sub-

component of knowledge of learner] with knowledge of methods of assessment [sub-component of knowledge of assessment] in rate of reaction. The following quote reflects this interaction in which his knowledge of assessment informed his knowledge of learner:

I prepared a quiz [knowledge of assessment] in order to test their understanding of reaction mechanism. According to the results of the quiz, I realized that some of the students were still confusing the energy of activated complex and enthalpy of reaction [knowledge of learner] (Burak, weekly post-interview, reaction rate).

Simge had 27 types of interactions among the sub-components of PCK in reaction rate topic, and she had 24 types of interactions in chemical equilibrium topic. When we compared Simge's PCK map with the other two teachers' maps in terms of interactions among sub-components, it appeared that Simge had seven types of interactions in reaction rate and one type of interactions in equilibrium topic which the other two teachers did not construct. For example, only Simge could link process science teaching orientation [subcomponent of science teaching orientations] with what to assess component [subcomponent of knowledge of assessment] in chemical equilibrium topic. In the interviews, she always emphasized that she wanted her students to be able to draw graphs and interpret them for chemistry concepts. In light of her view, in the exam she asked a question which was:

The Haber process enables the large-scale production of ammonia needed to make fertilizers. The equation for the Haber process is given below:

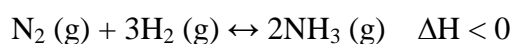

Draw the concentration vs. reaction pathway and rate vs. reaction pathway graphs for each case: a) Adding  $\text{N}_2(\text{g})$  and b) increasing temperature.

When I asked the reason for asking this question in the weekly post-interview, she told that she wanted her students to draw graphs and interpret them in order to develop their science process skills. In the example above, her process science teaching orientation informed what to assess sub-component. Another example from reaction rate topic, only Simge integrated knowledge of areas of students'

misconceptions [sub-component of knowledge of learner] with knowledge of topic-specific representations [sub-component of knowledge of instructional strategies] in topic. This interaction was recorded as:

Researcher: Why did you prefer to use an animation related to collisions of molecules with proper and improper orientations?

Simge: Some students have difficulties in understanding the collisions of molecules with proper orientations at sub-microscopic level. Specifically, they thought that every collision between reactant particles lead to products [knowledge of areas of students' misconceptions]. In order to help them, I used an animation [knowledge of instructional strategies] in order to show collisions of molecules with proper and improper orientations at submicroscopic level (Simge, weekly post-interview, reaction rate).

On the other hand, in reaction rate topic, Betül had only 16 types of interactions among sub-components, and in equilibrium topic, she had 15 types of interactions. When we compared her PCK maps with the other teachers' maps in terms of interactions among sub-components, she had only one type of interaction in chemical equilibrium topic which the other teachers did not have. She integrated knowledge of areas of students' misconceptions [sub-component of knowledge of learner] with knowledge of topic-specific activities [sub-component of knowledge of instructional strategies] in chemical equilibrium topic. She explained this relationship in the following excerpt:

Researcher: Why did you prefer to use the simulation about the equilibrium reaction of dinitrogen tetroxide ( $N_2O_4$ )?

Betül: Even though chemical reactions can reach equilibrium from both sides, the students thought that equilibrium may only be obtained when only reactants are added to the system [knowledge of learner]. Actually, when a system at equilibrium undergoes a change in moles of reactant or product or mixture of them, the system will react in order to attain equilibrium (Betül, weekly post-interview, reaction rate).

All these findings indicated the idiosyncratic nature and topic-specificity of the integrations among the PCK components.

#### **4.3. The novice teacher's PCK maps were fragmented while the experienced teachers' PCK maps were integrated**

The experienced teachers' PCK components were not only more comprehensive than those of the novice teacher but also differently formed in more highly interacted modes. The experienced teachers were able to utilize and relate all PCK components whereas the novice teacher did not make all connections. Therefore, it can be concluded that whereas the novice teacher's PCK maps were fragmented, the experienced teachers' PCK maps were integrated.

The PCK maps indicated that the novice teacher rarely integrated science teaching orientations and knowledge of assessment into her PCK. As an example, in Betül's teaching of both reaction rate and chemical equilibrium topics, integration was neither observed between orientations and learner components nor between orientations and assessment components. Betül could make limited connections of science teaching orientation with only curriculum and instructional strategies components for both topics. In reaction rate topic, she could link orientation with curriculum one time and with instructional strategies four times. She linked orientation with curriculum and instructional strategies only one time in chemical equilibrium topic. Since Betül's science teaching orientation was so broad and non-specific, this situation might decrease the interaction between science teaching orientation and other PCK components. As I explained before, different from the novice teacher, the experienced teachers used their distinctive science teaching orientations and the remaining PCK components coherently. Additionally, the novice teacher's limited topic-specific knowledge about learner, instructional strategies, and assessment components might also prevent the interactions among the components. For instance, in her teaching of reaction rate, she could not link knowledge of assessment with knowledge of instructional strategies and science teaching orientations. The only connections were observed between assessment and

curriculum components (two times) and between assessment and learner components (five times) in reaction rate topic. In her teaching chemical equilibrium, she could link knowledge of assessment with curriculum (two times), learner (four times) and instructional strategies (one time), whereas she could not link assessment with orientation component. Generally, when compared to experienced teachers, the novice teacher had a poor PCK which may prevent the interactions among the components. During the interviews, she frequently reflected that she did not have enough experience for teaching these two topics; therefore she did not have enough knowledge, for example, about difficulties and misconceptions that students had. She was aware that students might have difficulties and misconceptions; however, she was not familiar with common students' difficulties and misconceptions in reaction rate and chemical equilibrium topics. This view is reflected in the interview excerpt below:

Researcher: You will teach reaction rate topic for the first time. Do you think teaching this topic is difficult for you or not?

Betül: It may be difficult for me in terms of students' misconceptions because I only know few student misconceptions in reaction rate from the articles that I read. However, I do not know what difficulties students have and what kinds of questions they can ask about the topic while teaching (Betül, pre-interview in the form of CoRe, reaction rate).

Moreover, she stated that when she faced a difficulty in the classroom, she did not know the way to address it. She only warned her students and re-explained the points that the students had difficulties. Her knowledge of learner was not always connected to their knowledge of instructional strategies. This aspect was reflected in her PCK Map in chemical equilibrium topic. In her chemical equilibrium map, knowledge of learner was identified 14 times, but only three of the 14 were connected with knowledge of instructional strategies. She did not endeavor to help them better understand it. An excerpt from weekly post-interview reflects this situation:

The students had difficulties in understanding the difference between equilibrium constant ( $K_c$ ) and reaction quotient ( $Q_c$ ). They frequently asked

why we wrote reaction quotient as equilibrium constant, and the difference between them. In addition, the relation between molar concentration of reactants and products when the mixture goes to equilibrium are another difficult point for them. In order to overcome their difficulties, I stressed that point again and again (Betül, weekly post-interview, chemical equilibrium).

Different from the novice teacher, the experienced teachers could utilize all PCK components and integrate them coherently. It could be observed in their teaching sessions that all PCK components informed each other many times; this was not the case for the novice teacher. For example, Simge, in contrast to the novice teacher, had enough knowledge about the learner and instructional strategies; therefore, she easily connected them. When students had a misconception, she could easily overcome it. The relationship between these two components is illustrated in the following quote from weekly post-interview:

Researcher: You used an illustration of quicklime (calcium oxide). Why did you prefer to use this illustration?

Simge: I used it for heterogeneous equilibrium. The students had difficulties in understanding why the concentration of [pure] solids or liquids is constant [knowledge of learner]. When I explained the pressure of the carbon dioxide does not depend on the amount of  $\text{CaCO}_3$  and  $\text{CaO}$ , it does not revive in the students' mind. In order to show that equilibrium and the pressure of the carbon dioxide does not affected by amount of these substances, I used that illustration (see Figure 4.2) [knowledge of instructional strategies] and explained it in detail (Simge, weekly post-interview, chemical equilibrium).

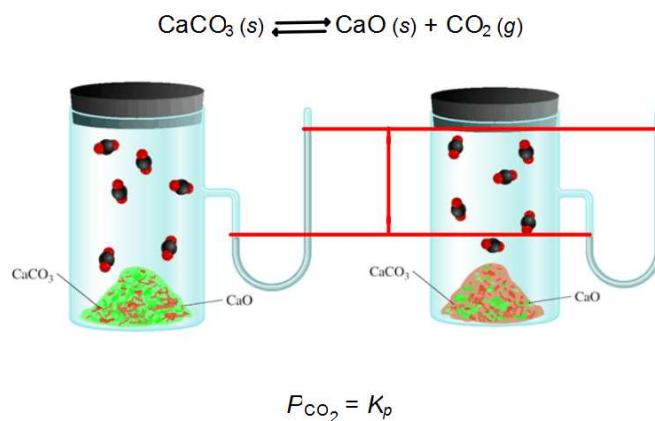

$P_{\text{CO}_2}$  does not depend on the amount of  $\text{CaCO}_3$  or  $\text{CaO}$

**Figure 4.2** Quicklime (calcium oxide).

Similarly, Burak easily identified his students' learning difficulties or misconception and attempted to tailor his instructional strategies to overcome their learning difficulties or misconception in both topics. In other words, his knowledge of learner was frequently connected to his knowledge of instructional strategies. For instance, during the instruction, he drew the following graph on the board (see Figure 4.3) and asked the students:

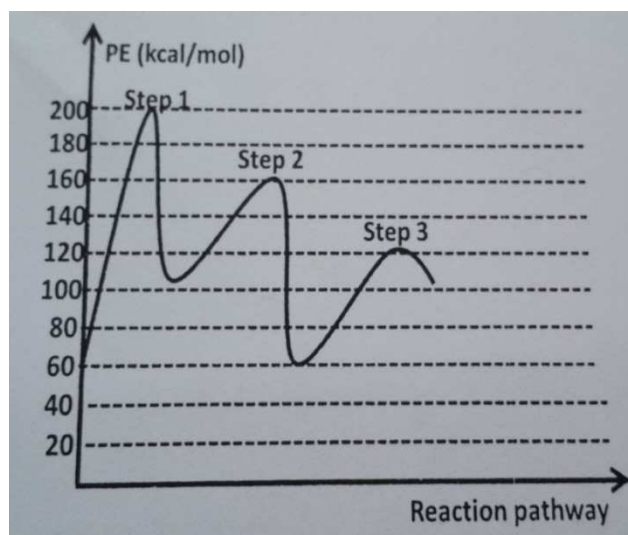

**Figure 4.3** Potential energy vs reaction pathway graph

Burak: Which step is the rate determining step?

Student 1: We cannot know this.

Student 2: The middle or the left one.

Burak: Please, come to the board and calculate the activation energies.

Student 2: I do not know how to calculate it [activation energy]. (Burak, observation of the instructions, reaction rate)

During the instruction, some students did not analyze the energy and reaction pathway graph, and which step the rate-determining step in the reaction mechanism is. Especially, they did not understand the relation between slow step and activation energy. Then, Burak used an analogy that was:

There are two barriers, one of them is low and the other one is high. Passing over the high barrier needs much more energy than passing over the low barrier. The number of people passing over the low barrier per unit time is much more than that of high barrier. Therefore, for the same number of people, passing over the high barrier will be slower than the low barrier (Burak, observation of the instruction, reaction rate).

Then, he made a connection between this analogy and the relation between slow step and activation energy in a reaction mechanism in order to resolve the students' difficulties. In the weekly post-interview, I asked the reason for using this analogy. He stated that "The students could not understand the relation between activation and rate-determining step [knowledge of learner]. Therefore, I used that analogy [knowledge of instructional strategies] in order to make it [the relation between activation and rate-determining step] much more understandable" (Burak, weekly post-interview, reaction rate).

As a result, all these examples indicated that the novice teacher's weak PCK components prevented her from establishing powerful link among them, compared to the experienced teachers. Therefore, the novice teacher's PCK maps were fragmented while the experienced teachers' PCK maps were integrated.

#### **4.4. Knowledge of learner, knowledge of curriculum and knowledge of instructional strategies were central in the interplays of all teacher maps**

The PCK maps indicated that the most central components in all teachers' teaching were knowledge of learner, curriculum and instructional strategies components. In other words, all teachers frequently integrated knowledge of learner, curriculum and instructional strategies components into their PCK. In particular, Burak integrated knowledge of learner, curriculum and instructional strategies components 30, 29, and 27 times, respectively in reaction rate topic, while he integrated the same components 20, 31, and 28 times in equilibrium topic, respectively. Similarly, in reaction rate topic, Simge connected knowledge of learner, curriculum and instructional strategies components 24, 20, and 27 times respectively, whereas, in her teaching of chemical equilibrium, she linked the same components 22, 26, and 18 times, respectively. These components were also central in the novice teacher's instruction but not as much as experienced teachers' instructions. In Betül's teaching reaction rate, knowledge of learner (15 times), curriculum (13 times) and instructional strategies (16 times) were the most central components. In her teaching chemical equilibrium topic, knowledge of learner (14 times) and curriculum (13 times) were the most central components. In this regard, I concluded that curriculum, learner and instructional strategies components played an influential role in shaping their PCK.

Furthermore, the connections among those three components often appeared in the teachers' instruction. The more interactions among PCK components indicated its strength. Therefore, it can be inferred that the interactions among those three components were the strongest among all interactions in the PCK maps. For instance, in both Burak and Simge's teaching chemical equilibrium, a strong connection was observed between knowledge of curriculum and knowledge of instructional strategies (Burak: 12; Simge: 8). The close analysis among sub-components of PCK showed that the experienced teachers' knowledge about goals and objectives to learn reaction rate and chemical equilibrium topics [knowledge of curriculum] most frequently informed their knowledge of topic specific representations [knowledge of

instructional strategies]. For instance, Simge draw concentration vs. time and rate vs. time graphs [knowledge of instructional strategies] in order to teach Le Chatelier's principle [knowledge of curriculum], which states that when a system in chemical equilibrium is disturbed by a change of a concentration, temperature, or pressure, the system shifts in equilibrium composition in a way inclining to respond the change (observations of instructions, chemical equilibrium). Then, I asked the reason for using that graphs in the post-interviews, she stated that:

They [the students] saw the effects of the changes on the equilibrium much more clearly on the graphs. Instead of explaining that the system shifts right or left to respond the change, I tried to explain them with graphs. If they can draw the graphs properly, they do not definitely make a mistake. Therefore, I try to explain it [Le Chatelier's principle] in this way [graphs] (Simge, weekly post-interviews, chemical equilibrium).

Similarly, Burak frequently linked these two sub-components (i.e., knowledge about goals and objectives, and knowledge of topic specific representations). For example, he used the following analogy in order to explain dynamic equilibrium, which includes a forward reaction, in which reactants are converted to products, and a reverse reaction, in which products are converted to original reactants, and the rate of these two reactions are equal (observation of instructions). When it was asked during the weekly post-interview; he stated:

In order to explain dynamic equilibrium [knowledge about goals and objectives], I used an analogy which was: "assume that there are 12 students in this class. Among these students, 11 of them are sitting and one of them is standing. While the student who is standing will sit, at the same time, one of the students who is sitting will stand. The process is going on. Anyone who is looking this class from outside thinks that there is no change in the number of sitting students [knowledge of topic specific representations] (Burak, weekly post-interview, chemical equilibrium).

Then, he connected this analogy to the chemical dynamic equilibrium with the decomposition of dinitrogen tetroxide ( $N_2O_4$ ).

Moreover, among all teachers, Burak connected reaction rate and chemical equilibrium much more frequently both to the topics taught in previous years (e.g., gases, energy and bonding, etc.) and to topics taught within the same grade (e.g., enthalpy, endothermic reaction, etc.) while planning and enacting their teachings than the other two teachers. For instance, after teaching Le Chatelier's principle, he wanted his students to draw concentration vs. time and rate vs. time graphs of formation of ammonia reaction when one of reactants is added and removed from the system. After taking the students' drawings and ideas, he drew the graphs on the board [knowledge of instructional strategies] by relating the topic to a previous one (i.e., reaction rate) [knowledge of curriculum]. In this example, he used his knowledge of curriculum (i.e., horizontal relations of the topics in the same grade) while drawing graphs [knowledge of instructional strategies]. Additionally, he wanted the students to draw concentration vs. time and rate vs. time graphs of the formation of sulfur trioxide from the oxidation of sulfur dioxide when volume of the system is increased and decreased. After taking the students' drawings and ideas, he drew the graphs on the board [knowledge of instructional strategies] by relating the topic to a previous one taught in previous year (i.e., calculation of molarity) [knowledge of curriculum] (Burak, field notes, chemical equilibrium). In this example, he utilized his knowledge of curriculum (i.e., vertical relations of the topics to the previous grade) while drawing graphs [knowledge of instructional strategies].

The novice teacher, Betül integrated mostly knowledge of learner with knowledge of curriculum seven times in her teaching chemical equilibrium. When I analyzed the interactions among sub-components of these two components, I realized that her knowledge of goals and objectives [knowledge of curriculum] most frequently informed her knowledge of areas of student difficulty [knowledge of learner]. To exemplify for this interaction, while explaining heterogeneous equilibrium and writing equilibrium-constant expression for a heterogeneous equilibrium [knowledge of curriculum], she took the students' difficulties in understanding the reason of omitting concentration terms for solids and liquids into

consideration [knowledge of learner] (Betül, observations of instructions, chemical equilibrium). This interaction was reflected in the interview excerpt below:

I predict that the student might have difficulties in writing equilibrium-constant expression for a heterogeneous equilibrium and the reason of omitting concentration terms for solids and liquids. Therefore, while explaining heterogeneous equilibrium, I tried to focus on their difficulties. Indeed, I can say that which concentration terms are omitted or not were difficult for them (Betül, weekly post-interview, chemical equilibrium).

On the other hand, none of the teachers bring their knowledge of subject-specific strategies (e.g., learning cycle, inquiry) into play while teaching both topics. Their teaching was generally based on lecturing; however, they enriched their instruction with topic specific activities and representations. Burak, the most experienced teacher, used much more frequently topic-specific activities (e.g., demonstrations, experiments, simulations) and topic-specific representations (e.g., drawing graphs, daily life examples, analogies) in his instructions than the other teachers (observations of instructions). For instance, he provided a lot of daily life examples such as comparing rate of burning of wood and oxidation of iron (observation of instructions, reaction rate). During the instruction, he asked:

Burak: Are the rate of burning of wood and oxidation of iron similar or not?

Student: No. One of them is fast and the other one is slow.

Burhan: Why one of them is slow and the other one is fast?

Student 1: It can be related to the energy.

Burak: Can it be?

Student 2: Yes. The necessary energies for starting the reactions are different from each other.

Burak: Yes, you are right. Have you heard anything about activation energy? [Some of the students had knowledge about it]. The necessary energies for activating them are different from each other. We will talk about it later (Burak, observation of the instructions, reaction rate).

Moreover, he asked several questions related to daily life in order to teach the effect of temperature on reaction rate. During the instruction, he asked:

Burak: Why do we put our foods into the freezer?

Student 1: In order for foods not to undergo spoilage.

Burak: Why do the foods undergo spoilage?

Student 2: Actually, the foods undergo spoilage in the freezer but it takes much more time.

Burak: Can we say that temperature have an effect on reaction rate?

Student 3: Yes. (Burak, observation of the instructions, reaction rate)

Moreover, Burak made several demonstrations. One of them was that a demonstration with hydrogen peroxide ( $H_2O_2$ ) [topic-specific activities] in order to teach the effect of catalyst on rate of reaction [knowledge of goals and objectives] (observation of instructions, reaction rate). This observation was reflected in the following excerpt:

He put hydrogen peroxide into a beaker and asked the students how I can decompose hydrogen peroxide. [Hydrogen peroxide is not a very stable compound; therefore, it is decomposes to water and oxygen. However, under normal conditions, the decomposition goes very slowly]. The students told that we can heat the solution. Then, he heated the solution. They observed bubbles. Burak created a discussion environment to understand the reason of this observation. After that, Burak asked the students what else we can do to increase its decomposition. One of the students told that we can use catalyst. Then, Burak put a piece of potassium iodide (KI) as a catalyst and they observed much more bubbles, because the reaction goes much more quickly. Again, Burak created a discussion environment to understand the reason of this observation (Burak, field notes, reaction rate).

In the weekly post-interview, I asked the reason of using that demonstration. He stated that “I always expected students to make an inference about the concept. Therefore, I prepared that demonstration to show the relationship between concept and that phenomenon.” (Burak, weekly post-interview, reaction rate)

#### 4.5. The novice and experienced teachers displayed different levels of complexity in their interactions among PCK components

When PCK segments from the teachers' instruction in both topics were examined and coded, I realized a variety of complexity in the interactions among the components. Some of the interactions were very simple that one PCK component connected the other one while some others were complicated including more than two different PCK components. In general, the interactions in Betül's teaching were so simple that one PCK component was related to the other one. For example, her knowledge of curriculum informed her knowledge of instructional strategies in reaction rate. In the weekly post-interview, she stated that it was instructive to draw a potential-energy diagram [knowledge of instructional strategies] in order to teach the activation energy associated with energy of the reactants and products, which is stated in the national chemistry curriculum [knowledge of curriculum]. Another example for simple interaction was observed in Betül's teaching of chemical equilibrium topic. In the example below, her knowledge of assessment informed her knowledge of learner:

Researcher: How did you evaluate your students' understanding?

Betül: I prepared an essay type exam [how to assess]. For example, there was a question related to the equilibrium reaction of sulfur dioxide ( $2\text{SO}_2(\text{g})+\text{O}_2(\text{g})\leftrightarrow 2\text{SO}_3(\text{g})$ ), which was represented by the figure below (Figure 4.4).

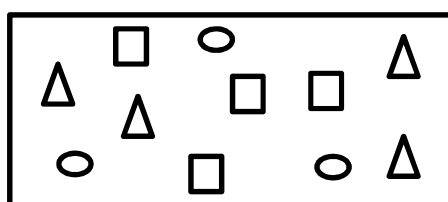

**Figure 4.4** A Representation for the equilibrium reaction of sulfur dioxide

In the figure,  $\text{SO}_2$  is represented by triangle,  $\text{SO}_3$  is represented by square, and  $\text{O}_2$  is represented by circle. The question was that draw how the above representation is changed when temperature and pressure is increased.

Betül: In general, my students had difficulties in solving this question. They tried to solve this question without taking the coefficient of molecules into consideration. They also thought that the reactant molecules had to be consumed in order to reach equilibrium [knowledge of learner]. This is a big misunderstanding that I realized, because in order for a system to shift in equilibrium composition, all molecules should be in the system (Betül, weekly post-interview, chemical equilibrium).

On the other hand, the experienced teachers interconnected several PCK components in most of their teaching segments. In general, Burak's teaching segments in reaction rate and chemical equilibrium topics had much more complicated interactions than the other two teachers. To illustrate, in the pre-interview, Burak stated

There was an objective in the 11<sup>th</sup> grade chemistry curriculum which read "to explain the effect of temperature on chemical equilibrium" [knowledge of curriculum]. In general, the students had difficulties in understanding the effect of temperature on chemical equilibrium for endothermic and exothermic reactions [knowledge of areas of students' difficulties]. In order to help them and make an evaluation, I will design an instruction in which students perform an experiment, collect and interpret data, and then draw a conclusion (knowledge of instructional strategies and knowledge of assessment) (Burak, pre-interview in the form of CoRe, chemical equilibrium).

Then, I observed that he made an instruction in which students made an experiment to observe the effect of temperature on chemical equilibrium. After the instruction, in the weekly post-interview about the instruction, he stated that the learners realized the effect of temperature on chemical equilibrium for endothermic and exothermic reactions during the experiment. He added that they also answered the questions

correctly in the experiment report. It appeared that in light of his process science teaching orientation, his knowledge of curriculum and students' difficulties informed his knowledge of instructional strategies as well as his knowledge of assessment.

Simge had both simple and complex interactions. Regarding simple interaction, for example, her knowledge of curriculum informed the use of knowledge of assessment. Indeed, the interaction between these components was simple that one PCK component informed the other one. For example, in her teaching rate of reaction, I observed that she conducted a pop-quiz. In the post-interview about the instructions, I asked her the reason why she used this pop-quiz. She stated that:

In order to evaluate my students' understanding of rate expression and calculation of rate and rate constant [knowledge of curriculum], I prepared a quiz [how to assess] and ask a question that was writing of rate expression of a reaction, and calculating rate and rate constant of that reaction [what to assess] (Simge, weekly post-interview, reaction rate).

The next example was related to complex interaction from her teaching chemical equilibrium. During teaching heterogeneous equilibrium, she tried to teach when a system in heterogeneous equilibrium is disturbed by a change (e.g., concentration) how the system shifts in equilibrium composition in a way tending to counteract the change. She wrote the following reaction on the board:

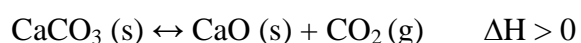

She asked her students:

Simge: How does the system shift when we add  $\text{CaCO}_3(\text{s})$ ?

Student 1: The system shifts right.

Simge: Any other idea?

Student 2: [The system] shifts right.

Simge: Please, remember how we wrote equilibrium constant expression for an heterogeneous equilibrium.

Student 3: The concentration the solids and liquids are not included in the [equilibrium constant] expression.

Simge: In an heterogeneous equilibrium, reactants and products can be in different phases. The concentration change in the solids and liquids is always constant. As we did for homogeneous equilibrium, let's draw concentration vs. time graph when we add  $\text{CaCO}_3(\text{s})$ . (Simge, observation of instructions, chemical equilibrium).

Then, she encouraged all students to draw this graph. She gave time to the students. When some of the students had difficulties in drawing graph, she help them to draw the graph and made necessary explanations. When I asked her the reason why she encouraged the students to draw graph, she stated:

While teaching heterogeneous equilibrium [knowledge of curriculum], as I expected, my students had difficulties in understanding when a system in heterogeneous equilibrium is disturbed by a change [of a concentration, temperature, or pressure, how the system shifts in equilibrium composition in a way inclining to respond the change] [knowledge of learner]. In order to address their difficulties, I oriented them to draw concentration vs. time graph when a change of a concentration, pressure, or temperature occurs. In my opinion, when they learn drawing this graph, they can understand this [heterogeneous equilibrium]. [Her process orientation informed her knowledge of instructional strategies] (Simge, weekly post interview, chemical equilibrium).

In this example, she realized her students' difficulties while teaching heterogeneous equilibrium. To eliminate their difficulties, with the influence of her process science teaching orientation she used an instructional strategy, i.e., make them draw graphs.

#### **4.6. The experienced teachers had much more two-way interactions among PCK components than the novice teacher**

To delve into the complexities regarding the nature of interactions among PCK components, I did an analysis for the directions of these interactions and drew maps to show the directions of the interactions. A closer look at the direction of interactions among PCK components for all teachers revealed that the interactions

among the components were one-way or two-way directions. An example for one-way direction was that the teachers' knowledge of curriculum always informed their knowledge of assessment in all PCK maps. An example for two-way direction was that in some teaching segments, the teachers' knowledge of learner informed their knowledge of instructional strategies whereas in some teaching segments their knowledge of instructional strategies informed their knowledge of learner component.

In Burak's teaching segments for both topics, the interactions between instructional strategies and assessment, curriculum and assessment, and curriculum and instructional strategies components showed one-way direction (Figure 4.5). This means that one of the components informed another one.

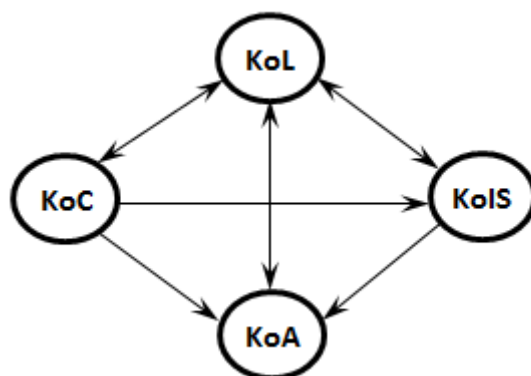

**Figure 4.5** Map for directions of the interactions in Burak's teaching segments

To illustrate, in all teaching segments of Burak where he linked instructional strategies with his assessment component, always instructional strategies informed his assessment component. A close analysis among sub-component of this interaction showed that his knowledge of topic-specific representations most frequently informed what to assess sub-component. For instance, during teaching chemical equilibrium, he emphasized that in a closed system and at constant temperature, the concentrations of the reactants and products must be constant at equilibrium state. After stating this condition, he used the following illustration which shows a hypothetical reaction of  $X(g) \leftrightarrow Y(g)$ , with X represented by circle and Y represented by triangle (Figure 4.6) (observation of the instructions).

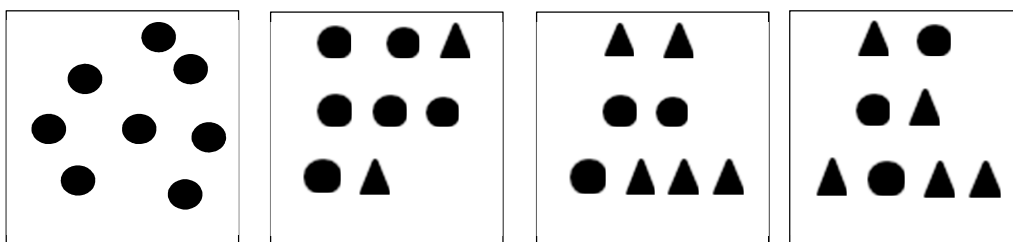

**Figure 4.6** Hypothetical reaction of  $X(g) \leftrightarrow Y(g)$

He explained the condition stated above by showing the reactants and products at sub-microscopic level before and after the system reaches equilibrium. When the reason of using that illustration was asked during the weekly post-interview, he stated that in order to picture or visualize the condition at sub-microscopic level, he used it. After a while, at the end of the topic, he made an exam and asked the following question:

The following diagrams represent a hypothetical reaction of  $A(g) \leftrightarrow B(g)$ , with A represented by white spheres and B represented by grey spheres. The sequence from left to right represents the system as time passes. Use given diagrams for questions i and ii

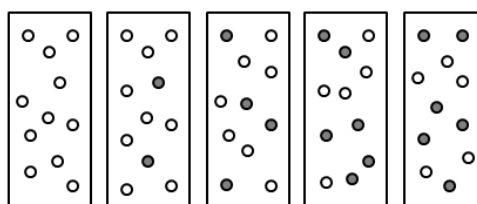

- i) Do the diagrams indicate that the system reaches an equilibrium state? Explain.
- ii) What is the equilibrium constant for the given reaction?

During the weekly post-interview, we talked about the exam:

Researcher: There was a question in the exam related to sub-microscopic level. Why did you ask this question?

Burak: It is important to visualize the particles at sub-microscopic level. I always paid attention to it [sub-microscopic level] in the classroom; therefore I tried to ask this kind of questions.

Researcher: Could they solve the question?

Burak: They could solve it much better than I expected, because they practiced it in the classroom. (Burak, weekly post-interview, chemical equilibrium)

All the explanations above indicated that his knowledge of topic-specific representations (the use of representations at sub-microscopic level) informed his knowledge about what to assess sub-component.

Regarding curriculum and assessment interaction, always his knowledge of curriculum informed his knowledge of assessment. Specifically, his knowledge of goals and objectives most frequently informed what to assess sub-component. An example for this interaction, in order to evaluate the objective in the curriculum [students explain that how and why temperature affects reaction rate], Burak asked a question that was “Why does rate of reaction increases when temperature increases?” in the open-ended exam. After the exam, we talked about the exam and the reason of using this question. He explained that

When I asked them [students] what is the effect of temperature on rate? They told that it increases rate of reaction. When I asked them how and why temperature affects reaction rate, most of them could not answer it properly. I am trying to ensure them to explain the things conceptually [knowledge of curriculum]. Therefore, I asked it [the question] [knowledge of assessment] (Burak, weekly post-interview, reaction rate).

Moreover, in all teaching segments where Burak connected curriculum and instructional strategies components, always his knowledge of curriculum informed his knowledge of instructional strategies. Among sub-components of this interaction, his knowledge of goals and objectives most frequently informed his knowledge of topic-specific representations. For example, in order to teach Le Chatelier principle, he drew concentration vs. reaction progress and rate v.s reaction progress graphs, and

expected students to draw these graphs for different reactions (observations of instruction). During the post-interview, he stated that:

Actually, teaching Le Chatelier [principle] verbally is easy. They only thought Le Chatelier [principle] as effect and response. However, when the students draw concentration vs. reaction progress and rate vs. reaction progress graphs, they understand much better it. They also understand the relation between reaction rate and chemical equilibrium. Therefore, I used these graphs to teach this principle. They better understand what happens in a system when temperature is increased. In order to visualize it [Le Chatelier principle], use of graphs is much better [his knowledge of curriculum informed his knowledge of instructional strategies] (Burak, weekly post-interview, chemical equilibrium).

On the other hand, in Burak's teaching segments, I observed that the interactions between learner and assessment, learner and curriculum and learner and instructional strategies are two-way (Figure 4.5). This means that in some teaching segments his knowledge of learner informed his knowledge of assessment whereas in other teaching segments his knowledge of assessment informed his knowledge of learner. For instance, Burak realized his students' misconception after using an assessment task. In the weekly post-interview, he stated that

After the exam [knowledge of assessment], I realized that my students had a misunderstanding, which is concentrations of reactants and products are equal to each other at equilibrium state [knowledge of learner]. Actually, when reaction mixture has reached equilibrium, the concentrations of reactants and products no longer change. After realizing their misunderstanding, I re-explained that part again [his knowledge of assessment informed his knowledge of learner] (Burak, weekly post-interviews about instructions, chemical equilibrium).

In another example, his knowledge of learner informed his knowledge of assessment. He stated in the post interviews "I knew that the students had difficulties in understanding what happens to a heterogeneous equilibrium when a stress is applied.

[knowledge of students' difficulties]. Then, I prepared a worksheet to decide whether students were able to cope with these difficulties" [knowledge of assessment].

The worksheet questions were:

Given the reaction

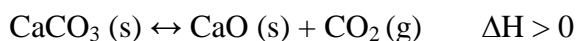

- 1) Decide the direction of reaction when following stresses are applied one by one and compare the initial and final concentrations (or mass for solids) of the substances.

Applied Stress	Direction of Reaction	Mass of $\text{CaCO}_3$	Mass of $\text{CaO}$	Concentration of $\text{CO}_2$
Adding $\text{CaCO}_3$				
Adding $\text{CO}_2$ (g)				
Decreasing Volume				
Increasing Temperature				

- 2) Draw concentration vs. reaction pathway and rate vs. reaction pathway graphs for each case

- a) Adding  $\text{CaCO}_3$    b) Decreasing volume   c) Increasing temperature

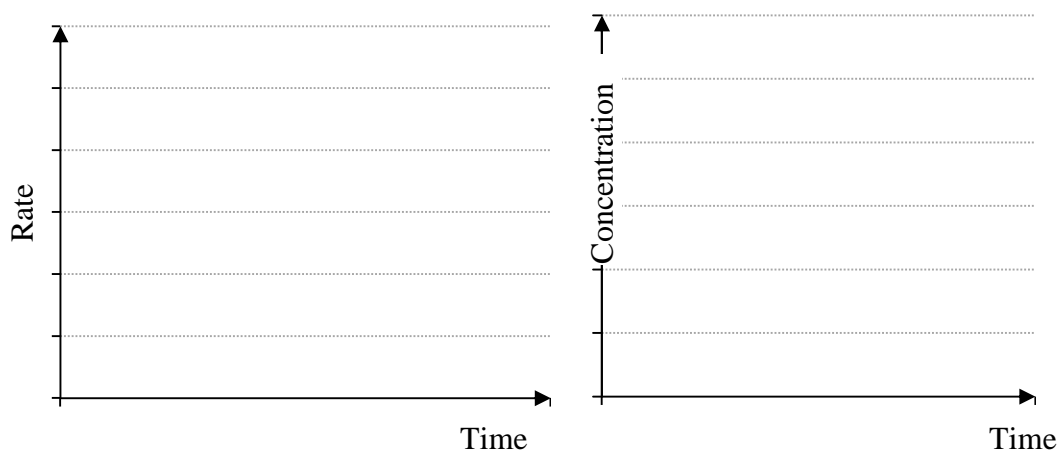

Similar to Burak, teaching segments of Simge for both topics revealed that the interactions between instructional strategies and assessment, curriculum and

assessment, and curriculum and instructional strategies components showed one-way direction. On the other hand, interactions between learner and assessment, curriculum and learner, and learner and instructional strategies were two-way direction (see Figure 4.7).

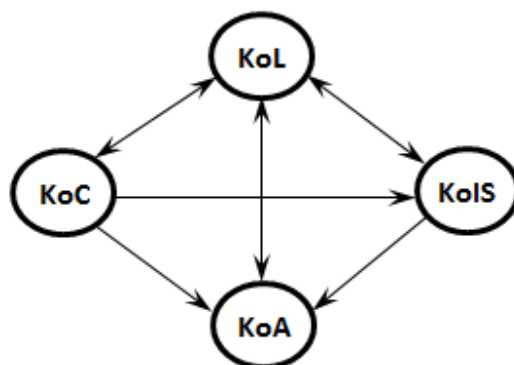

**Figure 4.7** Map for directions of the interactions in Simge's teaching segments

For example, regarding curriculum and instructional strategies interaction, always her knowledge of curriculum informed her knowledge of instructional strategies. Among sub-components of this interaction, her knowledge of goals and objectives most frequently informed his knowledge of topic-specific representations. For example, in order to teach activated complex that is an unstable and intermediate state, she utilized an analogy (Simge, observations of instructions, reaction rate). During the instruction, she started to teach activation complex. She stated that:

Simge: Have you heard anything about activated complex?

Students: .... [No answer]

Simge: The activated complex is an unstable group of atoms that occurs in the highest energy state throughout a chemical reaction. In a chemical reaction, the activated complex behaves as an intermediate between the reactants and the products. It is the temporary unstable group of atoms formed when activation energy is reached. In this temporary state, all the bonds between reactant molecules are not completely broken, and all the bonds

between products molecules are not completely formed. Think about it: [Sevgi], you are tied up with [Elif]. While you are leaving from Elif, you are tied up with [Hakan]. Neither you have left from Elif nor are you tied up with Hakan. It is an intermediary complex. (Simge, observation of instructions, reaction rate)

After the lesson, I asked her the reason of using this analogy explained above, she stated that:

I wanted to explain the activated complex which is an intermediate and unstable complex [knowledge of curriculum]. I used it [analogy] [knowledge of instructional strategies] in order to specify that all the bonds between reactant molecules are not completely broken, and all the bonds between products molecules are not completely formed (Simge, weekly post-interview, reaction rate).

There was also one-way interaction between curriculum and assessment in her reaction rate and chemical equilibrium teaching segments. Specifically, her knowledge of goals and objectives most frequently informed her how to assess sub-component. For example, in order to evaluate the objective in the curriculum [students determine the rate law for given reactions and calculate rate constant], she conducted a pop quiz (Simge, weekly post-interviews about instructions, reaction rate). She provided evidence for this interaction in the weekly post-interview:

Researcher: You conducted a pop-quiz? What is the reason of using it?

Simge: They learned rate law and how to calculate rate constant [knowledge of curriculum]. In order to evaluate them, I prepared that pop quiz [knowledge of assessment]. I noticed that they learned writing rate law and calculating rate constant and did not have any difficulty in general (Simge, weekly post-interview, reaction rate).

On the other hand, in Simge's teaching segments, I observed that the interactions between learner and assessment, learner and curriculum and learner and instructional strategies are two-way (see Figure 4.7). Regarding two-way interaction between learner and curriculum components, I observed that she explained chemical

equilibrium by using students' prior knowledge about rate of reaction. She also explained equilibrium constant by using rate equation as seen below:

Teacher: What is chemical equilibrium?

Student: There should be a reaction. Also, there should be a reverse reaction. If one reaction is endothermic, the other one [reverse reaction] should be exothermic. It should be reversible.

Teacher: Good. It should be reversible. Equilibrium is a state in which there are no observable changes as time goes by. Chemical equilibrium is achieved when the rates of forward and reverse reactions are equal, and the concentrations of reactant and products remain constant. Please, tell me the rate law for only forward reaction of  $aA + bB \leftrightarrow cC + dD$ .

Student:  $\text{Rate} = k[A]^a [B]^b$

Teacher: Good. Let's write it as  $\text{Rate}_{(\text{forward})} = k_f [A]^a [B]^b$ . Let's tell me the rate law for reverse reaction.

Student:  $\text{Rate}_{(\text{reverse})} = k_r [C]^c [D]^d$ .

Teacher: What did we say? What is the first condition for the chemical equilibrium?

Student 1: The rates of forward and reverse reactions should be equal.

Student 2: We can equate them [rate law for forward and reverse reactions].

Teacher: Let's write the equation as  $k_f [A]^a [B]^b = k_r [C]^c [D]^d$ .

$K_c = k_f/k_r = ([C]^c [D]^d)/([A]^a [B]^b)$  (Simge, observation of instructions, reaction rate).

In the weekly post-interview, I asked her how she explained chemical equilibrium, she stated that

First, students should keep reaction rate in mind to learn chemical equilibrium [knowledge of requirements for learning]. I used rate equation while deriving equilibrium constant expression [knowledge about goals and objectives]. Students should see that we can derive equilibrium constant expression based on rate equation. However, generally our students think that there was not any relation between the topics. Therefore, I tried to remind the connections between topics when it is needed. For instance, I wanted the students to write

forward and reverse rate, and then made a ratio between them in order to see the relation between rate and equilibrium. [Teachers' knowledge of requirements for learning and knowledge about horizontal curriculum informed each other]. However, some of students had difficulties while deriving the equilibrium equation and could not make a connection between them [knowledge about horizontal curriculum informed her knowledge about students' difficulties] (Simge, weekly post-interviews about instructions, reaction rate).

In the example above, Simge's knowledge of learner and knowledge of curriculum informed each other reciprocally.

The next two examples showed that in some teaching segments her knowledge of learner informed her knowledge of instructional strategies whereas in some teaching segments her knowledge of instructional strategies informed her knowledge of learner. The example below indicated that Simge utilized a topic-specific representation to overcome her students' misconception. In other words, her knowledge of learner informed her knowledge of instructional strategies. In the weekly post-interview, Simge stated that

Simge: Catalysts allow a reaction to occur with a reasonable rate at much lower energy. Some of the students think that catalyst also decrease heat of reaction while others think that it increases heat of reaction. This is a misconception. They could not understand it.

Researcher: How did you address their misconception when you realized it?

Simge: I tried to explain it by drawing graphs [see Figure 4.8] and show that heat of reaction does not change. The potential energy of reactants and products does not change. The reaction occurs with lower activation energy (Simge, weekly post-interview, reaction rate).

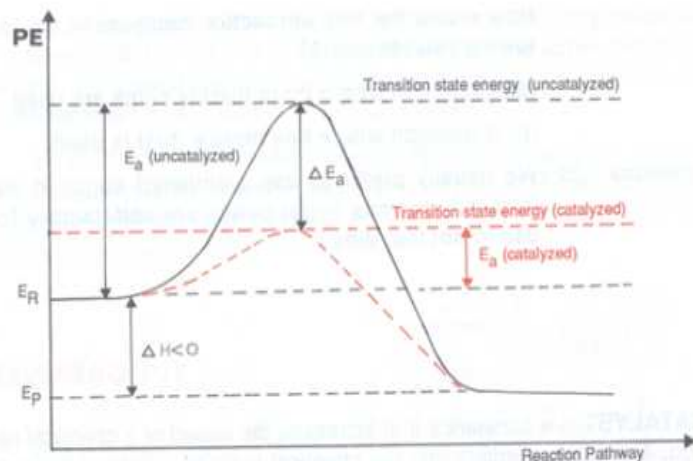

**Figure 4.8** Energy profiles for a catalyzed and uncatalyzed reaction

The following example showed that her knowledge of instructional strategies informed her knowledge of learner. She showed a simulation for the equilibrium reaction:  $\text{N}_2\text{O}_4(\text{g}) \leftrightarrow 2\text{NO}_2(\text{g})$  during the instruction. In the weekly post-interview, I asked her:

Researcher: Why did you prefer to use the simulation about the equilibrium reaction of dinitrogen tetroxide ( $\text{N}_2\text{O}_4$ )?

Teacher: I wanted to show that chemical reactions can reach equilibrium from both sides. A system can reach equilibrium by adding reactant, product or mixture of them. However, as you see, some of the students had difficulties in understanding it [her knowledge of instructional strategies informed her knowledge of learner] (Simege, weekly post-interview, reaction rate).

On the other hand, in all teaching segments of Betül, I observed one-way interactions among all PCK components except the interaction between knowledge of learner and instructional strategies components (see Figure 4.9).

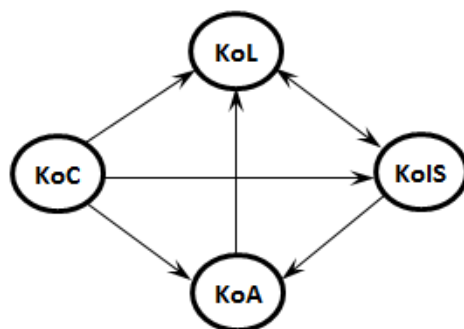

**Figure 4.9** Map for directions of the interactions in Betül's teaching segments

In all teaching segments, Betül's knowledge of curriculum always informed learner, instructional strategies and assessment components. Her knowledge of assessment always informed her knowledge of learner. In addition, her knowledge of instructional strategies always informed her knowledge of assessment. For instance, the following interview excerpt below provided evidence for that her knowledge of assessment component (how to assess sub-component) informed her knowledge of areas of students' difficulties. She made a quiz in reaction rate topic. In the post-interviews, Betül stated:

Quiz results [how to assess sub-component] showed that the students had difficulties in writing rate law for elementary steps in a reaction mechanism. When I gave them a reaction equation and rate law for this reaction, they are still confusing that why they are different from each other. In addition, while determining the order of the reaction for a reactant, they are still confusing whether they decide it based on reaction equation or one of the elementary steps in a reaction mechanism [knowledge of areas of students' difficulties] (Betül, weekly post-interview, reaction rate).

Another one-way interaction was observed between Betül's knowledge of goals and objectives (sub-component of knowledge of curriculum) and how to assess sub-component. In the post-interviews, I asked her:

Researcher: How did you assess your students' understanding in chemical equilibrium topic?

Betül: Last week, we solved questions about reaction quotient ( $Q_c$ ). Then, in order to assess them [the students], I conducted a pop-quiz. Thus, I evaluated their understanding on this topic.

Furthermore, in all teaching segments, Betül had only one interaction between knowledge of instructional strategies and knowledge of assessment components in chemical equilibrium topic. While teaching Le Chatelier's principle, she drew concentration vs. time and rate vs. time graphs when reactants or products are added, and volume is changed. For instance, she drew concentration vs. time graph for the equilibrium reaction,  $N_2(g)+3H_2(g)\leftrightarrow 2NH_3(g)$  (see Figure 4.10), if  $NH_3$  is added as seen below:

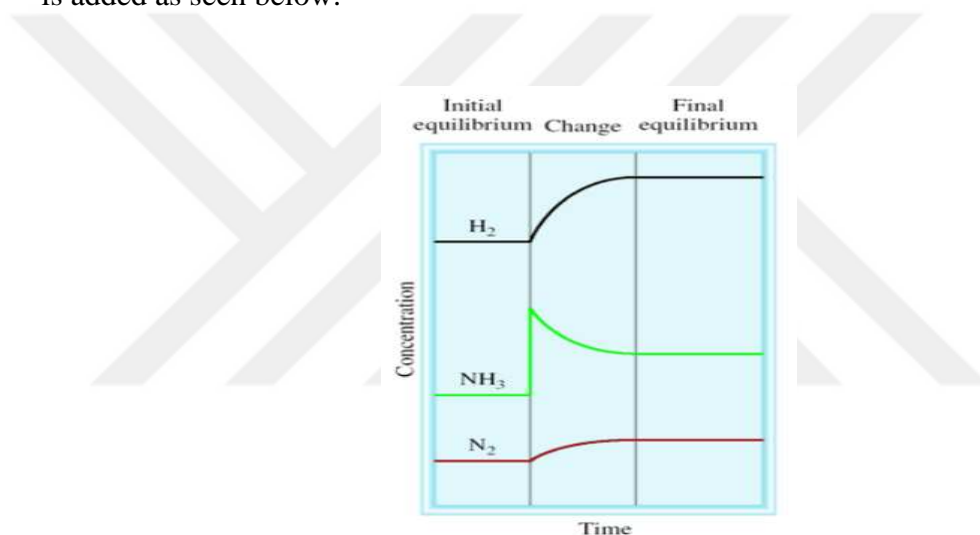

**Figure 4.10** Concentration vs. time graph drawn in the classroom

In the weekly post-interview, Betül stated that “In the final exam, I will ask the students to draw concentration vs. reaction progress and rate vs. reaction progress graphs when nitrogen is added, for the equilibrium reaction,  $N_2(g)+3H_2(g)\leftrightarrow 2NH_3(g)$ . We discussed these graphs in the classroom. We will see whether they can draw or not”. In this example, it is seen that her knowledge of topic-specific representations informed what to assess sub-component.

On the other hand, two-way interaction was only observed between knowledge of learner and instructional strategies components. The observation of the instruction and interview excerpt below reflected the interaction in which her

knowledge of instructional strategies informed her knowledge of learner. Specifically, her knowledge of topic-specific representations informed her knowledge of areas of students' difficulties sub-component. During the instruction, she asked:

Betül: What about the effect of temperature? If we increase the temperature, what is the effect of it on particles?

Student: Their kinetic energy increases and they collide each other much more.

Betül: Good. Their energy increases and the number of collision increases. As they move faster, the frequency of collisions also increases. When we increase the temperature, we give energy to the particles, and this makes them move faster. When the particles collide with each other much more, reaction goes faster. How do you interpret this graph? (see Figure 4.11). It is an important graph. The graph shows the relationship between number of particles and collision energy. ( $T_2 > T_1$ ).

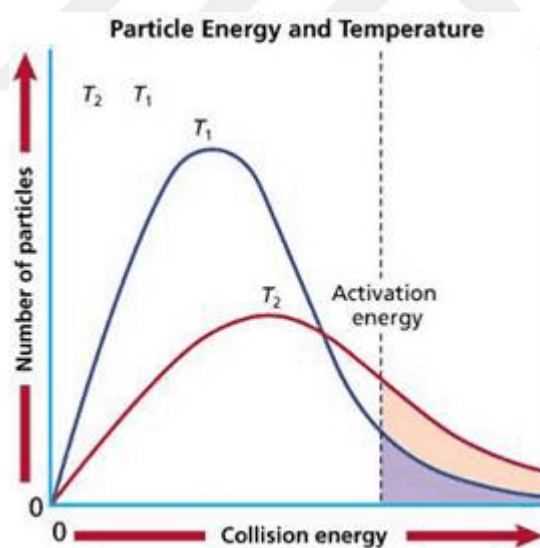

**Figure 4.11** Number of particles vs. collision energy

Student 1: ... [No answer]

Betül: What do you think about it?

Student 2: ... [No answer]

Betül: This parts under the graph, gives me the number of particles that exist the activation energy. When you look at the temperature 2 ( $T_2$ ), the reaction which occurs at  $T_2$ , you see the number of particles which exist the activation energy is higher than the reaction which occurs at  $T_1$ .

Student 3: I do not understand it.  $T_1$  indicates the highest point for the number of particles, but you said that the number of particles that have activation energy is much more at  $T_2$ .

Student 4: Teacher, I do not understand it. Can you repeat it? (Betül, observation of instructions, reaction rate)

In the weekly post-interview, we talked about this instruction. Betül stated that

I showed them a graph that was related to the number of particles vs. kinetic energy [knowledge of topic-specific representations]. The graph shows that when temperature increases, the number of particles with energy equal to or greater than the activation energy increases. Students had difficulties in interpreting the graph. The area under the curve gives the number of particles; however, this explanation did not make sense for them. They said that the curve under the  $T_1$  shows the highest point for the number of particles, and so how the number of particles that have activation energy is much more at  $T_2$  [knowledge of areas of students' difficulties]. I tried to explain it (Betül, weekly post-interview, reaction rate).

The observation of the instruction and interview excerpt above reflected the interaction in which her knowledge of topic-specific representations informed her knowledge of areas of students' difficulties.

Another example reflected the interaction in which knowledge of learner informed her knowledge of instructional strategies. Betül used an analogy during teaching reaction rate. That was:

Assume that, you are driving by a car along 240 km. It takes 2 hours. What is your average velocity? [Students answered] The answer is 120 km/h. Then, do you drive with the same velocity (120 km/h) along 240 km? [Students answered] No, it changes. I sometimes drive faster and sometimes slower. So,

are the average and instantaneous velocity same or not? [Students answered]

No. (Betül, observation of instruction, reaction rate)

In the weekly post-interview, I asked why she used this analogy in her instruction. She stated that “I realized some of the students thought that reactions occur with an instantaneous rate. However, the rate of reaction changes in time. In order to help them, I used this analogy” (Betül, weekly post-interview). This example indicated that her knowledge of areas of students’ difficulties informed her knowledge of topic-specific representations sub-component.

#### **4.7. The experienced teachers were more successful than the novice teacher in translating their knowledge into practice in terms of the integration among PCK components**

Results of the analyses of pre- and post-interviews showed that some of the interplays were only observed at knowledge level, while others were translated into practice. For instance, during card-sorting task before the instructions, Simge and Betül stated that some of their instructions would be based on guided inquiry; however, I did not observe any lesson based on guided-inquiry. It can be also stressed that I did not observe any subject-specific instructional strategies (e.g., inquiry, learning cycle) in all teachers’ instructions. Instead, their instructions were mainly based on teacher-centered. Therefore, it can be concluded that they were not able to translate their knowledge about subject-specific instructional strategies from knowledge into practice. On the other hand, they planned to use many topic-specific instructional strategies (e.g., experiments, animations), and then they used them during their instructions. Accordingly, they could translate their knowledge about topic-specific instructional strategies into practice.

When we compared the teachers, the experienced teachers were more successful than the novice teacher in translating their knowledge into practice in terms of the integration among PCK components. Specifically, Burak could mostly translate the connections among PCK components from knowledge into practice. For example, he emphasized that the students’ difficulties and misconceptions would

influence her instructions and lesson plan. Accordingly, in most of his teaching segments, he used a rich repertoire of topic-specific instructional strategies in order to overcome his students' misunderstandings and difficulties. He made the connection between knowledge of learner and instructional strategies and easily translated his knowledge into practice. To illustrate, in the pre-interview in the form of CoRe, Burak stated that

Students usually have difficulties in understanding dynamic equilibrium. In order to help them, I usually prefer to teach this concept by drawing concentration vs. time and reaction rate vs. time graphs when we add reactants or products, and change volume or temperature. I believe that they will learn better when they understand these graphs (Burak, pre-interview in the form of CoRe, chemical equilibrium)

During the instruction, I observed that he drew concentration vs. time and reaction rate vs. time graphs for different reactions as he mentioned in the pre-interview in order to increase his students' understanding. For instance, he wanted his students to draw concentration vs. time and rate vs. time graphs for the equilibrium reaction,  $\text{H}_2(\text{g}) + \text{I}_2(\text{g}) \leftrightarrow 2\text{HI}(\text{g})$ , if a)  $\text{H}_2$  is added, and b) volume is decreased to half of it. Then, he gave time to all students for drawing these graphs. He checked their drawings by rounding in the class. When the students had difficulties in drawing the graphs, he gave the necessary supports. Then, he drew the graphs on the blackboard and explained them in detail (Burak, observation of instructions, chemical equilibrium). It can be inferred that the interplay of knowledge of learner and instructional strategies were translated from knowledge into practice.

The next example also showed that the interaction between knowledge of learner and instructional strategies were translated from knowledge into practice. Before teaching rate of reaction, in the pre-interview in the form of CoRe, Burak stated that

Students think that catalysts always increase reaction rate. But, they do not take inhibitors into consideration. Since I know their misunderstanding, I plan an experiment in which they use an inhibitor. I know they will be confused.

Then, I observed that he made an instruction in which students made an experiment to observe the effect of inhibitor on reaction rate. He provided laboratory procedure step-by-step that the students had to follow:

Take two test tubes and place 5 mL of 1M HNO<sub>3</sub> in each. Label them I and II. Add a spoonful of CdSO<sub>4</sub> to the test tube II. Obtain two pieces of Mg ribbon in equal lengths, about 1 cm long. Place the ribbons in the test tubes at the same moment and measure the time. Observe the changes in test tubes and record the time when Mg ribbons have reacted completely.

During the implementation of this experiment, I observed that most of the students were confused. The students were talking each other about why the rate of reaction did not increase. They said that CdSO<sub>4</sub> had to be the catalyst but it decreased the rate of reaction. What could be the reason for it? After they collected the data, they had to answer the following questions: Which substance is used as a catalyst? How did the catalyst affect the rate of reaction? Explain why? In addition, they had to write a conclusion for this experiment. The teacher gave time to the students in order to answer these questions. Some of the students discussed their findings and the reasons for it in groups, while others read the related part from the book. Then, the teachers collected the answer sheets in order to evaluate them. In the weekly post-interview, I asked:

Researcher: How was the experiment? Were your students confused as you expected?

Burak: The students came into conflict with their findings during the experiment. Then, they tried to find the reason of this finding. Some of them remembered inhibitors from the instruction. Some of them wrote the answer correctly and stated that CdSO<sub>4</sub> is an inhibitor. Therefore, it decreases the rate of reaction. Some of them could not explain it correctly. They lost some points. While giving feedback to them, I re-explained it again and drew their attention to inhibitors. (Burak, weekly post-interview, reaction rate)

In the example above, it can be concluded that the interaction between knowledge of learner and instructional strategies were translated from knowledge into practice.

Similarly, Simge usually were able to translate the interrelatedness among PCK components from knowledge into practice. For instance, in the pre-interview conducted before reaction rate, she stated that

We need to increase the rate of some reactions in our environment while we decrease the rate of some others. In order to make this, we should know the factors that affect reaction rate. I will give some examples from daily life. For instance, the recommended duration is 6 months for 'minced meat' in the freezer while it is 8 months for 'meat'. I will ask them what can be the reason of this difference. In addition, I asked them why we put our foods in the freezer. (Simge, pre-interview in the form of CoRe, reaction rate)

Then, during the instruction, I observed that she provided daily life examples to teach factors effecting reaction rate. She initiated a discussion to elicit the students' ideas by using these examples from daily-life as she planned (observation of instructions).

During the instruction, Simge asked:

Simge: Do the meat go off much faster in the freezer or outside?

Student 1: The foods go off much faster outside than the freezer.

Simge: Why?

Student 2: Because, temperature increases rate of reaction.

Simge: Good.

Simge: In the operating manual of the freezer, it is written that the recommended duration is 6 months for 'minced meat' in the freezer while it is 8 months for 'meat'. Have you ever seen this information?

Student 3: Yes.

Simge: What can be the reason?

Student 3: Surface area.

Simge: When we increase the surface area, it increases reaction rate. (Simge, observation of the instructions, reaction rate)

This example showed that in light of her everyday coping science teaching orientation, her knowledge of curriculum informed her knowledge of topic-specific

representations. Therefore, it can be concluded that Simge was able to translate this interaction from knowledge into practice.

On the other hand, Betül stated that the students' difficulties and misconceptions would influence her instructions and lesson plans. She also added that when she realized a misconception, she would try to find different examples to solve their misconception. This view is reflected in the interview excerpt below:

Researcher: How will your students' difficulties and misconceptions affect your instruction and your lesson plans?

Betül: Actually, while making lesson plan, their difficulties affect my plan. While making lesson plan, I investigate their possible difficulties and misconception and take them into consideration. When I realize a misconception, I try to find different examples to address their misconception (Betül, pre-interview in the form of CoRe, reaction rate).

However, in most of her teaching segments, when the students failed to understand the initial explanations, she usually repeated her explanations didactically without using an additional instructional strategy such as analogy, illustrations, demonstrations, etc. (observations of instruction).

Moreover, in the pre-interview in the form of CoRe, she stated that she wanted to relate chemistry to daily-life. In light of her everyday coping science teaching orientation, while teaching reaction rate topic, she stated that she planned to give daily life examples. In the pre-interview in the form of CoRe, she stated that

For instance, in the industrial area, how much the reactions occur slow or fast is very important. In addition, I can also give examples from our body. I can give examples such as: In which conditions do the reactions in our body occur or not? Do these reactions need catalyst or not? (Betül, pre-interview in the form of CoRe, reaction rate)

However, she did not provide any daily-life examples in this topic during her instruction as I observed. She did not reflect her decisions on her teaching sessions. Therefore, for these examples, it can be inferred that she could not translate her PCK from knowledge into practice.

On the other hand, for some teaching segments, she could translate her knowledge into practice in terms of interaction among the components. For example, in the pre-interview in the form of CoRe, she stated that

Betül: I will use graphs while teaching reaction rate.

Researcher: Which graphs?

Betül: Number of molecules vs. time graph. We also calculate average and instantaneous rate from a graph. First, we draw a graph and then calculate them. In addition, we draw number of particles vs. collision energy graph.

Researcher: Why do you prefer to use the graphs while teaching reaction rate?

Betül: Drawing graphs help students' understandings. Drawing graphs, making interpretations from a graph, and using the data from the graph are important for them (Betül, in the pre-interview in the form of CoRe, reaction rate).

In light of her process science teaching orientation, in order to teach the concepts in reaction rate [knowledge of curriculum], she drew graphs (e.g., number of molecules vs. time graph) and sometimes she wanted her students to draw graphs and make interpretations [knowledge of instructional strategies] (observations of instruction). In this example, it is shown that the integrations between these components were translated from knowledge into practice.

#### **4.8. Teacher self-efficacy appeared to play a role in their use of PCK components and constructing interactions among them**

During in-depth analysis of teaching segments, the role of teachers' self-efficacy in the teachers' use of PCK components as well as their construction of interplays among the components was observed. Especially, Betül's teaching segments and the interviews provided representative examples of how teacher efficacy plays a role in the enactment of PCK. For instance, in the pre-interview, I asked her

Researcher: How well can you elicit your students' difficulties and misconceptions?

Betül: I feel deficient myself about that point. For example, I have been teaching for different classes, and in these classes different things come to students' mind that I did not consider before. Students can be confused. Therefore, I feel inadequate myself about that point [difficulties and misconceptions]. I always attribute it to teaching experience. However, it will be better in time.

Researcher: Which misconceptions may students have related to reaction rate?

Betül: [She thought about the question for a while]. It does not come to my mind.

Researcher: How well can you provide alternative instructional strategies when your students have difficulties or misconceptions during teaching?

Betül: I cannot say that I feel sufficient myself. Therefore, I am studying the topic from different sources to find different examples for supporting students with alternative examples (Betül, pre-interview in the form of CoRe, reaction rate).

The interview excerpt above indicated that she partially believed her capability to identify students' difficulties and misconceptions, and to use alternative strategies or explanations to deal with them. Moreover, for knowledge of instructional strategies, she answered the question:

Researcher: How well can you use instructional strategies?

Betül: I do not feel completely sufficient in using different instructional strategies, because I did not apply the strategies such as experiments in this topic before. I do not have any idea about the possible problems and difficulties while conducting them [experiments] (Betül, pre-interview in the form of CoRe, reaction rate).

Moreover, she added that use of analogies and daily life examples were easy but she was not comfortable with using them in class, because she might cause misconceptions in students' mind (Betül, pre-interview in the form of CoRe, chemical equilibrium). Along this line, she could not enact her PCK effectively in actual classroom. During the teaching of reaction rate and chemical equilibrium,

when her students had a difficulty in understanding the concepts, she mostly warned them and re-explained those concepts again (observation of the instruction). For example, during the instruction, she stated that “you are still confusing the effect of catalyst on chemical equilibrium. Catalyst accelerates reaction rate; however, it does not have an influence on equilibrium position.” (observation of the instruction). After the instruction, she stated that “I realized that the students did not understand the effect of catalyst on chemical equilibrium. Therefore, I warned them and explained it again.” (Betül, weekly post-interview, chemical equilibrium) Actually, she could have asked the students why they thought like that. She also could have explained the reason of this situation in detail with an additional instructional strategy (e.g., animation, simulation, and graph). However, she avoided using alternative instructional strategies to overcome her students’ difficulties since she felt uncomfortable with using them. Therefore, limited interaction between knowledge of learner and instructional strategies was observed in Betül’s teaching the topics when compared with that of the experienced teachers. The novice teacher, Betül attributed her low self-efficacy regarding knowledge of learner and instructional strategies to her lack of teaching experience, because she taught reaction rate and chemical equilibrium topics for the first time in a classroom environment. During pre-interview, she stated:

I do not have enough teaching experience; therefore, it may be difficult for me to identify students’ difficulties and misconceptions about the concepts in reaction rate and equilibrium topics. In addition, when students have difficulties and misconceptions during teaching, I do not consider myself fully capable to provide alternative instructional strategies to overcome their difficulties. However, I believe that after a few years, when I gain enough experience, it will be better. After gaining experience about learners and their difficulties, next year it will be better for me (Betül, pre-interview in the form of CoRe, reaction rate).

On the other hand, Betül believed her knowledge of curriculum. The interview data in combination with classroom observations showed that she frequently integrated

her knowledge about goals and objectives whereas she could less frequently integrate horizontal and vertical curriculum knowledge into her PCK when needed. During pre- interview, she stated:

Researcher: How well could you connect reaction rate and chemical equilibrium topics to the other topics within 11<sup>th</sup> grade and across grades?

Betül: I do not have an experience about teaching these topics. I sometimes felt insufficient myself to connect the topics to the others. I think that I cannot meet the students' needs completely. (Betül, pre-interview in the form of CoRe)

On the other hand, the experienced teachers believed their capability to perform their PCK effectively; therefore, they could frequently integrate and enact the components of PCK into their actual classrooms. Specially, Burak believed his capability to use different instructional strategies in order to overcome students' difficulties and misconceptions. When I asked him

Researcher: How well can you provide alternative instructional strategies when your students have difficulties or misconceptions?

Burak: If I know the students one to one, it is more efficient, because I can provide different examples [instructional strategies] related to students' own experiences. There is no limit for me in providing different examples. This happens in time with getting experience and reading a lot. If you read much more, you can provide much more different examples (Burak, pre-interview in the form of CoRe, reaction rate).

The interview excerpt above provided evidence for that he believed his capability to provide different instructional strategies when it is needed. Moreover, he attributed his high self-efficacy in the enactment of PCK components to his teaching experience and reading a lot. I also observed that when he identified students' difficulties, he could provide additional instructional strategies to overcome their difficulties (e.g., daily life examples, analogies, etc.). For example, before the instruction, Burak was aware of the students' possible difficulties and described how he would help them overcome their difficulties. He said:

Some of the students have difficulties in understanding reaction rate at sub-microscopic level, and why the rate of reaction is fast at the beginning of the reaction. Therefore, I prepared an illustration to show the reaction in which A is converted to B ( $A \rightarrow B$ ) at sub-microscopic level. They can see the changes in the number of particles in terms of A and B in each time interval. In this topic, they will also learn activation energy and collisions of molecules. When they understand what happens at sub-microscopic level now, this will help them comprehend activation energy and collisions of molecules (Burak, pre-interview in the form of CoRe, reaction rate).

During the instruction, he initiated a discussion about the changes in the concentration of A and B molecules in time at sub-microscopic level, and wanted them to explain the illustration below (see Figure 4.12).

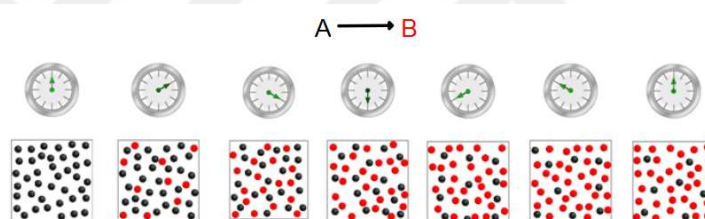

**Figure 4.12** The reaction in which A is converted to B ( $A \rightarrow B$ ) at sub-microscopic level

He sensed that some students had difficulties in understanding concentration change in each time interval and why the rate of reaction is fast at the beginning of the reaction. He tried to elicit all students' ideas and their reasoning. This discussion led the students to comprehend that changes of the concentration of A and B molecules in each time interval and why the rate of reaction is fast at the beginning of the reaction. In the weekly post-interview, Burak said that "The explaining concepts at sub-microscopic level is always a difficulty for them. I am aware of it. With that illustration, we discussed it. I was able to help them comprehend it." This example showed that Burak's beliefs about his capability to make students comprehend explanations at sub-microscopic level appeared to play a role in their

use of knowledge of learner and instructional strategies and the constructing the interaction between them.

Similarly, Simge's teaching segments and interviews data indicated the role of teacher self-efficacy in her use of PCK components as well as the construction of interplays between the components. Simge's teaching segments provided representative examples of how teacher efficacy plays a role in the enactment of PCK. For instance, she believed her knowledge of curriculum. She also could translate her curriculum knowledge into her teachings when needed (observation of instruction). She also stated that "At the beginning of my teaching profession, I did not have enough knowledge about chemistry curriculum. Now, I have knowledge about objectives, what we have to teach and what we do not have to teach" (Simge, pre-interview in the form of CoRe, reaction rate). She attributed her high self-efficacy regarding knowledge of curriculum to her teaching experience. Moreover, Simge believed her capability to use different instructional strategies in order to address the students' difficulties and misconceptions. When I asked her

Researcher: How well can you elicit your students' difficulties and misconceptions?

Simge: Actually, I can predict in which points the students have problems. As time passes, I have learnt the things that the students can learn easily or have difficulties. For instance, now I am teaching three different classes, and the students in these classes usually ask the same questions. They usually have difficulties at the similar points or ask the similar questions. Consequently, over the years I have learnt in which points the students have problems. If the students do not ask any question related to these points, I usually draw their attention to these points and ask questions to elicit their ideas. Therefore, teaching experience is very important.

Researcher: Which misconceptions may students have related to reaction rate topic? Simge: The students do not comprehend the difference between average and instantaneous reaction rate. They have difficulty in

understanding activation energy. They do not think that activation energy is a requirement for all reactions. This is a misconception.

Researcher: How well can you provide alternative instructional strategies when your students have difficulties or misconceptions during teaching?

Simge: I can provide many different examples [instructional strategies] and solve different questions when I realized their difficulties. I point out them to the point that they have difficulties and warn them. (Simge, pre-interview in the form of CoRe, reaction rate)

The interview excerpt above provided evidence for that she believed her capability to provide different instructional strategies in order to overcome her students' difficulties. Moreover, she attributed her high self-efficacy in the enactment of PCK components to her teaching experience. During her teachings, I observed that when she realized the students' difficulties, she could provide additional instructional strategies to overcome their difficulties (e.g., daily life examples, analogies, etc.). For example, as she predicted, some students thought that the activation energy is a not a requirement for exothermic reaction. During the instruction, one of the student said

Student: Exothermic reactions give energy. Why do they need activation energy?

Teacher: Please, think about burning a piece of paper or burning of natural gas. Both of them are exothermic reaction. What do we use to burn it?

Student: A match or spark.

Teacher: Yes. Because we need energy to initiate a reaction. The activation energy is the minimum amount of energy required to initiate a chemical reaction. If the reactant molecules do not have minimum activation energy, they do not produce the products.

She sensed that some students had a misunderstanding that was activation energy is a not a requirement for exothermic reaction. In order to address their misconception, she asked questions related to daily life. This discussion led the students to comprehend that the activation energy is necessary for all reactions to produce reactants. In the weekly post-interview, Simge said that "They have usually this misconception. They

do not think that exothermic reactions needs activation energy in order to initiate a reaction. Therefore, I gave daily life examples. I think they undersood it.” This example showed that Simge’s teacher efficacy appeared to play a role in her use of knowledge of learner and instructional strategies and the constructing the interaction between them.

**4.9. All teachers taught the same topics with similar lesson plans and same instructional materials; however, they differed in terms of how effectively they connect the PCK components.**

All teachers taught the reaction rate and chemical equilibrium topics with the same instructional materials and similar lesson plans. However, they differed in terms of how effectively they interact the PCK components in their teaching segments even if they used the same instructional materials. For instance, all teachers planned to use the same demonstration to show the effect of surface area on reaction rate; however, the effectively use of this topic-specific activity showed differences among teachers. During the instruction, Betül first explained the effect of surface area on reaction rate. She stated that “If we make the pieces of the reactants smaller, we increase the number of particles on the surface which can react. This makes the reaction faster. As we increase the surface area, the reaction rate increases.” (Betül, observation of the instruction, reaction rate) After this explanation, she started to make the demonstration. She put some flour on a plate and tried to burn it. Only the surface of the flour burned. After a few seconds, it went out. She stated that the contact surface area is small. Then, she stated that let’s increase surface area. In order to increase the surface area, she used a straw and blew the flour to the flame of Bunsen burner with the straw. They observed a very big flame. She stated that she increased the surface area and it burned. Then, she explained the reason of the observation without taking students’ ideas. She stated that as we increase the number of particles on the surface which can react, reaction rate increases (Betül, observation of the instruction, reaction rate). However, she could have asked what students expect and take their reasons. After the observation of the demonstration, she could

have made a whole class discussion. As a result, it can be inferred that her didactic science teaching orientation prevented her from using this topic-specific activity effectively. This topic-specific activity [knowledge of instructional strategy] was used only for verification to show the relationship between reaction rate and surface area [knowledge of curriculum]. In the post interview about the instructions, she provided evidence for this interaction. I asked:

Researcher: Why did you prefer to use the burning of flour demonstration?

Betül: It is funny. This demonstration will remain in the students' mind and also attracts their attention. It was important that the students observed the effect of surface area on reaction rate (Betül, weekly post-interview, reaction rate).

Similarly, Simge first explained the effect of surface area on reaction rate. During the instruction, she stated:

When we decrease particles size, we increase the surface area. As we increase the surface area, we increase the number of particles which collides each other at the same time. Thus, we increase the reaction rate. When we decrease particles size, we increase the surface area of the substances. By the way, we increase the rate of reaction. You are always confusing the meaning of decreasing the particle size and increasing the surface area. Actually, they have the same meaning. In the exams, you are writing wrong them. Please, be careful (Simge, observation of instruction, reaction rate).

Based on her previous teaching experience, she warned the students about the same meaning of decreasing the particle size and increasing the surface area. However, before warning them, she did not take her students' ideas. She preferred to directly warn them without checking whether they had a misunderstanding or not. Actually, she could have taken the students' ideas. It can be inferred that similar to Betül, Simge's didactic science teaching orientation inhibited the use of her knowledge of learner effectively. Then, she asked the students which one dissolves faster, granulated sugar or lump of sugar. Students answered as granulated sugar and could explain the reason why granulated sugar dissolves faster. In this point, she effectively

used her knowledge about students' pre-requisite knowledge. Then, she started to prepare the same demonstration as Betül made. She explained what she would do and what they would observe at the each steps of the demonstration. She put some flour on a plate and tried to burn it. She said

You are sensing a soft smell and only the particles on the surface of the flour burned, because the surface area is small. Only the particles on the surface of the flour gave a reaction. When we use a straw and blow the flour to the flame of Bunsen burner with the straw, you will observe a big difference (Simgе, observation of instruction, reaction rate).

Then, she blew the flour to the flame of Bunsen burner with the straw. The students observed the same things that their teacher told them before. However, she could have asked what students expect and take their reasons. Similar to Betül, her didactic orientation prevented the use of a topic-specific activity effectively. She did not let her students make a bridge between the surface area and reaction rate. This topic-specific activity [knowledge of instructional strategy] was only used for verification to show the relationship between reaction rate and surface area [knowledge of curriculum]. In the weekly post-interview, I asked:

Researcher: Why did you prefer to use the burning of flour demonstration?

Simgе: It is a funny demonstration. I wanted to show what happens when we increase surface area. This demonstration provides them to observe the things [the effect of surface on rate of reaction] that I explained them verbally (Simgе, weekly-post interview, reaction rate).

Finally, Burak implemented the same demonstration using a more student-centered approach. Before explaining the relation between surface area and rate of reaction, first he asked his students that:

Burak: We mentioned about dissolving sugar at 9<sup>th</sup> grade level. Which one dissolves faster, granulated sugar or lump of sugar?

Student: Granulated sugar

Burak: Why?

Student: Because of the increase in the surface area.

Burak: Contact surface area of the particles increases. Let's try to burn flour with different ways. Observe it. [He put some flour on a plate and tried to burn it. Then, he blew the flour to the flame of Bunsen burner.]What is the difference between these two states?

Student: We increase the surface area when you blew the flour. [Then, he initiated a whole class discussion].

Burak: The difference is that we increase the surface area of flour that contact with flame. (Burak, observation of the instructions, reaction rate)

In light of his academic-rigor science teaching orientation, he provided a class environment in which students were challenged to make a relationship between surface area and reaction rate by using the demonstration. He effectively integrated his knowledge of learner, curriculum and topic-specific activities. In the weekly post-interview, I asked:

Researcher: Why did you prefer to use the burning of flour demonstration?

Simge: That demonstration draws their attention. In addition, I expected them to comprehend that concept [effect of surface area on reaction rate]. I expected them to make a relationship between the concept and their observations. With this demonstration, I expected them to make inference based on their observations (Burak, weekly-post interview, reaction rate).

In another example, I observed that Betül and Burak differed in terms of how effectively interplay knowledge of learner and instructional strategies. I observed that in Betül's and Burak's teaching of chemical equilibrium, the students had difficulties in understanding the difference between equilibrium constant ( $K_c$ ) and reaction quotient ( $Q_c$ ). Betül and Burak tried to remedy this difficulty with different ways. In Betül's class, some of the students did not comprehend the difference between equilibrium constant ( $K_c$ ) and reaction quotient ( $Q_c$ ). When she realized their difficulty, she explained that part again in a teacher-centered approach and warned them not to forget the difference between them. Then, she wrote a question on the blackboard related to the calculation of reaction quotient ( $Q_c$ ), and prediction of the direction of the reaction to reach equilibrium. Then, she solved the question herself

without giving time to students for thinking about and solving the question. She explained how she solved the question and predicted the direction of the reaction in a teacher-centered approach. In the post-interview about the instruction, we talked about that instruction and Betül stated that

Some of the students had difficulties in understanding reaction quotient ( $Q_c$ ). I think that it has not resolved yet. They think only the time that the system reach equilibrium and make calculations for the equilibrium. However, they could not interpret the given data before the system reach equilibrium at any time. They did not understand how they used reaction quotient ( $Q_c$ ). I think it takes some time. We should perform extra exercises (Betül, weekly post-interview, reaction rate).

Although Betül realized the students' difficulty, she did not effectively use her instructional strategy [solving the question] to overcome their difficulty. It can be inferred that she did not interact knowledge of learner and instructional strategy effectively.

Similarly, while Burak was teaching reaction quotient ( $Q_c$ ), his students also had difficulties in understanding the difference between equilibrium constant ( $K_c$ ) and reaction quotient ( $Q_c$ ). However, different than Betül, he used an analogy to help them. During the instruction, Burak explained reaction quotient as

Burak: Reaction quotient is a value that is used to identify the given reaction at equilibrium or not. Also, it is used to find the direction of the reaction to reach equilibrium. If reaction quotient ( $Q_c$ ) equals to equilibrium constant ( $K_c$ ), this means that reaction is at equilibrium. If reaction quotient ( $Q_c$ ) is smaller than equilibrium constant ( $K_c$ ), in which direction does reaction quotient shift to reach equilibrium?

If  $Q_c = K_c$ , reaction is at equilibrium,

If  $Q_c < K_c$ , in which direction does reaction shift to reach equilibrium?

Student 1: Right to left.

Teacher: Why right to left?

Student 1: I think both two ways is possible because it is reversible.

Teacher: In this situation ( $Q_c < K_c$ ), does the reaction is at equilibrium?

Student 2: No, it does not.

Student 1: I did not understand it.

Burak: Please, listen. I have some rice and I wonder it is 1 kg or not. I use a balance scale to weigh the rice. I put 1 kg mass to left side of the scale, and the rice to right side [He also drew the scale on the board]. If both sides are at equilibrium, what can I say?

Student 1: The rice is 1 kg.

Teacher: Yes. If left side of the scale is up, what can I say?

Student 2: If left side of the scale is up, the rice is little. We should increase the rice.

Teacher: In order to make it 1 kg, I have to add rice. Now, assume that the equilibrium constant is 2 for a chemical reaction. At any time, I wonder that the reaction is at equilibrium or not. To decide this, I calculate reaction quotient ( $Q_c$ ) and decide it is equal to 2 or not and predict to the direction of the reaction to reach equilibrium. Assume that reaction quotient ( $Q_c$ ) equals to 1.5. In which direction does the reaction shift in order to reach equilibrium?

Student 3: Reaction shifts to the right.

Teacher: When we calculate the reaction quotient ( $Q_c$ ), we can decide the reaction is at equilibrium or not. Could I explain it?

Students: Yes.

Teacher: Let's solve several questions. (Burak, chemical equilibrium, observation of instructions)

It should be noted that at the beginning of chemical equilibrium topic, he used the scale example, but he emphasized the difference between static and dynamic equilibrium in order not to cause a misconception. He stated that

Teacher: Why do we use scale?

Student: It is used for measuring mass.

Teacher: You put something on one of side of the scale. If both sides have the same masses, you say that they are at equilibrium. What does the meaning of

“they are at equilibrium”? Both sides of the scale have equal masses. However, do not forget that the equilibrium that we learn in this chapter and the equilibrium of the scale are different from each other. One of them is static equilibrium and the other one that we learn in this chapter is dynamic equilibrium. The process in dynamic equilibrium continues in both directions on the contrary to static equilibrium.

After giving the analogy, he wrote a question on the board and gave time to students for solving the question. After a while, he wanted one of the students who did not understand the concept to solve the question. In the weekly post-interview, he stated that “I used that analogy for the first time. The students did not understand reaction quotient ( $Q_c$ ). That analogy came to my mind at that moment. I think they comprehended it [reaction quotient]” (Burak, weekly post-interview, chemical equilibrium).

As a conclusion, in both of Betül’s and Burak’s classes, the students had difficulties in understanding the difference between reaction quotient and chemical equilibrium, and the teachers chose different ways to help them. It was obvious that even though all the teachers taught the same topics with similar lesson plans and same instructional materials, they differed in terms of how effectively they connect the PCK components.

#### **4.10. Summary of the Results**

In this study, the nature of the interactions among PCK components of novice and experienced chemistry teachers in the teaching reaction rate and chemical equilibrium were examined. Moreover, what extent teaching experience is related to the interactions among PCK components regarding these two topics were explored. The main findings of this study are as below;

The novice teacher’s orientations towards science, in contrast to the experienced teachers, were much broad and non-specific, which impeded the connections among the components. There were much more differences between the novice teachers’ ideal and observed science teaching orientations than that of

experienced teachers. This ambiguity influenced the novice teacher's interactions between science teaching orientations and the other PCK components. In her PCK maps for both topics, science teaching orientation did not have any link with knowledge of assessment and learner components. Different from the novice teacher, the experienced teachers utilized their distinctive science teaching orientations and the remaining PCK components intensively. Therefore, they had much more connections and coherence among all components, regardless the topic, than that of the novice teacher.

The integration of the PCK components was idiosyncratic and topic specific. The teachers' PCK Maps differed from each other. Each teacher's PCK Map showed variances for the two topics. All teachers had more interplay in reaction rate topic than chemical equilibrium topic in total. The experienced teachers demonstrated more coherently structured PCK Maps for both topics than the novice teacher. The experienced teachers were able to utilize and relate all components whereas the novice teacher did not make all connections among PCK components. The most and the least frequent interactions among PCK components showed differences between the topics for the same teacher. There were also differences in both number and kinds of interactions among sub-components of PCK for each teacher in different topics. Burak could make much more different types of interactions among sub-components of PCK than the other teachers. All these findings might be resulted from the idiosyncratic nature and topic-specificity of the integrations among the PCK components.

The novice teacher's PCK maps were fragmented while the experienced teachers' PCK maps were integrated. The novice teacher rarely integrated science teaching orientations and knowledge of assessment into their PCK. In her teaching reaction rate and chemical equilibrium, she could not link science teaching orientations with knowledge of assessment and learner. In addition, in her teaching reaction rate, she could not link knowledge of assessment with instructional strategies. Different from the novice teacher, the experienced teachers could utilize all PCK components and integrate them coherently. All PCK components informed

each other many times in their teaching sessions; this was not the case for the novice teacher.

Knowledge of learner, knowledge of curriculum and knowledge of instructional strategies were central in the interplays of all teacher maps. In other words, all teachers frequently integrated knowledge of learner, curriculum and instructional strategies into their PCK. The interactions among those three components were the strongest among all interactions in the PCK maps. Additionally, the most experienced teacher, Burak connected reaction rate and chemical equilibrium much more frequently both to the topics taught in previous years (e.g., gases, energy and bonding, etc.) and to topics taught within the same grade (e.g., enthalpy, endothermic reaction, etc.) while planning and enacting their teachings than the other teachers. On the other hand, none of the teachers bring their knowledge of subject-specific strategies (e.g., learning cycle, inquiry) into play while teaching both topics. Their teaching was generally based on lecturing; however, they enriched their instruction with topic specific activities and representations.

The novice and experienced teachers displayed different levels of complexity in their interactions among PCK components. Some of the interactions were very simple that one PCK component connected the other one, while some others were complicated including more than two different components of PCK. In general, the interactions in Betül's teaching were so simple that one PCK component was related to the other one. In general, Burak's teaching segments in reaction rate and chemical equilibrium topic had much more complicated interactions than the other two teachers.

The experienced teachers had much more two-way interactions among PCK components than the novice teacher. In Burak's and Simge's teaching segments for both topics, the interactions between instructional strategies and assessment, curriculum and assessment, and curriculum and instructional strategies components showed one-way direction. In Burak's and Simge's teaching segments, the interactions between learner and assessment, learner and curriculum and learner and instructional strategies showed two-way direction. In all teaching segments of Betül,

the interactions between instructional strategies and assessment, curriculum and assessment, and curriculum and instructional strategies, learner and assessment, learner and curriculum showed one-way direction. Two-way interaction was only observed between knowledge of learner and instructional strategies.

The experienced teachers were more successful than the novice teacher in translating their knowledge into practice in terms of the integration among knowledge components. Specifically, Burak could mostly translate the connections among PCK components from knowledge into practice.

Teacher self-efficacy appeared to play a role in their use of PCK components and constructing interactions among them. In Betül's teaching segments, teacher efficacy appeared to play a role in the enactment of PCK. She partially believed her capability to identify students' difficulties and misconceptions, and to use alternative strategies or explanations to deal with them. She could not enact them effectively in actual classroom. Therefore, limited interaction between knowledge of learner and instructional strategies was observed in Betül's teaching the topics when compared with that of the experienced teachers. The experienced teachers believed their capability to perform their PCK effectively; therefore, they could frequently integrate and enact the components of PCK into their actual classrooms. They believed their capability to use different instructional strategies in order to overcome the students' difficulties and misconceptions.

All teachers taught the same topics with similar lesson plans and same instructional materials; however, they differed in terms of how effectively they connect the PCK components. All teachers differed in terms of how effectively they interact the PCK components in their teaching segments even if they used the same instructional materials and similar lesson plans. The most experienced teacher, Burak, connected PCK components much more effectively than did the other teachers.



## CHAPTER 5

### DISCUSSION, CONCLUSION AND IMPLICATIONS

In this chapter, I will initially discuss the results of the present study by comparing and contrasting with the other studies on PCK in the literature. Then, I will present my conclusions based on the results derived from the study. Finally, I will present implications and suggestions for preservice and in-service teacher education and for science education research.

#### 5.1. Discussion

This study aims to portray the interactions among PCK components that shape the teaching of novice and experienced chemistry teachers working at the same high school. In the following parts, the results of the study consisting of nine assertions regarding the interaction among PCK components are discussed by comparing and contrasting with the other studies on PCK in the literature.

##### **5.1.1. Discussion of the results regarding the assertion that the novice teacher's orientations towards science, in contrast to the experienced teachers, were much broad and non-specific, which impeded the connections among the components**

The results of this study showed that there were much more differences between the novice teachers' ideal and observed orientations than those of the experienced teachers. The novice teacher emphasized that discovery, guided-inquiry, and everyday coping were among the central goals that represent her teaching reaction rate and chemical equilibrium. However, she could not reflect these goals on her teaching sessions that I observed. These findings served as evidence for the fact that the novice teacher's orientations towards science were vague, broad and non-specific (Friedrichsen & Dana, 2003). The novice teacher mentioned about these

discrepancies during the interview, and stated that implementing an instruction based on discovery and inquiry required teaching experience. Lack of teaching experience might impede the novice teacher's ideal orientation transfer into her teaching practice and the interactions between orientations and other components. Teachers develop their PCK in their actual classrooms, because working with learners enables them to learn about student difficulties, misconceptions and prerequisite knowledge about a specific topic, and they also learn which instructional strategies work well for teaching specific topics (Grossman, 1990).

Moreover, Betül's PCK maps for both reaction rate and chemical equilibrium evidently revealed that she could construct the least of links between science teaching orientations and the other components. Her science teaching orientations did not inform her learner and assessment knowledge. It can be inferred that her broad and non-specific view of orientations may inhibit the interactions between orientations and the other components. Several studies also provided consistent findings about the fact that teachers' science teaching orientations might inhibit the interactions among PCK components (Friedrichsen et al., 2009; Park & Chen, 2012; Aydin & Boz, 2013; Aydin et al., 2015; Demirdöğen, 2016). In addition to the ambiguity of the novice teacher's orientations towards science, Betül mostly had didactic science teaching orientation which shaped her instructional decisions and implementation of them. Although she had peripheral goals (e.g., process), her central didactic orientation might have power to influence her instructional decisions by inhibiting the other orientations' influence. For instance, she used laboratory activities, but only for verification of the chemistry concepts. These findings are compatible with the research stating that beginning teachers have simplistic views of teaching and learning, and explain ideas through lectures and verification laboratories (Friedrichsen et al., 2009). In addition, the novice teacher was knowledgeable about some of the difficulties of the students in reaction rate and chemical equilibrium. However, in order to overcome these difficulties, she preferred to warn them and re-explained the confusing parts. It can be inferred that her strong didactic orientation might filter her instructional decisions and implementation of

them as well as the interactions between science teaching orientations with learner and instructional strategies. These findings support the view that teachers' beliefs serve as filters and determine how specific PCK components are used in teaching practice (Magnusson et al., 1999; Abell, 2008; Brown et al., 2013; Demirdögen, 2016). Similarly, Park and Chen stated that a strong didactic orientation significantly controlled knowledge of instructional strategies and consequently isolated this component which impeded it from connecting with other components. The novice teacher's broad and traditional view of teaching and learning might be resulted from her background experiences as a K-12 student and a preservice teacher (Brown et al., 2013). In addition, it seems that her 3-year of teaching experience was not enough to develop her science teaching orientations.

On the other hand, the experienced teachers used their distinctive science teaching orientations and the remaining PCK components coherently, in both topics. Unlike the novice teacher, the results showed that there was a little difference between the experienced teachers' ideal and observed orientations. The only difference between ideal and observed orientations of Burak was discovery. The differences between ideal and observed orientations of Simge were discovery and guided-inquiry. The experienced teachers provided evidence about these conflicts during the post-interviews, and underlined that both loaded curriculum and high stakes testing were a significant barrier for them to attain their goals. Apart from these differences, their ideal orientations were consistent with the observed ones. Although the novice and experienced teachers held didactic science teaching orientations focusing on transmitting information to the learners, their ways of teaching these topics showed differences, which is similar to the findings of Mohlouoa et al. (2013). The experienced teachers, especially Burak, enriched their instructions with analogy, demonstrations, illustrations, etc. in most of the cases. Moreover, the experienced teachers gained additional goals (e.g., everyday coping, conceptual change etc.) throughout their teaching profession. They could reflect their decisions on their teaching sessions that I observed. Unlike the novice teacher, both experienced teachers could construct the relationships between science teaching

orientations and the other components. These results provided evidence for the fact that the experienced teacher's orientations towards science were much more distinct than that of the novice teacher. Furthermore, their science teaching orientations influenced their teaching practice by shaping curriculum, assessment, learner and instructional strategies knowledge in most of the cases. These findings are consistent with the literature (Magnusson et al., 1999; Brown et al., 2013; Demirdögen, 2016) which emphasized that teachers' science teaching orientations had a pivotal role in the growth of their PCK.

All these findings infer that teaching experience may have a role on the teachers' science teaching orientations. The more teaching experience they gained, the more distinctive orientations they had. This finding is not compatible with the view that prior teaching experience made little difference in science teaching orientations between the inexperienced group and the group with 2-year teaching experience (Friedrichsen et al., 2009). This finding was acceptable knowing that teachers' orientations are robust and resistant to change (Friedrichsen et al., 2009; Brown et al., 2013). However, it should be noted that improving a more sophisticated science teaching orientation for teachers is a prerequisite to advancing other PCK components (Brown et al., 2013).

### **5.1.2. Discussion of the results regarding the assertion that the interplay of the components was idiosyncratic and topic-specific**

Analysis of PCK maps indicated that the interplay of the components was idiosyncratic and topic-specific. While the idiosyncratic nature and topic-specificity of PCK have been empirically supported by many scholars (Grossman, 1990; Van Driel et al., 1998; Loughran, Mulhall, & Berry, 2008), my results, however, recommended that those features not only stem from different PCK components involved in a teaching fragment but also different interactions of the components and sub-components included in a teaching fragment. Although this corresponds with the conclusions of previous research (Park & Chen, 2012; Aydin & Boz, 2013), to the best of my knowledge, the interplays among sub-components of PCK have not yet

been fully explored. The explicit analysis among sub-components is very important in order to compare and contrast the teachers' integration of PCK components in detail, as well as to capture and portray idiosyncratic nature of these integrations.

In this study, the findings indicated that idiosyncratic and topic-specific nature of the interactions of PCK components was observed since all participants' PCK maps showed differences for the teachings on reaction rate and chemical equilibrium. In addition, each teacher's PCK maps for each topic displayed differences. These findings confirm Park and Chen (2012) who suggest that the topic-specificity can be link to not only which components compose a teacher's PCK for a specific topic but also how and what degree those components interplay with each other. Moreover, the findings showed that the experienced teachers had much more coherently structured PCK maps for both topics than the novice teacher. Different from the experienced teachers, the novice teacher's PCK maps in both topics had some missing parts (e.g., there was no connection between orientation and assessment). In addition, the frequency for each link between any two PCK components was mostly different from each other. The use of any PCK component showed differences for each teacher as well as for each topic. Furthermore, the results revealed that the most and the least frequent interactions among the components, and the number and kinds of interactions among sub-components of PCK showed differences for each teacher in different topics. The most experienced teacher, Burak, possessed much more and different kinds of interactions among sub-components of PCK than Betül and Simge. All these findings might result from the idiosyncratic nature and topic-specificity of the interactions among the components (Park & Chen, 2012; Aydin & Boz, 2013). For all participants in this study, the context, the topics, and the lesson plans were the same. Additionally, their educational backgrounds were similar. Therefore, the participants' level of teaching experience, an important source of PCK, might shape the idiosyncrasy of the teachers' PCK integration. In addition to teaching experience, science teaching orientations, personal characteristics and characteristics of students might shape the idiosyncrasy of teachers' PCK (Park & Oliver, 2008a).

Moreover, the findings showed that novice and experienced teachers integrated the components into their PCK much more in reaction rate than chemical equilibrium. The novice teacher, Betül provided evidence that her students possessed many difficulties in understanding terms and explanations in chemical equilibrium; therefore, teaching this topic was challenging for her. Simge, the experienced teacher, also expressed that relating chemistry to daily life in chemical equilibrium topic was more difficult for her than reaction rate. These findings are consistent with the view that chemical equilibrium is one of the most complex topics in chemistry; therefore, most teachers and students themselves struggle with some concepts of chemical equilibrium (e.g., Van Driel et al., 1998; Tyson, Treagust & Bucat, 1999; Voska & Heikkinen, 2000; Cakmakci, 2010). In addition, its content is very abstract and it requires a high degree of connections with other topics in chemistry as well as content and terminology of specific explanations (Tyson, Treagust & Bucat, 1999). It can be inferred that in order to learn chemical equilibrium, learners need to have far more prerequisite knowledge. In a similar vein, teachers are required to have much more knowledge about vertical (e.g., gases, bonds, etc.) and horizontal curriculum (e.g., reaction rate, chemical reactions and energy, etc.) to fulfill learners' needs. As a result, the nature of topic is an indicator on how and to what extent components interact with each other, which is also supported by Park and Chen (2012).

### **5.1.3. Discussion of the results regarding the assertion that the novice teacher's PCK maps were fragmented while the experienced teachers' PCK maps were integrative**

The findings indicated that the novice teacher's PCK maps, in contrast to the experienced teachers, were fragmented since there were some missing interactions among the components. In addition to the existence of each PCK component, the degree of the interactions and coherence among the components showed the level of a teacher's PCK (Park & Oliver, 2008a; Friedrichsen et al., 2009). The appropriate interplay among the components might be the most critical factor for the teachers' successful teaching (Fernandez-Balboa & Stiehl, 1995). From this point of view,

although the novice teacher had separate PCK components, she could not utilize them in harmony in her teaching reaction rate and chemical equilibrium. This finding supported the view that the novice teachers had a limited PCK level in spite of their science backgrounds (Lee et al., 2007). Therefore, the inadequate level of the novice teacher's PCK may cause fragmented integration of PCK components. For instance, Betül could not connect science teaching orientations with learner and assessment. She showed little evidence of interactions of science teaching orientations with curriculum and instructional strategies. These findings can be anticipated because her broad, non-specific and strong didactic science teaching orientations presented barriers to forming connections among all PCK components. Moreover, the novice teacher showed a limited repertoire of topic-specific knowledge about learners, instructional strategies and assessment, which also resulted in fragmented PCK maps.

On the other hand, the experienced teachers' PCK maps were integrative, because they could utilize all PCK components coherently. This result can be anticipated because the experienced teachers' knowledge bases were more extensive than those of the novice teacher. Therefore, they could use and link all PCK components to each other. Based on their teaching experiences, the experienced teachers, in contrast to novice teacher, easily attempted to tailor their instructional strategies to meet the students' learning needs in reaction rate and chemical equilibrium. These findings were similar with the other studies (e.g., Clermont et al., 1994) revealing that the experienced teachers recognized the students' difficulties, sources of these difficulties and knew the ways of addressing them much more frequently than did the novice teachers. Similarly, Friedrichsen et al. (2009) compared preservice teachers with no teaching experience and full time teachers with 2 years teaching experience. Their findings indicated that the teachers showed evidence of interplay among some components, but the preservice teachers did not. They supported that teaching experience promoted the interplay of the components. This finding is also similar to the studies (Brown, Abell and Friedrichsen, 2008; Brown et al. 2013) advocating that as preservice teachers gain more teaching experience, the interactions among PCK components develops. Teaching experience

reinforces the growth, choice and utilization of PCK (Gess-Newsome, 1999). On the other hand, this finding is inconsistent with the research stating that the experienced teachers could not integrate some PCK components while teaching redox reactions and electrochemical cells, which indicated that teaching experience was not enough to promote the integration of the components (Aydin & Boz, 2013). However, when the topic- and person-specificity of PCK are taken into account, this inconsistency among the different research seems natural.

#### **5.1.4. Discussion of the results regarding the assertion that the knowledge of learner, knowledge of curriculum and knowledge of instructional strategies were central in the interplays of all teacher maps**

The findings pointed out that knowledge of learner, curriculum and instructional strategies played an influential role in shaping the three teachers' PCK maps, because they frequently integrated them into their PCK. Regarding the teaching of reaction rate and chemical equilibrium, the most frequent interactions were observed among these three components; therefore, the interactions between them were the strongest among all interactions. Shulman (1986) conceptualized PCK as knowledge of learner and instructional strategies which were the key components of PCK and most scholars have agreed with him although their descriptions of PCK differ (Magnusson et al., 1999; Park & Oliver, 2008a). In this regard, the close connection between knowledge of learner and instructional strategies can be anticipated considering that teachers should know students' prerequisite knowledge and difficulties in a specific topic in order to compose instructional strategies (Magnusson et al., 1999). Therefore, the present study empirically supported that knowledge of learner and instructional strategies were the key components of PCK, and they were influential in shaping the teachers' PCK maps (Park & Chen, 2012; Aydin & Boz, 2013). At this point, Park and Oliver (2008a) provided a consistent finding related to knowledge of learner. They asserted that "...teachers' capacity to "read" students is essential to their PCK development because students' responses

can influence teaching practices only when a teacher is aware of their significance” (italic is original, p.279).

Additionally, knowledge of curriculum was another most frequent component in the present study. This finding is inconsistent with the research stating that curriculum component is less frequently connected to other PCK components (Park & Chen, 2012; Aydin & Boz, 2013). However, research also has provided evidence that curriculum knowledge is probably the tool with the highest potential for improving teacher knowledge (Arzi & White, 2007). Arzi and White (2007) reported that “the required school curriculum is the single most powerful factor affecting teacher content knowledge, serving as both knowledge organizer and source” (p.230). According to the analysis of interactions among sub-components of curriculum knowledge, all participants referred to curriculum mostly to identify the goals and objectives in order to cover the topics. Of the three teachers, Burak showed greater awareness than the other teachers in the sequence of the curriculum within a grade and across grades while planning and enacting his teachings. He had a more sophisticated understanding of curriculum than Betül and Simge. Similarly, Friedrichsen et al. (2009) found that the teachers had a broader view of curriculum knowledge than the preservice teachers. This evident difference may stem from the teachers’ different levels of teaching experience, because teaching experience reinforces the development and use of PCK as also claimed by Gess-Newsome (1999). Moreover, Sickel (2012) concluded that teaching experience helped the teachers develop their knowledge of horizontal curriculum.

On the other hand, none of the participants brought their knowledge of subject-specific strategies (e.g., learning cycle, inquiry, etc.) into play while teaching both topics. This implies that teaching experience alone did not make any difference in implementing subject-specific strategies regarding teaching these two topics. This finding aligns with the research reporting that both preservice teachers and teachers had limited knowledge of subject-specific instructional strategies (Friedrichsen et al., 2009), and that the experienced teachers did not perform any subject-specific instructional strategies during their instructions (Aydin et al., 2014). Instead of using

subject-specific instructional strategies, they presented the content didactically. This could be linked to several factors. First, because of their science teaching orientations which directly shape their instructional decisions, they might prefer to use didactic teaching (Magnusson et al., 1999; Friedrichsen et al. (2009). Their strong didactic science teaching orientation might filter the teachers' instructional decisions (Friedrichsen et al., 2009), which resulted in less room for the influence of other orientations on their subject-specific instructional decisions. It should be noted that the central goals are very important and resistant to change (Haney & McArthur, 2002). Didactic science teaching orientation was one of the central goals of all the teachers. Second, teachers might have difficulties while implementing subject-specific strategies (Settlage, 2000, Brown et al., 2013). For example, Brown et al. (2013) stated that during teacher preparation program, prospective secondary science teachers learned about, experienced, and designed 5E instructional sequences in science methods courses; however, they did not use 5Es in their internship classrooms. They were unable to implement the 5Es in their teaching. Third, the choice of instructional strategies can also be influenced by national curriculum and high stakes testing (Haney & McArthur, 2002). During the interviews, the teachers stated that the need to cover the entire chemistry curriculum and high stakes testing influenced their instructional decisions. In conclusion, all these factors appeared to be obstacles to the implementation of the subject-specific instructional decisions.

#### **5.1.5. Discussion of the results regarding the assertion that the novice and experienced teachers displayed different levels of complexity in their interactions among PCK components**

The findings of this study revealed that the level of complexity among the components might differ. In other words, some of the interactions were simple while some of them were complex. This finding might result from the nature of PCK which is that the interplays among PCK components do not occur as a linear process; instead, multiple variations may appear concurrently (Fernandez-Balboa & Stiehl, 1995). Of the three teachers, the most experienced teacher, Burak, had much more

complex interactions than that of the other teachers. He integrated two or more PCK components into his PCK in most of his teaching segments.

Although research has revealed that PCK components interact with each other in a highly complex way (Magnusson et al., 1999; Park & Oliver, 2008a), very few empirical studies have investigated the level of integration complexity among the components (Aydin & Boz, 2013). Aydin and Boz (2013) examined the complex interactions among PCK components of experienced teachers and asserted that the level of complexity of integration might vary. Different from the results of this study, I examined the complexity of interactions among the PCK components of novice and experienced teachers. I concluded that the interactions in the novice teacher's teaching were much simpler than that of the experienced teachers. The experienced teachers' instructions revealed much more complex interactions consisting of more than two components than the novice teacher's. This could be linked to their teaching experience, since teaching experience promoted the integration of the components (Brown et al., 2008; Friedrichsen et al., 2009; Brown et al., 2013). Although this study put an effort to understand the complex nature of integration among PCK components, still there is a need for research on the complex nature of interactions among the components (Magnusson et al., 1999; Park & Chen, 2012).

#### **5.1.6. Discussion of the results regarding the assertion that the experienced teachers had much more two-way interactions among PCK components than the novice teacher**

The findings showed that directions of the interactions among PCK components were one way or two-way. Specifically, in the experienced teachers' (Burak and Simge) teaching segments for both topics, the interactions between instructional strategies and assessment, curriculum and assessment, and curriculum and instructional strategies showed one-way directions. However, the interactions between learner and assessment, learner and curriculum, and learner and instructional strategies showed two-way directions. On the other hand, in the novice teacher's teaching segments for both topics, the interactions among all PCK

components, except the interaction between learner and instructional strategies were one-way. It is evident that the experienced teachers had much more two-way interactions among the components than the novice teacher. The novice teacher was mostly able to connect PCK components in one-way direction. For instance, her knowledge of assessment always informed her knowledge of learner. There was not any evidence for the interaction in which her knowledge of learner informed her knowledge of assessment. It seems reasonable; because throughout interviews she provided evidence that she was unfamiliar with common students' difficulties and misconceptions. She expressed that after the assessment of students' understanding, she realized their difficulties and misconceptions. As a result, she did not possess all components and sub-components of PCK, which might influence her use of PCK components simultaneously. Therefore, it seems plausible that no example could be found revealing that her knowledge of learner informed her knowledge of assessment. The teachers developed different components and sub-components of PCK over time. Therefore, the differences in the way of the interactions seem reasonable when the different levels of teaching experience were taken into consideration. In a study conducted by Henze et al. (2008), they reported that the teachers' development of PCK over the years were qualitatively different in the connections of PCK components.

On the other hand, it appeared that there were some similarities in the directions of the interactions among PCK components between novice and experienced teachers. In all teachers' teaching segments, where the teachers linked their instructional strategies with assessment knowledge, instructional strategies always informed their assessment knowledge (one-way direction). Additionally, in all teachers' teaching segments, curriculum knowledge always informed their instructional strategies and assessment knowledge (one-way). A common two-way interaction was observed between knowledge of learner and instructional strategies. However, the close analysis among sub-components showed that there were some differences in the interactions among sub-components of these components. For instance, in Simge's teaching segments, knowledge of goals and objectives most

frequently informed how to assess sub-component. In Burak's teaching segments, knowledge of goals and objectives most frequently informed what to assess sub-component. It is expected to observe similarities as well as differences in the directions of the interactions in different topics for different teachers. This could be linked to the person- and topic-specific nature of PCK (Hashweh, 2005). For instance, in a study examining experienced chemistry teachers' PCK, Aydin (2012) observed that the interactions between learner and assessment, and curriculum and learner were two-way. On the other hand, the interactions between instructional strategies and learner, curriculum and instructional strategies, and assessment and instructional strategies were one-way. The experienced teachers of the present study mostly showed similar directions of the interactions in the study of Aydin (2012). To the best of my knowledge, there has not been any other research to present the nature of PCK in terms of the direction of the interactions among the components and sub-components. Therefore, the present study provides empirical evidence for understanding the complex nature of the PCK integration in terms of the directions of PCK components' interactions.

#### **5.1.7. Discussion of the results regarding the assertion that the experienced teachers were more successful than the novice teacher in translating their knowledge into practice in terms of the integration among PCK components**

The findings indicated that in some cases, even if the teachers had the knowledge, they could not translate their knowledge into practice. For instance, the teachers had some goals and beliefs concerning teaching science (e.g., guided-inquiry, discovery); however, they could not transfer these beliefs into practice. Moreover, they could not translate their subject-specific knowledge from knowledge into practice. On the other hand, they were able to translate their topic-specific instructional strategies into practice. Considering the nature of PCK which is that "...PCK is both an external and internal construct, as it is constituted by what a teacher knows, what a teacher does, and the reasons for the teacher's actions"

(Baxter & Lederman, 1999, p.158), this finding does not seem surprising. The translation of teachers' knowledge into classroom practice is an important feature of PCK and this forces us to observe actual teaching fragments (Baxter & Lederman, 1999). Additionally, when the PCK definition, which is based on teachers' understanding and their enactment (Park & Oliver (2008a), is taken into account, it seems plausible to observe some of the interactions at knowledge level, while others were translated from knowledge into practice. PCK growth incorporated knowledge acquisition and knowledge use. They were interrelated during instructional practices rather than following the sequence acquisition and enactment (Park & Oliver, 2008a).

Moreover, comparisons of connections among the components put forward that the experienced teachers were more successful than the novice teacher in translating the integration of PCK components from knowledge into their teaching practice. In other words, the experienced teachers could integrate the PCK components and enact them much more in the context of teaching reaction rate and chemical equilibrium than did the novice teacher. For an effective teaching, teachers should integrate the components and enact them within a context (Park & Oliver, 2008a). The enactment of PCK in a topic requires a teacher to interplay various PCK components (Park & Oliver, 2008a). Accordingly, the novice teacher's fragmented PCK might prevent her from translating the interactions of PCK components from knowledge into practice. It can be inferred that teaching experience might help teacher achieve translating integration of PCK components from knowledge into practice. Park and Oliver (2008a) supported that teachers should produce knowledge for a teaching based on their own experiences, and the strongest changes in teacher knowledge stem from experiences.

#### **5.1.8. Discussion of the results regarding the assertion that teacher self-efficacy appeared to play a role in their use of PCK components and constructing interactions among them**

The findings revealed that teachers' self-efficacy appeared to play a role in the teachers' use of PCK components and constructing interactions among them. The

experienced teachers relied on their own capability in performing their PCK effectively. Therefore, they could frequently integrate and enact the PCK components into their actual classrooms. For instance, they believed in their own capability to use different instructional strategies in order to address students' difficulties and misconceptions. Therefore, it can be inferred that their high teacher efficacy may have a role in frequent use of PCK components and the construction of interactions among them. Conversely, the novice teacher partially believed in her own capability to perform her PCK in an actual classroom. Therefore, she sometimes could not display her PCK effectively in an actual classroom. For example, she partially believed in her own capability to identify students' difficulties and misconceptions and to use alternative strategies or explanations to manage them. Therefore, it can be inferred that her low teacher efficacy may play a role in the limited interactions between knowledge of learner and instructional strategies. These findings also align with the research providing evidence for that teacher efficacy has a strong effect on teaching effectiveness and PCK (Knoblauch & Woolfolk Hoy, 2008; Park & Oliver, 2008a). Actually, there is a bidirectional relationship between PCK and teacher efficacy (Park & Oliver, 2008a). Moreover, Park and Oliver (2008a) advocated that PCK consists of two dimensions: understanding and enactment. At this point, teacher efficacy served as a conduit to transfer PCK from understanding into enactment. High teacher efficacy enables teachers to enact their understanding. "When the enactment was successfully performed, teacher efficacy was in turn increased" (Park & Oliver, 2008a, p.284). Furthermore, when it was asked, the experienced teachers (Simge and Burak) attributed their high teacher efficacy in the enactment of PCK components to their teaching experience. The novice teacher attributed her low teacher efficacy regarding PCK components to her inadequate teaching experience. It seems reasonable, because self-efficacy beliefs are developed through enactive mastery experience (Bandura, 1977). The mastery experiences acquired in the form of successful teaching is an important source of teacher efficacy (Mulholland & Wallace, 2001; Park & Oliver, 2008a).

Finally, this assertion also supports the idea that it seems plausible to view teacher efficacy as a component of PCK (Park & Oliver, 2008a; Gess-Newsome, 2015), because it plays a critical role in defining problems and determining teaching strategies to solve the problems (Park & Oliver, 2008a). Furthermore, this finding of the present study can also be explained by a recent model proposed by Gess-Newsome (2015). According to this model, teacher professional knowledge and skill (TPK&S) is relatively different from the one originally introduced by Magnusson et al. (1999). In the model of TPK&S, teacher orientations and beliefs such as teacher efficacy, motivation, and dissatisfaction are removed from the PCK construct and viewed as amplifiers or filters for classroom practice. Based this point of view, the role of teacher efficacy beliefs regarding the use of and establishing connections among PCK components appears to be plausible.

#### **5.1.9. Discussion of the results regarding the assertion that all teachers taught the same topics with similar lesson plans and same instructional materials; however, they differed in terms of how effectively they connect the PCK components**

All teachers taught the reaction rate and chemical equilibrium topics with the same instructional materials and similar lesson plans. However, they differed in terms of how effectively they integrate the PCK components into their teaching segments, even if they used the same instructional materials. The findings showed that the most experienced teacher (Burak) connected PCK components much more effectively than the other teachers (Simge and Betül). This result may stem from person-specific nature of PCK (Hashweh, 2005). The teachers' different levels of teaching experience may influence the effective integration of PCK components, because PCK can be improved through teaching experience (Lee et al., 2007). It can be inferred that as they gain experience, they might enhance robust PCK and enact their PCK effectively in an actual classroom. Moreover, as I discussed before, the teachers' didactic science teaching orientation might prevent them from integrating PCK components effectively (Friedrichsen et al., 2009; Park & Chen, 2012; Aydin &

Boz, 2013; Aydin et al., 2015; Demirdöğen, 2016). Teachers' science teaching orientations acted as a barrier to improve more sophisticated PCK (Brown et al., 2013).

## **5.2. Conclusion**

In this study, the nature of interaction among PCK components of novice and experienced chemistry teachers in the teaching reaction rate and chemical equilibrium were examined. Moreover, the role of teaching experience in the interactions among PCK components regarding teaching these two topics was investigated. The Park and Chen's pentagon PCK model was used for the analyses of the interactions among PCK components. Based on the analyses of the participants' PCK maps and the discussions of findings, the following conclusions can be made:

PCK is more than the sum of the essential components, and the coherent interactions among the components increase the quality of PCK. Moreover, the growth of a single component may not be enough for a change in teachers' practice because the teachers may not integrate that component into their PCK during practice. In addition, lack of coherence among PCK components can cause problems in using and developing PCK.

Science teaching orientations influence the teachers' PCK as well as the interactions of PCK components. The novice teacher's orientations towards science are broad and non-specific, which impedes the interactions of the PCK components. On the other hand, the experienced teachers use their distinctive science teaching orientations and the remaining PCK components coherently. It can be concluded that teaching experience has a role in the teachers' science teaching orientations. Lack of teaching experience prevents the novice teacher from transferring her ideal orientations into her teaching practice, and building the interactions between orientations and the other PCK components.

The interplay of PCK components is idiosyncratic and topic-specific. The idiosyncratic nature and topic-specificity of the interplay of PCK components stem from different PCK components' involvement in a teaching fragment and also

different interactions of the components and sub-components in a teaching fragment. Moreover, the teacher's level of teaching experience shapes the idiosyncrasy of the PCK integration.

The existence of each PCK component, the degree of the interaction and coherence among the components show the level of a teacher's PCK. The use of PCK components and a coherent integration among them are mainly influenced by teaching experience. The teachers gain topic-specific PCK in an integrative mode through their teaching experience. In other words, teaching experience appears to lead an increased level of integration of PCK components.

Knowledge of learner, curriculum and instructional strategies play an influential role in shaping the teachers' PCK maps, because they frequently integrate them into their PCK.

The interplays among PCK components do not occur as a linear process; instead, multiple variations may appear simultaneously. Additionally, teaching experience promotes sophisticated integration of the PCK components.

Teaching experience enable the teachers to connect the PCK components in two-way. Moreover, teaching experience helps the teachers translate integration of PCK components from knowledge into practice. Teaching experience has a powerful influence on effective integration of PCK components.

The teacher efficacy has a role in use of PCK components and the construction among them. A teacher with a high teacher efficacy frequently uses PCK components and connects them. In addition, teaching experience is influential on teacher efficacy.

### **5.3. Implications and Suggestions for Practice**

This study provides evidence for the lack of clarity about the nature of PCK, its components and interactions among components, and its development. Specifically, this study provides valuable information for the dynamics, complexities and directions of the interplays among components and sub-components of PCK in chemistry teaching. Therefore, not only understanding of chemistry teachers' PCK

but also understanding of how the interactions among PCK components will contribute to our overall understanding of what high quality science teaching looks like. All these findings may inform science teacher educators and policy makers.

For science teacher educators, the findings of this study imply a need to focus on developing the teachers' PCK and interconnectedness among the components in teaching specific topics within the same discipline. PCK demonstrates a dynamic nature, not static, and so teachers can improve their PCK over time (Fernandez-Balboa & Stiehl, 1995; Kind, 2009). If preservice teachers are supported to comprehend PCK as knowledge during teacher education programs, this may positively contribute to their professional development as novice science teachers. Therefore, preservice teacher education programs should provide opportunities for preservice teachers to be aware of PCK and develop their PCK as well as the integrations of the components. Professional coursework and disciplinary background are among the sources of PCK (Grossman, 1990). Therefore, during preservice teacher education courses, PCK construct, integration of the components, and its nature should be explicitly introduced to preservice teachers as a professional knowledge base for science teaching. For instance, in the courses related to methods of science teaching, preservice teachers should learn about PCK, its components and its nature. They should learn subject-specific and topic-specific PCK, what they explicitly mean and the difference between them. It should be emphasized that a teacher should possess different PCK for various subjects and topics. They should learn subject-specific instructional strategies for science teaching. Preservice teachers should be dissatisfied with their simplistic views of teaching and learning, and provided plausible ways to make teaching and learning more student-centered. In addition, these courses should provide opportunities for teachers to learn how to implement instructional strategies in different topics in order to overcome students' difficulties and misconceptions. After explicitly introducing PCK to preservice teachers, they should be expected to consider PCK components coherently while lesson planning and performing that plan. In these courses, it may be helpful to present CoRe as a lesson planning tool. Preservice teachers should learn how to use

CoRes while planning a lesson, and how each dimension of CoRe relates to PCK components. In addition, the components of PCK can be developed in different courses during teacher education. For instance, in an effort to develop knowledge of curriculum component of PCK, in the courses related to curriculum, PCK should be explicitly emphasized by encouraging preservice teachers to have awareness in the sequence of the curriculum within a grade and across grade levels. Moreover, some courses should be offered to preservice teachers in order to examine students' misconceptions, difficulties and necessary prerequisite knowledge in each topic within a discipline with the purpose of enhancing their knowledge of learner component of PCK. In a similar vein, during the courses related to instructional technology and material development, preservice teachers should be supported to develop topic-specific materials in specific topics, and consider how these materials are used to overcome students' difficulties and misconceptions. While doing these, the integration among PCK components should be supported as well. In the courses related to measurement and evaluation, the use of assessment knowledge and the integration of this knowledge with other components should be emphasized. For instance, while assessing student learning as related to stated goals, the interaction between assessment and curriculum should be emphasized. Moreover, in practice teaching courses, preservice teachers should develop their PCK, and design and experience instructions by using that knowledge much more effectively. Preservice teachers should be expected to use and enact their PCK in their teachings consciously. For that, microteachings should be used to observe how preservice teachers put their PCK into action as well as to develop their PCK. In these microteachings, they should manage students' difficulties and misconceptions, connect the topics within and across grades, and implement instructional and assessment strategies while planning and enacting their teachings simultaneously. Additionally, teachers' reflection upon their own teaching influences their PCK development. Therefore, during microteaching sessions, preservice teachers should find opportunity to reflect on their own PCK, to realize and discuss both weak and strong parts in their instruction considering PCK components and the integrations of them. They also

might be expected to draw their own PCK maps in order to visualize their own PCK integration. This provides them to realize the components that they have difficulty while interacting with other components. Instructors of these courses also should give feedback to preservice teachers focusing on how they effectively use their PCK as well as the integrations of the components. In addition to these, veteran teachers in cooperating schools should give feedback to their practice teachings performed in these schools considering the components of PCK. These teachings may be followed by reflective writings on weak and strong parts of their instructions considering PCK components and the interactions among. Moreover, educative mentoring may be provided to preservice teachers by instructor or teaching assistants of the course in order to improve their CoRe implementation, explicit use of PCK, and the integration of the components into their microteachings.

The findings of this study also indicated that teaching experience, another essential source of PCK, plays a critical role in facilitation of more interplay among the PCK components. Therefore, it seems reasonable to suggest effective teaching experiences for preservice teachers in order to catalyze a dynamic relationship among PCK components as well as PCK development. Additionally, this study implies that teacher efficacy mediates teacher actions. Teacher efficacy appears to play a significant role in teachers' use of PCK components and construction of interactions among them, as well as teaching effectiveness. Therefore, teacher education programs should place more emphasis on teacher beliefs. Considering the relation between teacher efficacy and teaching experience, teacher education programs should provide preservice teachers with an extensive practicum experience in cooperating schools so that they gain successful mastery experiences to increase their teacher efficacy, which in turn to develop their PCK. For instance, practice teaching courses may be revised to increase preservice teachers' teaching experiences in cooperating high schools.

Moreover, the findings of this study imply several implications for in-service teacher education programs. The findings showed that teaching experience plays an influential role in obtaining distinctive science teaching orientations. Still, the novice

and experienced teachers had strong didactic orientation. Moreover, this study implies that both novice and experienced teachers should be guided in translating their ideal orientations into their instructional practices. The findings also showed that both novice and experienced teachers need support for implementing subject-specific instructional strategies, which is consistent with their ideal orientations. Therefore, teacher educators need to pay attention to the science teaching orientations held by in-service teachers, which may affect their use of subject-specific instructional strategies. In professional development programs, teachers should be dissatisfied with their simplistic views of teaching, and provided opportunities to make their teachings much more student-centered and reform-based. Teacher educators should guide and provide mentoring them to transfer their ideal orientations into their real practices. For instance, during professional development activities, teachers may design an instruction by utilizing a subject-specific instructional strategy (e.g., inquiry, learning cycle), which is more student-centered and reform-based. In this way, they can find an opportunity to translate their ideal orientations (e.g., discovery and inquiry) into their instructional practices as well as integrate their orientations with their subject-specific instructional strategies.

Moreover, this study implies that in-service teachers, especially novice teachers, need support for the use of PCK components simultaneously in their own classrooms. Novice teachers need support to translate the integration of PCK components from knowledge into their teaching practice. Mentoring program that MoNE provides to novice teachers by assigning an experienced teacher to each of them to enhance their instruction should explicitly focus on both PCK components and integrations of them. To the observation forms that experienced teachers use during this program, all PCK components should be added in an integrative way and novice teachers should be evaluated in terms of the integration of the PCK components. For an effective teaching, novice teachers should be supported in order to integrate PCK components and enact them within a context by the help of professional development activities. These activities should focus on making PCK much more explicit in different science topics in order to enable them to notice the

process of the interactions of the components. For instance, in-service teachers may be introduced with CoRe as a lesson planning tool which helps teachers develop their topic-specific PCK and integration of the components. They may prepare CoRes for different topics in groups. After preparing the CoRes, groups may make reflections on the CoRes by focusing on PCK components and the integrations among them. Then, they may implement these CoRes in their actual classrooms and take video-records of their own instructions. After that, during professional development programs, by watching these videos, they may make reflections on their performance focusing on how they apply their CoRes, how they translate the integration of PCK components from knowledge into their teaching practice. These critical and detailed analyses of their performance provide teachers to see their own strong and weak parts of their performance. Then, they may initiate a discussion on how they develop their teaching as well as the integration of PCK components. As a conclusion, teaching performance and specific performance feedback from a colleague/expert may provide them mastery experiences and verbal persuasion, which enhance their teacher efficacy. Particularly for novice teachers, in addition to mastery experiences, verbal persuasion in the form of encouragement and advice is a powerful source of efficacy (Mulholland & Wallace, 2001). Moreover, during professional development activities, sample cases may be analyzed. These cases may draw a profile of how experienced teachers integrate their PCK components into their teachings. After watching experienced teachers' teaching, they can discuss the use of their PCK and the integration of the components. Experienced teachers' rich repertoire of teaching specific topics and how they connect PCK components during instructions serve as a guide/model for novice teachers in order to develop their own teaching. This may provide vicarious experiences, one of the sources of efficacy, for the in-service teachers (Bandura, 1977). When in-service teachers observe a credible model teaches well, the efficacy of the observer teachers may be improved.

Finally, the findings of this study imply several implications for policy makers. For example, in Turkey, MoNE identified teacher qualifications in 2011. For chemistry teaching, these qualifications consist of subject matter knowledge and

PCK. While identifying these qualifications, PCK components have been presented, but mostly in a linear/fragmented way. Instead, considering the findings of the present study, it can be suggested that the integrations of PCK components should be pointed out much more in these qualifications. Moreover, teacher education programs should inform preservice teachers about these qualifications. Professional development programs should notify in-service teachers about these qualifications. Therefore, MoNE should encourage teacher educators to organize professional development programs in order to help teachers obtain these qualifications. In-service teachers should be supported to attend to these programs as well. Moreover, in-service teachers should be evaluated in terms of these qualifications at regular intervals and necessary feedback should be given to them by teacher educators.

#### **5.4. Suggestions for Science Education Research**

This study has also several suggestions for science education research, which will contribute to a research on PCK, the interactions among PCK components and PCK development:

This study is an endeavour to understand the complex nature of integration among PCK components and sub-components in teaching reaction rate and chemical equilibrium. However, still it is necessary to understand how the PCK components and sub-components interact, and how their interactions influence the teachers' teaching in different topics within the same discipline. Further studies, therefore, should investigate the complex nature and dynamics of interactions among PCK components and sub-components as well as the effects of interactions in different topics within the same discipline on teaching practice.

In addition, this study helps making explicit what novice and experienced chemistry teachers actually do -how they utilize their PCK and connect PCK components to each other- when teaching reaction rate and chemical equilibrium. In further studies, researchers may employ longitudinal studies to examine whether the interactions among teachers' PCK components grow and improve significantly over time for different topics within the same discipline. By studying with both novice

and experienced teachers, researchers may examine and compare how these teachers construct their topic-specific PCK and the relationships between the components for teaching different topics. Moreover, future studies may focus on novice teachers in particular, which may help us specify the components that the novice teachers have difficulty in while integrating other components for different topics within the same discipline.

The present study displays an effort to understand the complex nature of the interaction between science teaching orientations and the other components. Still, there have been few empirical studies particularly investigating science teaching orientations of secondary science teachers (Friedrichsen & Dana, 2005). In addition, Friedrichsen et al. (2011) underlined that because of its complex nature, most published papers are not clear about the interactions of science teaching orientations with the other components, or simply omit most of the components. Therefore, more research should be conducted to investigate the interactions between science teaching orientations and other PCK components with all the sub-components in different topics within the same discipline. Still, more empirical studies are needed to understand the role of teaching experience in science teaching orientations.

Furthermore, utilizing PCK map approach helps me designate the components that teachers have difficulty in while integrating other components for different topics within the same discipline. In addition, this method helped me comprehend how PCK components are structured for teaching reaction rate and chemical equilibrium. In this regard, in further studies, this approach can be used to examine how PCK components are structured for teaching different topics in chemistry. Moreover, with further research efforts, PCK map approach can be used to investigate how PCK relates to student outcomes, which is an unanswered question in PCK literature. In addition, PCK map approach should be developed to be able investigate the strength and quality of the interactions among PCK components across different topics. Therefore, further studies which examine the strength and quality of the interactions will produce useful implications for practice.



## REFERENCES

- Abell, S.K. (2007). Research on science teacher knowledge. In S.K. Abell & N. G. Lederman (Ed.), *Handbook of Research on Science Education* (pp. 1105-1149). Mahwah, Nj:Lawrence.
- Abell, S. K. (2008). Twenty years later: Does pedagogical content knowledge remain a useful idea? *International Journal of Science Education*, 30(10), 1405-1416.
- Arzi, H., & White, R. (2007). Change in teachers' knowledge of subject matter: A 17-year longitudinal study. *Science Education* 92(2), 221–251.
- Aydin, S. (2012). *Examination of chemistry teachers' topic-specific nature of pedagogical content knowledge in electrochemistry and radioactivity*. Unpublished Doctoral Dissertation. Middle East Technical University, Ankara, TURKEY.
- Aydin, S., Demirdogen, B., Akin, F. N., Uzuntiryaki-Kondakci, E., & Tarkin, A. (2015). The nature and development of interaction among components of pedagogical content knowledge in practicum. *Teaching and Teacher Education*, 46, 37-50.
- Aydin, S., & Boz, Y. (2013). The nature of integration among PCK components: A case study of two experienced chemistry teachers. *Chemistry Education: Research and Practice*, 14, 615-624.
- Aydin, S., Friedrichsen, P. M., Boz, Y., & Hanuscin, D. L. (2014). Examination of the topic- specific nature of pedagogical content knowledge in teaching electrochemical cells and nuclear reactions. *Chemistry Education: Research and Practice*, 15, 658-674.
- Bandura, A. (1977). *Self-efficacy: Toward a unifying theory of behavioral change*. *Psychological Review*, 84, 191–215.
- Baxter, J. A., & Lederman, N. G. (1999). Assessment and measurement of pedagogical content knowledge. In: J. Gess-Newsome & N. G. Lederman (Eds.), *Examining pedagogical content knowledge* pp.147-160). Dordrecht, Netherlands: Kluwer Academic Publishers.
- Brown, P., Abell, S., & Friedrichsen, P. (2008). *Investigating teacher knowledge of learners and learning and sequence of science instruction in an alternative certification program*. Paper presented at the National Association for Research in Science Teaching, Baltimore, MA.

- Brown, P., Friedrichsen, P., & Abell, S. (2013). The development of prospective secondary biology teachers PCK. *Journal of Science Teacher Education*, 24, 133–155.
- Bucat, R. (2005). Implications of chemistry education research for teaching practice: Pedagogical content knowledge as a way forward. *Chemical Education International*, 6(1), 1-2.
- Cakmakci, G. (2010). Identifying alternative conceptions of chemical kinetics among secondary school and undergraduate students in Turkey. *Journal of Chemical Education*, 87(4), 449-455.
- Chang, R., & Overby, J. (2011). *General chemistry: The essential concepts* (6<sup>th</sup> ed.). Mc Graw Hill.
- Clermont, C.P., Borko, H., & Krajcik, J.S. (1994). Comparative study of the pedagogical content knowledge of experienced and novice chemical demonstrators. *Journal of Research in Science Teaching*, 31, 419–441.
- Cochran, K.F., DeRuiter, J., & King, R. (1993). Pedagogical content knowing: An integrative model for teacher preparation. *Journal of Teacher Education*, 44(4), 263-272.
- Cochran, K. F., King, R. A., & De Ruiter, J. A. (1991). *Pedagogical content knowledge: A tentative model for teacher preparation*. Paper presented at the Annual Meeting of the American Educational Research Association, April, 1991, Chicago.
- Cohen, R., & Yarden, A. (2009). Experienced junior-high-school teachers' PCK in light of a curriculum change: The cell is to be studied longitudinally. *Research in Science Education*, 39, 131-155.
- Creswell, J. W. (2007). *Qualitative inquiry and research design: Choosing among five traditions*. London, UK: Sage
- Creswell, J. W. (2009). *Qualitative, quantitative, and mixed methods approaches*. Thousand Oaks, California: Sage Publications.
- Davis, E. A., & Krajcik, J. S. (2005). Designing educative curriculum materials to promote teacher learning. *Educational Researcher*, 34(3), 3-14.
- De Jong, O., & van Driel, J. H. (2004). Exploring the development of student teachers' PCK of the multiple meanings of chemistry topics. *International Journal of Science and Mathematics Education*, 2, 477-491.

- De Jong, O., van Driel, J., & Verloop, N. (2005). Preservice teachers' pedagogical content knowledge of using particle models in teaching chemistry. *Journal of Research in Science Teaching*, 42, 947-964.
- Demirdöğen, B. (2012). *Development of pre-service chemistry teachers' pedagogical content knowledge for nature of science: An intervention study*. Unpublished Doctoral Dissertation. Middle East Technical University, Ankara, TURKEY.
- Demirdöğen, B. (2016). Interaction between science teaching orientation and pedagogical content knowledge components. *Journal of Science Teacher Education*, 27(5), 495-532.
- Erduran, S., Bravo, A. A., & Naaman, R. M. (2007). Developing epistemologically empowered teachers: Examining the role of philosophy of chemistry in teacher education. *Science & Education*, 16, 975-989.
- Fernandez-Balboa, J. M., & Stiehl, J. (1995). The generic nature of pedagogical content knowledge among college professors. *Teaching and Teacher Education*, 11(3), 293-306.
- Friedrichsen, P. J., Abell, K. A., Pareja, E. M., Brown, P. L., Lankford, D. M., & Volkmann, M. J. (2009). Does teaching experience matter? Examining biology teachers' prior knowledge for teaching in an alternative certification program. *Journal of Research in Science Teaching*, 46(4), 357-383.
- Friedrichsen, P. M., & Dana, T. M. (2003). Using a card-sorting task to elicit and clarify science-teaching orientations. *Journal of Science Teacher Education*, 14(4), 291-309.
- Friedrichsen, P. M., & Dana, T. M. (2005). Substantive-level theory of highly regarded secondary biology teachers' science teaching orientations. *Journal of Research in Science Teaching*, 42(2), 218-244.
- Friedrichsen, P., van Driel, J. H., & Abell, S. K. (2011). Taking a closer look at science teaching orientations. *Science Education*, 95, 358-376.
- Gabel, D. (1999). Improving teaching and learning through chemistry education research: A look to the future. *Journal of Chemical education*, 76, (4), 548-554.
- Gess-Newsome, J. (1999). Pedagogical content knowledge: An introduction and orientation nature, sources and development of pedagogical content knowledge for science teaching, In J. Gess-Newsome & N. G. Lederman (Eds.). *Examining pedagogical content knowledge* (pp.3-17). Dordrecht, Netherlands: Kluwer Academic Publishers.

- Gess-Newsome, J. (2015). A model of teacher professional knowledge and skill including PCK. In A. Berry, P. Friedrichsen & J. Loughran (Eds.). *Re-examining Pedagogical Content Knowledge in Science Education*. (pp.28-42) . Routledge.
- Gibbs, G. R. (2007). *Analyzing qualitative data*. In U. Flick (Ed.). The Sage qualitative research kit. London: Sage.
- Glaser, B. G., & Strauss, A. L. (1967). *The discovery of grounded theory: Strategies for qualitative research*. Chicago, IL: Aldine Publishing Company.
- Grossman, P.L. (1990). *The making of a teacher: Teacher knowledge and teacher education*. New York: Teachers College Press.
- Haney, J. J., & McArthur, J. (2002). Four case studies of prospective science teachers' beliefs concerning constructivist teaching practices. *Science Education*, 86, 783-802.
- Hashweh, M. Z. (2005). Teacher pedagogical constructions: A reconfiguration of pedagogical content knowledge. *Teachers and Teaching: Theory and Practice*, 11, 273-292.
- Henze, I., Van Driel, J., & Verloop, N. (2008). Development of experienced science teachers' pedagogical content knowledge of models of the solar system and the universe. *International Journal of Science Education*, 30(10), 1321-1342.
- Kagan, D. M. (1990). Ways of evaluating teacher cognition: Inferences concerning the Goldilocks Principle. *Review of Educational Research*, 60(3), 419-469.
- Kamen, M. (1996). A teacher's implementation of authentic assessment in an elementary science classroom. *Journal of Research in Science Teaching*, 33(8), 859-877.
- Kaya, O. N. (2009). The nature of relationships among the components of pedagogical content knowledge of pre-service science teachers: 'Ozone layer depletion' as an example. *International Journal of Science Education*, 31(7), 961-988.
- Kind, V. (2009). Pedagogical content knowledge in science education: perspectives and potential for progress. *Studies in Science Education*, 45(2), 169-204.
- Knoblauch, D. & Woolfolk Hoy, A. (2008). "Maybe I can teach those kids." The influence of contextual factors on student teachers' efficacy beliefs. *Teaching and Teacher Education*, 24, 166-179.
- LeCompte M. D., & Preissle J. (Eds.). (1993). *Ethnography and qualitative design in educational research* (2nd ed.). San Diego, CA: Academic Press.

- Lee, E., Brown, M. N., Luft, J. A., & Roehrig, G. H. (2007). Assessing beginning secondary science teachers' PCK: Pilot year results. *School Science and Mathematics, 107*(2), 52-60.
- Lee, E., & Luft, J. A. (2008). Experienced secondary science teachers' representations of pedagogical content knowledge. *International Journal of Science Education, 30*(10), 1343-1363.
- Leite, L., Mendoza, J., & Borsese, A. (2005). Teachers' and prospective teachers' explanations of liquid-state phenomena: a comparative study involving three European countries. *Journal of Research in Science Teaching, 44*(2), 349-374.
- Lincoln, Y. S., & Guba, E. G. (1985). *Naturalistic inquiry*. Thousand Oaks, CA: Sage.
- Loughran, J., Milroy, P., Berry, A., Gunstone, R., & Mulhall, P. (2001). Documenting science teachers' pedagogical content knowledge through PaP-eRs. *Research in Science Education, 31*(2), 289-307.
- Loughran, J., Mulhall, P., & Berry, A. (2004). In search of pedagogical knowledge in science: Developing ways of articulating and documenting professional practice. *Journal of Research in Science Teaching, 41*, 370-391.
- Loughran, J., Berry, A., & Mulhall, P. (2006). *Understanding and developing science teachers' pedagogical content knowledge*. Rotterdam: Sense Publishers.
- Loughran, J., Mulhall, P., & Berry, A. (2008). Exploring pedagogical content knowledge in science teacher education. *International Journal of Science Education 30*(10), 1301-1320.
- Luft, J. A. (2009). Beginning secondary science teachers in different induction programs: The first year of teaching. *International Journal of Science Education, 31*(17), 2355-2384.
- Luft, J. A., Firestone, J. B., Wong, S. S., Ortega, I., Adams, K., & Bang, E. (2011). Beginning secondary science teacher induction: A two-year mixed methods study. *Journal of Research in Science Teaching, 48*(10), 1199-1224.
- Magnusson, S., Krajcik, J., & Borke, H. (1999). Nature, sources and development of pedagogical content knowledge for science teaching. In J. Gess-Newsome & N.G. Lederman (Eds.), *Examining pedagogical content knowledge: The construct and its implications for science education* (pp. 95-132). Dordrecht, Netherlands: Kluwer Academic Publishers.
- Merriam, S. B. (2009). *Qualitative research: A guide to design and implementation*. San Francisco: Jossey-Bass.

- Miles, M. B., & Huberman, A. M. (1994). *Qualitative data analysis: An expanded sourcebook* (2nd Ed.). Thousand Oaks: Sage Publications.
- Mohlouoa, N. H., Rollnick, M., & Oyoo, S. O. (2013). The Use of Content Representation as a Tool: Exploring the Pedagogical Content Knowledge of Two Lesotho Physics Teachers in the Process of Teaching Radioactivity. *The International Journal of Science, Mathematics and Technology Learning*, 19, 29-37.
- Ministry of National Education (2011). *Secondary 11<sup>th</sup> Grade Chemistry Curriculum*. Ankara, Turkey: Ministry of Education.
- Morine-Dershimer, G., & Kent, T. (1999). The complex nature and sources of teachers' pedagogical content knowledge. In J. Gess-Newsome & N. G. Lederman (Eds.), *Examining pedagogical content knowledge* (pp. 21–50). Dordrecht, Netherlands: Kluwer Academic Publishers.
- Mulholland, J., & Wallace, J. (2001). Teacher induction and elementary science teaching: enhancing self-efficacy. *Teaching and Teacher Education*, 17, 243–261.
- Nilsson, P. (2008). Teaching for understanding: The complex nature of pedagogical content knowledge in pre-service education. *International Journal of Science Education*, 30(10), 1281-1299.
- Nilsson, P., & Loughran, J. (2011). Exploring the development of pre-service science elementary teachers' pedagogical content knowledge. *Journal of Science Teacher Education*, 23(7), 699-721.
- Park, S., & Chen, Y. C. (2012). Mapping out the integration of the components of pedagogical content knowledge (PCK): Examples from high school biology classrooms. *Journal of Research in Science Teaching*, 49(7), 922-941.
- Park, S., & Oliver, J. S., (2008a). Revisiting the Conceptualization of Pedagogical Content Knowledge (PCK): PCK as a Conceptual Tool to Understand Teachers as Professionals. *Research in Science Education*, 38, 261-284.
- Park, S., & Oliver, J. S. (2008b). National Board Certification (NBC) as a catalyst for teachers' learning about teaching: The effects of the NBC process on candidate Teachers' PCK development. *Journal of Research in Science Teaching*, 45(7), 812–834.
- Padilla, K., & Van Driel, J. (2011). The relationships between PCK components: The case of quantum chemistry professors. *Chemistry Education Research and Practice*, 12(3), 367-378.
- Patton, M. Q. (2002). *Qualitative Research and evaluation methods* (3rd ed.). Thousand Oaks, California: Sage Publications, Inc.

- Sickel A., (2012). *Examining beginning biology teachers' knowledge, beliefs, and practice for teaching natural selection*. Unpublished Doctoral Dissertation. University of Missouri, Columbia, USA.
- Settlage, J. (2000). Understanding to learning cycle: Influences on abilities to embrace the approach by preservice elementary school teachers. *Science Education*, 84, 43-50.
- Shulman, L.S. (1986). Those who understand: Knowledge growth in teaching. *Educational Researcher*, 15(2), 4–14.
- Shulman, L.S. (1987). Knowledge and teaching: Foundations of the new reform. *Harvard Educational Review*, 57(1), 1–22.
- Tamir, P. (1988). Subject matter and related pedagogical knowledge in teacher education. *Teaching and Teacher Education*, 4(2), 99-110.
- Tyson, L., Treagust, D. F., & Bucat, R. B. (1999). The complexity of teaching and learning chemical equilibrium. *Journal of Chemical Education*, 76(4), 554–558.
- Van Driel, J., Verloop, N., & de Vos, W. (1998). Developing science teachers' pedagogical content knowledge. *Journal of Research in Science Teaching*, 35, 673–695.
- Van Driel, J., Beijaard, D., & Verloop, N. (2001). Professional development and reform in science education: The role of teachers' practical knowledge. *Journal of Research in Science Teaching*, 38(2), 137-158.
- Van Driel, J., De Jong, O., & Verloop, N. (2002). The development of preservice chemistry teachers' pedagogical content knowledge. *Science Education*, 86, 572–590.
- Veal, W. R., & Kubasko, W. R. (2003). Biology and geology teachers' domain-specific pedagogical content knowledge of evolution. *Journal of Curriculum and Supervision*, 18(4), 344–352.
- Veal, W. R., & MaKinster, J. G. (1999). Pedagogical content knowledge taxonomies. *Electronic Journal of Science Education*, 3(4).
- Voska, K. W., & Heikkinen, H. W. (2000). Identification and analysis of student conceptions used to solve chemical equilibrium problems. *Journal of Research in Science Teaching*, 37(2), 160-176.
- Wilson, S. M., Shulman, L. S., & Richert, E. R. (1987). '150 different ways' of knowing: Representations of knowledge in teaching. In: J. Calderhead (Eds.), *Exploring teachers' thinking* (pp. 104–124). New York: Taylor and Francis.

Yin, R. K. (2009). *Case study research: Design and methods* (4<sup>th</sup> ed.). Thousand Oaks, California: Sage Publications.



## APPENDIX A

### CARD-SORTING ACTIVITY (IN TURKISH)

#### KART GRUPLAMA AKTİVİTESİ

Bir kimya öğretmeni olarak,

1. Öğrencilere anlık ve ortalama reaksiyon hız değerlerinin ayrımını öğretmenin en etkili yolu, düz anlatım yöntemiyle tahtaya anlık ve ortalama reaksiyon hızı formüllerini yazıp ikisi arasındaki farkı anlatmaktır. (Didactic)
2. Kimyasal denge konusunu öğretmenin en iyi yolu, öğrencilere laboratuvar aktiviteleri yaptırmaktır. (Activity-driven)
3. Reaksiyon hızının zamanla nasıl değiştiğini öğretmenin en etkili yolu, öğrencilerin hız-zaman ilişkisini keşfedebilecekleri bir etkinlik planlamaktır. (Discovery)
4. Reaksiyon ısısı ve aktivasyon enerjisi arasındaki ilişkiyi öğretmenin en iyi yolu, sorular sorarak yanlış kavramaları belirlemek ve sonrasında sahip oldukları yanlış kavramaları gidermeye çalışmaktır (Conceptual change)
5. Le Chatelier İlkesini öğretmenin en iyi yolu, konu ile ilgili farklı ve zor sorular çözmektir. (Academic-rigor)
6. Reaksiyon hızının bağlı olduğu etkenleri öğretmenin en iyi yolu, öğrencilerin değişkenlerine kendilerinin karar verdikleri bir deney tasarımlarına, uygulamalarına ve elde ettikleri sonuçları yorumlamalarına olanak sağlamaktır. (Guided inquiry)
7. Endotermik ve ekzotermik tepkimelerde denge sabitinin sıcaklıkla olan ilişkisini öğretmenin en etkili yolu, farklı reaksiyonlar için hesaplanan  $K_c$  değerlerinin sıcaklıkla değişimini içeren veriler kullanmaktır. Daha sonra öğrencilerden “neden bazı reaksiyonlarda  $K_c$  değeri sıcaklıkla artarken bazı reaksiyonlarda  $K_c$  değeri

azalır” ile ilgili hipotez kurmalarını, verileri yorumlamalarını, analiz etmelerini ve sonuçlarını sınıftaki diğer öğrencilerle paylaşmalarını istemektir. (process)

**8.** Reaksiyon hızları ve kimyasal denge ünitesini öğretmenin en iyi yolu, öğrencilerin günlük hayatta bu ünite ile ilgili olarak karşılaştıkları gerçek bir problemin çözümü üzerine bir proje yapmalarını sağlamaktır. (Project-based science)

**9.** Reaksiyon hızları ve kimyasal denge ünitesindeki kavramların tarihsel gelişimi hakkında bilgi vererek konuya başlamak, bu konuyu anlatmanın en etkili yoludur. (Curriculum goal: History of science)

**10.** Öğrencilere, içinde reaksiyon hızı ve kimyasal denge kavramlarının anlamlı bir şekilde kullanıldığı grup oyunları oynatmak, bu konuları öğretmenin en iyi yoludur. (Curriculum goal: Terminology)

**11.** Öğrencileriniz için yapabileceğiniz en iyi şeyin onları üniversiteye hazırlamak olduğunu düşünür ve bu nedenle, konuyu öğrettikten sonra soru çözmeye çalışırsınız. (High stakes university entrance exam)

**12.** Bu konuyu öğretmenin en iyi yolu, konuyu anlatırken teknoloji vurgusu yapmak ve teknoloji ile toplum ilişkisini öne çıkarmaktır. (Curriculum goal: STS)

## APPENDIX B

### CONTENT REPRESENTATION (CoRe)

IMPORTANT SCIENCE IDEAS/CONCEPTS			
What you intend the students to learn about this idea	Big Idea 1	Big Idea 2	Etc.
Why it is important for students to know this			
What else you know about this idea (that you do not intend students to know yet)			
Difficulties/limitations connected with teaching this idea			
Knowledge about students' thinking which influences your teaching of this idea			
Other factors that influence your teaching of this idea			
Teaching procedures (and particular reasons for using these to engage with this idea)			
Specific ways of ascertaining students' understanding or confusion around this idea(include likely range of responses)			



## APPENDIX C

### SAMPLE INTERVIEW QUESTIONS

#### Örnek Görüşme Soruları

##### Fen ve Kimya Öğretiminin Amaçları

1. Sizce lisede neden fen/kimya öğretiyoruz? Sizin kimya öğretmedeki amaçlarınız nelerdir?
2. Bahsettiğiniz bu amaçları/hedefleri nasıl belirlediniz?
3. Fen öğretiminde öğretmenin ve öğrencinin rolü nedir?

##### Konuyu Bilmenin Önemi

1. Öğrencilerin reaksiyon hızı/kimyasal denge konusunu bilmesi neden önemlidir?
2. Öğrencilerin reaksiyon hızı/kimyasal denge konusunu öğrenmeleri onlara ne gibi avantajlar sağlar? Neden?

##### Öğretim Programı Bilgisi

1. Sizce öğrencilerin reaksiyon hızı/kimyasal denge konusunda öğrenmesi gereken en önemli kavramlar/noktalar nelerdir? Bu kavramları/noktaları nasıl belirlediniz?
2. Öğretim programında reaksiyon hızı/kimyasal denge konusuna temel oluşturan konular nelerdir?
3. Öğretim programını kullanmada ne kadar iyisiniz? Neden iyi/kötü olduğunuzu düşünüyorsunuz? Ya da bu kaniya nasıl vardınız?

##### Öğrenci Bilgisi

1. Öğrenciler reaksiyon hızı/kimyasal denge konusunu öğrenebilmeleri için hangi ön bilgi ve becerilere sahip olmalıdırlar? Neden?
2. Öğrenciler bu bilgileri nereden öğrenmiş olabilir?

3. Reaksiyon hızı/kimyasal denge konusunda öğrencilerin zorlandıkları noktaları/yanlış kavramaları ortaya çıkarmada kendinizi ne kadar yeterli hissediyorsunuz?

### **Öğretim Stratejileri Bilgisi**

1. Öğrencilerinizin reaksiyon hızı/kimyasal denge konusundaki kavramları anlamasına yardımcı olmak için hangi öğretim stratejilerini kullanacaksınız?
2. Reaksiyon hızı/kimyasal denge konusunu öğretirken öğrencilerinizin yanlış kavramalara sahip olduklarının farkına varsanız ne yaparsanız?
3. Öğrencilerin kafası karıştığında ne kadar alternatif açıklama ya da örnek sağlayabilirsiniz?

### **Değerlendirme Bilgisi**

1. Öğrencilerin reaksiyon hızı/kimyasal denge konusunda ne öğrendiklerini hangi ölçme tekniklerini kullanarak ölçersiniz?
2. Bu ölçme tekniklerini kullanmayı tercih etmenizin sebepleri nelerdir?
3. Öğretiminizi değerlendirme yolları bulmada ne kadar iyisiniz? Neden iyi/kötü olduğunuzu düşünüyorsunuz? Ya da bu kanıya nasıl vardınız?

## APPENDIX D

### PCK CODING TABLE

PCK coding table used in this Study (Roberts, 1988; Magnusson et al., 1999, MoNE, 2011)

Codes	Sub-codes	Definition
Science teaching orientations	Didactic	Transfer the facts of science
	Activity-driven	Make learners active with materials and hands-on experiences
	Discovery	Supply opportunities for learners to discover aimed science concepts on their own
	Conceptual change	Ease the improvement of scientific knowledge by contradicting learners with contexts to clarify that challenge their naive conceptions
	Academic-rigor	Present a specific body of knowledge
	Guided-inquiry	Found a community of students whose members share responsibility for comprehension the physical world, especially with respect to utilizing the tools of science
	Project-based science	Include learners in examining solutions to authentic problems
	Process	Help learners improve science process skills
	History of science	Develop an understanding of the historical improvement of basic concepts of the matter
	Science-technology-society	Develop an understanding of the effects of concepts on individuals, social, economic and technological world
	Terminology	Develop skills for utilizing chemical terminology for explaining those concepts or models
	High Stakes University Entrance Exam	Prepare learners for high stakes university entrance exam
	Everyday coping	Use science to understand everyday objects and events
Knowledge of curriculum	Knowledge of goals and objectives	Teachers' knowledge of goals and objectives related to their subjects for students
	Knowledge of horizontal curriculum	Teachers' knowledge of curriculum about relations to other topics in the same grade in their subjects
	Knowledge of vertical curriculum	Teachers' knowledge of curriculum about vertical relations of the topic to the earlier and later grades

PCK coding table used in this Study (Roberts, 1988; Magnusson et al., 1999, MoNE, 2011) (continued)

Knowledge of learner	Knowledge of requirements for learning Knowledge of areas of student difficulty Knowledge of areas of student misconception	Teachers' knowledge about prerequisite knowledge needed for learners in order to learn particular scientific topics Teachers' knowledge about science concepts or topics that learners find difficult to learn. Teachers' knowledge about learners' ideas different from scientifically accepted description
Knowledge of assessment	Knowledge of dimensions of science learning to assess (What to assess) Knowledge of methods of assessment (How to assess)	Teachers' knowledge about assessment of students' learning as related to stated goals Teachers' knowledge of how to assess student learning as related to stated goals
Knowledge of instructional strategies	Knowledge of subject-specific strategies for science teaching Knowledge of topic-specific strategies for science teaching	Teachers' knowledge of strategies used for teaching science which are more general and particular to only teaching science (e.g., learning cycle, inquiry) Teachers' knowledge of topic-specific representations (e.g., analogies, models, examples) and topic-specific activities (e.g., experiments, demonstrations, simulations) for teaching specific topics in science

## APPENDIX E

### INSTUTIONAL REVIEW BOARD PERMISSION



DUMLUPINAR BULVARI 06800  
ÇANKAYA ANKARA/TURKEY  
T: +90 312 210 22 91  
F: +90 312 210 79 59  
oam@metu.edu.tr  
www.oam.metu.edu.tr

Sayı: 28620816/275-227

07.10 2013

Gönderilen : Doç. Dr. Esen Uzuntiryaki Kondakçı  
Fen ve Matematik Alanları Eğitimi Bölümü

Gönderen : Prof. Dr. Canan Özgen  
IAK Başkanı

İlgi : Etik Onayı

Danışmanlığını yapmış olduğunuz Fen ve Matematik Alanları Eğitimi Bölümü Doktora öğrencisi Fatma Nur Akın'ın "Deneyimli ve deneyimsiz kimya öğretmenlerinin Pedagojik Alan Bilgilerinin (PAB) ve PAB'in bileşenleri arasındaki ilişkinin "Reaksiyon Hızları ve Kimyasal Denge" Ünitesinde Karşılaştırılması" isimli araştırması "İnsan Araştırmaları Komitesi" tarafından uygun görülerek gerekli onay verilmiştir.

Bilgilerinize saygılarımla sunarım.

Etik Komite Onayı

Uygundur

07/10/2013

Prof. Dr. Canan Özgen  
Uygulamalı Etik Araştırma Merkezi  
(UEAM) Başkanı  
ODTÜ 06531 ANKARA



## CURRICULUM VITAE

**Fatma Nur AKIN**

### PERSONAL INFORMATION

**Date & Place of Birth** : 28.11.1984 - İZMİT  
**Marital Status** : Married, 1 child  
**Campus Address** : Middle East Technical University, Faculty of Education, Department of Mathematics and Science Education, 06800 Çankaya / ANKARA  
**Phone Number** : 0 505 651 2641  
**E-mail** : fatmanur@metu.edu.tr

### EDUCATION

- 2010 Fall – 2016 Fall (Expected): PhD Program in Mathematics and Science Education, Middle East Technical University, TURKEY (3,86/4,00 GPA)  
(Title of Thesis: The Nature of Interplay among Components of Pedagogical Content Knowledge in Reaction Rate and Chemical Equilibrium Topics of Novice and Experienced Chemistry Teachers)
- 2009: Master Degree (without thesis) of Secondary Science and Mathematics Education, Chemistry Education, Middle East Technical University, TURKEY
- 2004 – 2009: Bachelor of Secondary Science and Mathematics Education, Chemistry Education, Major, Middle East Technical University, TURKEY  
(High Honor Roll: 3,56/4,00 GPA)
- 2005 – 2009: Bachelor of Chemical Reaction Engineering, Minor, Middle East Technical University, TURKEY (2,93/4,00 GPA)
- 1999 – 2003: Bursa Milli Piyango Anatolian High School, TURKEY  
(4,88/5,00)

## **PROFESSIONAL EXPERIENCE**

- 2009- 2017, Research Assistant, Department of Mathematics and Science Education, Middle East Technical University

### Courses Participated in as a Teaching Assistant

#### Undergraduate Courses

- ✓ SSME 400- Computer Applications in Science Education (METU, Turkey)
- ✓ SSME 518- Instructional Technology and Material Development (METU, Turkey)
- ✓ CHEM 107- General Chemistry Laboratory (METU, Turkey)
- ✓ SSME 544- Practice Teaching in Science/Mathematics Education (METU, Turkey)
- ✓ SSME 512- Methods of Science/Mathematics Teaching (METU, Turkey)
- ✓ SSME 403- Laboratory Experiments in Science Education (METU, Turkey)
- ✓ SSME 534- School Experience in Science/Mathematics Education (METU, Turkey)

#### Graduate Courses

- ✓ SSME 520- Research Methods in Education (METU, Turkey)
- ✓ SSME 621- Critiques and Analyses of Research in Science and Math Education
- 2011, Educator, Seminar on Teacher Education
- 2009, Student assistant, Science and Society Museum, Middle East Technical University

## **AREA OF INTEREST**

- Chemistry Education
- Teacher Education
- Pedagogical Content Knowledge

- Self-efficacy Beliefs
- Self-Regulation
- Research Methods

## **PAPERS PUBLISHED IN JOURNALS**

- Uzuntiryaki, E., Demirdöğen, B., Akin, F. N., Tarkin, A., & Aydin, S. (2017). Exploring the complexity of teaching: The interaction between teacher self-regulation and pedagogical content knowledge. *Chemistry Education Research and Practice*, 18, 250-270. doi:10.1039/C6RP00223D (SSCI)
- Aydin, S., Demirdöğen, B., Akin, F. N., Uzuntiryaki, E., & Tarkin, A., (2015). The nature and development of interaction among components of pedagogical content knowledge in practicum. *Teaching and Teacher Education*, 46, 37-50. doi: 10.1016/j.tate.2014.10.008 (SSCI)
- Aydin, S., Demirdöğen, B., Tarkin, A., Kutucu, E. S., Ekiz, B., Akin, F. N., Tuysuz, M., & Uzuntiryaki, E. (2013). Providing meaningful experience to pre-service teachers: Mentoring enriched PCK based practicum course. *Science Education*, 97(6), 903-935. doi: 10.1002/sci.21080 (SSCI)
- Elmas, R., Akin, F. N., & Geban, Ö. (2013). Ask a scientist website; trends in chemistry questions in Turkey. *The Asia-Pacific Education Researcher*, 22(4), 559-569. doi: 10.1007/s40299-013-0058-0 (SSCI)

## **PAPERS PRESENTED IN CONFERENCES**

- Exploring Preservice Teachers' Use of Self-Regulatory Processes in their Instructions. Esen UZUNTİRYAKİ-KONDAKÇI, Betül DEMIRDÖĞEN Fatma Nur AKIN, Ayşegül TARKIN & Sevgi AYDIN. Paper presented in the EARLI SIG 11, June 2016, Zurich.
- In search of Interplay among PCK Components: The Case of Novice and Experienced Chemistry Teachers. Fatma Nur AKIN & Esen UZUNTİRYAKİ-KONDAKÇI. Paper presented in the ECER, September 2015, Budapest, HUNGARY.

- The Relationship between Pre-service Teacher Self-Regulation and PCK. Ayşegül TARKIN, Esen UZUNTİRYAKİ-KONDAKÇI, Fatma Nur AKIN, Betül DEMIRDÖĞEN, & Sevgi AYDIN. Paper presented at the meeting of NARST Annual International Conference, April 2015, Chicago, Illinois, USA.
- Nature and Development of Interplay among Pre-service Teachers' PCK Components in Mentoring Enriched PCK Based Practicum. Betül DEMIRDÖĞEN, Sevgi AYDIN, Fatma Nur AKIN, & Esen UZUNTİRYAKİ-KONDAKÇI. Paper presented at the meeting of NARST Annual International Conference, April, 2014, Pittsburgh, PA, USA.
- Novice and Experienced Chemistry Teachers' Pedagogical Content Knowledge Regarding Solutions Topic: The Role of Teaching Experience and Teacher Efficacy. Fatma Nur AKIN & Esen UZUNTİRYAKI. Paper presented in the ECER, September 2013, İstanbul, TURKEY.
- Providing Meaningful Experience to Pre-Service Teachers: Mentoring Enriched PCK Based Practicum Course. Ayşegül TARKIN, Betül DEMIRDÖĞEN, Sevgi AYDIN, Betül EKİZ, Elif Selcan KUTUCU, Fatma Nur AKIN, Mustafa TUYSUZ, & Esen UZUNTİRYAKI. Paper presented at the meeting of NARST Annual International Conference, April 2013, Puerto Rico, PR, USA.
- An Examination on Pre-service Teachers Self-Regulation Beliefs According to Gender. Esen UZUNTİRYAKI-KONDAKCI, Fatma Nur AKIN, Yeşim CAPA-AYDIN. Paper presented in the 10<sup>th</sup> National Science and Mathematics Education Conference, June 2012, Niğde, TURKEY.
- Needs Assessment for Teaching Assistants: What do They Need to Develop Teaching Skills? Sevgi AYDIN, Fatma Nur AKIN, Ayşegül TARKIN. Paper presented at World Conference on New Trends in Science Education, September 2011, Kuşadası, TURKEY.
- The Relation between Teacher Self Efficacy and Teacher Self-Regulation Beliefs: Canonical Correlation Analysis. Fatma Nur AKIN, Esen

UZUNTIRYAKI-KONDAKCI, Yeşim CAPA-AYDIN. Paper presented in the 2<sup>nd</sup> National Chemistry Education Conference, July 2011, Erzurum, TURKEY.

- Which Types of Knowledge that Chemistry Educators should have? Fatma Nur AKIN, Ayşegül TARKIN, and Sevgi AYDIN. Poster presented in the 2<sup>nd</sup> National Chemistry Education Conference, July 2011, Erzurum, TURKEY.

### **ADDITIONAL INFORMATION**

- TUBITAK-BIDEB-2211 PhD Scholarship (2009-2015)
- TUBITAK Article Awards (2013/2015)
- Middle East Technical University Article Awards (2013/2015/2016)
- Qualified for PhD Qualification Exam (2012)
- First Rank Student Award of Graduation from Department of Chemistry Education (2009)

### **PROJECTS**

- The Nature of *Pedagogical Content Knowledge of Preservice Teachers*, Bülent Ecevit University Research Fund, BAP-2014-76962555-01, Researcher, 2016.
- *Pedagogical Content Knowledge of Novice and Experienced Teachers: The Role of Teaching Experience and Teachers' Self-Efficacy Beliefs*, Middle East Technical University Research Fund, Researcher, 2013.
- *The Variables Predicting Teachers' Self-Regulation*, Middle East Technical University Research Fund, BAP-05-01-2011-002, Researcher, 2011.

### **COMPUTER SKILLS**

- Windows, MS Office, Internet tools
- SPSS

### **MEMBERSHIPS**

- National Association for Research in Science Teaching (NARST)