

INVESTIGATION OF NONLINEAR INTERACTIONS CAUSING THE MAJOR  
COAL MINE ACCIDENTS IN TÜRKİYE USING SYSTEM DYNAMICS  
MODELING

A THESIS SUBMITTED TO  
THE GRADUATE SCHOOL OF NATURAL AND APPLIED SCIENCES  
OF  
MIDDLE EAST TECHNICAL UNIVERSITY



BY  
CUMHUR KUTAY ERBAYAT

IN PARTIAL FULFILLMENT OF THE REQUIREMENTS  
FOR  
THE DEGREE OF MASTER OF SCIENCE  
IN  
MINING ENGINEERING

APRIL 2024



Approval of the thesis:

**INVESTIGATION OF NONLINEAR INTERACTIONS CAUSING THE  
MAJOR COAL MINE ACCIDENTS IN TÜRKİYE USING SYSTEM  
DYNAMICS MODELING**

submitted by **CUMHUR KUTAY ERBAYAT** in partial fulfillment of the requirements for the degree of **Master of Science in Mining Engineering, Middle East Technical University** by,

Prof. Dr. N. Emre Altun  
Dean, Graduate School of **Natural and Applied Sciences** \_\_\_\_\_

Prof. Dr. N. Emre Altun  
Head of the Department, **Mining Engineering** \_\_\_\_\_

Assoc. Prof. Dr. Onur Gölbaşı  
Supervisor, **Mining Engineering, METU** \_\_\_\_\_

**Examining Committee Members:**

Prof. Dr. Nuray Demirel  
Mining Engineering, METU \_\_\_\_\_

Assoc. Prof. Dr. Onur Gölbaşı  
Mining Engineering, METU \_\_\_\_\_

Asst. Prof. Dr. Fırat Atalay  
Mining Engineering, Hacettepe University \_\_\_\_\_

Date: 24.04.2024

**I hereby declare that all information in this document has been obtained and presented in accordance with academic rules and ethical conduct. I also declare that, as required by these rules and conduct, I have fully cited and referenced all material and results that are not original to this work.**

Name Last Name : Cumhuriyet Erbayat

Signature :

## ABSTRACT

### INVESTIGATION OF NONLINEAR INTERACTIONS CAUSING THE MAJOR COAL MINE ACCIDENTS IN TÜRKİYE USING SYSTEM DYNAMICS MODELING

Erbayat, Cumhuriyet  
Master of Science, Mining Engineering  
Supervisor: Assoc. Prof. Dr. Onur Gölbaşı

April 2024, 124 pages

The persistent reoccurrence of major accidents in the Turkish coal mining sector is notable. Despite implementing various measures and policy adjustments to enhance safety following each major accident, the system accumulates the potential for catastrophic events over time, leading to new incidents. This study delves into the intricate dynamics leading to recurring major coal mine accidents in Türkiye, employing System Dynamics (SD) modeling techniques. The study utilizes stock-and-flow diagrams to elucidate the nonlinear relationships contributing to major Turkish coal mining industry accidents. The simulation model integrates information from literature, official reports, and expert opinions in developing dependencies between negatively and positively correlated factors and their effects on risk accumulations. The study tries to understand the nuanced intricacies of the Turkish coal mining system and incorporates them into the model equations. The model aims to uncover key leverage points within the system by addressing endogenous parameters to provide actionable insights for minimizing the recurrence of major accidents. The interdisciplinary nature of this research, combining engineering principles with social and organizational dynamics, contributes to a holistic understanding of the complex system under investigation. The study results point out

that the Turkish underground coal mines are becoming more susceptible to major accidents for recurring periods. The model simulation describes the systemic causes of this fluctuating effect. The findings on the leverage points may provide insights for policymakers, industry stakeholders, and safety professionals when developing strategies to enhance the safety and resilience of coal mining operations in Türkiye.

Keywords: Major Mining Accidents, System Dynamics, Underground Coal Mines, Complex Systems, Dynamic Complexity



## ÖZ

# TÜRKİYE'DEKİ BÜYÜK KÖMÜR MADENİ KAZALARINA NEDEN OLAN DOĞRUSAL OLMAYAN ETKİLEŞİMLERİN SİSTEM DİNAMIĞI MODELLEMESİYLE İNCELENMESİ

Erbayat, Cumhur Kutay  
Yüksek Lisans, Maden Mühendisliği  
Tez Yöneticisi: Doç. Dr. Onur Gölbaşı

Nisan 2024, 124 sayfa

Türkiye kömür madenciliği sektöründe yaşanan büyük kazaların belirli aralıklarla tekrar etmesi dikkat çekici bir olgudur. Her büyük kaza sonrasında güvenliği artırmak için çeşitli mevzuat değişiklikleri yapılmasına ve önlemler uygulanmasına rağmen, kazaların meydana geldiği sistemlerde zaman içinde büyük kaza potansiyeli birikmekte ve bu durum yeni olayların meydana gelmesine yol açmaktadır. Bu çalışma, Sistem Dinamiği (SD) modelleme tekniklerini kullanarak Türkiye'de tekrarlayan kömür madeni felaketlerine yol açan karmaşık dinamikleri incelemektedir. Çalışma, Türkiye kömür madenciliği endüstrisindeki felaketlere katkıda bulunan doğrusal olmayan ilişkileri açıklamak için stok-akış diyagramlarından yararlanmaktadır. Simülasyon modeli, literatür bilgilerini ve resmi raporları bir araya getirerek, aralarında pozitif ve negatif korelasyonlar barındıran faktörleri ve bu faktörlerin risk birikime etkisini değerlendirmiştir. Bu çalışma, özellikle Türkiye'deki kömür madenciliği sisteminin etmenlerini anlamaya çalışmış ve bunları model denklemlerini oluşturmakta kullanmıştır. Simülasyon modeli, faciaların tekrarını en aza indirmek için eyleme geçirilebilir bilgiler sağlamak amacıyla içsel parametreleri ele alarak sistem içindeki önemli kaldıraç noktalarını

ortaya ıkarmak amacı ile oluşturulmuştur. Mühendislik ilkelerini sosyal ve örgütsel dinamiklerle birleştiren bu araştırmanın disiplinlerarası doğası, incelenen karmaşık sistemin bütünsel bir şekilde anlaşılmasına katkıda bulunmaktadır. Çalışma sonuçları Türkiyedeki yeraltı kömür madenlerinin büyük kaza oluşumuna olan yatkınlığının tekrarlayan periyotlarla arttığına işaret etmektedir. Bu dalgalanma etkisinin sistemik nedenleri simülasyon modeli ile açıklanmıştır. Kaldıraç noktalarına ilişkin bulgular, kanun yapıcılara, sektör paydaşlarına ve iş güvenliği profesyonellerine Türkiye'deki kömür madenciliği operasyonlarının güvenliğini ve dayanıklılığını artırmaya yönelik stratejiler geliştirirken fikir verebilir.

Anahtar Kelimeler: Büyük Maden Kazaları, Sistem Dinamiği, Yeraltı Kömür Madenleri, Kompleks Sistemler, Dinamik Komplekslik



To All the Lives We Have Lost in Coal Mines

## ACKNOWLEDGMENTS

First of all, I would like to express my sincere thanks and appreciation to my supervisor Assoc. Prof. Dr. Onur Gölbaşı for his guidance and endless support. I am very thankful for his technical discussions, constructive suggestions and sincere trust he has had with me. This thesis would not have been accomplished without his patience and inspiring encouragement. I would also like to present my sincere gratitude to the examining committee members, Prof. Dr. Nuray Demirel and Asst. Prof. Dr. Fırat Atalay for their valuable comments and suggestions on my thesis study.

I wish to thank Prof. Dr. Türker Özkan, as his courses were the window to the most profound thoughts on safety science with a broad perspective. I would also like to thank Ahmet Şen and Rıdvan Mevsim, as their deep understanding of safety science gained me a lot through our debates.

I am indebted to my family, especially my sisters Ebru Erbayat and Gülfem Erbayat. Their efforts have been the most significant influence on my curiosity about any topic.

Finally, I am thankful to my wife, Beyza, and my son, Barış, as they make the world a better place for me.

## TABLE OF CONTENTS

ABSTRACT.....	v
ÖZ.....	vii
ACKNOWLEDGMENTS.....	x
TABLE OF CONTENTS.....	xi
LIST OF TABLES.....	xiv
LIST OF FIGURES.....	xv
CHAPTERS	
1 INTRODUCTION.....	1
1.1 Background.....	1
1.2 Problem Statement.....	2
1.3 Objectives and Scopes of the Study.....	3
1.4 Research Methodology.....	4
1.5 Significance and Expected Contributions of the Thesis Study.....	5
2 LITERATURE REVIEW.....	7
2.1 Introduction.....	7
2.2 Uncertainty Assessment Methods for Occupational Health and Safety Cases.....	7
2.2.1 Linear Approaches.....	8
2.2.2 Nonlinear Approaches.....	9
2.3 Application Fields of System Dynamics Modelling for Complex Systems. .....	22
2.3.1 Transportation.....	27

2.3.2	Healthcare.....	28
2.3.3	Management Science.....	29
2.3.4	Environmental Sciences.....	30
2.3.5	Human Factors and Safety Science.....	31
2.4	System Dynamics Applications for OHS-Related Aspects in Mining.....	34
2.5	Study Motivation.....	46
3	A BACKGROUND DISCUSSION ON THE CAUSES OF MAJOR COAL MINE ACCIDENTS.....	49
3.1	Introduction.....	49
3.2	Recursive Behaviors of Major Coal Mine Incidents.....	50
3.2.1	The General Problem Definition.....	50
3.2.2	Major Coal Mine Accidents as An Outcome of Dynamic Complexity. .....	52
3.3	Baseline System Dynamics Models for Coal Mine Accidents.....	53
3.3.1	The Safety Subsystem.....	54
3.3.2	The Production Subsystem.....	57
3.3.3	The Human Resources Subsystem.....	59
3.3.4	The Mine Capacity and Task Management Subsystems.....	62
3.4	The Complex Nature of the Turkish Coal Mining Industry.....	64
3.4.1	The Investigations on the Soma Mine Fire.....	64
3.4.2	The Investigations on the Amasra Coal Mine Explosion.....	68
4	DEVELOPMENT OF THE SYSTEM DYNAMICS MODEL FOR MAJOR COAL MINING ACCIDENTS IN TÜRKİYE.....	71
4.1.1	Crucial Aspects and Boundary of the Conceptual Model.....	71
4.1.2	Subsystems of the Stock and Flow Diagram Model.....	76

4.1.3	The Safety Subsystem.....	77
4.1.4	The Production Subsystem .....	88
4.1.5	The Human Resources Subsystem.....	93
4.1.6	The Mine Management Subsystem.....	100
4.2	Implementation of the Developed Model for a Hypothetical Mine .....	103
4.2.1	Input Dataset .....	103
4.2.2	Implementation Results .....	105
5	CONCLUSIONS AND RECOMMENDATIONS .....	113
5.1	Conclusions .....	113
5.2	Recommendations .....	114
	REFERENCES .....	117

## LIST OF TABLES

### TABLES

Table 2-1. An Example Model Boundary Chart (Sterman, 1983) .....	16
Table 3-1. Major Coal Mine Incidents in Türkiye During the Last Decades .....	51
Table 4-1 The Boundaries Chart for Turkish Major Coal Mine Incidents Model ..	75
Table 4-2. The Building Blocks of a Stock-and-Flow Model .....	77
Table 4-3 Diagram Parameters and Variables of the Safety Subsystem .....	79
Table 4-4 Diagram Parameters and Variables of the Production Subsystem.....	90
Table 4-5 Diagram Parameters and Variables of the Human Resources Subsystem .....	95
Table 4-6 Diagram Parameters and Variables of the Mine Management Subsystem .....	102
Table 4-7 A Hypothetical Dataset for the Model Implementation.....	104

## LIST OF FIGURES

### FIGURES

Figure 1-1 A Demonstration of the Cyclic Nature of Major Coal Mine Incidents ...	2
Figure 1-2 Research Methodology of the Thesis Study.....	4
Figure 2-1. The domino model by Heinrich (1931).....	8
Figure 2-2. The overview of the STPA method (Leveson and Thomas, 2018).....	11
Figure 2-3. The Overview of SD Modeling Process (Sterman, 2000).....	12
Figure 2-4. Three Basic Components of SD Models (Sterman, 2000).....	13
Figure 2-5. Subsystems of the Westray Coal Mine Explosion (Cooke, 2003).....	17
Figure 2-6. A Sample Stock and Flow Illustration .....	19
Figure 2-7. Interaction/Coupling Chart (Perrow, 1984) .....	23
Figure 2-8. Bibliographic Coupling Network Map Based on Journals Showing the Themes of System Dynamics Researches Torres (2019).....	25
Figure 2-9. Frequencies of Tests Conducted in SD (Zanker et al., 2021) .....	26
Figure 2-10. The Core Part of the Stock-Flow Diagram for the Patient Flow Model by Davahli et al. (2020) .....	28
Figure 2-11. Food System Resilience Concept (Turner et al., 2016) .....	31
Figure 2-12. The Causal Loop Diagram of the Overall Model for the ETTO Principle (Kontogiannis and Malakis, 2019) .....	33
Figure 2-13 Causal loops for Westray Coal Mine Explosion (a) and a Generic Mine (b) (Cooke, 2003; Boukas and Kontogiannis, 2019) .....	39
Figure 2-14 Hybrid Framework Process Simplified from Jiao et al. (2022) .....	41
Figure 2-15 The Standardized Structural Equation Model by Yang et al. (2022)..	42
Figure 2-16 A comparative Study by Selebalo et al. (2021).....	43
Figure 3-1 Legislation Amendments and Major Coal Mine Incidents Timeline (adapted by TMMOB, 2021) .....	51
Figure 3-2 Safety Subsystem in Cooke (2003) .....	56
Figure 3-3 Safety Subsystem in Boukas and Kontogiannis (2019) .....	57
Figure 3-4 The Production Subsystem in Cooke (2003) .....	58

Figure 3-5 The Production Subsystem in Boukas & Kontogiannis (2019).....	59
Figure 3-6 The Human Resources Subsystem in Cooke (2003) .....	61
Figure 3-7 The Human Resources Subsystem in Boukas and Kontogiannis (2019) .....	62
Figure 3-8 The Mine Capacity Subsystem in Cooke (2003).....	63
Figure 3-9 The Task Management Subsystem in Boukas and Kontogiannis (2019) .....	64
Figure 4-1 The Model Subsystems.....	76
Figure 4-2 Stock-and-Flow Diagram of the Safety Subsystem.....	78
Figure 4-3 Management Commitment to Safety (MCS) Stock-And-Flow Loop....	84
Figure 4-4 Personal Commitment to Safety (PCS) Diagram .....	86
Figure 4-5 Stock-and-Flow Diagram of The Production Subsystem .....	89
Figure 4-6 Coal Mine Production Flow.....	92
Figure 4-7 Financial section of the production subsystem.....	93
Figure 4-8 The Human Resources Subsystem.....	94
Figure 4-9 Hiring Processes Stock-and-Flow diagram .....	99
Figure 4-10 Employee Competency Model .....	100
Figure 4-11 The Mine Management Subsystem .....	101
Figure 4-12 Variation of the Major Incident Risk Index in Time .....	106
Figure 4-13 Variation of the Management Commitment to Safety in Time .....	107
Figure 4-14 Variation of the Personal Commitment to Safety in Time .....	108
Figure 4-15 Variation of the Employee Satisfaction in Time .....	108
Figure 4-16 Variation of the Number of Experienced Employees in Time .....	109
Figure 4-17 Variation of the Employee Competency in Time .....	109
Figure 4-18 Variation of the Run of Mined Coal Production Rate in Time.....	110
Figure 4-19 Variation of the Employee Productivity in Time .....	110
Figure 4-20 Variation of the Investment in Safe Technologies in Time.....	111

# CHAPTER 1

## INTRODUCTION

### 1.1 Background

Major catastrophic accidents in Turkish coal mines have remained an unsolved problem for many years. In the last decades, explosions, mine fires, inundations, and slope failures have taken the lives of more than 539 miners in the Turkish coal mining industry. The catastrophic events are recurrent despite the technological improvements, policy enhancements, and increasing public interest in this subject. After each catastrophic event, public inquiries are conducted, retrospective investigations are carried out, and non-technical issues such as production pressure contracting practices are debated.

In the conventional understanding of occupational safety, it is necessary to analyze the causes of incidents and offer solutions to the identified problems. Although this approach based on identifying root causes is helpful in determining the technical measures that need to be taken, it generally cannot offer a holistic solution.

The idea that there are root causes that create accidents and that accidents can be prevented if those root causes are eliminated has long been criticized by systems-thinking researchers. The conventional approach sees the accident-generating sequence of events in a linear form, whereas system thinkers suggest that the relationships rather consist of feedback loops.

As Le Coze (2015) cites, Rasmussen (1988) was among the first researchers to use the feedback loops between different actors of a socio-technical system in the context of safety science. With different emphasis, complexity and linearity problem was also discussed by Perrow (1984) when describing his normal accidents theory.

In the systemic approach, there is a distinction between organizational accidents and individual accidents. Organizational accidents stem from multiple dimensions and accumulate over time, while individual accidents, being more frequent and less severe, have more easily identifiable causes in comparison. (Goh, 2012a) Therefore, organizational accidents should be handled differently than individual ones.

Thus, the current study intends to develop a conceptual model to understand the recurrent nature of major coal mine incidents in the Turkish mining industry. The study focuses on organizational accidents such as firedamp explosions and mine fires that result in multiple fatalities.

## 1.2 Problem Statement

The recurrence of major incidents in the Turkish coal mining industry is an observable phenomenon. The cyclic nature of the Turkish coal mine safety system is shown in Figure 1-1.



Figure 1-1 A Demonstration of the Cyclic Nature of Major Coal Mine Incidents

Whenever there is an organizational incident with severe consequences, a series of steps are taken to make policy changes to produce safety enhancements. Even though these measures are taken, the system accumulates the major incident potential in time, and a new catastrophic incident occurs. In this vicious cycle, the conventional occupational safety and health approach that aims to specify the improvement points from the investigations has been insufficient.

In this study, the assertion is that the system's behavior is compatible with the phenomenon called *drift into failure*, and his drift is due to the dynamic complexity of the Turkish coal mine safety system. To prevent that drifting, the leverage points of this system should be identified and addressed.

### **1.3 Objectives and Scopes of the Study**

The main objective of this study is to develop a conceptual model to understand the dynamic complexity of the major Turkish coal mine incidents. The idea is to seek an explanation of the problem in the dynamic interactions of endogenous parameters inside the system.

For this purpose, system dynamics modeling was utilized to model the problem. System dynamics modeling, developed in the 1950s by Professor Jay Forrester at MIT, provides a framework for addressing dynamic complexity, where the cause and effect relationships are better understood in feedback loops.

The scope is to produce a generic model that tries to explain the Turkish coal mine industry's disaster-producing potential. Sub-objectives of this research study can be summarized as i) produce an easy-to-understand model of major coal mine incidents, ii) incorporate the non-technical aspects in an accident model, iii) reveal the leverage points in the system that policymakers should prioritize, and iv) execute the simulation model that fits the Turkish coal mining industry context.

## 1.4 Research Methodology

This research study used a system dynamics methodology to model and simulate the dynamic complexity of Turkish coal mine safety in the scope of organizational incidents with catastrophic consequences.

The research methodology carried out in this study is shown in Figure 1-2. The causal loops are mapped in the study using the data from past catastrophic events and previously formed models. A simulation model was created in Stella Architect v.3.6 by adapting predefined assemblies and additional relationships valid for the Turkish coal mining industry context. The simulation run for a hypothetical coal mine operating in Türkiye to identify the major incident potential and the behavior of whole system. The results are depicted, discussed and suggestions for policy changes are made.

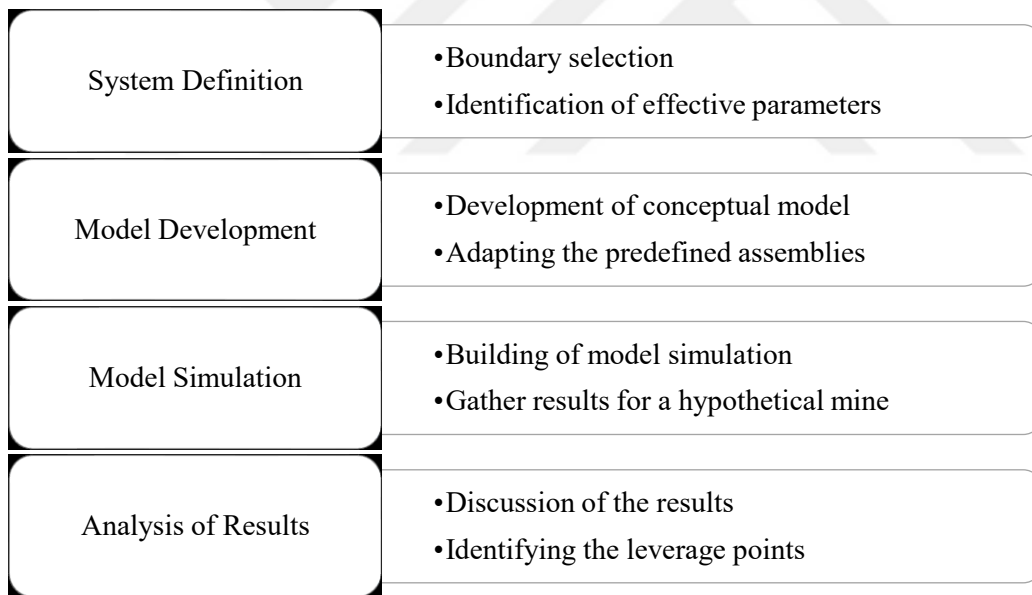

Figure 1-2 Research Methodology of the Thesis Study

## **1.5 Significance and Expected Contributions of the Thesis Study**

Despite various research studies that have been conducted to understand complex interactions in a safety context, the problem of the disastrous incident in the Turkish coal mining industry has never been modeled by system dynamics.

System dynamics applications for safety cases have been more common as systems thinking is more pronounced in safety science. It might be used to produce generic models and understand a case scenario. In this study, a generic model was formed and simulated. The study's uniqueness is the application of system dynamics modeling to the Turkish coal mining industry.

The model includes non-technical parameters such as production pressure and contracting practices, which have long been debated in the industry. These concepts are complex to incorporate in quantitative models and are generally only mentioned in expert reports. In this study, these phenomena are embedded in the model with quantified algorithms.

Hence, this study suggests a new approach to understanding catastrophic incidents in the Turkish coal mining industry by seeking endogenous explanations of the processes that accumulate potential for producing new disasters.



## **CHAPTER 2**

### **LITERATURE REVIEW**

#### **2.1 Introduction**

This section first overviews uncertainty assessment methods that can be used to evaluate occupational health and safety problems, classifying them into linear and nonlinear approaches. System dynamics modeling, as the primary evaluation method of the current study among the nonlinear approaches, will be discussed in detail. The applicability of system dynamics modeling in diverse fields will be explained to reveal its capabilities in solving complex and nonlinear cases.

#### **2.2 Uncertainty Assessment Methods for Occupational Health and Safety Cases**

Uncertainty assessment is crucial in improving the effectiveness of occupational safety and health (OHS) initiatives by clarifying risks, guiding decision-making, informing policies, and promoting a safer work environment for workers. It assists in identifying and evaluating uncertainties associated with occupational hazards, exposure levels, and health risks. Many tools for uncertainty assessment are available in the context of safety and health. These methods have been used interchangeably in the workplace for incident investigations. Depending on how the interactions are held within the system boundaries according to their linearities, they can be classified into linear and nonlinear approaches.

### 2.2.1 Linear Approaches

The conventional understanding of uncertainties has been evaluated linearly in many different cases. Here, linear points to a relationship between system variables that follows straight, predictable, or proportional patterns. Linear systems exhibit characteristics where changes in one variable produce directly proportional changes in another, leading to easily predicted or modeled outcomes.

Occupational safety and health problems can be linked to the causality perspective for accidents, which has been predominant since the 1930s. The widespread model of domino tiles was first suggested by Heinrich (1931) and utilized extensively by other researchers (Figure 2.1). According to this model, events causing the accident occur sequentially, culminating in the accident itself. Often likened to a line of falling dominoes, this model implies a single or multiple trigger, the root cause(s), initiating a chain reaction, much like the first domino that sets off a sequence of falling ones.

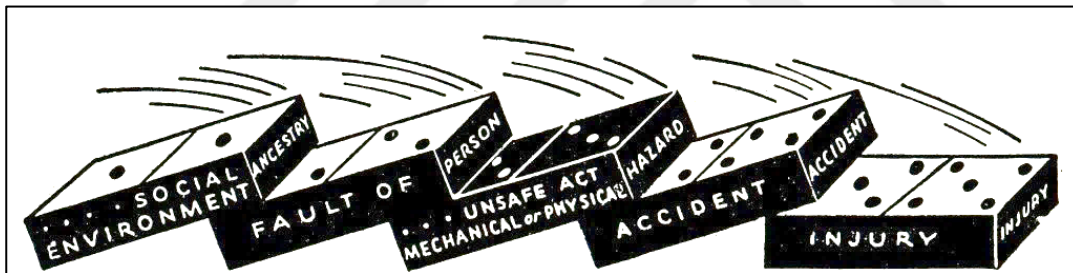

Figure 2-1. The domino model by Heinrich (1931)

As summarized by Dekker et al. (2008), this idea forms the basis of many risk analysis methods, including fault-tree analysis (FTA), failure mode and effect analysis (FMEA), and critical path models. Regardless of whether the method is qualitative, semi-quantitative, or quantitative, a model that depicts the formation of a failure in a series of events that are tied together with cause-and-effect relationships shows the characteristics of a linear understanding. Therefore, according to the linear accident causation models, one should interrupt the accident sequence by dealing with the underlying causal factors. As accidents are the outcome of those cause-

effect relationships, it should be possible to eliminate the outcomes by eliminating their causes firsthand. Consequently, predicting the potential causes becomes the key to preventing accidents. Conventional risk analysis methods are developed with this mindset predominant.

Busch (2018) cites several authors who critique the linear approach in accident causation while discussing why Heinrich chose the domino model. He asserts that traditional, linear approaches that attempt to control risks through compliance and technical measures are no longer sufficient. Still, these methods simplify the understanding and enhance the development of practical tools. However, the developed cause-and-effect relationships overlook the interactions throughout the timeline when tackling the problems arising from the complexity of systems.

### **2.2.2 Nonlinear Approaches**

In systems thinking, nonlinear refers to systems or relationships between variables that do not follow a straight or predictable pattern. Nonlinear systems exhibit characteristics where changes in one variable do not produce directly proportional changes in another, and the system's behavior is not easily predicted based on simple cause-and-effect relationships. The complexity of systems includes the intricate relationships between variables and their effects on each other concerning time.

The problem of complexity and linearity was discussed by Perrow (1984). In his *normal accident theory*, system accidents are suggested to be the outcomes of the interactions between complex system variables rather than the results of discrete events. The accidents in complex and tightly coupled systems were labeled as normal accidents. As cited in Toft et al. (2012), Rasmussen (1990) also extensively discussed the challenge of determining causality in accident analysis, drawing on philosophical concepts related to the connection between direct cause-effect relationships, timelines, and accident modeling. The study explored the difficulty of breaking down real-world events and objects to elucidate a causal path leading

upstream from the immediate accident, where latent effects from earlier events or actions remain dormant. It was also stated that socio-technical systems are both intricate and unpredictable.

According to Dekker et al. (2008), safety-critical systems are becoming increasingly intricate with increasing uncertainties due to the rapid technological developments in diverse areas. As the complex and nonlinear interactions between the system components increase, nonlinear methods have become essential to highlight and evaluate the levels of interactions. On this basis, when safety models involve complex and nonlinear relationships among variables, where input changes do not result in proportional changes in safety outcomes, the nonlinear models must explain the failures and the leverage points to address them. Accordingly, the system-theoretic accident model and process (STAMP) and system dynamics (SD) modeling have become well-known approaches to adopt when tackling safety in complex systems.

#### **2.2.2.1 Systems Theoretic Accident Model and Process (STAMP)**

As summarized in Toft et al. (2012), the system theoretic accident modeling and process approach (STAMP) was first developed by Leveson (2004) and evaluated systems considering interrelated components in dynamic equilibrium through feedback loops of information and control. It emphasized the need for safety management systems to oversee tasks and continuously impose constraints to ensure system safety. This model focused on understanding why existing controls fail to detect or prevent changes that lead to accidents. It employs a classification of flaws method to identify contributing factors within a linked system. Although it expanded on the barriers and defenses approach for accident prevention and emphasized proactive safety performance indicators, it had limited adoption within the safety community.

As Leveson and Thomas (2018) state, STAMP is not an analytical method but operates as a framework or a collection of underlying principles outlining how accidents occur. As a commonly utilized STAMP-derived tool, STPA (System Theoretic Process Analysis) serves as an uncertainty assessment method examining potential causes of accidents during the developmental phase to eliminate or manage hazards preemptively (Figure 2-2). STPA leans more towards a qualitative approach, focusing on understanding the system's structure, interactions, and control mechanisms, which might limit its ability to provide quantitative predictions.

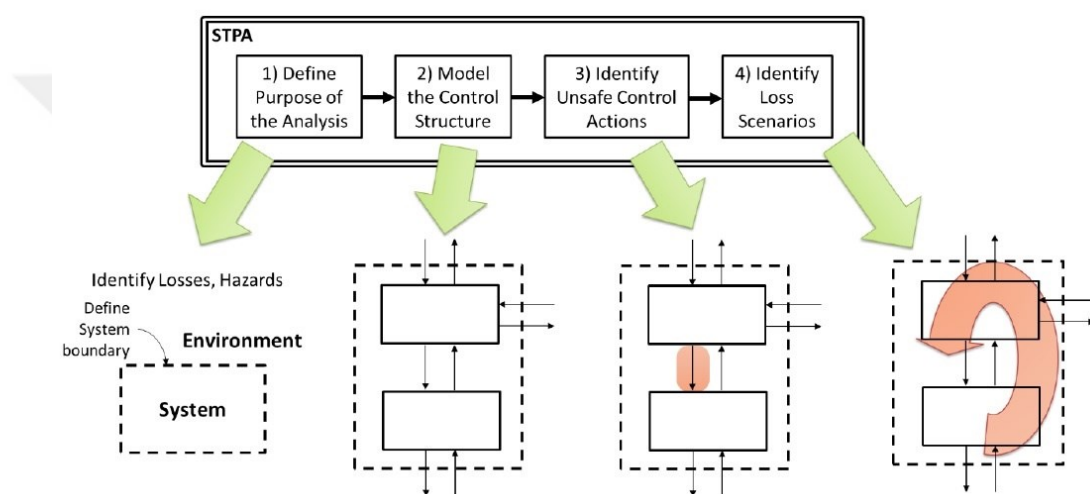

Figure 2-2. The overview of the STPA method (Leveson and Thomas, 2018)

### 2.2.2.2 System Dynamics Modelling

The system dynamics concept was first developed in the 1950s by Professor Jay Forrester at MIT to assist decision-makers in understanding the structure and dynamics of complex systems, developing effective policies for long-lasting improvement, and promoting successful implementation and change (Sterman, 2002). System dynamics provides a framework for addressing dynamic complexity, where the relationship between cause and effect may not be clear. It is based on nonlinear dynamics and feedback control theory using aspects from cognitive and

social psychology, organizational theory, economics, and other social sciences, and it establishes formal mathematical models, tests them, and provides a simulation to describe complex systems with nonlinear and dynamic features.

This method is specifically designed to model and analyze complex systems and provides a way to represent them in a graphical form. It utilizes stock and flow diagrams and causal loop diagrams to analyze the system's behavior over time. In this way, the behavior of complex systems under different conditions can be simulated to understand the underlying causes of observed behavior.

Sterman (2000) states that although each study has a diverse approach to SD modeling, a sequence of activities is universal for a successful modeling process, as listed below and illustrated in Figure 2-3.

- i. Defining the problem to be addressed,
- ii. Developing a dynamic hypothesis or theory about the causes of the problem,
- iii. Constructing a simulation model to test the dynamic hypothesis,
- iv. Iteratively testing and refining the model until it is deemed suitable for the intended purpose and
- v. Designing and evaluating policies or interventions to improve the system's performance based on the insights gained from the model.

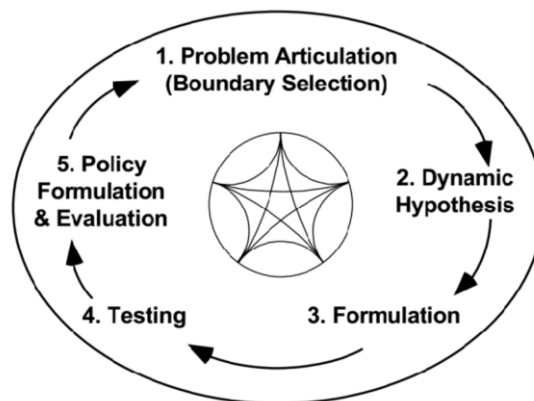
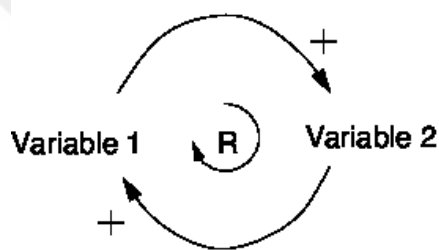
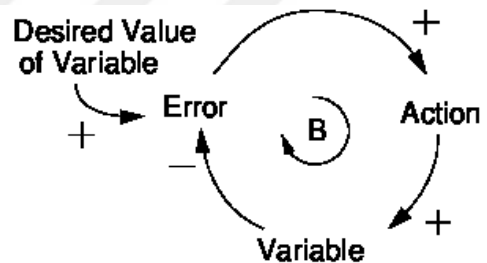

Figure 2-3. The Overview of SD Modeling Process (Sterman, 2000)

As Senge (1990) depicts, recognizing the loops rather than linear relationships can be the key to systematically conceptualizing reality. Even though it seems like a basic concept, recognizing the feedback loops overthrows deep-rooted perceptions such as causality. System dynamics, therefore, uses feedback loops, stocks and flows, and nonlinearities resulting from system component interactions to model the behavior of a system. The models used in this approach are built from three fundamental components: reinforcing loops (also known as positive feedback), balancing loops (also known as negative feedback), and delays (Figure 2-4). Reinforcing loops amplify the change while balancing loops tend to counteract it. Delays can introduce instability to the system (Leveson et al., 2006).



a. A Reinforcing Loop



b. A Balancing Loop

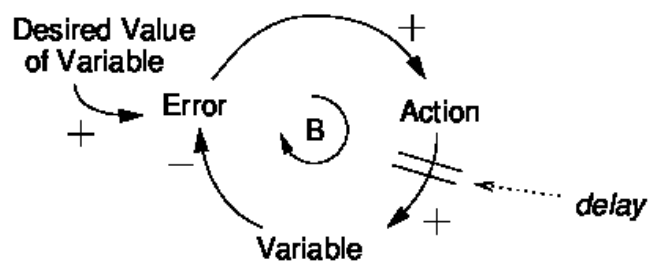

c. A Balancing Loop with a Delay

Figure 2-4. Three Basic Components of SD Models (Sterman, 2000)

#### **2.2.2.2.1 Defining the Problem**

All modeling efforts should address a real-world problem that needs to be solved. In this sense, articulating a real-world problem is a crucial starting point for system dynamics modeling. In defining the problem, Sterman (2000) suggests that modelers should adopt a concise approach, excluding irrelevant components. This approach is crucial to ensure the feasibility and promptness of the project.

Featherston and Doolan (2012) reviewed the critics of SD and summarized them under four categories. Two of these categories are concerning the problem definition phase. Firstly, the nature of the problem should be compatible with system dynamics modeling. An SD model aims to understand the problems as dynamic patterns unfolding over time. Applying it to the problems that emerged mainly due to extrinsic influences may result in poor models. Barlas (2007) emphasizes that modelers should use system dynamics to solve system dynamics problems. For static complexity cases, point forecasting problems, and input-output (I-O) simulations, other modeling methods are a better fit than system dynamics. To ensure good problem articulation, Sterman (2000) recommends creating reference modes and exhibiting the problem on a time horizon that extends back far enough. Thus, the modeler should ensure that the defined problem results from the dynamic complexity and, therefore, it is a good fit for system dynamics.

Another common mistake in this phase is trying to build models that are too large to represent each and every component in a system. Barlas (2007) asserts that assuming that incorporating more details and building large models results in a more valid model is counterfactual, and it is not only challenging to build sizable models, but also it is almost impossible to understand, test, and evaluate them. So, the model should include only the essential details that clearly fit with the articulated problem.

#### 2.2.2.2.2 Developing A Dynamic Hypotheses

After the definition phase, the conceptualization efforts continue with building a hypothesis to explain the problem, called the dynamic hypothesis, as the problem is conceptualized in terms of system elements. A dynamic hypothesis explains the emerging problem based on feedback loops and stock and flow structure.

The process itself is somehow dynamic, as working with those who own the problem and improving the hypothesis with their feedback is essential. In this phase, it is also advisable to approach the process of conceptualization with creativity and multiple perspectives, avoiding a strict division between the identification and conceptualization phases (Martinez-Moyano and Richardson, 2013).

It is crucial in that stage to have a systems thinking mindset and seek endogenous explanations rather than exogenous ones. In systems thinking, the cause of problems is hidden in the complex dynamic interactions between system components. In other words, factors inside the defined system boundaries are more decisive in the problem than those influencing the system outside the boundaries. Even though exogenous factors can be included in the model to some extent, Sterman (2000) warns modelers to scrutinize their importance and carefully reconsider model boundaries accordingly. The SD tools include model boundary, subsystem, causal loop diagrams, and stock-and-flow charts to develop the dynamic hypothesis.

##### Model Boundary Chart

Model boundary charts in system dynamics emphasize the distinction between endogenous, exogenous, and excluded variables. This distinction is visualized using a simple chart or diagrams like the Bullseye, where the center represents endogenous variables, the middle ring represents exogenous variables, and the outer ring represents excluded variables. Trimble (2014) states that the iterative nature of developing system dynamics models is guided by examining these boundary

concepts for model improvement and extension. An example model boundary chart is given in Table 2-1.

Table 2-1. An Example Model Boundary Chart (Sterman, 1983)

<b>Endogenous</b>	<b>Exogenous</b>	<b>Excluded</b>
GNP	Population	Inventories
Consumption	Technological change	International trade
Investment	Tax rates	Environmental constraints
Savings	Energy policies	Non-energy resources
Prices		Interfuel substitution
Wages		Distributional equality
Inflation rate		
Labor force participation		
Employment		
Unemployment		
Interest rates		
Money supply		
Debt		
Energy production		
Energy demand		
Energy imports		

Table 2-1 lists the factors related to a complex problem that explores the impact of higher energy prices on macroeconomic variables and the development of novel energy sources (Sterman, 1983). Notably, the endogenous variables outweigh the exogenous ones, while there are still several exogenous variables in the model. It was mentioned in the study that taking these exogenous variables as endogenous would impair the conciseness of model boundaries.

### Subsystem Diagram

A subsystem diagram provides an overview of a model's structure, displaying significant subsystems and the flows linking them. Subsystems can represent organizations or their subunits, such as operations or marketing. These diagrams convey information about the model's boundaries and level of detail by showing the

number and types of organizations involved. They also offer insight into the model's endogenous and exogenous variables.

For example, Cooke (2003) defined four subsystems in modeling the Westray Coal Mine system. Accordingly, a model addressing the systemic structure behind a coal mine explosion was constructed with four subsystems: production, human resources, mine capacity, and safety, as illustrated in Figure 2-5.

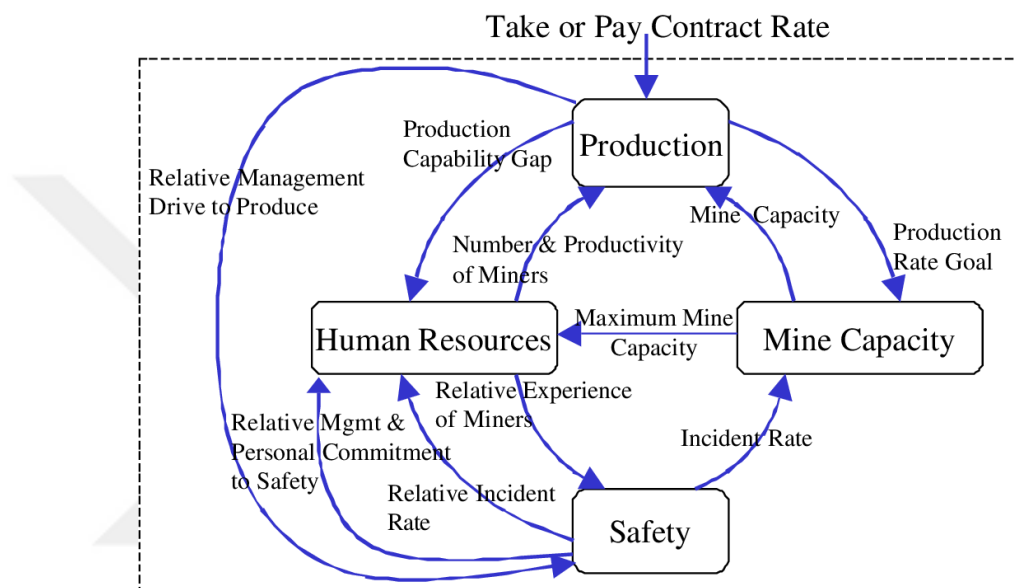

Figure 2-5. Subsystems of the Westray Coal Mine Explosion (Cooke, 2003)

### Causal Loop Diagrams (CLDs)

Causal loop diagramming is often considered the qualitative foundation of system dynamics modeling. These diagrams help modelers and stakeholders understand the underlying dynamics and feedback loops that drive system behavior. Once these qualitative relationships are established, they can serve as the basis for building more quantitative models that simulate the system's behavior over time using mathematical equations.

According to Sterman (2000), CLDs are excellent for swiftly capturing dynamic hypotheses, drawing out and recording mental models, and showing significant feedback loops that can be responsible for the problem. The essential components of

the causal loop diagrams are already shown in Figure 2-4. These components establish causal loop diagrams. There are slightly different notations used in the literature. However, link polarities are commonly used to show the nature of changes in the relationship. In a causal relationship, a negative link shows that if the cause increases, the effect decreases as a result. In contrast, a positive link shows that if an increase occurs in the cause part, this time, the effect increases resultantly.

Eleven crucial aspects that should be regarded when building causal loop diagrams are listed as follows (Sterman, 2000):

- i. Causal relationships in the model should be used, and any confusion correlating with causation should be avoided.
- ii. The link polarities should be labeled.
- iii. The loop polarities should be determined, and polarities must be certain.
- iv. Loop names need to be used to enable readers to follow.
- v. The significant delays should be expressed in causal links.
- vi. Proper variable names should be used. The variable names need to be either nouns or noun phrases. They should have a clear sense of direction, and this direction should be positive.
- vii. A clear and understandable layout should be built.
- viii. An optimum level of detail, which enables readers to grasp the logic while at the same time keeping the structure simple and clear, should be used.
- ix. A series of small CLDs should be constructed rather than merging all the information to build one comprehensive diagram.
- x. The goals of balancing loops should be shown explicitly, as they all have a goal.
- xi. A clear distinction between the true state and the state perceived by the actors should be made.

When constructing causal loop diagrams, it is advisable to supplement the understanding with as much data as possible. Interviews are essential data sources but have limitations. Therefore, additional qualitative and quantitative data should be used depending on the problem defined.

### Stock and Flow Maps

Stock and flow maps can incorporate quantitative aspects into the model using differential equations. The flow and accumulation can be visualized as a material flowing in and out of a container. According to Sterman (2000), in addition to the feedback loops, stocks and flows are another fundamental concept in system dynamics theory. Although stocks and flows are everywhere, many decision-makers fail to distinguish them. Therefore, defining the system's stocks and flows is vital while building the model.

By definition, past events are accumulated in stocks. The manufactured goods are stocked in the inventory, the customer orders to be dispatched are stocks, and the number of miners hired for production can also be shown as stock. These stocks can only alter through inflow and outflow. The goods in the inventory will fall when the dispatching rate is higher than the production rate, and the periodic number of miners will increase when the hiring rate of the company is higher than their leaving rate. In the diagrams, the regulators of inflows and outflows are denoted as valves. For example, the production rate controls the inflow to the inventory, and the shipment rate controls the outflow from the inventory (Figure 2-6). However, these valves controlling inflow and outflow will depend on different variables.

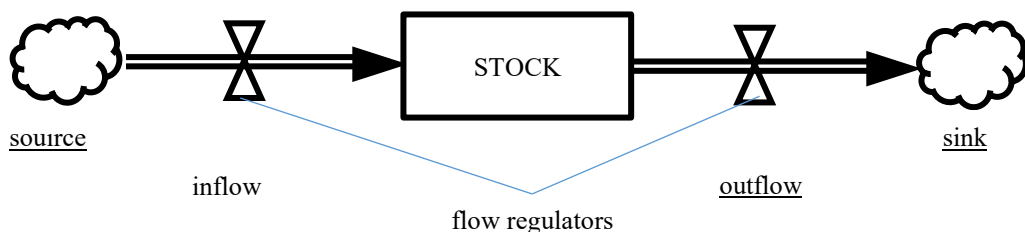

Figure 2-6. A Sample Stock and Flow Illustration

### Policy Structure Diagrams

A policy structure diagram is a visual representation used in system dynamics modeling to illustrate the relationships between various policies, actions, and their intended outcomes within a complex system. It helps in understanding how policies interact with each other, how they influence the system, and the potential outcomes they generate.

This diagram typically shows the causal relationships between different policies and their effects on key variables or aspects of the system. It helps the modeler visualize the interconnectedness between policies and identify potential unintended consequences, leverage points, and feedback loops within the policy system. A policy structure diagram is a tool to analyze and communicate the complex web of policy interactions within a system. Construction of the Simulation Model

Simulation models work with iterative actions. Therefore, system dynamics modeling should be a process that develops by continuous testing and questioning (Sterman, 2000). The causal model is built with the defined parameters inside the boundaries. The causal loop model is qualitative and consists of feedback loops.

Mozier (1999) summarizes the simulation model construction into two steps after building a causal model. The first step is converting the causal model into a flow model, which enables the model to be quantified. The second step is to transcribe this flow diagram into computer language to use iterations and dynamic testing of the model.

The quantitative model is formed using mathematical equations that run forward in time in system dynamics modeling. The stock-and-flow diagrams represent the flows accumulated in stocks with differential equations. Different computational tools have been developed for system dynamics models. Vensim, Stella, NetLogo, Powersim, Studio, and Anylogic are the most commonly used SD software.

### **2.2.2.2.3 Testing and Refining the Model**

To address the leverage points correctly, the modeler should test the model in terms of its explicability in real life. According to Sterman (2000), the testing process starts with the very first equation of the simulation model. It involves more than comparing simulated and actual system behaviors, necessitating meaningful real-world variables, dimensional equation consistency, and assessing sensitivity to uncertainties in assumptions for both model behavior and policy recommendations. Models must endure testing under extreme conditions, often scenarios that haven't been observed in reality. Developing confidence in the model lies in its testing capability. The modeler refines the model as the feedback from the testing shapes the enhancements.

### **2.2.2.2.4 Designing and Evaluating Interventions**

The evaluation phase of the system dynamics modeling involves the development of potential interventions. Evaluation helps verify the model's accuracy by comparing its behavior against real-world observations or data. It is conducted to ensure that the model effectively represents the system's dynamics and behavior. Evaluation allows researchers to determine the reliability and credibility of the model's predictions and outputs. Identifying areas where the model may deviate from reality provides insights for refining or enhancing the model. As system dynamics models are often used to explore the effects of different policies or interventions, Mozier (1999) suggests adopting sensitivity analyses to test the model behavior under the effect of different conditions. This approach focuses on searching for the system's leverage points and enables the modeler to suggest a policy design.

### **2.3 Application Fields of System Dynamics Modelling for Complex Systems**

Complex systems exhibit nonlinear and dynamic behavior and are composed of interconnected elements interacting with each other in feedback loops. The Complex Systems Theory was initially formulated by Von Bertalanffy (1969), aiming to establish an alternative to the Newtonian–Cartesian perspective to explain complex events and systems. Complex systems can be recognized in many areas, and their theory is applicable to a vast domain. Indeed, the whole world can be defined as a complex system where everything is connected to everything else (Sterman, 2000). Therefore, the boundaries and content of a complex system to be analyzed should be clarified to distinguish its difference from other basic linear systems. This separation requires a complete understanding of what a complex system stands for. Accordingly, the features of the complex systems are summarized by Dekker (2011) as follows:

- i. Complex systems are susceptible to the effect of their surroundings and can affect their surroundings in return,
- ii. Components of the complex systems have a sort of autonomy in a way that each of them is uninformed about the total effects of their actions on the system as a whole,
- iii. A complex system cannot be fully represented by the behavior of any components in the system as the complexity feature is affiliated with the system itself,
- iv. The conditions are dynamic in which complex systems operate,
- v. There is a time dependency for complex systems, so the historical characteristics should be considered when describing the current behavior,
- vi. The components of a complex system have nonlinear relationships with each other, and these relationships can produce asymmetrical results.

In the Normal Accident Theory, Perrow (1984) also states that complexity and linearity apply only to the systems' interactions by avoiding defining the whole system as complex or linear. Therefore, linear and complex interactions are utilized instead of linear and complex systems. In normal accidents theory, the systems are compared on a two-variable array in which the complexity/linearity of interactions and the tightness/looseness of coupling are combined in a chart (Figure 2-7). The chart classifies the mining sector as a loosely coupled complex system.

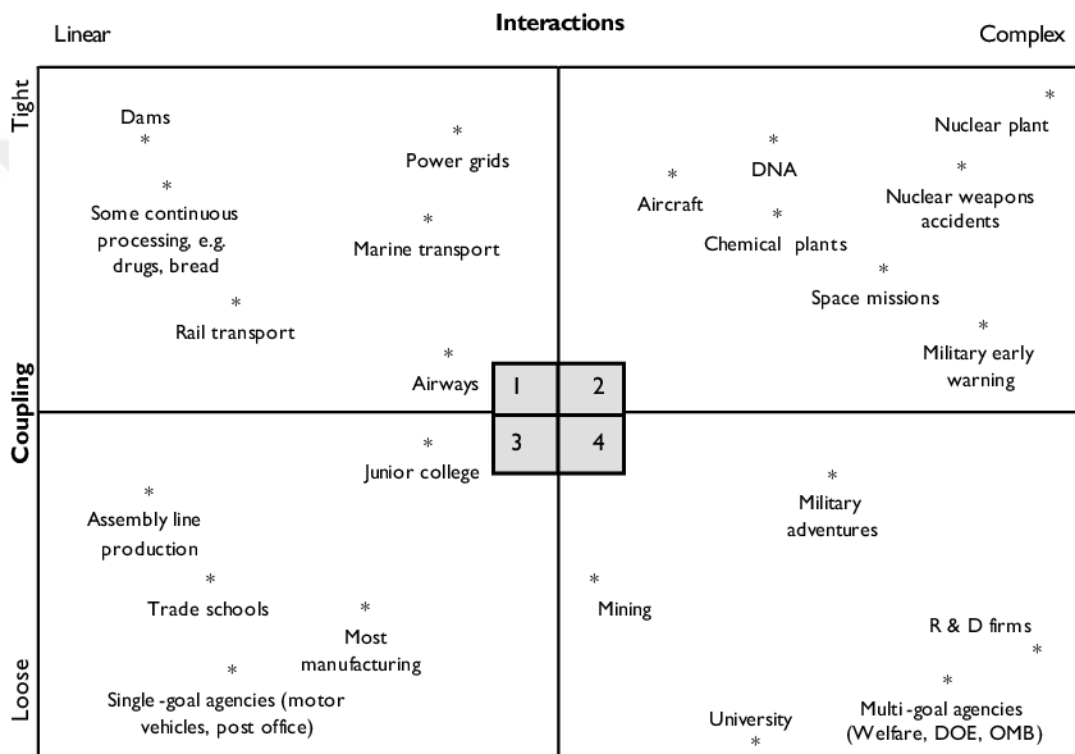

Figure 2-7. Interaction/Coupling Chart (Perrow, 1984)

Accidents are grouped as system and individual accidents (Perrow, 1984). System accidents occur due to systems' inherent complexity and coupling, making their prediction and control difficult. These accidents induce widespread and long-lasting consequences, affecting not only the immediate system but also other third-party systems and individuals. These accidents are generally observed as inevitable in complex systems and cannot be prevented entirely. Management and mitigation of consequences are applied to reduce risk levels.

On the other hand, individual accidents are caused by the actions or errors of individual people, such as operator error, negligence, ignorance, or intentional misjudgments. These accidents are comparatively more practical to prevent and control than system accidents since human factors and risk levels typically cause them, and they can be reduced through training, regulation, and other interventions. Evaluating system and individual accidents in a complex system can be challenging since various complex and mutual interactions are expected to occur. As mentioned in Section 2.2, system dynamics modeling is a robust technique for successfully explaining complex systems. This section will concentrate more on general applications of system dynamics on complex systems other than mining to highlight its effectiveness in modeling a diverse range of applications in different fields. The complexity of the safety systems of the mining sector will be detailed in Section 2.4.

In the literature, the complexity aspects have been handled primarily for the branches of transportation, health care, management science, environmental science, and human factors and safety science, where high levels of uncertainty related to technical, management, environmental, and human aspects are available. Accordingly, various review articles concentrating on these application fields of system dynamics are available in the literature. Therefore, this section will discuss the details in these articles, while a deeper analysis of system dynamics for safety issues in mining-related sites will be evaluated under Section 2.4. In addition, Torres (2019) and Zanker et al. (2021) reviewed the study scopes dominating system dynamics applications.

Torres (2019) reviewed articles on system dynamics published between 1985 and 2017. The review performed bibliometric analysis to classify more than 1,400 research articles. The citation analysis revealed that system dynamics is an emergent field of study, as citations show a significant upward trend, especially after 2001. The author identifies three broad categories of research: i) developing formal procedures for system dynamics, ii) modeling dynamic problems of interest, and iii) group model building for developing models. The widespread problems of interest

for the second category are global warming, sustainable development, drug use dynamics, conservation policies, water scarcity, and disasters, including coal mine explosions. The analysis also reveals the main themes in research by clustering the journals. In Figure 2-8, the green cluster depicts operations research and management science; the red cluster shows environmental analyses, the yellow cluster shows healthcare applications, and the blue cluster depicts the general applications of SD modeling. Torres (2019) gives three suggestions for future research in system dynamics. First, future research should focus more on the underlying mechanisms of human misperceptions and misunderstandings of the dynamics of a feedback system in decision-making. Second, scholars should demonstrate the effects of system dynamic interventions in the long term. Finally, more studies should focus on providing decision-makers with procedures to build their simulation models.

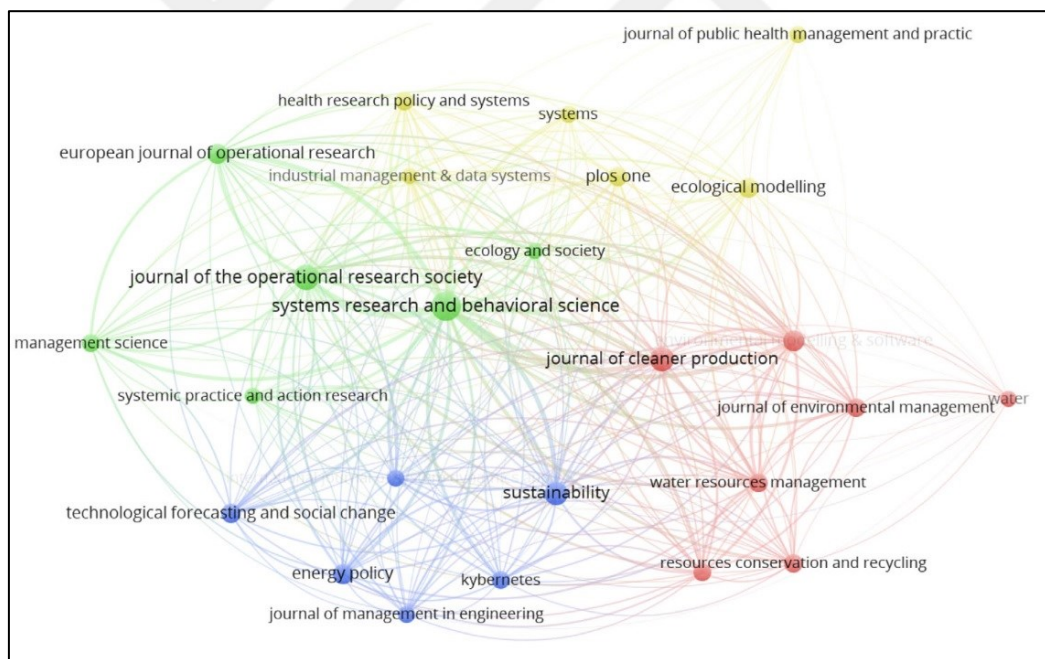

Figure 2-8. Bibliographic Coupling Network Map Based on Journals Showing the Themes of System Dynamics Researches Torres (2019)

Zanker et al. (2021) conducted a systematic review of the application domains of system dynamics in recent years. The authors examined 212 papers published between 2016 and 2019 for the study. The review gives a classification chart of recent trends in the SD research that presents the research areas under 20 subgroups of 4 main classes. Recent studies have focused on the environmental and business domains, while the health domain is also visible. The study indicates that Vensim is the predominant software, whereas Stella, NetLogo, Powersim, Studio, and Anylogic are other common computational tools for building SD models. Researchers have developed the vast majority of the models to make predictions using the dynamic simulation feature of SD. Business performance, mineral/material markets, and transportation safety are popular topics under the business domain predictions. In the environmental domain, leading topics are sustainability, pollution, and water resources. However, the authors highlight the importance of model verification by using tests and criticize that some recent studies need more clarity in their methodologies. Figure 2-9 shows the frequencies of test methods adopted in the studies. As a result, the researchers should verify the robustness and meaningfulness of their models/simulations to enable grounded analyses and predictions.

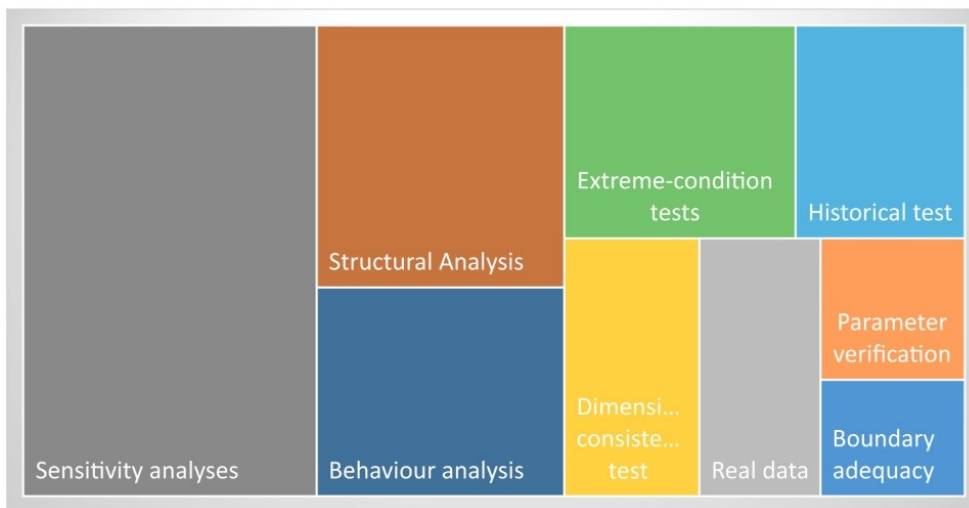

Figure 2-9. Frequencies of Tests Conducted in SD (Zanker et al., 2021)

The review articles and the search inquiries in WOS and Scopus revealed that system dynamics applications are accumulated in transportation, healthcare, management science, environmental problems, and analysis of human factors and related safety issues. Accordingly, the subheadings under this section will discuss how the system dynamics models are adopted to implement these fields.

### **2.3.1 Transportation**

Shepherd (2014) reviewed the scientific studies that use system dynamics in transportation areas. The paper analyzed more than 50 peer-reviewed articles between 1995 and 2013. The review reveals that system dynamics mostly appear in urban, regional, and national strategic transportation policies. For instance, transferability between cities and the potential impacts of a specific highway capacity enhancement can be studied to support decision-making stages in the area. The review covers a period in which exploring different policies to promote alternative fuel vehicles has been attractive; therefore, unsurprisingly, a significant portion of the reviewed articles were on this topic. Although the scope of Shepherd (2014) returns only one paper on transportation safety, more studies should adopt system dynamics in traffic safety and aviation safety domains, as Ibrahim Shire (2018) states.

Fontoura and Ribeiro (2021) reviewed the papers on sustainable transportation policies. The authors claimed that transportation systems should not be analyzed with linear approaches due to their dynamic complexity, as Wang et al. (2008) also suggested. This review article discussed 23 papers primarily published after 2013 without restricting the publication period. Almost all these studies used SD to analyze their proposed policies by incorporating an environmental sub-model, in which air pollutant emissions and energy consumption values are used as sustainability indicators.

### 2.3.2 Healthcare

Davahli et al. (2020) conducted a systematic literature review of research on the use of system dynamics in healthcare. The article investigated the main problems addressed in past research, the modeling approaches, and the prospect of SD simulations in healthcare. Reviewers examined a total of 253 articles published between the years 2000 and 2019. The use of SD in healthcare-related studies, like in other sectors, shows an ascending trend in the literature after 2013. Patient flow was the most popular research area in which the majority of analysts adopted a quantitative approach by establishing stock and flow diagrams and using more quantifiable key variables such as the number of patients awaiting discharge, patients in care, patients waiting for rehabilitation, length of stay, or bed capacity. Figure 2-10 shows a sample portion of a stock and flow model used to evaluate the patient flow. The systematic review found that other popular research areas include specific disorders such as obesity and communicable diseases such as HIV/AIDS and tuberculosis. However, safety in healthcare sectors is another research area that is not frequently studied.

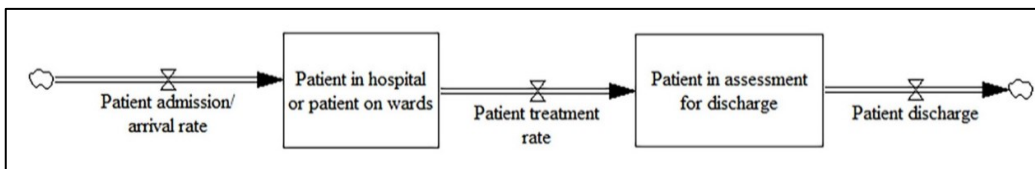

Figure 2-10. The Core Part of the Stock-Flow Diagram for the Patient Flow Model by Davahli et al. (2020)

Darabi and Hosseinichimeh (2020) expanded the publication period to 1960-2018 and analyzed 301 articles on SD modeling in health and medicine. It is again observed that SD studies have been populated after the mid-2010s. The authors classified the papers into three main modeling categories: i) disease-related, ii) organizational, and iii) regional health. Most of the research studies have concentrated on the first and third categories.

### 2.3.3 Management Science

Cosenz and Noto (2016) systematically reviewed the articles on the system dynamics used in modeling strategic management. The authors described strategic management as a broad term for top management's decision-making process, which recognizes assessing the organization's environment. By examining 172 articles, they showed that scholars used system dynamics as a systemic analysis tool, and 63% of the studies included simulation in the related fields. According to the review, analyses adopt system dynamics mostly in strategic planning, organizational learning, and performance management. It was emphasized that SD is a flexible strategic management tool with solid educational features for managers.

The system dynamics applications in electricity sector modeling were reviewed by Ahmad et al. (2016). Examination of selected 35 papers showed that most of the studies focused on policy assessment and generation capacity expansion modeling. The study shows that system dynamics is a valuable tool for exploring the possible effects of new policies on the national level. It also features the use of SD in combination with other modeling approaches. These approaches included artificial intelligence techniques such as genetic algorithms, decision trees, and agent-based modeling.

Uriona and Grobbelaar (2019) analyzed the research studies on innovation system modeling with SD. The studies are generally interested in business management research and development efforts. Reviewing 54 papers published between 1996 and 2017, the authors claim that most researchers adopted system dynamics as an explorative model with no specific real-world problem. The models mostly aim to form an understanding of innovation system feedback upon different policy changes. Even though system dynamics is considered beneficial for the policy recommendations, incorporating non-traditional actors into the models is not concentrated. Integrating system dynamics modeling with agent-based or bottom-up modeling approaches is advised for future research to address this gap.

### 2.3.4 Environmental Sciences

System dynamics use in agricultural and natural resource (AGNR) management modeling was reviewed by Turner et al. (2016) by examining the case studies. The article mentions that the first ever SD model on AGNR was as early as 1972 to explore the upper limits of human developmental capacity by building an SD model based on population growth, food per capita production, non-renewable resource depletion, industrial output, and pollution generation parameters. Since then, there have been prevalent case studies on hydrology and water resources, agriculture, land and soil resources, food system resiliency, and smallholder development topics. The authors discussed the case studies and the system archetype behaviors of the models. Accordingly, the complexity of environmental sciences constitutes a convenient domain for system dynamics modeling. For the case studies reviewed, *fixes that backfire* and *drifting goals* are the two most common archetypes, revealing that quick fixes tend to fail in their specific contexts. It is also seen that dynamic concepts of resilience, sustainability, and robustness are described on a time-dependent graph in the context of food resilience. Figure 2-11 portrays that incomplete system recovery after a disturbance results in a sustainably reduced system capacity. The authors describe this behavior as compatible with the drifting goals archetype.

Koul et al. (2016) reviewed papers that utilized system dynamics in hydrocarbon resource extraction. The reviewers define four levels of uncertainty and argue that system dynamics have limitations under deep uncertainties. According to the article, the deep uncertainties are the type in which the only known is that researchers do not know. Researchers suggest testing different scenarios with varying assumptions to overcome decision-making difficulties in policy changes about hydrocarbon resource extraction. In the study, exploratory modeling and analysis methodology (EMA), agent-based modeling (ABM), and patient rule induction method (PRIM) are suggested methods to improve the ability of the system dynamics to model under deeply uncertain conditions.

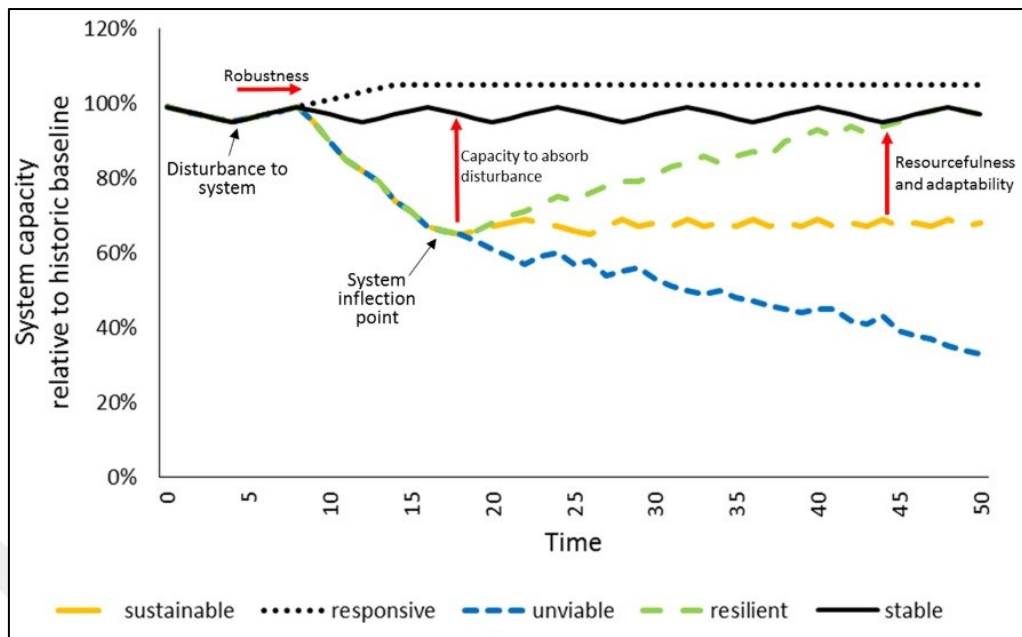

Figure 2-11. Food System Resilience Concept (Turner et al., 2016)

### 2.3.5 Human Factors and Safety Science

Shire et al. (2018) systematically reviewed the literature addressing system safety using system dynamics. The review was scoped to investigate what safety issues SD addresses, what safety improvements SD serves, and how SD might further contribute to system safety. The authors summarized the nonlinear methods developed to understand accidents in complex socio-technical systems. It was asserted that system dynamics have several advantages over Accimap, HFACS, FRAM, and STAMP methodologies, which frequently utilize causal analysis methods. These advantages are that i) system dynamics can be used for retrospective analysis and predictive assessments, ii) SD models give users unlimited options to define their model categories, iii) the visual interpretations are easy to understand, and iv) SD can produce successful quantified models even in the case of scarce data. Also, sensitivity analyses, testing, and qualitative interpretations can address uncertainties.

Shire et al. (2018) identified 63 articles from 1984 to 2017 and classified them according to their application area using an extended version of the HFACS framework. More than a third of the papers were detected to be from the healthcare sector. It is realized that the potential of system dynamics in safety decision-making is generally underestimated.

Kontogiannis and Malakis (2019) tried to represent the efficiency-thoroughness trade-off (ETTO) principle regarding system dynamics. The ETTO principle, hypothesized by Hollnagel (2009), provides insight into the decision-making process at the sharp end while people try to maintain safety under pressure. For example, operators facing a high volume of information need to process as much data as possible. While doing this, they employ techniques that may sacrifice accuracy and thoroughness to develop a solid understanding of the situation and respond promptly. The researchers used *compensation tactics* and *exploration studies* concepts to represent the principle. Here, the compensation tactics refer to the performance adjustments of operators in favor of efficiency, while exploration studies refer to the efforts seeking thoroughness. They presented a qualitative model of the ETTO principle and simulated it to explore the system's dynamic behavior. The proposed model is generic, and it lacks validation with real-world data. Figure 2-12 illustrates the causal loop diagram of the ETTO principle.

As systems thinking is more pronounced in safety science, applications of system dynamics to occupational health and safety are also emerging. The background information and its detailed explanation of how the system dynamics can be embedded into OHS-related mining aspects will be detailed in Section 2.4.



## **2.4 System Dynamics Applications for OHS-Related Aspects in Mining**

This subsection discusses applications of the system dynamics method to evaluate and solve OHS-related problems in mining sites. Accordingly, Cooke (2003) used the system dynamics approach to analyze the 1992 Westray coal mine explosion in Canada, which resulted in the deaths of 26 miners. Cooke's work presented an alternative to traditional accident investigation approaches that follow a linear process. The results showed that even loosely coupled linear organizations like the Westray coal mine can potentially generate disasters. The study's dynamic model comprised four subsystems: Production, human resources, safety, and mine capacity. A causal loop diagram demonstrated each subsystem. The study formulated causal relationships using the Public Inquiry Report and the archetypes based on the study by Sterman (2000). Overall, the structural model used a dynamic hypothesis that production priority over safety triggered the chain of events that resulted in the major incident. Although the explosion occurred after a year of operation, the model was simulated for 100-500 weeks from the start of the mine to analyze the long-run behavior of the system. Interviews and discussions were used for model validation. The author tested the dynamic model for four different scenarios based on "no incidents," "incident rates at industry average," "high losses from incidents," and "safety taken as the priority." According to the results, the author suggested that safety culture changes take a long time due to the significant delays in the model. The shortcomings of using incident rates as performance indicators may also stem from these delays. Cooke also claimed that safety commitment does not sustain itself, as it tends to decrease without incidents. Although the model results do not give groundbreaking conclusions, it was successful because it explained contemporary phenomena, such as the shortcomings of lagging indicators and the organizations' tendency to drift into failure. The study also shows that system dynamics can be a helpful tool for analyzing organizational accidents and creating options for future research.

Goh et al. (2012a) conducted another study in a similar context. They focused on the production vs. protection dilemma in mining by using system dynamics. The research approach in this paper was an instrumental case study to deduce more general principles. The existing theory was the base for establishing the model, especially Reason's (1997) work on how organizational accidents occur. A causal loop diagram demonstrates the production and protection subsystems interacting with each other. The authors chose a fatal rock fall accident involving seismicity that occurred in the Beaconsfield gold mine on 26<sup>th</sup> April 2006 as a critical case that has the potential to reveal information that might permit obtaining general principles. The authors also utilized qualitative data analysis software to analyze the information gathered from the coroner's inquiry and other investigation reports. The authors tested the compatibility of model results with five pre-selected statements derived from the literature. They discussed the results under three sections: theoretical implications, managerial implications, and methodological implications. The research findings indicate that when there is pressure to increase production, management tends to prioritize production over other aspects, leading to a distorted perception of risks and further emphasis on production. This vicious cycle is a significant factor in causing system accidents. Additionally, the study found that finding a balance between protecting against risk and increasing production can be tricky. Initially, increasing protection can lead to excessive emphasis on production, ultimately increasing the risk of accidents.

Goh et al. (2012b) used the system dynamics methodology in a qualitative research paper to interpret the causal relationship between safety culture and OHS performance. The study was conducted with participants from a large Australian international company providing diversified services in the mining industry. Researchers used a group model-building approach where the participants worked in pairs to build a model that could reveal the causal factors influencing OHS metrics. As a result, a causal loop diagram was produced using Vensim software to represent the findings. As the study scope is limited to form a descriptive model, it does not

incorporate a simulation model to determine leverage points for improving the OHS metrics. However, the potential of the group model-building approach in framing the causal loop diagram was shown by this study.

The emergency response capacity for coal mine flooding was studied by Wang et al. (2012) using a system dynamics model. A causal diagram analyzed and interpreted the success factors for rescue in flooding emergencies, and a flow chart model focused on "emergency capacity" forms the basis for the simulation. Researchers used flooding accident statistics and emergency input data, and safety management experts reviewed simulation results for verification. Wang et al. state that each factor has a different weight influencing the emergency capacity against flooding. The study offers a methodology to practically use system dynamics modeling in decision-making to improve the emergency capacity of a coal mine.

Another case study on the practical use of system dynamics in coal mine safety was done by Tong & Dou (2014). They used accident cost data from a coal mine in China to analyze the optimal allocation of safety expenditure to reach the accident cost targets. The authors formed a causal loop diagram and a stock and flow diagram to model the effects of safety investments. A simulation was run in Vensim software, and it was concluded that although safety expenditure has a delayed effect on safety, the higher the initial investment in safety, the shorter the time required to achieve targets. Researchers also proposed an optimal ratio combination for safety expenditures. Even though the theoretical background that forms the basis for the models has yet to be explicitly explained, the study shows a potential practical use of system dynamics in safety decision-making.

Rodriguez-Ulloa (2018) proposed an intelligent decision support system methodology for decision-makers in the Peruvian energy and mining sectors. The methodology is a combination of systems approach and artificial intelligence technology. To evaluate the risks in the complex interactions between human and non-human factors, the author offers system dynamics to unveil the causal

relationships in the modeling phase. However, instead of using stock and flow simulation of system dynamics, the methodology incorporates Bayesian networks in performing sensitivity and scenario analyses. Thus, the proposed methodology utilizes only the descriptive components of system dynamics.

Abbaspour et al. (2018) further tested system dynamics in safety decision-making in a study to evaluate the safety of different transportation system alternatives in open pit mines. They introduced safety and social indexes applicable only to the scope of this study when creating the causal loops and the stock and flow model. Researchers worked with the parameters of a hypothetical open pit copper mine to compare the safety and social indexes of different types of IPCC (in pit crushing and conveying) systems and conventional truck-shovel systems. The simulation results depicted that fully mobile IPCC systems produced significantly lower LTIFR and higher safety index. Regarding the social index, the truck shovel system and fixed IPCC system ranked higher as these systems require more workforce and training effort. Instead of determining one transport system as the optimal solution, the researchers suggest the importance of two indexes interchange throughout the life of mine. Therefore, different transportation methods may be optimal during different periods of the life of mine, according to the simulation results.

Yu et al. (2019) focused on the intervention strategies against unsafe behaviors of coal miners and used system dynamics to compare the effects of different intervention strategies on unsafe behaviors. Although the outdated concept of "unsafe behavior" was selected as the topic of the study, researchers made rigorous validation efforts for the model they structured. Ishikawa diagram was used to specify the influencing factors that lead to unsafe behaviors. The authors listed the specified factors under a relevant branch of the fishbone. An analytical network process (ANP) was utilized to appoint significant weights. These factors were evaluated against hazard perception, identification, and decision-making criteria. The resultant matrix was tested in Super Decision software for consistency by consulting an expert group. The established stock and flow model took account of

the weights of the indicators, and simulation was run for different intervention strategies and the initial state. The simulation showed that the coal miners' unsafe behaviors decreased until they reached a balance. The unsafe behaviors under different intervention conditions showed a similar pattern but a lower balancing point. Researchers also simulated the effects of adopting combined intervention strategies and suggested that coal mine enterprises first improve their safety management systems. They also asserted that unsafe behaviors do not thoroughly converge to zero.

Boukas & Kontogiannis (2019) aimed to model safety management by elaborating on the study conducted by Cooke (2003). The case study focused on the organizational tradeoffs affecting safety management. The article examined a typical mine, and researchers defined two indexes for production pressure to quantify the concept. The total desired work rate divided by capacity gives the "schedule pressure" index, and the production rate ratio to the actual customer orders gives the "management production pressure" index. The model incorporated four subsystems, safety, production, human resources, and task management, and included the complex interrelations between them. Researchers excluded the mine capacity subsystem, which is encompassed by Cooke's (2003) work, and introduced the task management subsystem as an indirect route where production influences safety. The suggested model contributed to the safety subsystem by involving the human reliability module. Figure 2-13 shows a simplified overview of causal loops given by two articles. The built model was simulated with different production order rates for five years to see the effects in the long run. Researchers also run extreme conditions tests and sensitivity analyses. The simulation results showed that working patterns are significant factors for all subsystems, and flexible working patterns effectively kept the schedule pressure reasonable even at high production demands. Researchers suggested that the rationale behind that was the higher error recovery of experienced workers. Therefore, increasing the training provided to new hires could significantly contribute to keeping the schedule pressure manageable if the



Jiao et al. (2022) asserted that establishing system dynamics models is complicated, especially for socio-technical systems, as there is a gap in the formal definition of the qualitative modeling phase. The paper stressed three problems: extracting risk factors and their deterministic relationships, quantifying the causal relationships between the risk factors, quantifying the safety levels, and providing early warning for weaknesses. Researchers addressed these problems by offering to integrate system dynamics and system theoretic process analysis (STPA) methodologies with the help of analytical network process (ANP). The researchers described a methodology in which the STPA is used to explain the static safety control structure of the system, ANP is used to quantify the hierarchy of the elements influencing system safety, and SD is used to model and analyze the dynamic process. Figure 2-14 gives the simplified flow chart of the suggested hybrid framework (Jiao et al., 2022).

The article also included a case study of a coal mine in China using the suggested methodology. In the case study, researchers built the static STPA model based on two system loss conditions: injury/fatality and failure of mining mission. The hierarchical control structure highlighted 22 unsafe control actions (UCAs), and the authors listed possible corresponding causal factors. The ANP methodology further classified those causal factors under four categories. According to the analysis conducted in Super Decision software, the equipment maintenance, physical environment, and department response speed step forward for the given case study as the most significant factors influencing safety. The stock and flow diagram embedded those factor weights in the equations for the dynamic analysis. Ultimately, the case study analysis interpreted that decision-makers should pay closer attention to equipment and environmental safety. Although researchers claimed that integrating the three methodologies is promising, they also argued that the case study results could have been better as the model was based on insufficient publicly available information.

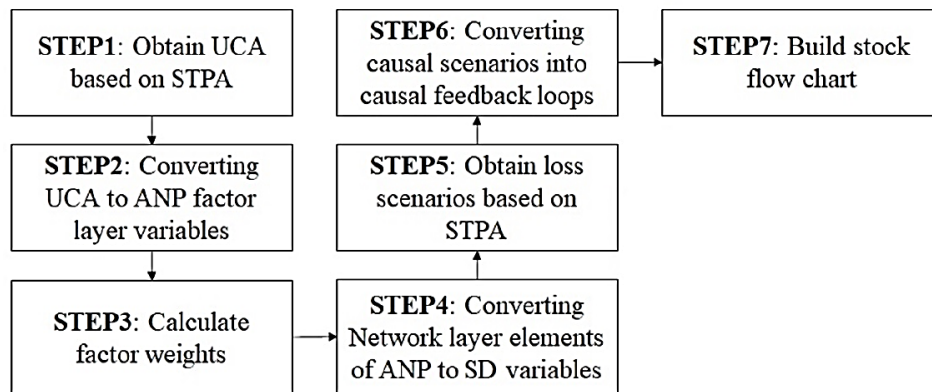

Figure 2-14 Hybrid Framework Process Simplified from Jiao et al. (2022)

Yang et al. (2022) studied another combined methodology that adopts system dynamics in the simulation phase for deep coal mining safety. When building the static model, researchers suggested using the human factors analysis and classification system (HFACS) developed by Wiegmann & Shappell (2001). They used each factor specified in the HFACS framework as an operation variable in the structural equation model (SEM). The study created a Likert-scaled questionnaire for model validation and tested it by using SPSS software. The results formed the basis for factor weights, and the SEM model incorporated these values as standardized path coefficients, as shown in Figure 2-15. For the system dynamics simulation, the paper interpreted the causal relationships in a stock and flow diagram in which the mathematical expressions considered the path coefficients. The simulation for five scenarios in Vensim PLE software in which the safety input allocations differ. The results show the effects of investing on different classes depicted in the HFACS framework. The study attempted to ground its model on the HFACS framework and equations on SEM methodology. However, as the framework limits the variables in the model, the simulation results are depicted in broad categories requiring rigorous interpretation by researchers. It, in turn, limits the practicality of potential use in safety decision-making.

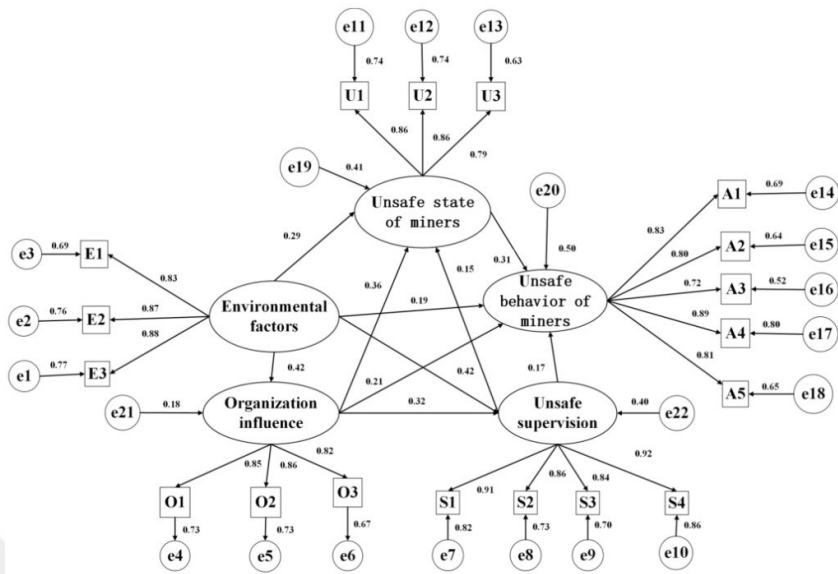

Figure 2-15 The Standardized Structural Equation Model by Yang et al. (2022)

In addition to coal mining applications, SD models have also gained attraction for gold mines where different types of occupational risks are available. Accordingly, Saldarriaga-Isaza et al. (2015) built a behavioral simulation model using Powersim software to understand the social dilemmas in the scope of small-scale gold mining operations. The study addressed the complexity of the socio-ecological system by building a causal loop diagram model based on previous studies on core relationships of collective action.

Verrier et al. (2021) attempted to create a system dynamics-based methodology for supporting gold mining stakeholders' decision-making regarding the environmental, social, and governance risks. The paper is not specifically on health and safety, but the model includes "risk of incidents" and "community health and safety" modules. The authors claimed to combine social, technical, and environmental factors for the first time in a model for gold leaching processes. The study brought the intangible parameter "public trust" into the simulation by creating a user interface in Stella software. The output of the study enables the user to experiment with the long-term effects of different conditions provided by the model.

Selebalo et al. (2021) constructed a system dynamics (SD) model to analyze the potential risk for groundwater exerted by gold mining around a river catchment area in South Africa. They described the state of water resources as a complex system due to determining complex interactions between socio-economic, ecological, and political factors. The model aims to identify interventions that could improve the mitigation of impacts on groundwater to ensure the long-term sustainability of the water supply in the strategic water area. Researchers specified a 40-year interval to simulate the model using the Stella Architect software. Stock and flow diagrams represent the models of subsystems “gold mining & processing,” “wastewater and seepage,” and “neutralizing plant.” The article tabulates the sources of values used for important parameters and test methods used to validate the model. Researchers defined a dimensionless index of “groundwater contamination from mining risk factor” and ran simulations for five scenarios, including the baseline. The results plotted in Figure 2-16 summarize the dynamic risk conditions for the interval, highlighting the importance of a synthetically lined tailings dam.

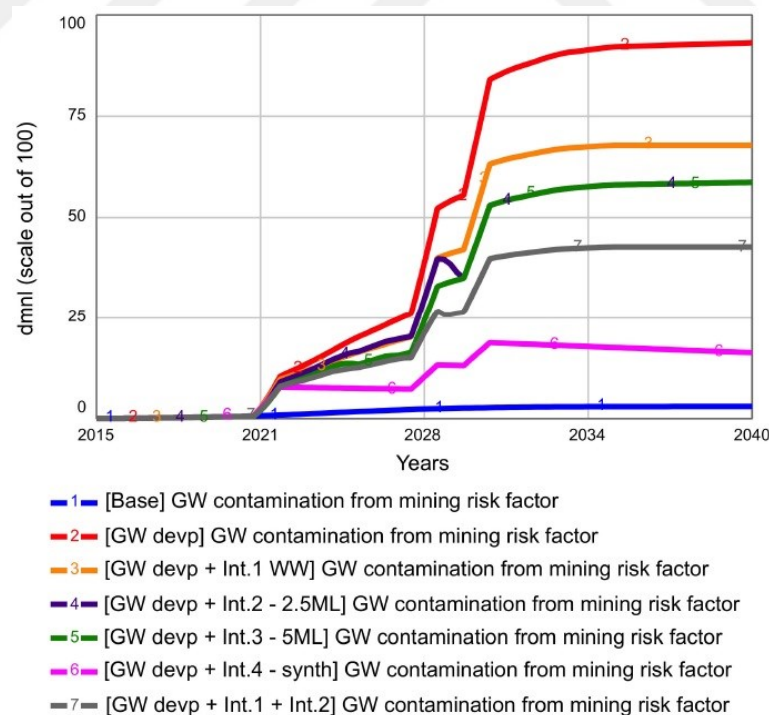

Figure 2-16 A comparative Study by Selebalo et al. (2021)

The literature review also listed plenty of studies that adopt system dynamics models combined with an evolutionary game theory approach to examine coal mine safety regulations, especially in China. Researchers use evolutionary game theory to define a multiplayer game where the players are the decision-makers. They decide on the base assumptions for players' rationale and develop equations accordingly. As the players in the system interact with each other and adjust their decisions based on feedback, system dynamics modeling manifests this dynamic feedback behavior.

In this respect, Liu et al. (2019) performed a combination of evolutionary game analysis and system dynamics in the context of Chinese coal mine safety enforcement. Researchers comparatively discussed the effectiveness of static and dynamic penalty strategies. They developed an SD model for a multiplayer game to analyze players' long-term relationships and dynamic behaviors. The model experimented with various factors to determine effective regulation strategies. Based on the simulation, the authors suggest that simply increasing the fines is ineffective in controlling illegal behaviors. However, choosing a dynamic penalty mechanism can restrain enterprises' legal compliance behavior fluctuations. Static penalty refers to the fines that are pre-defined and fixed; dynamic penalty refers to the fines that depend on the generation numbers of violations/unsafe behaviors or as such. This concept is also applicable to reward strategies.

Yu et al. (2019) focused on the unsafe behaviors of coal mine workers and the inspection regimes of the safety management department. The basic assumption is that both coal miners and safety managers are rational economic persons (*homo economicus*) who behave in line with their cost-benefit analyses. The study divided worker behavior into safe and unsafe; safety management strategies into inspection and no inspection. The equations also considered the errors in decision-making and the rewards and costs of their decisions. Based on the evolutionary game theory approach, the article displays a causal loop diagram incorporating two worker groups' behavior and safety management choices. The simulation run on Vensim software plotted the dynamic evolution of each player's strategy based on the

established model. Findings suggested that although dynamic punishment positively affects workers' behavior, it does not improve safety inspections. However, dynamic incentives can be a factor in motivating safety managers to conduct continuous inspections. The authors included a company's violation metrics in a graphical form that supports the model's findings by showing that the number of violations significantly decreased after applying a dynamic incentive scheme. The assumed causal relationship needs to be clarified as the paper ignored possible underreporting of violations due to the risk secrecy and other possible internal and external influences at the same period for the actual coal mine.

Another study applying system dynamics simulation based on the equations formed using evolutionary game theory was done by You et al. (2020). The article focused on a coal mine enterprise's internal safety inspection system, and once again, it examined the effects of different reward and incentive regimes. The players defined in the game are coal mine employers, safety management departments, and frontline workers. Findings were aligned with the results of Liu et al. (2019) and Yu et al. (2019) regarding the influences of reward and punishment strategies. The article appends that external regulatory forces must act upon the internal game system to ensure high stability and a high ratio of safe behavior. According to the results, the authors assert that the punishment intensity for frontline workers should be lower than for the safety management departments.

Ma et al. (2020) used the combined methodology to analyze the identifiers of conscientious state safety inspection regimes. In the study assumptions, the state inspection behavior moves between execution and dereliction of inspection duties. Equations involved inspection cost, bribery, rewards, expected image loss, coal enterprise penalty, and the state authority's penalty parameters. The study examines the simulation results under three conditions: low inspection cost – low bribery, high inspection cost – high bribery, and intermediate inspection cost – intermediate bribery. Researchers also conducted a sensitivity analysis to specify the importance of parameters in favor of efficient inspection. Not surprisingly, to encourage the state

authority to carry out inspections effectively, the measures to take were reducing bribery, reducing inspection costs, increasing rewards, increasing company discipline, or imposing penalties.

Running simulations for system dynamics models using game theory equations has become a popular topic in Chinese coal mine safety research. However, the studies under this scope involve simplified models with few parameters. Articles mainly examined the reward and incentive schemes -an important topic- although none of those mentioned above models were explicitly grounded on data or an expert group opinion. The models also lack validation. As system dynamics is developed to model complex systems behavior, the system in question should be proved complex first, and model verification efforts should be explicit in the study. Therefore, the research attempted yet hitherto failed that we can reliably analyze the dynamic behavior of a complex system by using game theory equations to establish system dynamics models.

## **2.5 Study Motivation**

The mining sector is characterized by its inherent complexities, involving intricate interactions between various components such as human factors, equipment, environmental conditions, regulations, and organizational structures. Traditional approaches to addressing mine accidents have often focused on reactive measures, overlooking the underlying systemic causes contributing to these incidents.

System dynamics modeling offers a holistic and proactive approach to comprehensively understanding the dynamics and complexities inherent in the mining environment. This methodology aims to construct dynamic models that simulate the intricate interdependencies within mining systems and provide insights into the underlying causal factors contributing to accidents.

The primary objective of this thesis is to employ system dynamics modeling to analyze and comprehend the causal mechanisms leading to mine accidents. The specific goals include:

- i. A comprehensive understanding of the interrelated factors contributing to mine accidents, including human behavior, technical failures, environmental influences, and organizational structures.
- ii. Constructing a system dynamics model that captures the dynamic interactions and feedback loops within the coal mining systems of Türkiye to simulate accident occurrences.
- iii. Analyzing the model to identify critical leverage points and potential interventions that can effectively mitigate and prevent mine accidents.

This research study aims to fill the gap in current accident analysis methodologies by adopting a systems thinking approach for the coal mines in Türkiye. By exploring the systemic causes of mine accidents through system dynamics modeling, this study intends to contribute valuable insights that could aid in developing proactive strategies for accident prevention and fostering a safer working environment within the mining industry.



## CHAPTER 3

### A BACKGROUND DISCUSSION ON THE CAUSES OF MAJOR COAL MINE ACCIDENTS

#### 3.1 Introduction

Coal mine safety can be considered a complex system due to various interrelated factors and dynamic interactions that influence safety within coal mining operations. Several aspects contribute to the complexity of safety in coal mines that can be evaluated considering the multifaceted nature of the operations, the interconnectedness of factors, uncertainties and variability, human factors, and regulatory compliance.

Underground coal mining involves various complicated activities, such as drilling, excavation, material haulage, man transportation, mechanized or self-mechanized operations, ventilation, and monitoring of the mining environment. Each activity brings its own set of risks and safety challenges and holds mutual dependencies on their risk levels. The interactions between diverse elements such as geology, mining equipment, human factors, regulatory compliance, and environmental conditions influence safety in coal mines. Changes in the condition of one event can affect the overall safety of the mining operation.

Uncertainties and variability in coal mine safety are another aspect of the complexity. Geological conditions, the structure of coal seams, subsurface complexities, gas emissions, and geotechnical factors can vary significantly, leading to uncertainties in changeable levels in predicting and managing safety hazards. The involvement of miners, engineers, supervisors, and other personnel introduces complexities related to human behavior, decision-making, training, communication, fatigue, and stress,

all of which impact safety. Coal mining operations are subject to stringent safety regulations and standards that need to be followed. Adhering to and managing compliance with these regulations adds another layer of complexity to safety management.

Considering the root causes of major coal mine accidents experienced in Turkish coal mines and assessing these factors under the group discussed here, a system dynamics model that gained recognition in the literature will be adapted locally for the underground coal mines in Türkiye.

## **3.2 Recursive Behaviors of Major Coal Mine Incidents**

### **3.2.1 The General Problem Definition**

Considering only the coal mine industry of Türkiye, firedamp explosions have remained an unsolved problem for over a hundred years. Even though there have been considerable changes in the socio-technical environment, the recurrence of major coal mine incidents throughout the years is striking. After the catastrophic incidents, legislative changes were experienced, and accordingly, a series of projects, meetings, and workshops were conducted. Even though there is a downward trend of fatalities in the coal mining sector, catastrophic accidents keep coming. The coal mine incidents with the most severe consequences in the last decades are given in Table 3-1.

It is also seen that the Turkish government made a series of policy changes after each catastrophic coal mine incident. The timeline of events regarding the coal mine industry for the period between 2010 and 2020 is given in Figure 3-1 (TMMOB, 2021).

Table 3-1. Major Coal Mine Incidents in Türkiye During the Last Decades

Place	Date	Type of Incident	Death Toll
Sorgun, Yozgat	26.03.1995	Explosion	37
Ermenek, Karaman	22.11.2003	Explosion	10
Gediz, Kütahya	08.09.2005	Explosion	18
Dursunbey, Balıkesir	02.06.2006	Explosion	17
M.Kemalpaşa, Bursa	10.12.2009	Explosion	19
Dursunbey, Balıkesir	23.02.2010	Explosion	13
Karadon, Zonguldak	17.05.2010	Explosion	30
Elbistan, Kahramanmaraş	10.02.2011	Slope Failure	11
Kozlu, Zonguldak	07.01.2013	Methane Outburst	8
Soma, Manisa	13.05.2014	Mine Fire	301
Ermenek, Karaman	28.10.2014	Inundation	18
Şirvan, Siirt	17.11.2016	Slope Failure	16
Amasra, Bartın	14.10.2022	Explosion	41

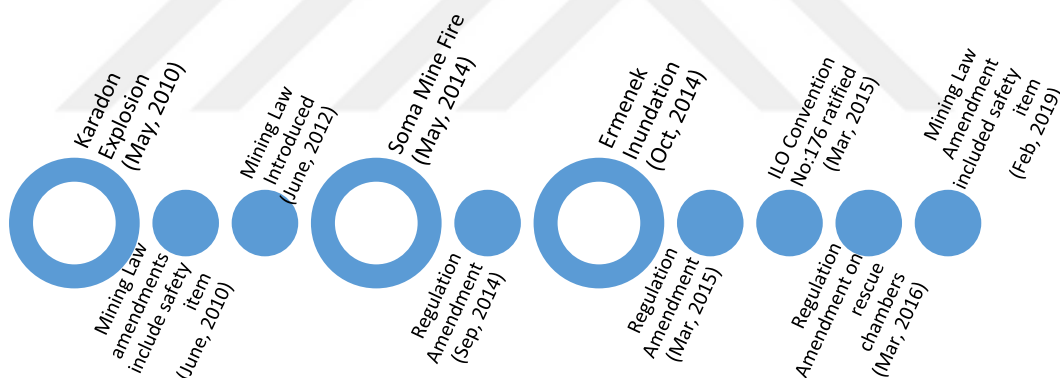

Figure 3-1 Legislation Amendments and Major Coal Mine Incidents Timeline (adapted by TMMOB, 2021)

It is important to note that coal mining operations, mainly underground coal production, are among the most hazardous industrial operations. However, the recurrence in this specific industry is explicitly observed considering all the other high-hazard industries, such as nuclear power plants and refineries.

This study suggests that the recurrence of major unwanted events in the Turkish coal mining industry fits a phenomenon called *drift into failure*, and the mechanisms that generate this drift result from the complex interactions between the system components along the timeline. According to Brady (2019), it is impossible to understand the mining industry's safety without understanding the interactions of safety components with other components, such as production pressures, economic constraints, culture, and unions. Dekker (2011), in his notable book *Drift into Failure: From Hunting Broken Components to Understanding Complex Systems*, states that regardless of how often a company emphasizes its commitment to safety, the actual safety of the workplace will be governed by competing goals. Despite the interventions done with the best intentions, the complex systems can drift back to a higher level of risk acceptance. This study introduces a generic system dynamics model to understand the complex interactions in the Turkish coal mining system.

### **3.2.2 Major Coal Mine Accidents as An Outcome of Dynamic Complexity**

In a coal mining environment, failure to control methane results in disastrous consequences. The methane explosions are categorized as low-frequency but high-impact events. The failure mechanisms involve different parameters of human, environmental, and equipment interactions that are tightly bound together. The interactions change over time due to both internal and external conditions. The changes in the external environmental parameters might seem challenging to foresee, but non-technical parameters might even be more unpredictable. For instance, the technical capacities of employees change due to turnover, and the production requirements affect the safe choices of management and workers.

Methane explosions, therefore, show the properties of a system failure and a result of dynamic complexity. The problem has been well-recognized by all the stakeholders. After each catastrophic failure, the governments make policy changes, the industry leaders gather to analyze the problems, academia and non-governmental

organizations such as professional chambers and international bodies publish reports, and public awareness rapidly increases to alert pressure groups to scrutinize the safety of the coal mining industry. However, public awareness of coal mine safety decreases over time, but mining industry professionals keep putting in the effort for a longer time. Nevertheless, catastrophic accidents keep occurring at more or less the same frequency.

It is observable that despite all the policy changes, investigations, and efforts, catastrophic accidents in the coal mining industry could not be prevented from occurring. Thus, the policy interventions after the past incidents have been almost ineffective. Even though there is a slight downward trend of fatality rates in the industry for the long term, catastrophic occurrences remain available over time. This condition strongly indicates that policy-making efforts should address different leverage points in the system to address system failures effectively.

Boukas and Kontogiannis (2019) summarize the mine accident causation and emphasize that organizations drift outside the safe margins in time. During that drift, the *delays* in the system feedback structure may result in management underestimating the risks as they dynamically change over time. This operational blindness can be overcome by revealing the complex interactions in the system and finding the leverage points. In this study, failure mechanisms for the coal mining industry leading to disastrous consequences were examined by system dynamics modeling. This study handles the problem of the recurrence of systemic failures in coal mines due to dynamic complexities and interactions.

### **3.3 Baseline System Dynamics Models for Coal Mine Accidents**

Even though some other studies concentrate on system dynamics modeling of mine accidents, the models by Cooke (2003) and Boukas and Kontogiannis (2019) are recognized to offer extensive and detailed approaches to evaluating major coal mine incidents. Therefore, these models will be taken as baseline models to comprehend

the nature of dynamic interactions causing major incidents in underground coal mines. Both models are built to explain accident causation in the coal mining industry. Here, the former study focuses on a specific real-case scenario, and the latter concentrates on forming a generic model considering a typical coal mine system. Both models define four subsystems, called safety, production, human resources, and mine capacity and task management subsystems in interaction.

The current study will modify and adapt these two literature models for the Turkish coal mining industry. These four subsystems, common in both models, will be discussed in detail in the following subsections to achieve a proper adaptation.

### **3.3.1 The Safety Subsystem**

Cooke (2003) tried to explain the complex interaction in forming a given real case scenario; the model output was defined as *incident rate*. The incident rate can be considered the outcome determining the system's *safety*, as shown in Figure 3-2. It is the stock where risky behavior, unsafe conditions, and industry incident rates accumulate. All three parameters have a positive correlation with the incident rate.

The unsafe conditions are treated as an outcome of the relative management commitment to safety (rMCS). As MCS increases, the number of unsafe conditions is reduced. The management commitment to safety is modeled as a balancing loop structure where exogenously defined baseline values are influenced by a stock called the change in MCS. It is influenced by the pressure to change MCS. The negative influence on the pressure to increase MCS comes from the production priority over safety, whereas the relative incident rate outcome balances it. Even though the lower values of MCS increase the possibility of having a higher incident rate, the higher incident rates eventually cause an increase in the MCS. However, the production priority over safety is a reinforcing loop that negatively impacts the pressure to change management commitment to safety. In the system overview, it is the link between the production subsystem and the safety subsystem.

The risky behavior of the individuals is shown as the second factor directly related to the incident rate. It is a function of relative personal commitment to safety (rPCS), which is the resultant parameter of a balancing loop where the defined baseline value of PCS is influenced by the pressure to change it. It is linked to the human resources subsystem, and the positive interaction comes from the reinforcing loop of the effect of experience on PCS. That is to say, the experienced workers are expected to have a safety learning exponent. It increases the pressure to change the PCS. Thus, the risky behavior increases only when the rPCS value decreases.

The third factor is the industry incident rate, which serves as a baseline value for the industry. The rationale is that the industry's normality affects the specific mine's tendency to produce incidents. The gap between the incident rate of the system in question and the industry standard influences both MCS and PCS.

In Boukas and Kontogiannis (2019), the outcome of the safety subsystem was defined as the *average risk index*, as seen in Figure 3-3. The average risk index is the addition of accumulated stock of the risk changing in time to the initial risk, as given in Equation 3.1. An initial risk should be defined as a starting point, and the added instantaneous risk is a function of risk potential changing throughout time.

$$\text{Av. Risk Index} = \text{Initial Risk} + \int_0^t \text{Risk index rate} \quad (3.1)$$

The risk potential defined by Boukas and Kontogiannis (2019) is similar to the incident rate introduced by Cooke (2003). It depends on the risky behavior of individuals and unsafe conditions, which is an outcome of the relative management's commitment to safety. Risky behavior is positively related to the risk potential and the impact of undetected errors. This factor was an addition to this latter study, and two factors influenced it. The assumption is that when the task backlog increases, the number of undetected errors increases; when the total worker experience increases, the number of undetected errors decreases. On the other hand, the risky

behavior is a resultant parameter of the balancing loop of PCS. Overall, the PCS is affected by the outcome of the average risk index.

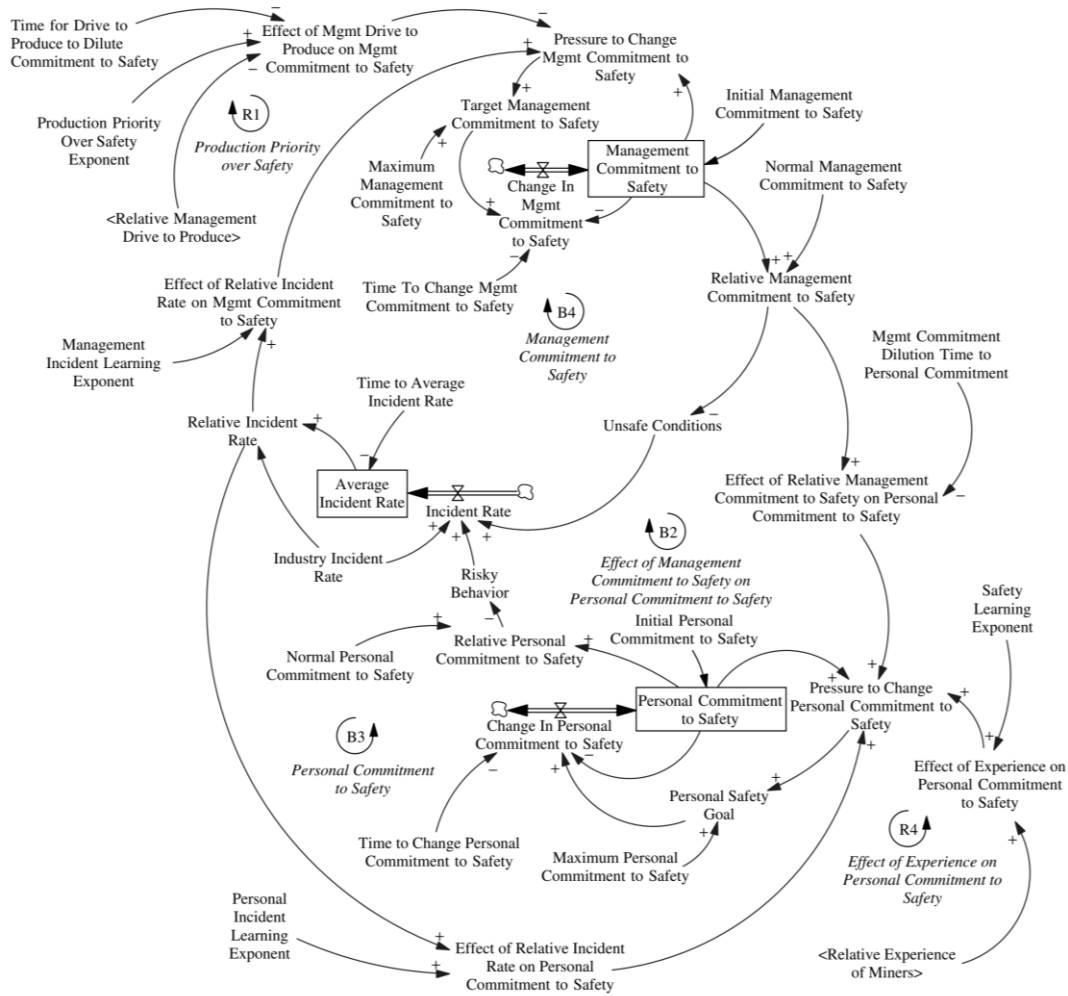

Figure 3-2 Safety Subsystem in Cooke (2003)

Management commitment to safety is another balancing loop structure involving the pressure to change it. Typically, the higher the average risk index, the higher the pressure to change MCS. Also, the increase in MCS sequentially induces a decrease in unsafe condition numbers.

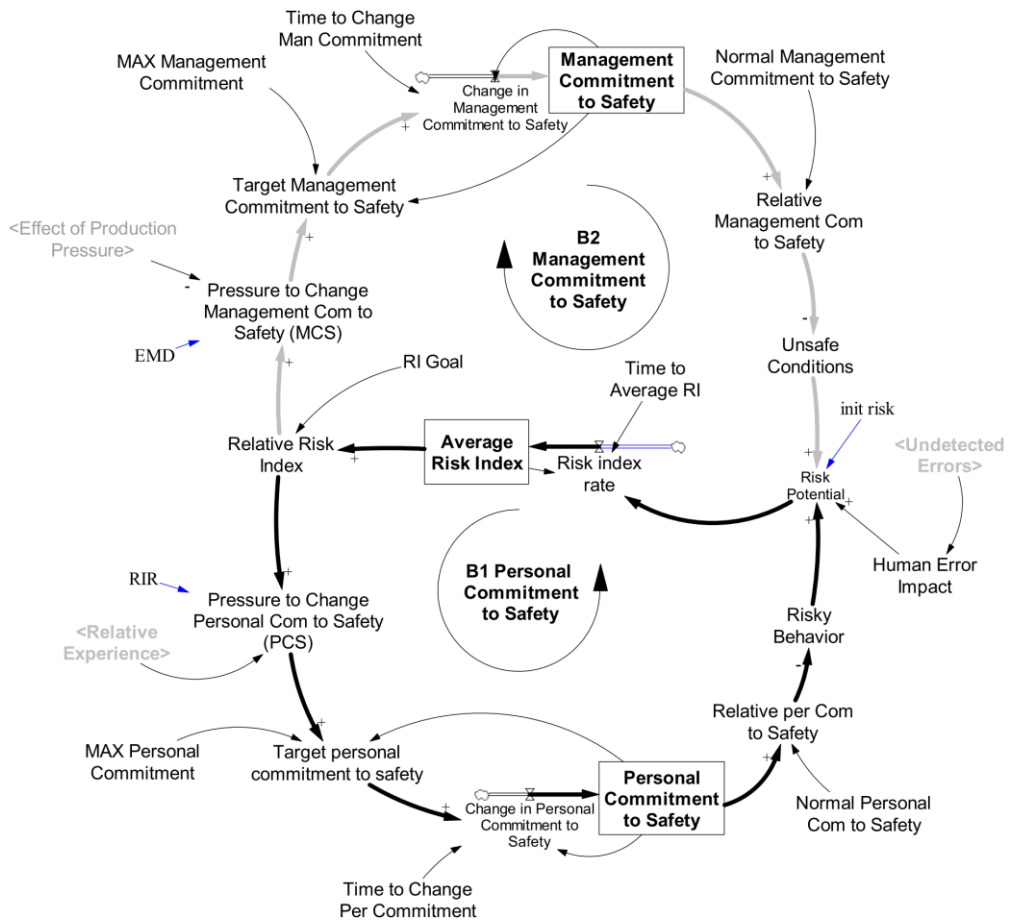

Figure 3-3 Safety Subsystem in Boukas and Kontogiannis (2019)

### 3.3.2 The Production Subsystem

Production is a common subsystem in Cooke's (2003) and Boukas and Kontogiannis (2019). The primary rationale behind the definition of this subsystem is that the production goals of the management are in close relationship with both their commitment to safety and their choices in human resources. High production goals require an increased workforce where the hiring processes affect the instantaneous workforce competency.

Figure 3-4 shows the production subsystem in Cooke (2003). The order backlog parameter was developed in the Westray coal mine explosion context. The subsystem

is defined according to the take or pay contract of the specific mine with the purchaser. The contract specifications limit the production goals, and the order backlog depends on the order rate. The expected order rate drives the management's production rate goal. This condition influences the production rate flow, which is limited by another subsystem called mine capacity. The inflow of production and outflow of shipment determines the stock of inventory. Obviously, an increased order backlog is more likely to occur when the product inventory stock is low. Therefore, the production subsystem defined in the model has specific boundaries exerted by the contract between the producer and the client.

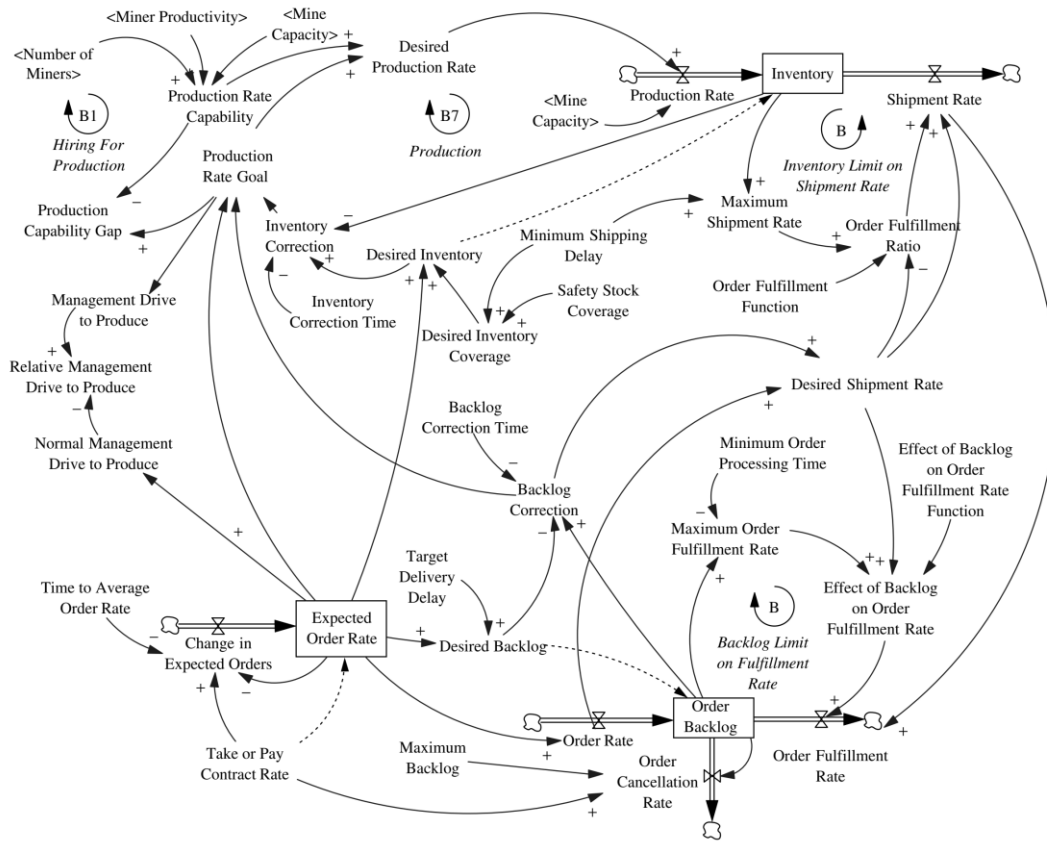

Figure 3-4 The Production Subsystem in Cooke (2003)

Boukas and Kontogiannis (2019) suggested a simplified production subsystem encompassing different coal mine ecosystems (Figure 3-5). The inventory and production rate goals are the primary outcomes of the subsystem. Inventory is limited



diagram. The second balancing loop is the effect of miner experiences on productivity. Miner productivity increases with increasing experience, which inversely influences the hiring rate.

The first reinforcing loop is the effect of incident rate on the loss of experienced miners. The researcher asserts that experienced miners tend to leave the company if the rate of accidents increases. That loss of experience results in lower PCS and higher risky behavior, consequently influencing the incident rate in an unwanted manner. The safer the mine, the more experienced workers are kept by the company. The second positive feedback loop is the effect of MCS on training. In the Westray case, the left miners were generally replaced by inexperienced locals. Their training depends on the relative MCS and the required time to provide the necessary training. The increase in training positively influences the total experience of miners. At this point, it is noteworthy that management commitment to safety is very indirectly influenced by the amount of training provided. The increased experience results in a lower-order backlog as the on-the-job training increases. Therefore, the reduced production rate goal reduces the priority of production over safety. The third reinforcing loop is the effect of experience on the PCS. It is straightforward to assume that the safety experience gained will positively affect the safe decisions of the workforce. Also, the increased personal commitment will help to gain more safety experience.

Overall, the number of miners is in a close relationship with the production subsystem, and therefore, there is an indirect relationship with the safety subsystem. However, the average experience of miners is closely related to both production and safety subsystems.

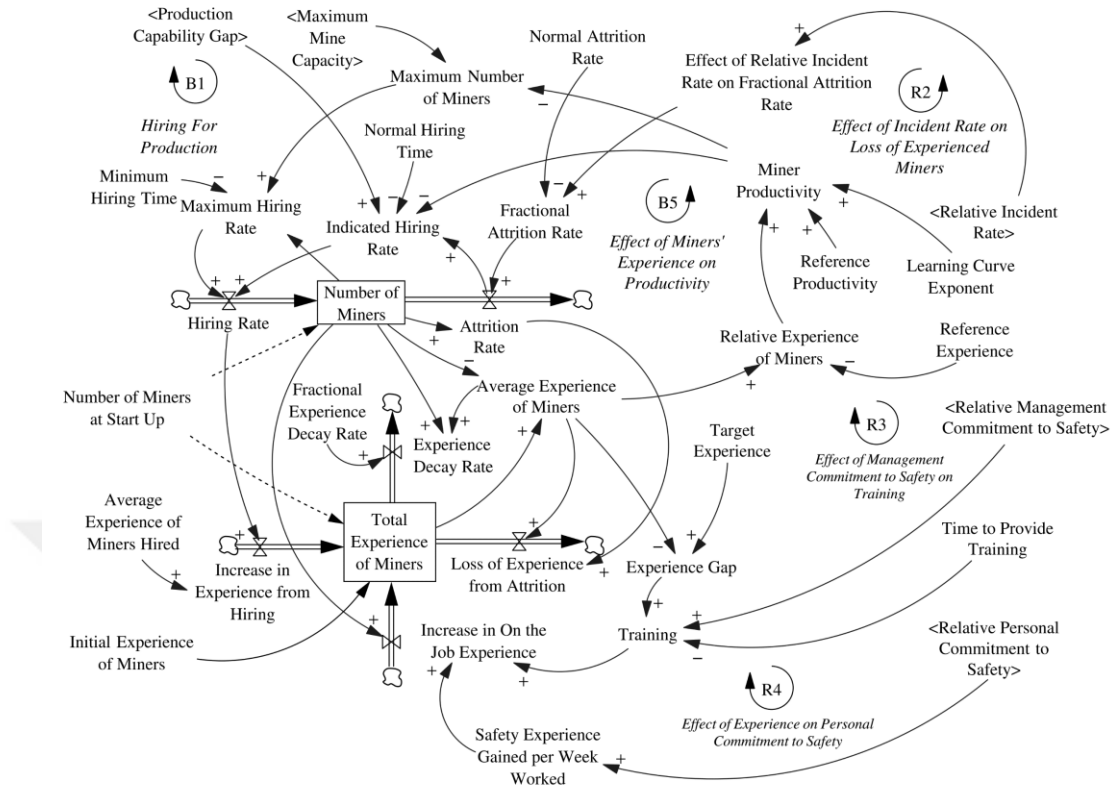

Figure 3-6 The Human Resources Subsystem in Cooke (2003)

Boukas and Kontogiannis (2019) describe the human resource management subsystem as a balancing structure, as seen in Figure 3-7. The stock of the workforce is in an inverse relationship with task schedule pressure, whereas it is in a direct relationship with the production rate. The researchers plotted subsystem diagrams with three balancing loops: hiring loop, workforce and experience loop, and training loop. The hiring rate inevitably balances itself as the workforce accumulation slows down with an increased number of workers. New hires reduce the average experience, and the provision of training depends on the experience gap. The increase in the experience of the workers reduces the experience gap, therefore balancing this loop. Workforce and experience are shown as a balancing loop involving worker productivity, desired workforce, and the average experience.

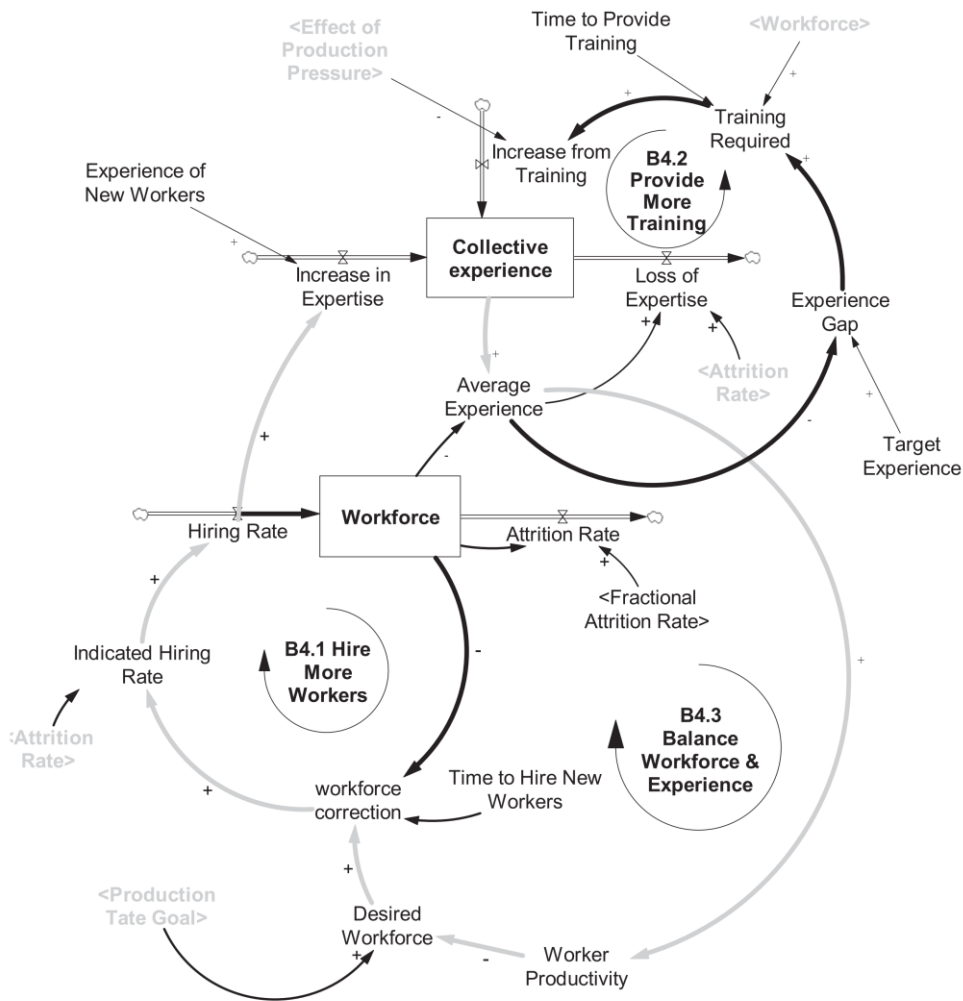

Figure 3-7 The Human Resources Subsystem in Boukas and Kontogiannis (2019)

### 3.3.4 The Mine Capacity and Task Management Subsystems

The mine capacity is a subsystem defined in the Cooke (2003) model, as shown in Figure 3-8. Mine capacity is a stock that accumulates investment, and the outflow is the losses due to the incidents. The model assumes that incident losses are reducing the capacity of the mine, and the capacity of the mine is in a positive relationship with the production rate. So, the losses are indirectly linked with the order backlog, which contributes to the production priority over safety. This part is, therefore,



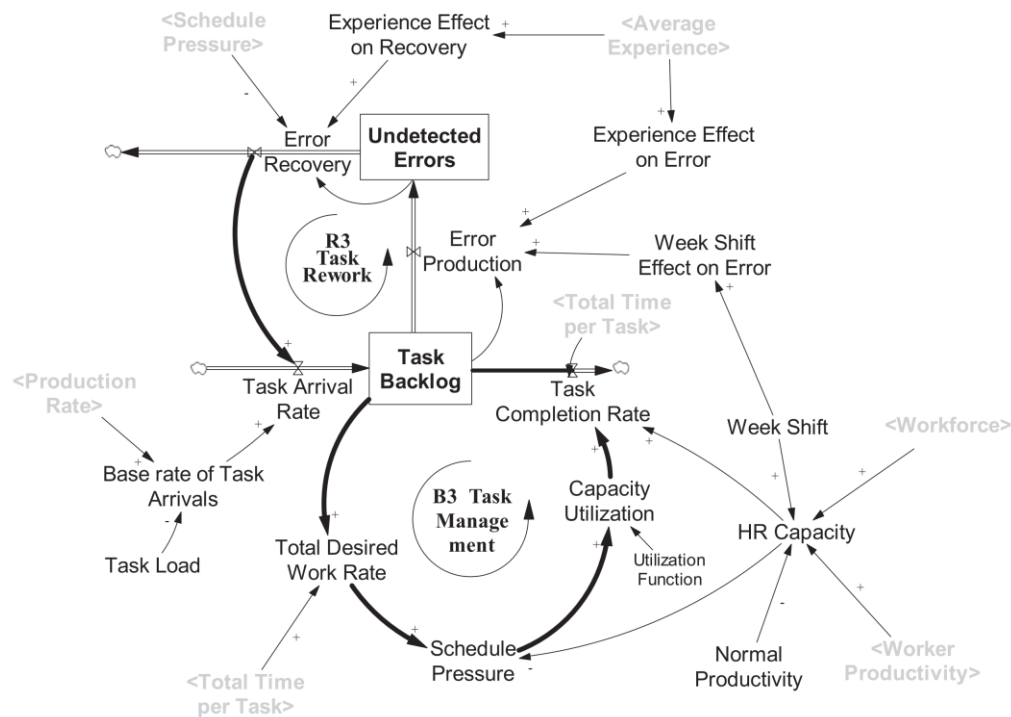

Figure 3-9 The Task Management Subsystem in Boukas and Kontogiannis (2019)

### 3.4 The Complex Nature of the Turkish Coal Mining Industry

This section will intend to explain the particular nature of coal mining conditions in Türkiye that potentially trigger major accidents. Accordingly, two recent catastrophic events in Soma and Amasra will be examined to comprehend the direct and indirect factors leading to these unwanted events.

#### 3.4.1 The Investigations on the Soma Mine Fire

On 13<sup>th</sup> May 2014, a catastrophic incident occurred in an underground coal mine located in the Soma district of Manisa province in Türkiye, and 301 mining workers lost their lives. It was the most severe mining incident in the history of the Republic of Türkiye. A parliamentary committee was immediately established to investigate and prepare a report on the policy changes required to address the underlying causes.

The committee performed inspection visits in Soma and other mining enterprises and listened to workers, company officials, public institutions and organizations, representatives of professional organizations, non-governmental organizations, academicians, and other experts experienced in the subjects of the incident. As a result of the studies, the committee presented the problems of the mining sector and suggested to restructure the policies and impose improvements on the following subjects (TBMM, 2014):

- Safety management efforts inside the workplaces
- Third-party inspections conducted by the state authorities.
- Current mine safety legislation
- Production efficiencies
- The human resource capacities
- Supply chain for technological equipment and services
- Mine rescue services

In the report, problems arising from production pressure and avoidance of investments were emphasized, as well as the problems arising from payroll, supply chain, subcontracting practices, and the lack of quality services.

#### **3.4.1.1 Production Pressure**

The reporters assert that in underground mining operations, production capacity is limited by transportation unit and ventilation system parameters. However, it has been concluded that the production pressure caused by the competition among workers employed in a system based on the principle of working with premiums and even the race between shifts affects the necessary precautions to be taken and causes risky working conditions. This conclusion fits the basic assumption of the baseline models, as the order backlogs are tied to the management's commitment to safety.

In the Soma case, the employer had problems with the equipment supply and even with personal protective equipment. These are indicators that the employer is either making cuts for profit maximization or is having financial difficulty. Financial difficulties or profitability is another factor affecting management's commitment to safety.

The report addresses some specific problems that particularly arise in the Turkish coal mining industry. The royalty applications in Türkiye were considered in the report. When the royalty agreement duration is not long enough to ensure the benefit of their investments in the long term, companies may be reluctant to make technological investments. A clear example is the methane drainage operations that require a high investment cost, but the benefit is a significantly lower explosion risk.

#### **3.4.1.2 Contracting Practices and Production Bonuses**

As suggested by ILO (2016), the contractual conditions also influence the safety of the mines. In Soma and many other coal basins, *gangmasters* are employed to bring workers to the mine. The process of subcontracting a gangmaster workforce is as follows: A gangmaster talks to a coal mine operator and tells him that he has a workforce of generally over 50 people at his disposal that he wants to use for that coal mine. If the employer accepts, one working area will be given only to the employees brought by the gangmaster. Other employees do not enter this part of the mine. However, the employer legally employs all these employees and pays social security premiums as required by law. At the end of each month, the employer pays the gangmaster the sum given in Equation 3.2.

$$(C_m \times P_{\text{agreed}}) - P_{\text{ssp}} \quad (3.2)$$

$C_m$  = Coal mined by the team

$P_{\text{agreed}}$  = Previously agreed unit price of the coal

$P_{\text{ssp}}$  = Social security premium

The gangmaster then distributes this amount to his team based on both the team hierarchy and individual worker performance. Working in small-scale mines can earn higher monthly earnings when working in this type of system. Additionally, a bonus system can be used to earn additional income depending on the production amount and progress. This situation, obviously, is a factor of production pressure and affects personal commitment to safety.

### **3.4.1.3 Human Resource Capacities**

According to TBMM (2014), the workers employed in the mining sector are not provided with sufficient vocational training, and the necessary infrastructure has not been created in this regard. Additionally, ILO (2016) reveals that while the average education period in other sectors increased, the education period of miners in the coal mining sector decreased in Türkiye. At the same time, the average length of work experience in the coal mining sector has decreased compared to other sectors in recent years. Lower education levels and inexperience reduce the capacity to recognize and prevent risk factors in mining. This assertion is compatible with the baseline assumptions that personal commitment to safety increases with higher-quality training.

Another study conducted with the collaboration of the Ministry of Energy and Natural Resources and Hacettepe University examines the vocational trainings and competency requirements in the Turkish mining industry (MAGÜK, 2019). According to the study, the system that regulates employee competencies is closely related to the safety culture throughout the industry.

On the other hand, one of the legal steps taken after the Soma mine fire was to increase workers' wages in underground coal mines to at least twice the minimum wage. The higher labor costs may make management reluctant to hire new employees and provide high-quality training. Therefore, the model should consider that the hiring rate will also depend on the profitability of the mine.

#### **3.4.1.4 The Effect of Internal and External Audits**

After the Soma mine fire, the mitigating effect of safety audits and inspections on the major accident potential of coal mines was discussed publicly, and this issue was also reviewed by TBMM (2014). The report also considers the internal auditing mechanisms of coal mine companies as a part of this auditing mechanism. The importance of the internal auditing mechanism is also emphasized by MAGÜK (2019) as follows: During each mining activity, the mine owner must conduct internal audits either through a system they have established internally or through a method they delegate. Generally, the auditing function should be fulfilled internally, taking the external audits as a final control. Therefore, a mine should undergo systematic internal auditing before being subjected to an official audit, ensuring constant oversight.

#### **3.4.2 The Investigations on the Amasra Coal Mine Explosion**

A firedamp explosion occurred on 14<sup>th</sup> October 2022 in a state-owned coal mine in the Amasra district of Bartın. Unfortunately, the explosion took the lives of 41 workers, and 11 mine workers were injured due to the explosion. A committee under the Turkish Grand National Assembly was established to investigate the catastrophic event and to evaluate the measures to be taken to ensure the safety of the mines. The committee made examinations in the provinces of Bartın and Zonguldak, received information from the authorities, and visited the miners' families in delegations. Some crucial highlights of the committee report are as follows (TBMM, 2023):

- The most important reason for the accident is the presence of methane gas, which creates an explosive atmosphere, and the factors that trigger the explosion could not be managed with these measures.
- The deficiencies in the auxiliary ventilation system were more important than those in the main ventilation.

- Due to the intensity of the coal dust explosion triggered by the methane explosion, the explosion affected most of the mine. Successful dust control was not in place, and water/dust dams were insufficient and mispositioned.
- Blasting activities were not conducted in compliance with the legislation. There was insufficient supervision and control mechanisms to control.
- Due to the lack of personnel at the time of the accident, only one operator was working in the central gas monitoring room, and the central gas monitoring system was not integrated with the audible alarm system, which caused the underground communication network to weaken and disruptions in the flow of information.
- External and internal audits and inspection mechanisms were not effective enough.
- The occupational health and safety training was not sufficient. The inadequacy of putting theoretical training into practice played a role in the widespread impact of the accident.

#### **3.4.2.1 Management Commitment to Safety**

The abovementioned technical factors regarding ventilation and blasting issues are the subjects of the safety subsystem and are related to the management's commitment to safety. When safety was the priority for management, the issues with the auxiliary ventilation could have been solved.

#### **3.4.2.2 Human Resource Capacities**

On the other hand, the problems with the hazard communication in the mine were due to the lack of personnel. The hiring mechanisms under the human resources subsystem are involved in that factor. Likewise, the committee mentioned the

inadequate training of the personnel. It is noticeable that the systemic factors in the disastrous incident are more related to the competency of mid and high-level management rather than the competency of the frontline workers. When the ventilation system or the blasting procedure is in question, the decision-making duty is generally on the mid-level management. The competency of the engineers and foremen is dependent on the management's commitment to safety and employee turnover.

At this stage, the internal audit and inspection mechanisms are also involved. The compliance of the blasting procedures to the legislation (or the company standards) and the adequacy of the auxiliary ventilation are subjected to inspections and audits. The inadequacy of the internal audit systems is another factor linked to the management's commitment to safety. The only external audit mechanism is the inspections done by the government authorities. It is generally an annual visit with short-term improvements and has limited effect on the whole system.

## CHAPTER 4

### DEVELOPMENT OF THE SYSTEM DYNAMICS MODEL FOR MAJOR COAL MINING ACCIDENTS IN TÜRKİYE

When constructing a generic model focused on the major incidents in Turkish underground coal mines, the baseline models by Boukas and Kontogiannis (2019) and Cooke's (2003) model, already discussed in Section 3.3, were utilized.

However, the developed model incorporates local parameters such as the contracting patterns and profitability, which influence the production pressure, and the license time, which influence the investing decisions of the management, which in turn affect the hazardousness and the potential of the mine to produce major incidents such as explosions or mine fires that result in multiple fatalities. Accordingly, the conceptual model was constituted using the baseline models, and some adjustments were made in accordance with the information from the Turkish case scenarios.

#### 4.1.1 Crucial Aspects and Boundary of the Conceptual Model

In addition to safety literature, the modeler's individual assumptions are included to construct a model representative of actual events. On this basis, a basic causal loop diagram was drafted first to depict the fundamental structure of Turkish coal mining in the context of major incident-producing potential. The basic model focuses on the major incident risk index and considers human resources and production via safety phenomena such as production pressure effect on safety and effects of licensing & royalty on long-term investments for mine technology.

### *The Effect of Profitability*

The profitability of a mine is one of the key factors that influence its safety. The dynamism of the profitability of a coal mine is influenced by production rate, fluctuation of coal prices, and expenditures. A common dynamic is a reinforcing loop where increased profitability leads to a desire for higher production rates. Changes in profitability may not immediately translate into changes in production rates due to lags in decision-making, implementation, or market responses. Besides, there are limitations to production growth. Profitability might be constrained both internally by the production capacity of the mine and externally by the market demands.

### *Production Priority over Safety*

One of the underlying assumptions in the model is that, instead of considering accidents as a result of a series of events due to a combination of an unsafe act and unsafe conditions, the model recognizes that unsafe conditions are accumulated stocks that remain unrecognized or unfixed in time. These unsafe conditions give weak signals and time-to-time results in minor safety losses.

The unsafe conditions are considered as results of both human acts (the risky behavior of people) and the inherent hazardousness of the working environment. Safety interventions fix unsafe conditions due to internal or external processes. The employees might discover the minor indicators of a catastrophic event coming and might be overcome by timely interventions. During daily working practice, employees take corrective actions either personally or with the directives of their supervisors. Comprehensibly, a solid drive to produce may lead to reduced emphasis on safety commitment and result in an increased accumulation rate of unsafe conditions. However, minor safety losses or increased complaints from employees put a limit on that growth as they would put pressure on managers, supervisors, and frontline workers. Also, the frequency of external audits and legal inspections influences system safety, even though their effects might have limited longevity.

### *Management's Commitment to Safety*

The coal mine safety system accumulates a disastrous incident potential in time due to unsafe conditions that remain unfixed. Management's commitment to safety is the key to recognizing and intervening in unsafe conditions. A strong commitment leads to increased investment in safety interventions and improving safety conditions. As the context drives behavior, management commitment can strongly influence personal commitment. A high level of personal commitment to safety is expected to reduce risky behaviors among workers. Employees firmly committed to safety are more likely to adhere to safety protocols and minimize risky actions.

A competent and stable management fosters a positive safety culture, influencing employees' personal commitment to safety. When workers observe effective management responses and actions to enhance safety, it reinforces their own commitment to maintaining a safe working environment. A competent management will also be keen to research and utilize technologies that enhance safety and production, which in turn will influence the mine's hazardousness.

### *The Technological Investments*

The Amasra Report (TBMM, 2023) suggests that it is necessary to encourage companies with the economic size and experience to make the necessary and sufficient investments throughout the operating life of a mine. The inadequate and ineffective ventilation system was pointed out as the main factor in the occurrence of the incident. The report mentioned that the investment and research activities regarding methane drainage necessary to reduce the methane content of the pit and make it safer were not carried out.

The suggested conceptual model considers the link between investment attitudes and management capacities. Technological investments that influence the safety of the mine include but are not limited to potential enhancements in the ventilation system, adopting a methane drainage system, operating with highly mechanized production methods, organization of the main headings, and utilizing state-of-the-art gas

monitoring systems. These investments are limited by the license longevity. Due to local legislation, this license lifetime is more important for private companies than for government-owned enterprises.

The management capacity concept was developed to include both the engineering competency and financial resilience of the management, as those factors are influential in determining the will to invest in safe technologies. All the above examples of technological enhancements have high investment costs, with few having short-term visible outcomes. Therefore, the decision-making process in their favor requires competent executives with stable resources. The concept then evolved into encompassing corporate governance.

#### *The Effect of Worker Productivity*

Worker productivity is included in the conceptual model. As workers gain experience, subsequently, their productivity tends to increase. Competent workers with the necessary skills and knowledge will likely be more productive. However, if turnover is high, the collective experience decreases, affecting competency.

Employee turnover is closely related to management capacity. It is known that private coal mining companies use short-term employment of mine workers to reduce labor costs. This condition results in high employee turnover and loss of valuable experience. However, good governance acts as a balancing force in time, reducing turnover and positively influencing worker productivity when the mine is profitable.

#### *The Effect of Training*

Quality training increases the worker's competency and, therefore, personal commitment to safety. Workers committed to safety and possessing the necessary skills are less prone to risky behaviors.

Worker competency, in turn, influences worker productivity. Competent workers are more likely to perform their tasks efficiently and adhere to safety guidelines,

positively impacting overall productivity. The interactions in the model aim to capture the dynamics between the parameters in the context of safety and production.

### The Model Boundary





The boundary selection is a crucial step when constructing an SD model. The amount of detail included in the model could increase the model resolution; however, especially when working with index-based values and qualitative variables, the model validity decreases. Therefore, selecting variables considering their relevance to the aim and scope of the study is a critical step. In the scope of the study, the variables used in the model are classified into three categories. These are endogenous, exogenous, and excluded parameters. These set the boundaries of the model, and the selected variables are listed in Table 4-1. For simulation purposes, the model also uses additional converters to set the equations explained under the relevant subsystem.

Table 4-1 The Boundaries Chart for Turkish Major Coal Mine Incidents Model

<b>Endogenous</b>	<b>Exogenous</b>	<b>Excluded</b>
Coal Production	Coal Market Demand	Human Ill-intention
Corrective/Preventive Actions	Coal Prices	Labor Union Effect
Employee Competency	Corporate Governance	Cost Fluctuations
Employee Hiring Rate	Effect of External Audits	
Employee Leaving Rate	License Deadline	
Employee Productivity	Maximum Mining Capacity	
Employee Satisfaction	Mine Natural Hazardousness	
Employee Training		
Financial Condition		
Investment in Safe Technologies		
Major Incident Index		
Management Capacity		
Management Commitment to Safety		
Management Drive to Produce		
Number of Employees		
Personal Commitment to Safety		
Profitability		
Unsafe Acts (Risky Behavior)		
Unsafe Conditions		



Table 4-2. The Building Blocks of a Stock-and-Flow Model

Building Block	Name	Explanation
	Reservoir	The type of stock that passively accumulates its inflows minus any outflows.
	Module	Subsystems that are connectible to other subsystems.
	Converter	The main building blocks that convert inputs into outputs. It can hold constant value, define external inputs, and calculate equations or graphical functions.
	Flow	Flows fill and drain stocks. The flows can be in one direction or bi-directional.
	Connector	The element that connects variables to each other. Connectors indicate an immediate effect.

### 4.1.3 The Safety Subsystem

The safety subsystem consists of the components directly related to safety in the system. The assumption behind the model is that accumulated unsafe conditions lay the foundation for a potential major incident along with the natural conditions of the mine. According to the model, risky behavior is a natural outcome of normal operational deviations, and these human acts are the sources of unsafe conditions piling up over time. The accumulation rate depends on the volume of the mining activity and the natural conditions. In that sense, an increase in production will increase the rate of unsafe condition accumulation. Meanwhile, these unsafe conditions created by normal work activities are recognized and fixed at a certain rate. The study divides these interventions into three categories: Personal interventions during normal work, management interventions due to internal risk management strategies, and discrete packs of interventions upon external audits. The overall view of the stock-and-flow diagram of the safety subsystem and expressions of the diagram parameters are shown in Figure 4-2 and Table 4-3, respectively.

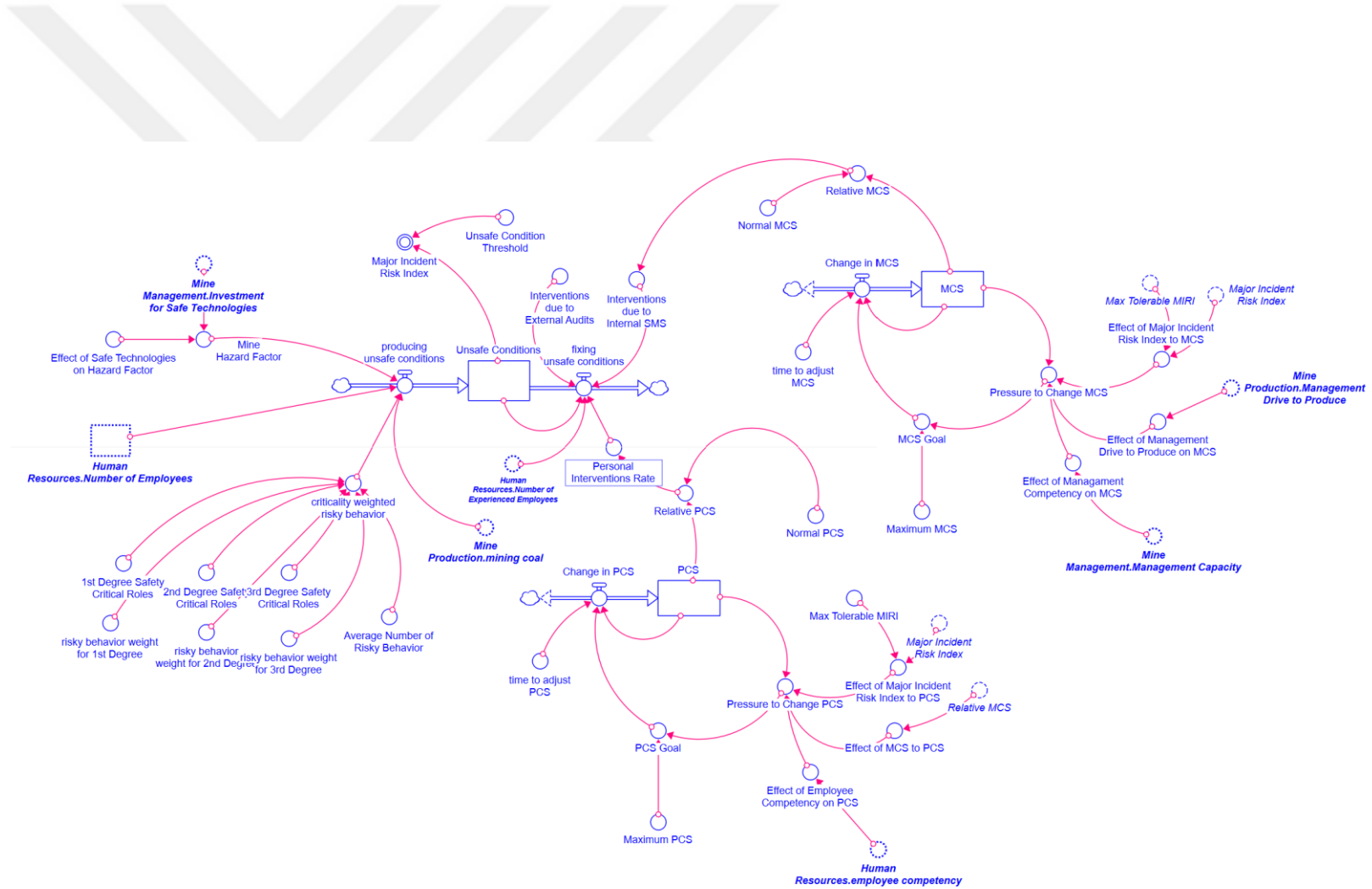

Figure 4-2 Stock-and-Flow Diagram of the Safety Subsystem

Table 4-3 Diagram Parameters and Variables of the Safety Subsystem

Name	Type	Variable explanation	Equation	Units
MCS(t)	Stock	Management commitment to safety	$MCS(t-dt) + (\text{Change in MCS}) * dt$	Percent
PCS(t)	Stock	Personal commitment to safety	$PCS(t-dt) + (\text{Change in PCS}) * dt$	Percent
Unsafe Conditions(t)	Stock	Momentary amount of accumulated unsafe conditions.	$\text{Unsafe Conditions}(t-dt) + (\text{producing unsafe conditions} - \text{fixing unsafe conditions}) * dt$	Number
Change in MCS	Flow Regulator	The rate of change in MCS	$(\text{MCS Goal} - \text{MCS}) / \text{time to adjust MCS}$	Percent/Months
Change in PCS	Flow Regulator	The rate of change in PCS	$(\text{PCS Goal} - \text{PCS}) / \text{time to adjust PCS}$	Percent/Months
Fixing unsafe conditions	Flow Regulator	The rate of corrective actions	$(\text{Number of Experienced Employees} * \text{Personal Interventions Rate}) + (\text{Interventions due to Internal SMS} * \text{Unsafe Conditions}) + (\text{Interventions due to External Audits} * \text{Unsafe Conditions})$	Number/Month
Producing unsafe conditions	Flow Regulator	The rate of production of unsafe conditions	$\text{IF } (\text{Mine\_Production.mining\_coal}=0) \text{ THEN } (0) \text{ ELSE } (\text{Number\_of\_Employees} * \text{criticality weighted risky behavior} * \text{Mine Hazard Factor})$	Number/Month

Table 4-3 Diagram Parameters and Variables of the Safety Subsystem (cont'd)

Name	Type	Variable explanation	Equation	Units
1 <sup>st</sup> degree safety critical roles	Convertor	The ratio of the employees working in most safety critical roles such as mine control room operators, ventilation technicians, blasting operators. [0,1]	User Defined Constant Value	Dimensionless
2nd degree safety critical roles	Convertor	The ratio of the employees working in roles in underground working areas but less safety critical roles such as maintenance workers, transportation workers.	User Defined Constant Value	Dimensionless
3rd degree safety critical roles	Convertor	The ratio of the employees working in roles which is less related to the safety of underground coal.	User Defined Constant Value	Dimensionless
Average number of risky behavior	Convertor	A typical number of risky behavior per employee	User Defined Constant Value	(Number/Month)/People
Critically Weighted Risky behavior	Convertor	The number of risky behavior weighted with the criticality of employee roles in the workplace	Average number of risky behavior * (1 <sup>st</sup> degree safety critical roles * risky behavior weight for 1 <sup>st</sup> degree) + (2nd degree safety critical roles * risky behavior weight for 2nd degree) + (3rd degree safety critical roles * risky behavior weight for 3 <sup>rd</sup> degree)	(Number/Month)/People
Effect of Employee Competency on PCS	Convertor	The competency of employee index number [0,1].	IF((employee competency / 100) >=1) THEN (1) ELSE (employee competency/100)	Dimensionless

Table 4-3 Diagram Parameters and Variables of the Safety Subsystem (cont'd)

Name	Type	Variable explanation	Equation	Units
Effect of Major Incident Risk Index to MCS	Convertor	MCS is influenced by the ratio of MIRI to the maximum MIRI [0,1].	IF (Major Incident Risk Index >= Max Tolerable MIRI) THEN (1) ELSE (Major Incident Risk Index /Max Tolerable MIRI)	Dimensionless
Effect of Major Incident Risk Index to PCS	Convertor	PCS is influenced by the ratio of MIRI to the maximum MIRI [0,1].	IF(Major Incident Risk Index >= Max Tolerable MIRI ) THEN (1) ELSE (Major Incident Risk Index / Max Tolerable MIRI )	Dimensionless
Effect of Management Competency on MCS	Convertor	Percent index of management competency	Management Capacity	Percent
Effect of Management Drive to Produce on MCS	Convertor	Management drive to produce [0,1]	1 - Management Drive to Produce	Dimensionless
Effect of MCS to PCS	Convertor	Managements leadership effect on the personal commitment to safety [0,1].	IF(Relative MCS >= 1) THEN (1) ELSE (Relative MCS)	Dimensionless
Effect of Safe Technologies on Hazard Factor	Convertor	The reduction factor of introduced safe technologies on the mine hazard factor	User Defined Constant	Dimensionless
Interventions due to External Audits	Convertor	The effect of external audits. Assumedly a particular percent of the unsafe conditions is removed during each inspection. First inspecion is on n <sup>th</sup> month and frequency is m month.	PULSE (Percent, n month, m month)	Number/Month

Table 4-3 Diagram Parameters and Variables of the Safety Subsystem (cont'd)

Name	Type	Variable explanation	Equation	Units
Interventions due to Internal SMS	Convertor	Management safety interventions. The fraction of corrected unsafe conditions depends on the quality of internal processes. It starts from 1st month and frequency is once a year.	IF(Relative MCS>90) THEN PULSE(0.6, 1, 6) ELSE IF(Relative MCS>50) THEN PULSE(0.5, 1, 12) ELSE PULSE (0.4, 1, 12)	Number/Month
Major Incident Risk Index (MIRI)	Convertor	A suggested final outcome of the whole system. It represents the momentary potential of disaster producing. [0,1].	Unsafe Conditions / User-defined constant value	Dimensionless
Maximum Tolerable MIRI	Convertor	Maximum number of unsafe conditions for a typical coal mine [0,1].	User-defined constant value	Dimensionless
Maximum MCS	Convertor	Maximum value for MCS [0,100]	User-defined constant value	Percent
Maximum PCS	Convertor	Maximum value for PCS [0,100]	User-defined constant value	Percent
MCS Goal	Convertor	The target MCS value due to pressure to change it.	MIN (Maximum MCS, Pressure to Change MCS)	Percent
Mine Hazard Factor	Convertor	The disaster potential of the mine due to natural/geological conditions. [0,1]. 1= Non-favorable conditions; 0= Favorable conditions	User-defined constant value	Dimensionless
Normal MCS	Convertor	A typical value for MCS [0,100]	User-defined constant value	Percent
Normal PCS	Convertor	A typical value for PCS [0,100]	User-defined constant value	Percent
PCS Goal	Convertor	The target PCS value due to pressure to change.	MIN(Maximum PCS, Pressure to Change PCS)	Percent
Personal Interventions Rate	Convertor	Conversion of PCS into monthly risky behavior.	Relative PCS/100	(Number/Month)/People

Table 4-3 Diagram Parameters and Variables of the Safety Subsystem (cont'd)

Name	Type	Variable explanation	Equation	Units
Pressure to Change MCS	Convertor	The pressure to change the MCS	IF (Effect of MIRI to MCS >= 0.8) THEN 100 ELSE (((1.1 *Effect of Management Competency on MCS + 1.1* Effect of MIRI to MCS)/2.2) + (Effect of Management Drive to Produce on MCS)*MCS)	Percent
Pressure to Change PCS	Convertor	The pressure to change the PCS	IF (Effect of MIRI to PCS >= 0.8) THEN 100 ELSE (PCS* (1* Effect of MCS to PCS + 1.25 *Effect of Employee Competency on PCS + 1.75* Effect of MIRI to PCS)/4)	Percent
Relative MCS	Convertor	The MCS value compared to the normal	(MCS/Normal MCS)*100	Percent
Relative PCS	Convertor	The PCS value compared to the normal	(PCS/Normal PCS)*100	Percent
Risky behavior weight for 1 <sup>st</sup> degree	Convertor	The weight of a risky behavior by 1 <sup>st</sup> degree safety critical role in creating a major incident risk	User-defined constant value	Dimensionless
Risky behavior weight for 2 <sup>nd</sup> degree	Convertor	The weight of a risky behavior by 2 <sup>nd</sup> degree safety critical role in creating a major incident risk	User-defined constant value	Dimensionless
Risky behavior weight for 3 <sup>rd</sup> degree	Convertor	The weight of a risky behavior by 3 <sup>rd</sup> degree safety critical role in creating a major incident risk	User-defined constant value	Dimensionless
Time to adjust MCS	Convertor	The delay factor for adjusting MCS	User-defined constant value	Month
Time to adjust PCS	Convertor	The delay factor for adjusting PCS	User-defined constant value	Month

### 4.1.3.1 Management Commitment to Safety

The management commitment to safety is the importance given to safety by the managers. The model assumes that the effectiveness of a safety management system heavily depends on the management’s attitude towards safety, which is demonstrated by the relative commitment of management to the safety variable.

The model suggests that the more commitment, the more effective safety interventions will be done by the management. These interventions are made through internal assurance processes, including formal management audits or more casual management walkabouts. The management commitment to safety is adapted from Cooke’s (2003) Westray model. In that model, management commitment to safety is a capacity-limited stock in percentages. Different variables dynamically act on the pressure to change it. It is notable that the pressure on the management to be more focused on safety is dependent on other dynamic variables such as management drive to produce, management capacity, and major incident index. Figure 4-3 shows the loop for management commitment to safety.

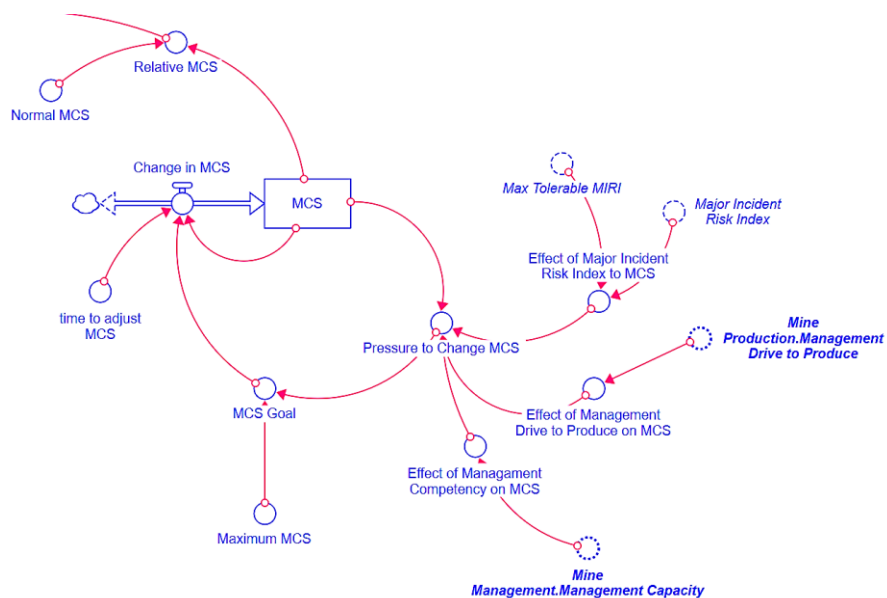

Figure 4-3 Management Commitment to Safety (MCS) Stock-And-Flow Loop

#### **4.1.3.2 Personal Commitment to Safety**

The fixing acts of daily working routine are characterized by a personal intervention rate that depends on the personal attitude towards safety. Regardless of their comprehensiveness, these corrective actions are a part of the daily working routine and are completed by frontline workers upon their will or their immediate supervisor's direction. The assumption is that the higher the personal commitment to safety is relative to a normal personal commitment to safety, the higher the rate of personal interventions to be experienced. When depleting the stock of unsafe conditions, the personal interventions are influenced by the experience of the employees.

Like management commitment to the safety loop, personal commitment to the safety loop is designed by adapting from Cooke (2003) with a slightly different theoretical basis. The pressure on the personal commitment to increase is exerted by several factors, such as the major incident index, relative management commitment to safety, and employee competency, as shown in Figure 4-4.

#### **4.1.3.3 Effect of External Audits and Government Inspections**

External interventions also deplete the stock of unsafe conditions. The most common process that removes unsafe conditions is government inspections. Inspections are completed on a frequency basis and focus directly on the unsafe conditions to remove them for a short period. For every inspection, a portion of the stocked unsafe conditions are removed, and it is assumed that the effects will be one-off for each inspection activity.

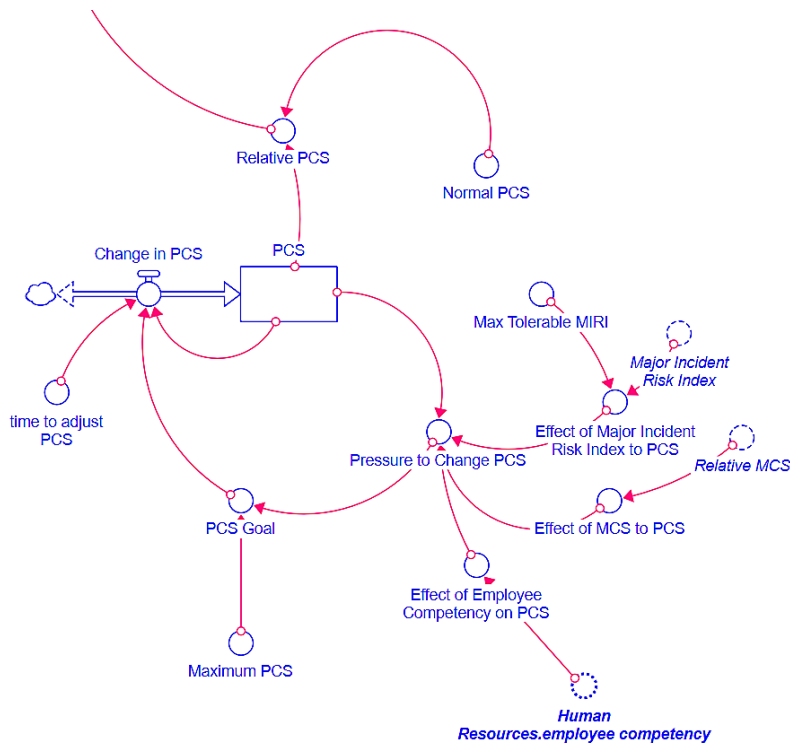

Figure 4-4 Personal Commitment to Safety (PCS) Diagram

#### 4.1.3.4 Major Incident Risk Index

All unsafe conditions are assumed to result from human acts, and the natural conditions influence the riskiness of those unsafe conditions. However, human acts are not solely detrimental to workplace safety. Fixing safe acts is also a normal part of daily routine in a workplace. Stocking of the difference between positive and negative effects is the main influence on the incident potential of the mine.

The outcome of the safety subsystem is an index created to show the potential for a major incident. The major incident risk index is a function of unsafe conditions at a given time to produce an explosion or a mine fire.

### *Mine Hazard Factor*

Mine hazard factor is a discrete function assumed as a constant coefficient influencing the rate of risky behavior. The main idea is that some acts are riskier, depending on the natural conditions of the mine, such as methane release rate or proneness of the coal seam to spontaneous combustion. This value is a real number and theoretically can vary between 0 and 1, with 1 being the most unfavorable condition for an underground coal mine. However, this value is not expected to be close to zero as at least one hazard condition is present in an underground coal mine.

Even though the mine hazard factor is constant for a given mine, the accumulated unsafe conditions will be dynamic; therefore, the major incident risk index is also dynamic. Additionally, the investments in safe technologies during the mine life make a reduction in the mine hazard factor. For example, adopting a better monitoring system reduces the criticality of risky behavior in producing a potential major coal mine accident. This reduction effect is limited and taken as a constant in the model.

### *Risky Behavior and Unsafe Conditions*

The model suggests that unsafe conditions are accumulated by the risky behavior of humans, whereas their criticality is dependent on the natural riskiness of the mine environment. These risky behaviors are also classified according to the role of the employees. This assumption is based on the fact that the consequences of a risky behavior in operating safety critical equipment will not be the same as the consequences of a risky behavior in more neutral roles. In that sense, ventilation operators, blasting workers, gas monitoring, and control room operators can be assumed to have critical first-degree safety roles, and their risky behaviors will lead to a higher accumulation of unsafe conditions considering their population in the total employees and the transition weight between risky behavior and unsafe condition. Transition weight determines the physical reflectance of risky behaviors in unsafe conditions and is the highest for the first-degree safety-critical group.

#### **4.1.3.5 Excluded Parameters and Safety Culture**

The constructed subsystem in the study incorporates exogenous variables such as external audits, mine hazard factors, and endogenous variables that relate to each other via equations. In addition, some parameters are also excluded from the model. The study excludes the effect of labor unions on safety, as the unions are present in a limited number of mines, and the influence of the unions on the organization requires a rigorous effort, which is out of the scope of this study. The study also assumes that the system works on the rational decisions of human beings, and ill-intentioned human actions are not included in the model.

It is notable that the study does not incorporate safety culture as a variable in the system. As a part of the organizational culture, the safety culture is referred to as an overarching concept. In recent practice, efforts have been made to quantify safety culture through surveys. These surveys focus on different dimensions, such as management and personal commitments to safety, priority of production over safety, and several elements of safety management systems typical for mining activities. However, in the constructed model, these dimensions are directly or indirectly mentioned in different variables throughout the system. In other words, acting indicators of the safety culture are included in the variables of the inflows and outflows of unsafe conditions stock. No separate variable is used for safety culture.

#### **4.1.4 The Production Subsystem**

The production subsystem consists of the variables that relate to coal production. The constructed subsystem aims to model the safety-related outcomes of the coal mining production processes. Production processes influence the safety subsystem, affecting employees' competency and management drive to produce more coal. The overall stock-and-flow model of the production subsystem and the expression of related parameters are given in Figure 4-5 and Table 4-4, respectively.

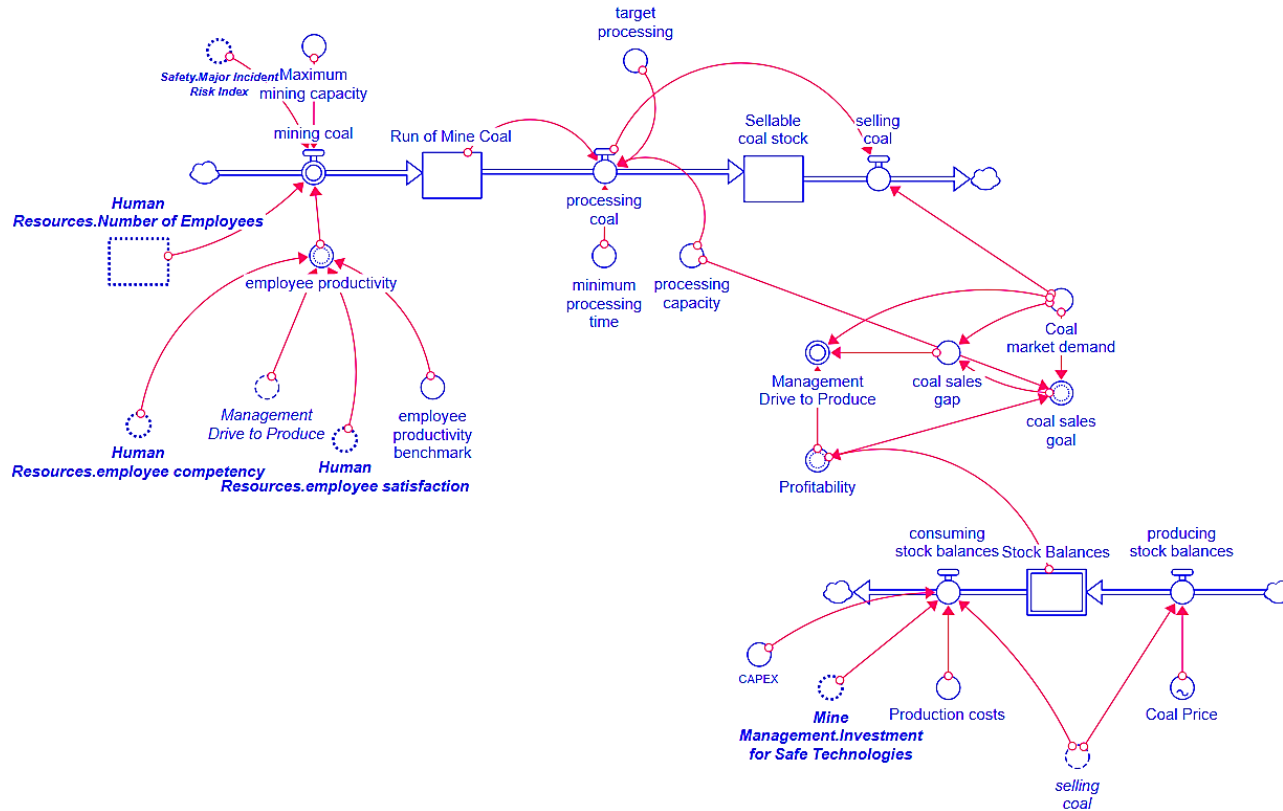

Figure 4-5 Stock-and-Flow Diagram of The Production Subsystem

Table 4-4 Diagram Parameters and Variables of the Production Subsystem

Name	Type	Variable explanation	Equation	Units
Run Of Mine Coal(T)	Stock	Run of mined coal stock in tonnes	Run of Mine Coal(t - dt) + (mining coal - processing coal) * dt	tonnes
Sellable Coal Stock(T)	Stock	Sellable coal stock in tonnes	Sellable coal stock(t - dt) + (processing coal - selling coal) * dt	tonnes
Stock Balances(T)	Stock	The stock of financial balances in dollars	Stock Balances(t - dt) + (producing stock balances - consuming stock balances) * dt	\$
Consuming Stock Balances	Flow Regulator	The rate of spent money due to production costs and occasional investments	(Production_costs*selling_coal)+Mine_Management.Investment_for_Safe_Technologies+CAPEX	Dollars / Month
Mining Coal	Flow Regulator	The extraction rate of run of mined coal. Production ceases when MIRI reaches a certain level m. m is a user defined constant [0,1]	IF (Major Incident Risk Index > m) THEN (0) ELSE MIN((Human Resources.Number of Employees* employee productivity), Maximum mining capacity)	tonnes/Month
Processing Coal	Flow Regulator	The processing rate of coal	MIN(MIN(processing capacity, target processing), Run of Mine Coal / minimum processing time)	tonnes/Month
Producing Stock Balances	Flow Regulator	Income from coal sales	selling coal * Coal Price	\$/Month
Selling Coal	Flow Regulator	Coal sales	MIN(Coal market demand, processing coal)	tonnes/Month
CAPEX	Convertor	Capex to renew equipment on a frequent basis	PULSE(a, b, c)	
Coal Market Demand	Convertor	The assumed coal demand of market	User-defined constant value	tonne Per Month
Coal Price	Convertor	This is the actual sellable price of coal per tonne. 10 years of coal price data is used and stretched to 20 years.	GRAPH(TIME) Points: (0.0, 121.7), (6.0, 121.7), (16.0, 129.6), (23.0, 113.6), (35.0, 96.1), (55.0, 84.4), (67.0, 81.9), (79.0, 63.7), (91.0, 66.6), (102.0, 102.5), (115.0, 86.5), (120.0, 82.6)	\$/tonne

Table 4-4 Diagram Parameters and Variables of the Production Subsystem (cont'd)

Name	Type	Variable explanation	Equation	Units
Coal Sales Gap	Convertor	The gap between the target and actual sales	coal sales goal - Coal market demand	tonnes/month
Coal Sales Goal	Convertor	The target coal sales per month	IF (Profitability<=0) THEN Coal market demand ELSE (processing capacity)	tonnes/month
Employee Productivity	Convertor	The productivity of a coal mine worker due to satisfaction, management drive to produce and competency.	employee productivity benchmark* MIN (1.5 , (MAX (0.6 , Management Drive to Produce * (Employee satisfaction/100) * (employee competency/100)	(tonnes/Month)/ People
Employee Productivity Benchmark	Convertor	A normal productivity value selected for a typical underground coal mine.	User-defined constant value	(tonnes/Month)/ People
Management Drive To Produce	Convertor	Managements production apetite algorithm	MIN (1.5, MAX (1, MAX(Profitability, (1+ (coal sales gap / Coal market demand))))	Dimensionless
Maximum Mining Capacity	Convertor	A capacity limit for a typical coal mine	User-defined constant value	tonnes/Month
Minimum Processing Time	Convertor	The processing time delay factor constant	User-defined constant value	Months
Processing Capacity	Convertor	The capacity limit for processing coal	User-defined constant value	tonnes/Month
Production Costs	Convertor	A cost of production selected for a typical mine.	User-defined constant value	\$/Tonne
Profitability	Convertor	A dimensionless factor of profitability.	Stock_Balances/ PREVIOUS (Stock_Balances)	Dimensionless
Target Processing	Convertor	A selected target value for processing coal	User-defined constant value	tonnes/Month

A typical coal mining activity is a capacity-limited flow of stocked material based on productivity. It means that the production rate depends on the number of workers and their productivity; however, it is limited by the maximum mining capacity of the mine. Figure 4-6 shows that coal is mined at a dynamic production rate and stocked as a run of mined coal. This stock is depleted by processing first and then the coal sales. Management decisions can increase capacity; however, this effect is out of the scope of the study.

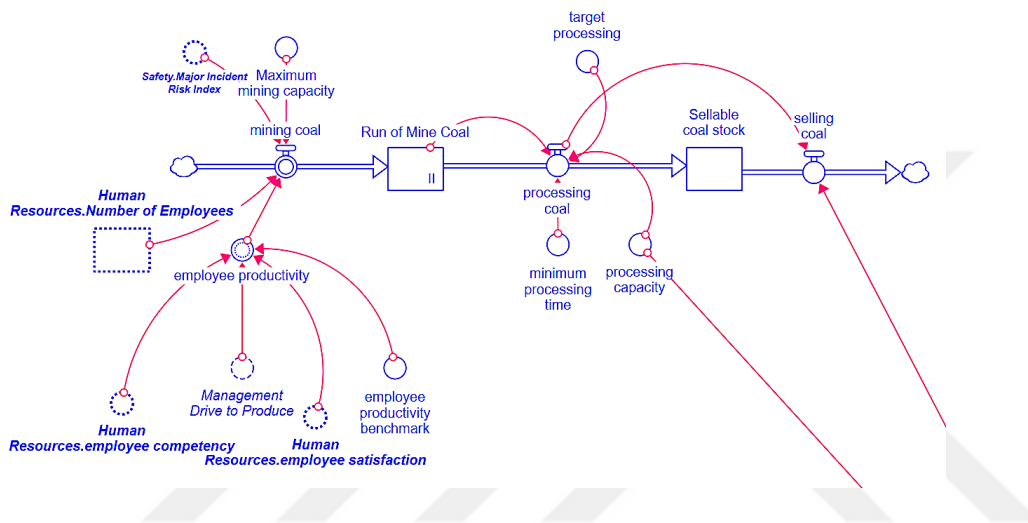

Figure 4-6 Coal Mine Production Flow

The productivity of the employees depends on several factors. These factors are chosen as employee competency, management drive to produce, and employee satisfaction, and these constructed indexes are normalized with a productivity benchmark. The coal mining process finishes with the coal sales and connects to the profitability section of the model. Coal sales are a closing gap type of system dependent upon the coal market demand, which is a determinant of the goal of coal sales. It influences the management’s drive to produce and the profitability component. The financial section of the production subsystem is given in Figure 4-7.

The profitability of the mine is a function of financial balances. When the profitability increases in the developed production system, the mine management is willing to produce more. The income of the mine is heavily dependent on the coal prices that fluctuate over time and production costs that are expected to change over

time. However, production cost fluctuations are excluded from the model and taken as a constant exogenous parameter. Managerial decisions on investing in safe technologies are also considered in the model. Safe technologies can be considered as new purchases of items or services and renovations due to safety concerns, and they deplete the stock balances upon every investment decision. The model excludes these new investments' operational costs and takes that as a one-off payment. Capital expenditures are incorporated as periodical expenditures during the mine life.

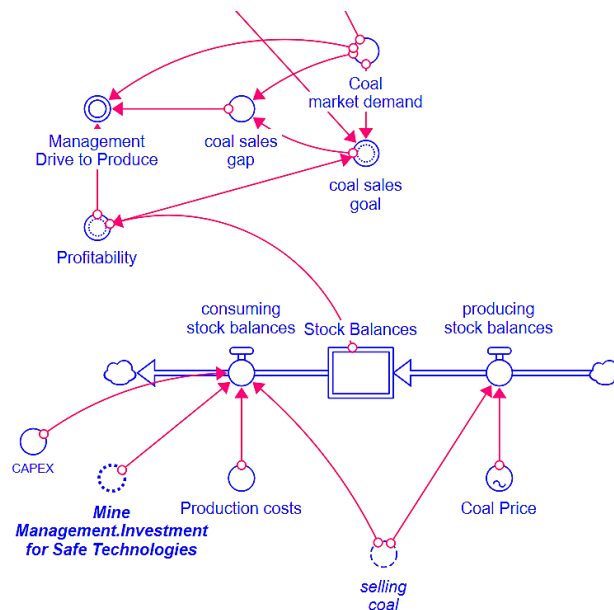

Figure 4-7 Financial section of the production subsystem

#### 4.1.5 The Human Resources Subsystem

The human resources subsystem aims to evaluate the parameters related to human resources that influence the system's safety variables. The human resources subsystem incorporates employees' hiring system, work satisfaction, and competency conditions. The overall stock-and-flow model of the human resources subsystem and the expression of related parameters are given in Figure 4-8 and Table 4-5, respectively.

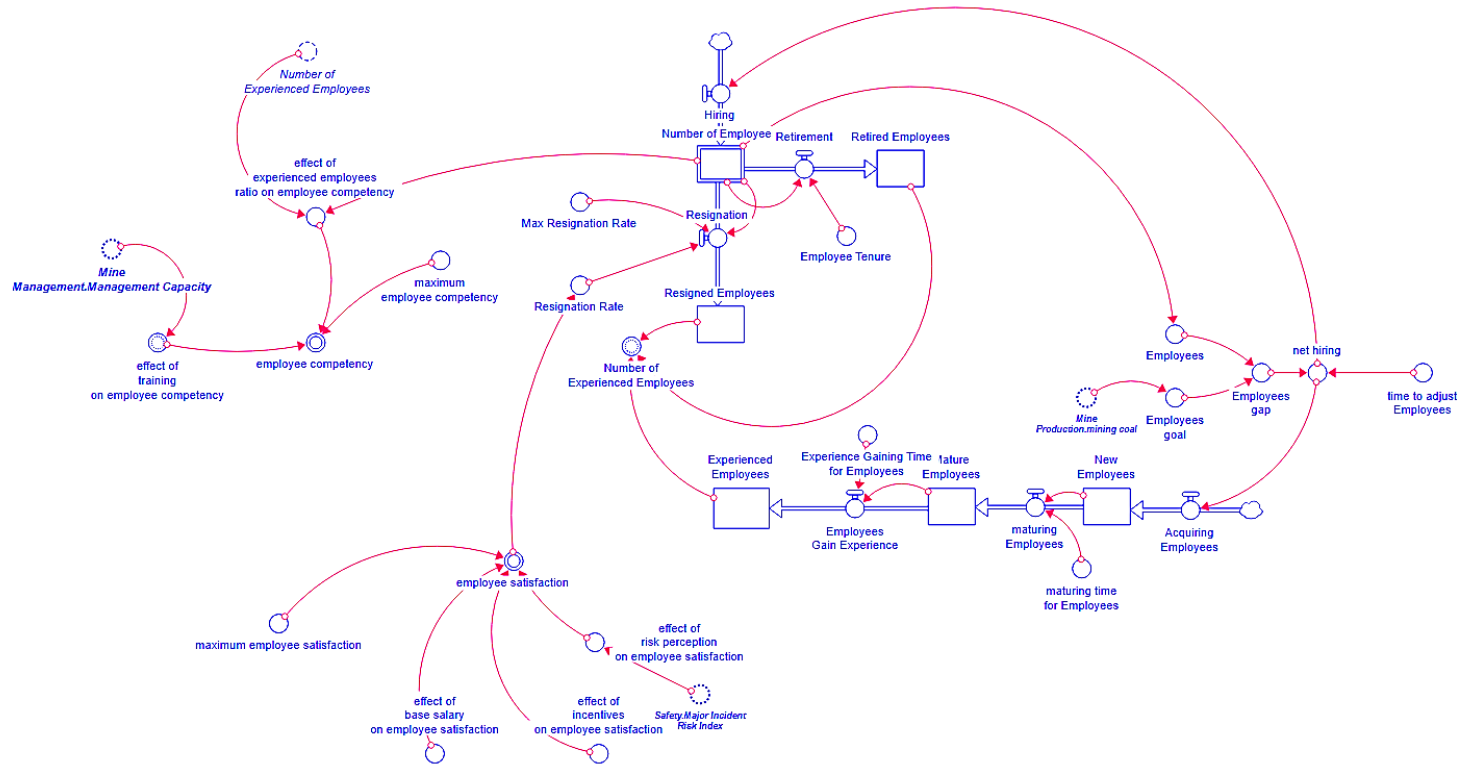

Figure 4-8 The Human Resources Subsystem

Table 4-5 Diagram Parameters and Variables of the Human Resources Subsystem

Name	Type	Variable explanation	Equation	Units
Experienced Employees(t)	Stock	The stock of experienced employees.	$\text{Experienced Employees}(T - dt) + (\text{Employees Gain Experience}) * dt$	People
Mature Employees(t)	Stock	The stock of mature employees.	$\text{Mature Employees}(T - dt) + (\text{Maturing Employees} - \text{Employees Gain Experience}) * dt$	People
New Employees(t)	Stock	The stock of newly hired employees.	$\text{New Employees}(T - dt) + (\text{Acquiring Employees} - \text{Maturing Employees}) * dt$	People
Number Of Employees(t)	Stock	The stock of employees	$\text{Number Of Employees}(T - dt) + (\text{Hiring} - \text{Retirement} - \text{Resignation}) * dt$	People
Resigned Employees(t)	Stock	The stock of resigned employees	$\text{Resigned Employees}(T - dt) + (\text{Resignation}) * Dt$	People
Retired Employees(t)	Stock	The stock of retired employees	$\text{Retired Employees}(T - dt) + (\text{Retirement}) * dt$	People
Acquiring Employees	Flow Regulator	Net hiring rate of employees to close the employee gap	$\text{INT}(\text{Net Hiring})$	People/Month
Employees Gain Experience	Flow Regulator	The rate of employees that gain a certain time of experience	$\text{INT}(\text{Mature Employees} / \text{Experience Gaining Time For Employees})$	People/Month
Hiring	Flow Regulator	The rate of hiring new employees	Net Hiring	People/Month
Maturing Employees	Flow Regulator	The rate of employees gaining basic experience in a certain time.	$\text{INT}(\text{New Employees} / \text{Maturing Time For Employees})$	People/Month
Resignation	Flow Regulator	The rate of resignation assuming no resignation in the first m months.	$\text{IF}(\text{TIME} > \text{User-defined constant value}) \text{ THEN } (\text{Number Of Employees} * \text{Resignation Rate}) \text{ ELSE } (0)$	People/Month
Retirement	Flow Regulator	The rate of retirement assuming m months tenure time.	$\text{IF}(\text{TIME} > \text{User-defined constant value}) \text{ THEN } (\text{Number Of Employees} / \text{Employee Tenure}) \text{ ELSE } (0)$	People/Month

Table 4-5 Diagram Parameters and Variables of the Human Resources Subsystem (cont'd)

Name	Type	Variable explanation	Equation	Units
Effect Of Base Salary On Employee Satisfaction	Convertor	Base salary effect on the satisfaction selected as a constant [0,1]	User-defined constant value	Dimensionless
Effect Of Incentives On Empl.Satisfaction	Convertor	A constant value index for the effect of incentives on satisfaction [0,1]	User-defined constant value	Dimensionless
Effect Of Risk Perception On Employee Satisfaction	Convertor	The effect of risk perception due to unsafe conditions on satisfaction	1-Major Incident Risk Index	Dimensionless
Effect Of Training On Employee Competency	Convertor	The training effect on employee competency based on the time allocated for training	Management Capacity/100	Dimensionless
Effect of Experienced Employees Ratio on Employee Competency	Convertor	Experience effect on Employee competency	(Number of Experienced Employees)/(Number of Employees)	Dimensionless
Employee Competency	Convertor	Employee competency	Maximum Employee Competency * (MAX(0.5 , MIN(1 , (((1*Effect Of Training On Employee Competency+1.2*Effect Of Experienced Employees Ratio On Employee Competency)/2.2))))	Percent
Employee Satisfaction	Convertor	Employee satisfaction factor as a percent value	Maximum Employee Satisfaction * (1.25*Effect Of Base Salary On Employee Satisfaction + 0.75*Effect Of Incentives On Employee Satisfaction + 1*Effect Of Risk Perception On Employee Satisfaction)/3	Percent
Employee Tenure	Convertor	Coal mining workers' tenure taken as m months.	User-defined constant value	Months
Effect Of Base Salary On Employee Satisfaction	Convertor	Base salary effect on the satisfaction selected as a constant [0,1]	User-defined constant value	Dimensionless
Employees	Convertor	The actual number of employees at a time	Number Of Employees	People

Table 4-5 Diagram Parameters and Variables of the Human Resources Subsystem (cont'd)

Name	Type	Variable explanation	Equation	Units
Employees Gap	Convertor	The gap between the target and the actual number of employees	Employees Goal - Employees	People
Employees Goal	Convertor	The target number of employees based on the previous months mine production and a user-defined average productivity	Mining Coal/User-Defined Value	People
Experience Gaining Time For Employees	Convertor	The time delay factor of m months for gaining experience	User-defined constant value	Month
Maturing Time For Employees	Convertor	The time delay factor of m months for gaining working knowledge	User-defined constant value	Month
Maximum Employee Competency	Convertor	A limit percent value for employee competency	User-defined constant value	Percent
Maximum Employee Satisfaction	Convertor	A limit percent value for employee satisfaction	User-defined constant value	Percent
Maximum Resignation Rate	Convertor	A rate of resignation where all of the employees are dissatisfied	User-defined constant value	Percent
Net Hiring	Convertor	The net hiring due to the employee gap, including the delay time for the hiring process	Employees Gap / Time To Adjust Employees	People/ Month
Number Of Experienced Employees	Convertor	Number of experienced workers at a given time	Experienced Employees-INT(Resigned Employees*0.5)-Retired Employees	People
Resignation Rate	Convertor	The rate of resigning employees	$((100-\text{Employee Satisfaction})/100)*0.01$	Per Month
Time To Adjust Employees	Convertor	The time delay factor due to HR processes when hiring new employees	User-defined constant value	Month

#### **4.1.5.1 The Hiring Process**

The hiring process combines three sections: Hiring to close the employee gap, the aging flow of new employees to gain experience in time, and the balancing stocks of hired, retired, and resigned employees.

Figure 4-9 shows the hiring section of the subsystem. According to the model, the gap between the actual number of employees and the employee goal is the reason for adopting a hiring process. This process is delayed due to interviews and other internal human resources processes. This delay time is labeled as the time to adjust employees.

The acquired employees are assumed to have no experience initially, and they gain experience in time. Employees gaining experience in time is characterized by an aging flow structure. It means that the rate of employee acquisition fills the stock of new employees, and these employees mature at a given time of delay. The maturing process can be defined as the time required for employees to have a basic knowledge of the workflow. These employees gain experience in time, and these experienced employees tend to have more productivity and more safety awareness as they have more profound knowledge of the daily tasks.

The percentage of experienced employees allows for the estimation of the experience factor in the overall employee competency. The number of workers at any given time is the stock of hired personnel subtracted from the retired and resigned employees. The model assumes that each personnel retires as soon as they fulfill their tenure. People also leave their jobs due to low satisfaction, which is triggered by economic, cultural, or personal parameters.

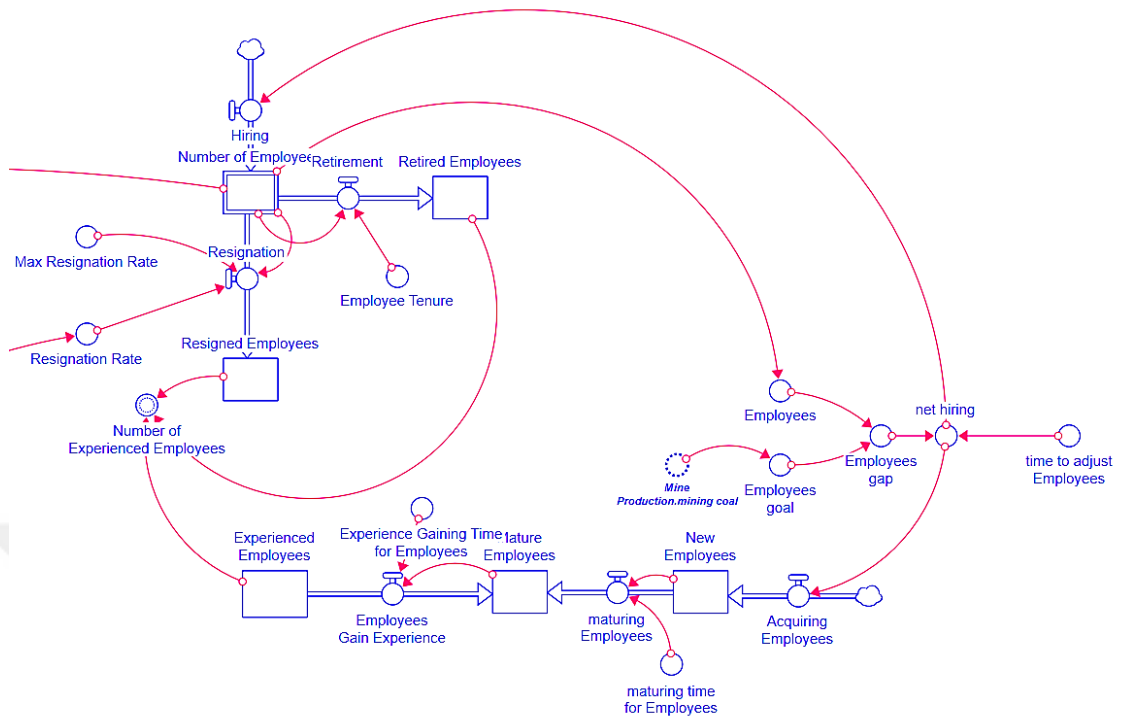

Figure 4-9 Hiring Processes Stock-and-Flow diagram

#### 4.1.5.2 Employee Competency

One of the effective factors of the human resources subsystem is employee competency. It encompasses the competency of all the employees, including frontline workers, supervisors, and mid-level managers, and excludes the competency of high-level managers. Employee competency is characterized by combining the effects of training and experience. These factors together give the employee competencies. The experience effect is explained in the hiring process section, and the variable is taken as the percent ratio of experienced employees to total employees.

The training effect on competency, however, depends on managerial decisions. This training component encompasses technical and practical training to enhance staff performance and is based on the time allocated for this activity. Figure 4-10 depicts

the training effect model, which is influenced by management capacity, and the outcome is used by employee competency, which influences employee productivity and personal commitment to safety.

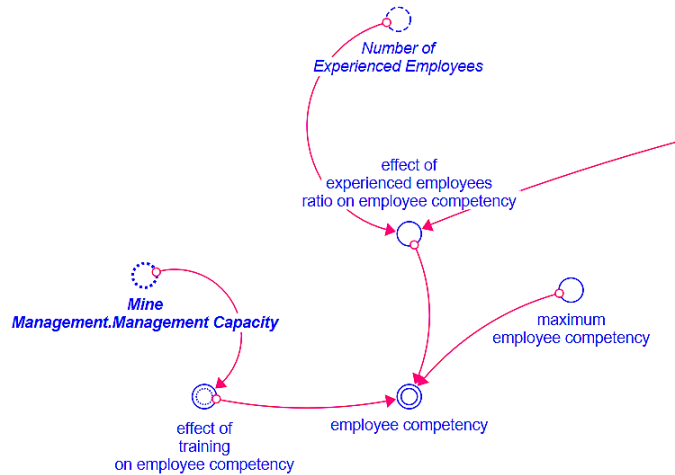

Figure 4-10 Employee Competency Model

Along with the personal satisfaction of employees, employee competencies and hiring processes constitute the human resources subsystem. In the human resources subsystem, the employee satisfaction factor is taken as a combination of external variables. It means that the dynamic feature of this satisfaction is excluded from the model.

#### 4.1.6 The Mine Management Subsystem

The mine management subsystem aims to present the managerial effects on safety regarding the major incident potential. The rationale behind this is that both safe technology investments and the effectiveness of the safety management system depend heavily on the administrative properties of the coal mining company.

Although these decisions vary widely depending on the company structure and there are governance indices developed in the literature, the complexity of the management is left out of the scope of the study. Therefore, only two outcomes of

this subsystem are encompassed in the model construction. These are the investment decisions for safe technologies and management capacity. The mine management subsystem is given in Figure 4-11.

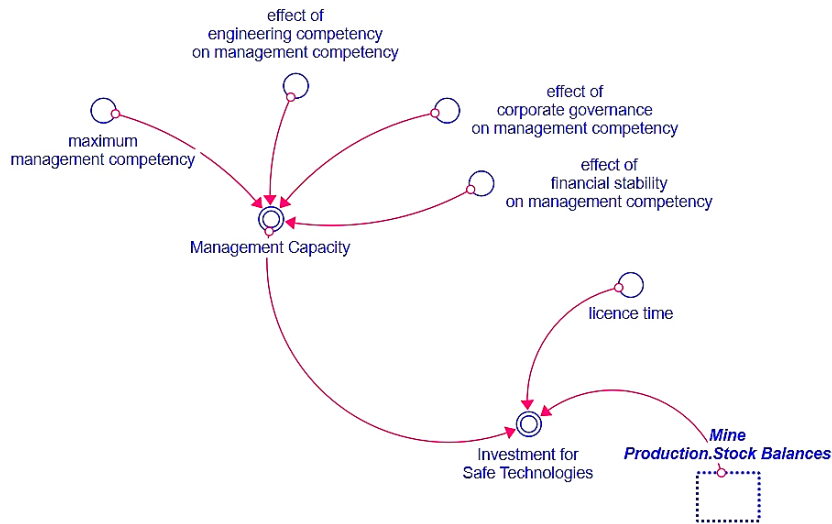

Figure 4-11 The Mine Management Subsystem

The model takes the management capacity as a constant index value as a percentage of a predetermined maximum value. It is characterized by the combining effects structure, and the effective parameters are all external constants regarding the corporate, financial, and engineering capacities. In addition, investments in safe technologies are another outcome of this subsystem. The management decision is based on a logical algorithm combining license time, management capacity, and financial depth. A profitable mine with resilient management is expected to invest in safe technologies if only the mine license is reliable. When the license time left is lower than a particular value, the management is not expected to invest in safe technologies. However, when there is enough time to invest, the resource allocation depends on management capacity and financial balances. The model assumes that with higher engineering competency and corporate governance, the management decisions favor more investment in safe technologies. Variables and parameters of the mine management subsystem are given in Table 4-6.

Table 4-6 Diagram Parameters and Variables of the Mine Management Subsystem

Name	Type	Variable explanation	Equation	Units
Effect Of Corporate Governance On Mgmt Competency	Convertor	A constant factor selected for corporate governance effect on management competency [0,1]	User-defined constant value	Dimensionless
Effect Of Eng' Competency On Mgmt Competency	Convertor	A constant factor selected for engineering competency effect on management competency [0,1]	User-defined constant value	Dimensionless
Effect Of Fin.Stability On MgmtCompetency	Convertor	A constant factor selected for financial stability effect on management competency [0,1]	User-defined constant value	Dimensionless
Investment For Safe Technologies	Convertor	The algorithm for management decisions to invest in safe technologies.	PULSE((IF((Licence Time-TIME > 60) AND (Mine Production.Stock Balances>1000000) AND (Management Capacity>0.7)) THEN(Mine Production.Stock Balances/5) ELSE IF ((Licence Time-TIME > 60) AND (Mine Production.Stock Balances>1000000) AND (Management Capacity>0.5)) THEN (Mine Production.Stock Balances/10) ELSE (0)), 1, 12)	
License Time	Convertor	A constant time value for end-of-license time	User-defined constant value	Months
Management Capacity	Convertor	A percent index for the corporate capacity for management.	Maximum Management Competency * (1.2*Effect Of Engineering Competency On Management Competency + 1.3*Effect Of Corporate Governance On Management Competency +1* Effect Of Financial Stability On Management Competency)/3.5	Percent
Max.Management Competency	Convertor	A maximum value for management competency as a percentage	100	Percent

## **4.2 Implementation of the Developed Model for a Hypothetical Mine**

This section will apply the developed system dynamics model for a hypothetical input dataset that can potentially represent the conditions of a typical underground coal mining company in Türkiye. It should be noted that the model outcomes are sensitive to the values of parameters and initial values of the variables. Therefore, different mines may have diversified results.

### **4.2.1 Input Dataset**

For testing the model, the model was computed for a typical underground coal mine in Türkiye using Stella Architect v.3.6. A hypothetical underground coal mine with a capacity of 1.8 million tonnes of run of mined coal per year was selected for the study. The selected mine initially had a total of 350 employees, 100 of whom were already experienced in underground coal mining. Five years of experience is taken as a threshold for employees. After that length of service, the employee is recognized as an experienced employee.

The external audit frequency is selected once every 12 months, with the first audit conducted on the 10<sup>th</sup> month. Corrective actions for half of the unsafe conditions stock are taken during each audit.

Coal prices are converted in USD from a typical Turkish lignite market price. The values are given in graph data that change over time, considering the fluctuating exchange rates from the Turkish Lira to the USD. In brief, the production cost is 16 dollars per tonne of coal production. Table 4-7 tabulates the model inputs of this hypothetical underground coal mine.

Table 4-7 A Hypothetical Dataset for the Model Implementation

Subsystem	Name	Type	Value	Unit
Safety	MCS(t)	Stock	Initial Value: 80	Percent
	PCS(t)	Stock	Initial Value: 80	Percent
	Unsafe Conditions(t)	Stock	Initial Value: 0	Number
	1 <sup>st</sup> degree safety critical roles	Convertor	0.2	Dimensionless
	2 <sup>nd</sup> degree safety critical roles	Convertor	0.5	Dimensionless
	3 <sup>rd</sup> degree safety critical roles	Convertor	0.3	Dimensionless
	Average number of risky behavior	Convertor	1	(Number/Month) /People
	Effect of Safe Technologies on Hazard Factor	Convertor	0.02	
	Interventions due to External Audits	Convertor	PULSE (0.5, 10, 12)	Number/Month
	Maximum Tolerable MIRI	Convertor	0.8	Dimensionless
	Maximum MCS	Convertor	100	Percent
	Maximum PCS	Convertor	100	Percent
	Mine Hazard Factor	Convertor	1	Dimensionless
	Normal MCS	Convertor	80	Percent
	Normal PCS	Convertor	80	Percent
	Risky behavior weight for 1 <sup>st</sup> degree	Convertor	0.7	Dimensionless
	Risky behavior weight for 2 <sup>nd</sup> degree	Convertor	0.4	Dimensionless
	Risky behavior weight for 3 <sup>rd</sup> degree	Convertor	0.1	Dimensionless
	Time to adjust MCS	Convertor	3	Month
	Time to adjust PCS	Convertor	3	Month
Major Incident Risk Index (MIRI)	Convertor	Unsafe Cond. /2,500	Dimensionless	
Mine Production	Run of Mine Coal (t)	Stock	Initial Value: 0	tonnes
	Sellable Coal Stock (t)	Stock	Initial Value: 0	tonnes
	Coal Market Demand	Convertor	100,000	tonnes / Month
	Employee Productivity Benchmark	Convertor	250	(tonnes/Month)/People
	Maximum Mining Capacity	Convertor	150,000	tonnes/Month
	Minimum Processing Time	Convertor	1	Months
	Processing Capacity	Convertor	120,000	tonnes/Month
	Mining Coal	Flow Regulator	m: 0.8	Dimensionless for m
	Production Costs	Convertor	16/0.6	\$/Tonne
	Target Processing	Convertor	120,000	tonnes/Month
CAPEX	Convertor	50 M\$, 60 <sup>th</sup> month, 60 months	\$/Month	

Table 4-7 A Hypothetical Dataset for the Model Implementation (cont'd)

	New Employees	Stock	Initial Value: 250	People
	Mature Employees	Stock	Initial Value: 0	People
	Experienced Employees	Stock	Initial Value: 100	People
	Number of Employees	Stock	Initial Value: 350	People
	Resigned Employees	Stock	Initial Value: 0	People
	Resigned Employees	Stock	Initial Value: 0	People
	Resignation	Flow Regulator	m: 24	People/Month
	Retirement	Flow Regulator	m: 180	People/Month
	Effect Of Base Salary On Employee Satisfaction	Convertor	1	Dimensionless
Human Resources	Effect Of Incentives On Empl.Satisfaction	Convertor	1	Dimensionless
	Employee Tenure	Convertor	180	Months
	Employees Goal	Convertor	350	People
	Experience Gaining Time For Employees	Convertor	60	Month
	Maturing Time For Employees	Convertor	12	Month
	Maximum Employee Competency	Convertor	100	Dimensionless
	Maximum Employee Satisfaction	Convertor	100	Percent
	Time To Adjust Employees	Convertor	3	Month
	Effect Of Corporate Governance On Mgmt Competency	Convertor	1	Dimensionless
	Effect Of Eng' Competency On Mgmt Competency	Convertor	1	Dimensionless
Mine Management	Effect Of Fin.Stability On MgmtCompetency	Convertor	1	Dimensionless
	Licence Time	Convertor	240	Months
	Max.Management Competency	Convertor	100	Percent

## 4.2.2 Implementation Results

The time frame used to simulate is 20 years to test the model behavior in the long term. As the time units were selected as months and no fractional runs were used, the simulation calculated the results along the 240 months.

### *Major Incident Risk Index*

The primary target outcome of the model constructed is to simulate the behavior of major incident potential of underground coal mines in Türkiye. The modeler used a constructed index for major incident potential based on the number of unsafe conditions piled up by human risky behavior and depleted by human behavior and external/internal audits. As given in Figure 4-12, the simulation returned index

values that oscillate through time. This behavior is due to the corrective actions that deplete the stock of unsafe conditions.

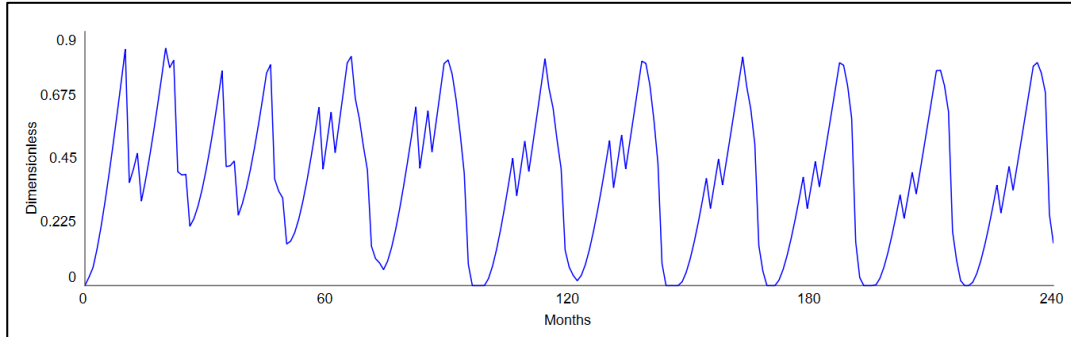

Figure 4-12 Variation of the Major Incident Risk Index in Time

The oscillating structure emphasizes the critical influence of audits on the disaster potential as the model suggests that audits aim to correct the stocked unsafe conditions at a given time. It should be noted that every audit and inspection has its efficiency, and this efficiency has a limit, so these actions alone are inadequate to eliminate major incident risks. Audits and inspections are discrete events that play an essential role in safety improvements; however, they have limited long-term effects as independent human actions accumulate unsafe conditions.

The results show that although the major incident potential oscillates, the lower limit of this oscillation reaches its lowest after about 90 months. It is linked to the number of experienced employees who are assumed to deplete the stock of unsafe actions at a higher rate. The model does not allow the user to eliminate unsafe human actions, as these are seen as normal outcomes of the daily production routine and the inherent hazard potential of an underground coal mine. Even though there are short periods where the accumulation is zero due to the cessation of production, the major incident risk is never eliminated. The critical finding of the model output for the major incident risk index is that the coal mine's potential for a catastrophic event fluctuates over time. It is an expected yet significant result that for a high-hazard workplace, safety interventions cannot be ceased for any reason as the system tends to drift into failure.

### *Management Commitment to Safety*

Management commitment to safety is an important factor that affects corrective actions due to internal safety processes. According to the model, the pressure on the management to prioritize safety is based on the risk perception of the management. The peaks in Figure 4-13 reflect the reactive behavior after the events where that major incident risk index exceeds the threshold limit. This risk threshold is a determinant factor where the emphasis turns to safety.

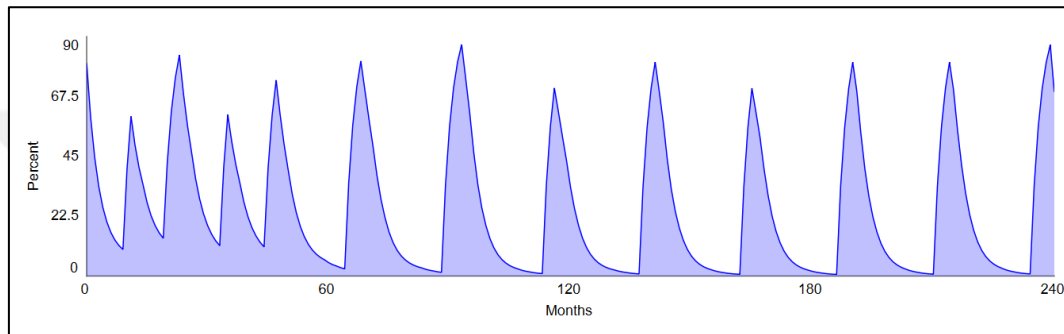

Figure 4-13 Variation of the Management Commitment to Safety in Time

The simulation results show that the major safety risk index has the highest impact on the pressure to change the management commitment to safety. The management's drive to safety is a constant value, continuously pulling the management's attention from safety. However, the risk perception for the management overcomes this effect when it reaches its threshold.

### *Personal Commitment to Safety*

With the given values, as shown in Figure 4-14, the simulation resulted in oscillating personal commitment to safety. The peaks are similar to the peaks of the management commitment to safety. The causes of the oscillating behavior of personal commitment to safety are due to three factors: major incident risk index, the effect of management commitment to safety, and employee competency.

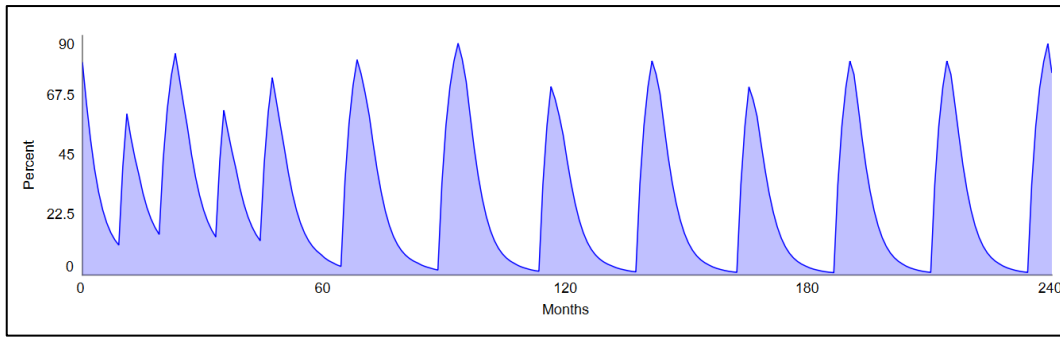

Figure 4-14 Variation of the Personal Commitment to Safety in Time

The model considers several factors for the retention of experienced workers, and the complexity of the human resources processes is included in the model. As shown in Figure 4-15, risk perception effectively reduces employee satisfaction, and a slight recurrent decrease in satisfaction is also observable.

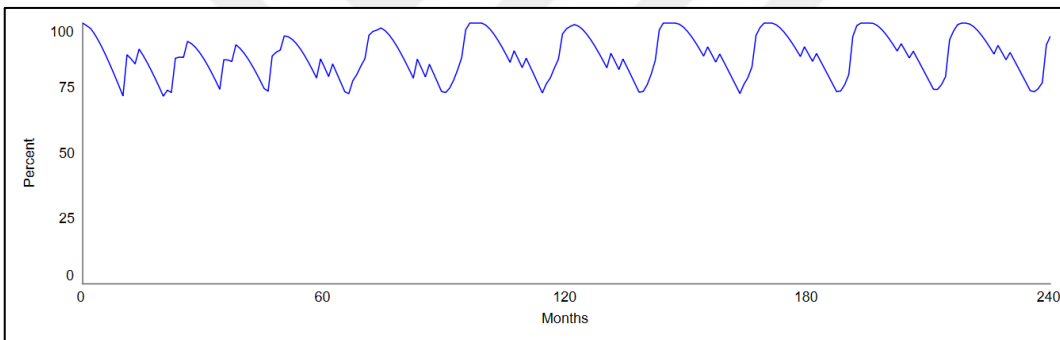

Figure 4-15 Variation of the Employee Satisfaction in Time

### *Employee Competency*

Employee competency is a factor that indirectly influences the personal commitment to safety. It has a relatively smooth curve over the simulation time. The retirement of employees after 15 years results in a decrease in competency **Error! Reference source not found.** People may also resign from the company due to their dissatisfaction, and a portion of it would be from the experienced workers. As a result, the company loses experienced workers and faces a decrease in its employees' overall competency. Therefore, the number of experienced employees increases in

the first years and then starts to decrease after reaching its peak after about 12 years, as seen in Figure 4-16.

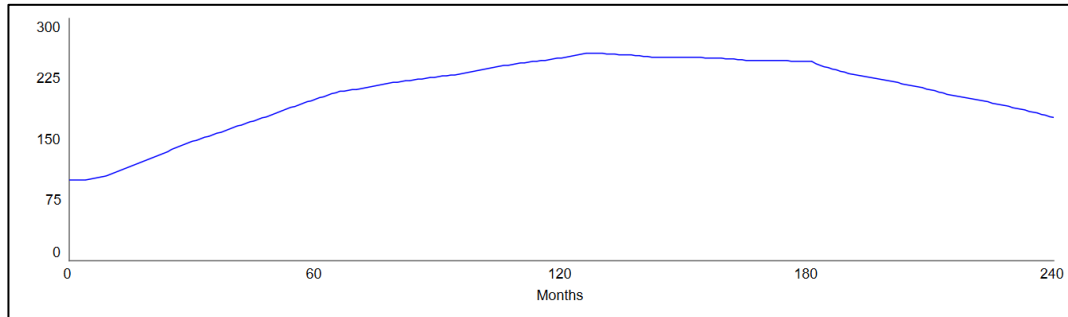

Figure 4-16 Variation of the Number of Experienced Employees in Time

The competency curve shows a similar but smoother behavior with the ratio of experienced employees. It should be noted that experience has a major effect on competency, whereas training is a safeguard, especially when losing experienced employees. The variation in employee competency over the simulated 20 years is given in Figure 4-17.

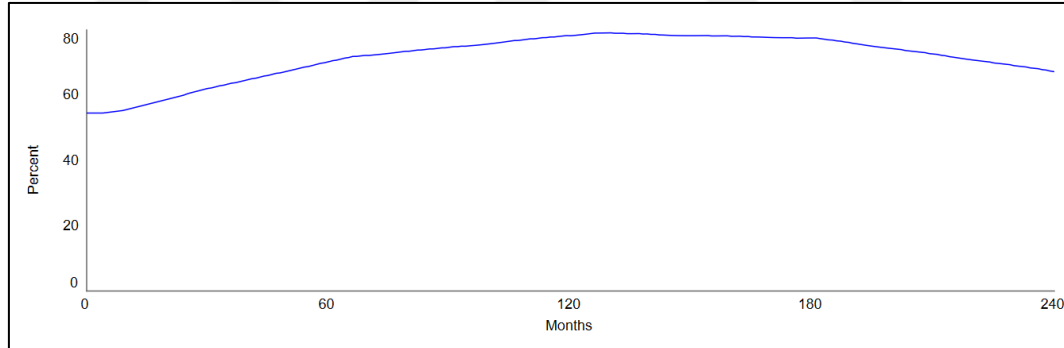

Figure 4-17 Variation of the Employee Competency in Time

### *Coal Production*

According to the simulation results, coal production fluctuates between limits exerted by the user. It is also noted that the potential for the incident has risen enough to cause production cessations during the mine life. Figure 4-18 shows the simulation results for coal production over 20 years. Although coal production fluctuates

between its limits, stop work actions due to the major incident risk index exceeding an induced threshold limit.

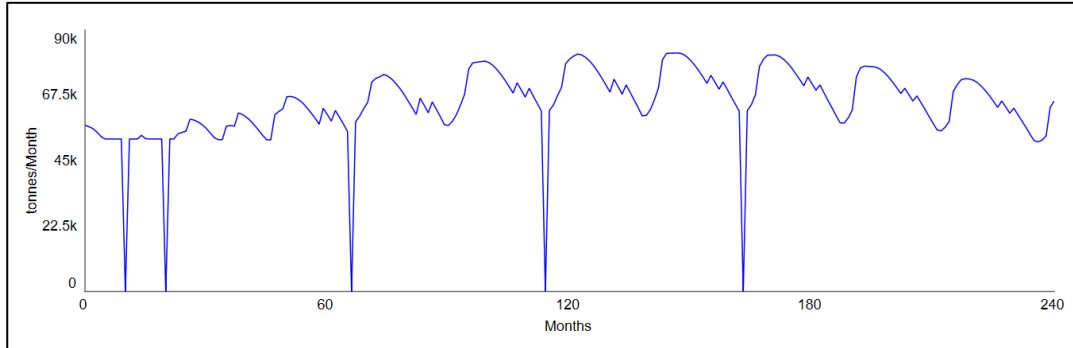

Figure 4-18 Variation of the Run of Mined Coal Production Rate in Time

The simulation also depicts a balanced behavior in employee productivity, as shown in Figure 4-19. The employee's productivity depends on the employee's competency and the slight curvature over time results from the employee competency curve. However, it is also influenced by employee satisfaction and gives its slightly oscillating behavior over time. It should also be noted that employee satisfaction notably influences the mine production rate.

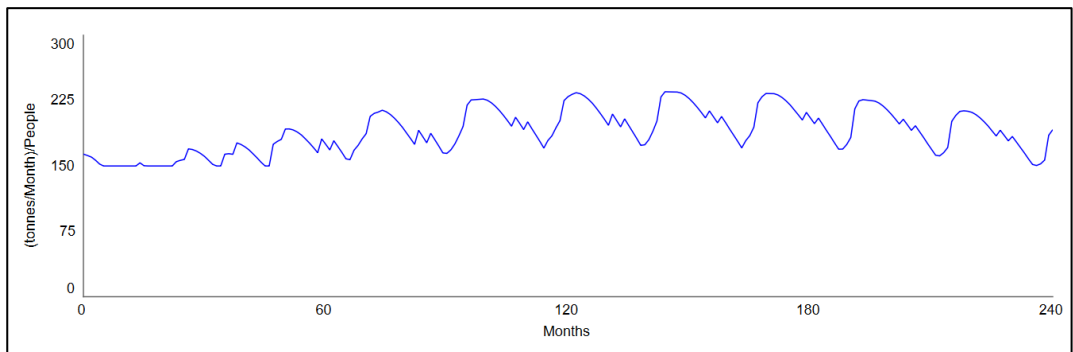

Figure 4-19 Variation of the Employee Productivity in Time

As seen in Figure 4-20, several technological investment moments are captured throughout the simulation period. In addition to the production costs and capital expenditure, technological investment decisions are made. The cessation of

investments in the last five years reflects the reluctance to spend money on improvements when the license deadline comes closer.

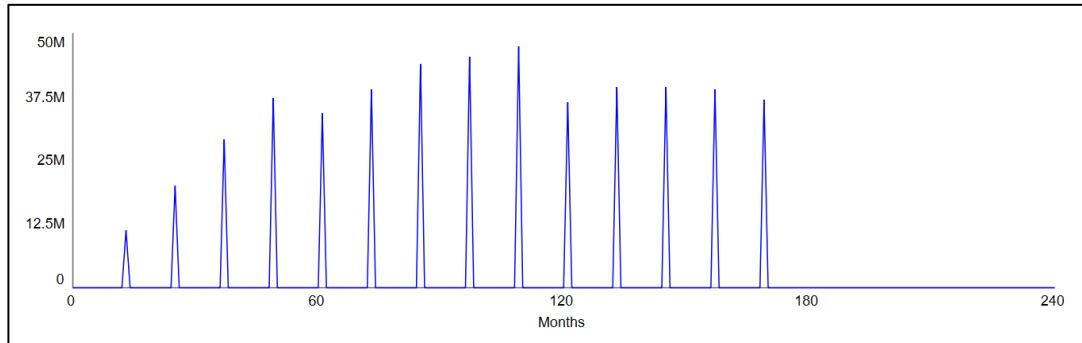

Figure 4-20 Variation of the Investment in Safe Technologies in Time



## CHAPTER 5

### CONCLUSIONS AND RECOMMENDATIONS

#### 5.1 Conclusions

In the Turkish coal mining industry context, the recurrence of the major incidents such as firedamp explosions and mine fires that result in multiple fatalities was investigated concerning its nonlinear interactions. The System Dynamics Modeling has provided valuable insights into the complex dynamics of the industry. The study aimed to unravel the underlying dynamic complexity behind this recurrence by using causal loop diagrams and stock-and-flow diagrams coupled with a simulation model.

The findings of this study shed light on several crucial factors influencing the system dynamics of the Turkish coal mining industry. As a result, the conclusions drawn from the study are given below;

- The most crucial finding of the model is that the major incident potential of a coal mine is fluctuating over time depending on many other variables. The peaks along the time are the indicators of vulnerable times and the recurrence of these peaks show that the mine becomes susceptible to catastrophic events recurrently.
- The model emphasizes the importance of the continuity of the safety interventions and both internal and external audits play an important role in correcting the unsafe conditions. The accumulation of major incident potential within coal mines aligns with the "drift into failure" phenomenon, emphasizing the need for ongoing, adaptive safety strategies rather than relying solely on initial investments in a reliable system.

- It has been identified that the effect of internal audits is induced by the pressure on the management to increase their resource allocation in safety. An alternative approach to support this effect can be increasing the risk thresholds of mine management as they tend to react to the exceeding risk threshold. Increasing safety awareness of mine managers, therefore might be a leverage point.
- External audits are emerged as an important factor when depleting the stock of accumulated unsafe conditions. However, it should be noted that these are discrete exogenous events with an efficiency factor which have short term effects.
- The study underscores the importance of investing in the workforce and reducing employee turnover as critical factors for the safety and productivity of coal mining operations. Along the time, losing experienced employees might be a solid phenomenon, therefore high-quality trainings worth for investing in order to keep the younger workforce ready and competent.
- The license deadlines are an important factor when mine managers make decisions on investing on the safe technologies. Policymakers can focus on finding solutions on the process of license renewal, considering its effect on the adoption of safe technologies.

Overall, the findings of this study suggest leverage points in the system that offer actionable insights for policymakers, industry stakeholders, and safety professionals.

## **5.2 Recommendations**

For future studies in this area, several recommendations can be considered to enhance the research findings as follows;

- Future studies may benefit from incorporating real-time data and monitoring systems. It will provide a more dynamic and up-to-date representation of the

coal mining system, enabling researchers to capture evolving trends and respond promptly to changing conditions.

- A more detailed description of a single catastrophic event scenario can be studied. The potential factors for a methane explosion scenario can be embedded in the safety subsystem do research for leverage points.
- The mine management subsystem can incorporate the dynamic variables of corporate governance. This can be done by further research on the corporate governance indices and the factors influencing the dimension of corporate governance.
- The effect of production premiums is indirectly embedded in the model via management drive to produce. Incorporating the effects of production premiums more directly on the personal commitment to safety loops will also be beneficial for future models.
- Conducting field validation of the System Dynamics model may strengthen its reliability and accuracy. Comparing the model predictions with actual data from coal mining operations can provide valuable insights into the model's effectiveness in representing real-world dynamics.
- Exploring the impact of external factors such as environmental regulations, geopolitical influences, and technological advancements on the coal mining industry can provide additional insight.
- Combining System Dynamics modeling with qualitative research methods, such as ethnography, case studies and expert group studies can offer a deeper understanding of the human and organizational aspects influencing safety dynamics in coal mining.
- Comparing the dynamics of the Turkish coal mining industry with similar industries globally can provide valuable insights into industry-specific challenges and potential universal solutions.

By incorporating these recommendations, future studies can contribute to a more comprehensive understanding of the complex interactions leading to catastrophic coal mine incidents in Türkiye.



## REFERENCES

- Abbaspour, H., Drebenstedt, C., & Dindarloo, S. R. (2018). Evaluation of safety and social indexes in the selection of transportation system alternatives (Truck-Shovel and IPCCs) in open pit mines. *Safety Science*, *108*(October 2017), 1–12. <https://doi.org/10.1016/j.ssci.2018.04.020>
- Ahmad, S., Mat Tahar, R., Muhammad-Sukki, F., Munir, A. B., & Abdul Rahim, R. (2016). Application of system dynamics approach in electricity sector modelling: A review. *Renewable and Sustainable Energy Reviews*, *56*, 29–37. <https://doi.org/10.1016/j.rser.2015.11.034>
- Barlas, Y. (2007). Leverage points to march “upward from the aimless plateau”. *System Dynamics Review Vol. 23, No. 4. 469–473*. Published online in Wiley InterScience. <https://doi.org.10.1002/sdr.389>
- Boukas, D., & Kontogiannis, T. (2019). A system dynamics approach in modeling organizational tradeoffs in safety management. *Human Factors and Ergonomics In Manufacturing*, *29*(5), 389–404. <https://doi.org/10.1002/hfm.20795>
- Brady Heywood. (2019). *Brady Review - Review of all fatal accidents in Queensland mines and quarries from 2000 to 2019* (pp. 60-63). Online Report. <https://www.parliament.qld.gov.au/documents/tableOffice/TabledPapers/2020/5620T197.pdf>
- Busch, C. (2018). *Heinrich’s Local Rationality: Shouldn’t ‘New View’ Thinkers Ask Why Things Made Sense To Him?*. MSc Thesis in Human Factors and System Safety, Lund University. <https://lup.lub.lu.se/student-papers/record/8975267/file/8975268.pdf>
- Cooke, D.L. (2003). A system dynamics analysis of the Westray mine disaster. *System Dynamics Review Vol. 19, No. 2: 139–166*. Published online in Wiley InterScience. <https://doi.org.10.1002/sdr.268>

- Cosenz, F., & Noto, G. (2016). Applying System Dynamics Modelling to Strategic Management: A Literature Review. *Systems Research and Behavioral Science*, 33(6), 703–741. <https://doi.org/10.1002/sres.2386>
- Darabi, N., & Hosseinichimeh, N. (2020). System dynamics modeling in health and medicine: a systematic literature review. *System Dynamics Review*, 36(1), 29–73. <https://doi.org/10.1002/sdr.1646>
- Davahli, M. R., Karwowski, W., & Taiar, R. (2020). A system dynamics simulation applied to healthcare: A systematic review. In *International Journal of Environmental Research and Public Health* (Vol. 17, Issue 16, pp. 1–27). MDPI AG. <https://doi.org/10.3390/ijerph17165741>
- Dekker, S., Hollnagel, E., Woods, D., & Cook, R. (2008). Resilience Engineering: New directions for measuring and maintaining safety in complex systems. *Lund University School of Aviation*, 1, 1-6.
- Dekker, S. (2011). *Drift into Failure Sidney Dekker From Hunting Broken Components to Understanding Complex Systems* (1st ed., pp. 138-139). Ashgate Publishing Company.
- Featherston, C. R., & Doolan, M. (2012). *A Critical Review of the Criticisms of System Dynamics* [Conference]. The 30th International Conference of the System Dynamics Society. <https://proceedings.systemdynamics.org/2012/proceed/papers/P1228.pdf>
- Fontoura, W. B., & Ribeiro, G. M. (2021). System dynamics for sustainable transportation policies: A systematic literature review. *Urbe*, 13, 1–15. <https://doi.org/10.1590/2175-3369.013.E20200259>
- Goh, Y. M., Love, P. E., Brown, H., & Spickett, J. (2012a). Organizational accidents: A systemic model of production versus protection. *Journal of management studies*, 49(1), 52-76. <https://doi.org/10.1111/j.1467-6486.2010.00959.x>
- Goh, Y. M., Love, P. E. D., Stagbouer, G., & Annesley, C. (2012b). Dynamics of safety performance and culture: A group model building approach. *Accident*

*Analysis and Prevention*, 48, 118–125.  
<https://doi.org/10.1016/j.aap.2011.05.010>

Heinrich, H. W. (1931) *Industrial Accident Prevention: A Scientific Approach*. New York: McGraw-Hill.

Hollnagel, E. (2009). *The ETTO Principle: Efficiency-Thoroughness Trade-Off - Why Things That Go Right Sometimes Go Wrong?* Ashgate Publishing Limited.

Ibrahim Shire, M., Jun, G. T., & Robinson, S. (2018). The application of system dynamics modelling to system safety improvement: Present use and future potential. *Safety Science*, 106(May 2017), 104–120.  
<https://doi.org/10.1016/j.ssci.2018.03.010>

ILO International Labour Organization. (2016). Contractual arrangements in Turkey's coal mines : forms, extents, drivers, legal drivers and impact on OSH. Report No: 9789221309314. ILO Türkiye Ofisi, Ankara. (In Turkish)  
<https://www.ilo.org/wcmsp5/groups/public/---europe/---ro-geneva/---ilo-ankara/documents/publication/wcms458151.pdf>

Jiao, J., Jing, Y., & Pang, S. (2022). An Integrated Quantitative Safety Assessment Framework Based on the STPA and System Dynamics. *Systems*, 10(5).  
<https://doi.org/10.3390/systems10050137>

Kontogiannis, T., & Malakis, S. (2019). A system dynamics approach to the efficiency thoroughness tradeoff. *Safety Science*, 118, 709–723.  
<https://doi.org/10.1016/j.ssci.2019.06.011>

Koul, S., Falebita, O. A., Akinbami, J. F. K., & Akarakiri, J. B. (2016). System dynamics, uncertainty and hydrocarbon resources modelling: A systematic review. *Renewable and Sustainable Energy Reviews*, 59, 199–205.  
<https://doi.org/10.1016/j.rser.2015.12.088>

Le Coze, J. C. (2015). Reflecting on Jens Rasmussen's legacy. A strong program for a hard problem. *Safety science*, 71, 123-141.  
<https://doi.org/10.1016/j.ssci.2014.03.015>

- Leveson, N. (2004). A new accident model for engineering safer systems. *Safety science*, 42(4), 237-270. [https://doi.org/10.1016/S0925-7535\(03\)00047-X](https://doi.org/10.1016/S0925-7535(03)00047-X)
- Leveson, N. G., & Thomas, J. P. (2018). *STPA handbook*. Cambridge, MA, USA. [https://psas.scripts.mit.edu/home/get\\_file.php?name=STPA handbook.pdf](https://psas.scripts.mit.edu/home/get_file.php?name=STPA%20handbook.pdf)
- Leveson, N., Dulac, N., Zipkin, D., Cutcher-Gershenfeld, J., Carroll, J., & Barrett, B. (2006). Engineering Resilience into Safety-Critical Systems. In *Resilience engineering* (pp. 95-123). CRC Press.
- Liu, Q., Li, X., & Meng, X. (2019). Effectiveness research on the multi-player evolutionary game of coal-mine safety regulation in China based on system dynamics. *Safety Science*, 111(July 2018), 224–233. <https://doi.org/10.1016/j.ssci.2018.07.014>
- Ma, L., Liu, Q., Qiu, Z., & Peng, Y. (2020). Evolutionary game analysis of state inspection behaviour for coal enterprise safety based on system dynamics. *Sustainable Computing: Informatics and Systems*, 28(August). <https://doi.org/10.1016/j.suscom.2020.100430>
- MAGÜK. (2019). *Maden Güvenlik Kültürü (MAGÜK) Projesi Final Raporu*. (p 19, p43). T.C. Enerji ve Tabii Kaynaklar Bakanlığı, Ankara. (in Turkish)
- Martinez-Moyano, I.J., & Richardson, G.P. (2013). Best practices in system dynamics modeling. *System Dynamics Review Vol. 29, No. 2: 469–473*. Published online in Wiley InterScience. <https://doi.org/10.1002/sdr.1495>
- Mozier, J.D. (1999). *System Dynamics Modelling of Occupational Safety: A Case Study Approach*. PhD Thesis in Department of Management and Organization, University of Stirling, UK.
- Perrow, C. (1999). *Normal accidents: Living with high risk technologies*. Princeton university press.
- Rasmussen, J. (1988). Safety Control and Risk Management: Topics for Cross-Disciplinary Research and Development. In J. Rasmussen, & R. Batstone (Eds.), *Why do Complex Organizational Systems Fail?: Summary of*

*Proceedings of a Cross Disciplinary Workshop on "Safety Control and Risk Management"* World Bank Publications.

Rasmussen, J. (1990). The role of error in organizing behaviour. *Ergonomics*, 33(10-11), 1185-1199. <https://doi.org/10.1136/qhc.12.5.377>

Rodriguez-Ulloa, R. (2018). Systemic methodology for risks evaluation and management in the energy and mining sectors (SYSMEREM-EMS) using bayesian networks. *Journal of Decision Systems*, 27, 191–200. <https://doi.org/10.1080/12460125.2018.1468157>

Saldarriaga-Isaza, A., Arango, S., & Villegas-Palacio, C. (2015). A behavioral model of collective action in artisanal and small-scale gold mining. *Ecological Economics*, 112, 98–109. <https://doi.org/10.1016/j.ecolecon.2015.02.002>

Selebalo, I. M., Scholes, M. C., & Clifford-holmes, J. K. (2021). A systemic analysis of the environmental impacts of gold mining within the blyde river catchment, a strategic water area of south africa. *Water (Switzerland)*, 13(3), 1–25. <https://doi.org/10.3390/w13030301>

Senge, P.M. (1990) *The Fifth discipline: the art and practice of the learning organization*. New York : Doubleday/Currency, c1990.

Shepherd, S. P. (2014). A review of system dynamics models applied in transportation. *Transportmetrica B: Transport Dynamics*, 2(2), 83-105. <https://doi.org/10.1080/21680566.2014.916236>

Sterman, J.D. (1983). Economic vulnerability and the energy transition. *Systems and Policy* 7(4), 259-301.

Sterman, J. D. (2000). *Business Dynamics: Systems Thinking and Modeling for a Complex World*. Boston : Irwin/McGraw-Hill, c2000.

Sterman, J.D. (2002). *System Dynamics: systems thinking and modeling for a complex world*. MIT Engineering Systems Division - Working Paper Series. <https://dspace.mit.edu/handle/1721.1/102741>

- Toft, Y., Dell, G. Klockner, K.K., & Hutton, A. (2012). *Models of Causation: Safety*. In HaSPA (Health and Safety Professionals Alliance), The Core Body of Knowledge for Generalist OHS Professionals. Tullamarine, VIC. Safety Institute of Australia.
- Tong, L., & Dou, Y. (2014). Simulation study of coal mine safety investment based on system dynamics. *International Journal of Mining Science and Technology*, 24(2), 201–205. <https://doi.org/10.1016/j.ijmst.2014.01.010>
- TBMM. (2014). *Manisa'nın Soma İlçesinde, Başta 13 Mayıs 2014 Tarihinde Olmak Üzere Meydana Gelen Maden Kazalarının Araştırılarak Bu Sektörde Alınması Gereken İş Sağlığı Ve İş Güvenliği Tedbirlerinin Belirlenmesi Amacıyla Kurulan Meclis Araştırması Komisyonu Raporu. (p547,557, 573, 581,612) - Türkiye Büyük Millet Meclisi, Ankara. (in Turkish)* <https://www.tbmm.gov.tr/sirasayi/donem24/yil01/ss680-bolum-2.pdf>
- TBMM. (2023). *Bartın'ın Amasra İlçesinde Meydana Gelen Maden Kazasının Tüm Yönleriyle Araştırılarak Benzer Kazaların Önlenmesine Yönelik Tedbirlerin Belirlenmesi Amacıyla Kurulan Meclis Araştırması Komisyonu Raporu. (p325-342). Türkiye Büyük Millet Meclisi, Ankara. (in Turkish).*
- TMMOB Maden Mühendisleri Odası. (2021). *Madencilikte Yaşanan İş Kazaları Raporu (2010-2020) (pp. 20-24). Online Report. (In Turkish)* [https://api.maden.org.tr/uploads/portal/resimler/ekler/f4e5d6912a\\_2079309069\\_ek.pdf](https://api.maden.org.tr/uploads/portal/resimler/ekler/f4e5d6912a_2079309069_ek.pdf)
- Torres, J.P. (2019). System Dynamics Review and publications 1985–2017: analysis, synthesis and contributions. *System Dynamics Review Vol. 35, No. 2: 160–176*. Published online in Wiley InterScience. <https://doi.org/10.1002/sdr.1628>
- Trimble, J. (2014). *Boundary concepts in system dynamics*. [Conference]. The 32<sup>nd</sup> International Conference of the System Dynamics Society. <https://proceedings.systemdynamics.org/2014/proceed/papers/P1175.pdf>

- Turner, B. L., Menendez, H. M., Gates, R., Tedeschi, L. O., & Atzori, A. S. (2016). System dynamics modeling for agricultural and natural resource management issues: Review of some past cases and forecasting future roles. *Resources*, 5(4). <https://doi.org/10.3390/resources5040040>
- Uriona, M., & Grobbelaar, S. S. (2019). Innovation system policy analysis through system dynamics modelling: A systematic review. *Science and Public Policy*, 46(1), 28–44. <https://doi.org/10.1093/scipol/scy034>
- Verrier, B., Smith, C., Yahyaei, M., Ziemski, M., Forbes, G., Witt, K., & Azadi, M. (2022). Beyond the social license to operate: Whole system approaches for a socially responsible mining industry. *Energy Research and Social Science*, 83(January 2021), 102343. <https://doi.org/10.1016/j.erss.2021.102343>
- Von Bertalanffy, L. (1969). General systems theory and psychiatry—an overview. *General systems theory and psychiatry*, 32(4), 33-46.
- Wang, J. F., Feng, L. J., & Zhai, X. Q. (2012). A System Dynamics Model of Flooding Emergency Capability of Coal Mine. *Przeglad Elektrotechniczny*, 88(9 B), 209–211.
- Wang, J., Lu, H., & Peng, H. (2008). System Dynamics Model of Urban Transportation System and Its Application. *Journal of Transportation Systems Engineering and Information Technology*, 8(3), 83-89. [http://dx.doi.org/10.1016/S1570-6672\(08\)60027-6](http://dx.doi.org/10.1016/S1570-6672(08)60027-6)
- Wiegmann, D.A.; Shappell, S.A. A human error analysis of commercial aviation accidents: Application of the Human Factors Analysis and Classification System (HFACS). *Aviat. Space Environ. Med.* 2001, 72, 1006–1016. <https://commons.erau.edu/publication/1216>
- Yang, L., Wang, X., Zhu, J., Sun, L., & Qin, Z. (2022). Comprehensive Evaluation of Deep Coal Miners' Unsafe Behavior Based on HFACS-CM-SEM-SD. *International Journal of Environmental Research and Public Health*, 19(17). <https://doi.org/10.3390/ijerph191710762>

- You, M., Li, S., Li, D., Cao, Q., & Xu, F. (2020). Evolutionary game analysis of coal-mine enterprise internal safety inspection system in China based on system dynamics. *Resources Policy*, 67(February), 101673. <https://doi.org/10.1016/j.resourpol.2020.101673>
- Yu, K., Zhou, L., Cao, Q., & Li, Z. (2019). Evolutionary game research on symmetry of workers' behavior in coal mine enterprises. *Symmetry*, 11(2). <https://doi.org/10.3390/sym11020156>
- Zanker, M., Bureš, V., & Tučník, P. (2021). Environment, business, and health care prevail: A comprehensive, systematic review of system dynamics application domains. *Systems*, 9(2), 28. <https://doi.org/10.3390/systems9020028>