



REPUBLIC OF TURKEY
ALTINBAS UNIVERSITY
Institute of Graduate Studies
Electrical and Computer Engineering

**IMPROVEMENT OF DATA TRANSMISSION IN
FIBER OPTICAL SYSTEMS USING VCSEL BASED
ERBIUM DOPED FIBER AMPLIFIER (EDFA)**

Ahmed Jamal Azeez ALYOUSUF

Master of Science

Supervisor

Prof. Dr. Osman Nuri UCAN

Istanbul, 2020

**IMPROVEMENT OF DATA TRANSMISSION IN FIBER OPTICAL
SYSTEMS USING VCSEL BASED ERBIUM DOPED FIBER AMPLIFIER
(EDFA)**

Ahmed Jamal Azeez ALYOUSUF

Information Technologies

Master of Science

ALTINBAŞ UNIVERSITY

2020

The thesis titled IMPROVEMENT OF DATA TRANSMISSION IN FIBER OPTICAL SYSTEMS USING VCSEL BASED ERBIUM DOPED FIBER AMPLIFIER (EDFA) prepared AHMED JAMAL AZEEZ ALYOUSUF and submitted on 12/10/2020 has been **accepted unanimously by of votes** for the degree of Master of Science in Electrical and Computer Engineering.

Prof. Dr. Osman Nuri UCAN

Supervisor

Thesis Defense Jury Members:

Prof. Dr. Osman Nuri UCAN

Faculty Of Engineering and
Architecture,

Altinbas University

Asst. Prof. Dr. Muhammad Ilyas

Faculty Of Engineering and
Architecture,

Altinbas University

Assoc. Prof. Dr. Adil Deniz DURU

Faculty of Physical Education
and Sports,

Marmara University

I hereby declare that this thesis meets all format and submission requirements of a Master of Science

Accepted by Altınbaş University Institute of Graduate Studies on the following date:

___/___/___

I hereby declare that all information in this document has been obtained and presented in accordance with academic rules and ethical conduct. I also declare that, as required by these rules and conduct, I have fully cited and referenced all material and results that are not original to this work.

Ahmed Jamal Azeez ALYOUSUF

DEDICATION

I devote and pledge this research work to my supervisor who is salient for guiding me through whole research work as well as my family for always assisting me in my hard time.



ACKNOWLEDGEMENTS

First and foremost, I would like to thank my supervisor Prof. Dr. Osman Nuri UCAN for guiding and helping me along the way in writing this dissertation. Discussing my progress, problems, and ideas with my supervisor Prof. Dr. Osman Nuri UCAN a couple of times every week helped me tremendously in understanding the logic behind the research. It made me better realize the technical need for this research work.



ABSTRACT

IMPROVEMENT OF DATA TRANSMISSION IN FIBER OPTICAL SYSTEMS USING VCSEL BASED ERBIUM DOPED FIBER AMPLIFIER (EDFA)

ALYOUSUF, Ahmed Jamal Azeez,

M.Sc., Electrical and Computer Engineering, Altınbaş University,

Supervisor. Prof. Dr. Osman Nuri UCAN

Date: October /2020

Pages: 48

The rapid growth of multi-media and data rich applications has driven the bandwidth demand for long-haul fiber optic links at unprecedented rates. At the same time, growing capacity demands also imposes challenges on bandwidth and interconnects in data centers. Optical fibers are continuing improving their performance to meet the bandwidth demand in both long haul and short reach applications. While continuing improvements in conventional fiber optic technologies will increase the system capacity further in a short term, recent studies show that the transmission capacity over single-mode optical fibers is rapidly approaching its fundamental Shannon limit. A Large capacity optical networks require flattened gain spectrum and large gain bandwidth of the optical networks. In this proposal an all-optical wavelength reuse technique employing cost effective power efficient vertical surface emitting laser (VCSEL) is proposed to address uplink data streaming from end-users by exploiting the same wavelength assigned to them. A saturated optical erbium-doped optical fiber amplifier (EDFA) and SO Amplifier are adopted to erase a directly modulated 0.6 Tbit/s data from an incoming downstream wavelength. We show that with EDFA saturation, the extinction ration of the incoming wavelength is reduced to less than 1 dBm, therefore allowing for wavelength re-modulation. A receiver sensitivity of -19.65 dBm and -17.86 dBm is attained for downstream and upstream data signals respectively. A total of 24.7 km single

mode fiber transmission is attained experimentally. This technique opens new perspectives towards development of efficient spectrum utilization for application in wavelength flexible optical networks with non-static flex-spectrum grids.

Keywords: VCSEL; EDFA; Error Free Data Transmission; Optical Link



TABLE OF CONTENTS

	<u>Pages</u>
ABSTRACT	vii
LIST OF FIGURES.....	xi
LIST OF TABLES.....	xiii
LIST OF ABBREVIATIONS	ix
1. INTRODUCTION.....	1
1.1 PRINCIPLE OF OPTICAL AMPLIFIERS	4
1.2 TYPES OF OPTICAL AMPLIFIERS	5
1.2.1 Semiconductor Optical Amplifiers.....	6
1.2.2 Fiber Amplifiers	6
1.2.3 Rare Earth Doped Fiber Amplifier.....	7
1.2.4 Raman Amplifier	8
1.2.5 Brillouin Fiber Amplifier.....	10
1.3 PROBLEM STATEMENT	10
1.4 BANDWIDTH LIMITATIONS	11
1.4.1 Bandwidth.....	11
1.5 SELECTION OF STUDY AREA.....	11
1.6 OBJECTIVES	12
1.7 ORGANIZATION OF THE THESIS	13
2. LITERATURE REVIEW.....	14
2.1 INFORMATION AND NOISE IN COMMUNICATION SYSTEMS	14
2.2 DIGITAL DIGITAL PROCESSING AND ASSEMENT OPTICAL DIGITAL.	15
2.2.1 Unidirectional Vs. Bidirectional Systems	15
2.2.2 All-Optical Systems.....	16
2.2.3 Non linearities in Optical Amplifier.....	17
2.2.3.1 Gain saturation.....	17
2.2.3.2 Four wave mixing and cross gain modulation.....	18

2.2.3.3	Polarization sensitivity of SOA	18
2.2.3.4	Phase noises of SOA	19
2.2.4	Gain-Bandwidth of Optical Amplifier.....	19
2.2.4.1	Gain flattening	20
2.3	BASIC PRINCIPLE OF EDFA	21
2.4	CONCLUSION	22
3.	IMPROVEMENT OF DATA TRANSMISSION IN FIBER OPTICAL SYSTEMS USING VCSEL BASED ERBIUM DOPED FIBER AMPLIFIER (EDFA).....	23
3.1	PROPOSED SYSTEM.....	23
3.2	VCSEL DESIGN.....	24
3.3	SYSTEM DESIGN	25
3.3.1	Transmission Section Design	25
3.3.2	Channel Section Design.....	25
3.3.3	Receiver Section Design.....	26
3.4	EXPERIMENTAL SETUP.....	26
3.5	RESULTS AND DISCUSSION	28
3.6	DISCUSSION	34
3.7	CONCLUSION	34
4.	CONCLUSION AND FUTURE WORK	36
4.1	CONTRIBUTION SUMMARY	36
4.2	SCOPE OF FUTURE RESEARCH AND SUGGESTIONS	37
	REFERENCES	39

LIST OF FIGURES

	<u>Pages</u>
Figure 1.1: Absorption, spontaneous emission, and stimulated emission process.	5
Figure 1.2: Energy level diagram for different levels in doped fiber amplifier.....	8
Figure 2.1: Common unidirectional topology with lumped amplification.	16
Figure 2.2: An example of a bidirectional fiber connection with contact between Eastern and West (E-W) and West (W-E).	16
Figure 2.3: Optical communication scheme using EDFA Schematic.....	21
Figure 3.1: All optical VCSEL-to-VCSEL wavelength conversion scheme.	27
Figure 3.2: (a) the power output and (b) the tuning of VCSEL wavelengths in accordance to the current distortion[19].	28
Figure 3.3: (a) VCSEL channel changeover and (b) VCSEL wavelength tunability overlap[19].	28
Figure 3.4: VCSEL receiver sensitivity at various bias and drive currents: (a) back to back analysis[33] and (b) 25 km transmission.	31
Figure 3.5: BER sensitivity measurements with 5mA bias and different modulation settings [33].	31
Figure 3.6: Laser extinction at different distances as a drive voltage feature at different points of distance:	32

Figure 3.7: VCSEL LI characteristics..... 33

Figure 3.8: Experimentally measured EDFA output power at 1551.40 nm. 34



LIST OF TABLES

Pages

Table 3.1: Optimized parameters set for VCSEL	25
---	----



LIST OF ABBREVIATIONS

OA	:	Optical Amplifier
SOA	:	Semiconductor Optical Amplifier
EDFA	:	Erbium Doped Fiber Amplifier
XGM	:	Cross Gain Modulation
TDM	:	Time Division Multiplexing
WDM	:	Wavelength Division Multiplexing
Q	:	Quality
VCSEL:		Vertical Cavity Surface Emitting Laser

1. INTRODUCTION

Optical fiber networking networks are commonly used for telecommunication, video, and data transmission across the globe for many years now. Over the last few decades, fiber-optics have made a revolutionary change in commercial telecoms. There is continued exponential increase in demand for transmission via the world telecommunications network, and only fiber optics can meet this challenge. Multimedia optical networks today demand large numbers of information as video services in real time. Currently, almost all existing network trunk lines are fiber optic. This is because it is so large (up to 50 THz) that it enables the transmission of several signals over long distances. An optical fiber with a bandwidth can be used. Be that as it may, the significant lessening forced by the medium is constriction on rapid optical frameworks and systems. It has brought about expanded electronic recovery rates and interest for optical correspondence. Ground-breaking optical intensifiers were accessible which expelled exorbitant transformations from optical to electrical and the other way around. So as to explore propelled correspondence systems, it is essential to examine long and long unrepeated transmission separations and ultraquick broadband correspondence. The feasibility of continuous and ultra-rapid broadband over long distances therefore needs to be investigated. In order to do that, i.e. broadband and repeat less communication via an optical communication device, the optical amplifier must be designed and installed in optical networks.

Erbium Doped Fiber Amplifier receive a lot of attention because it is cost-efficient in comparison to SOA amplifier for long-distance optical communication. The EDFAs have a wide range of benefits, low power consumption, an simple integration with other equipment and are very cost-effective. EDFAs. But because the multi-channel optical system causes saturation problem, it limits system performance.

The focus of this thesis is the use of optical amps in multi-channel multiplexing wavelength division (WDM) all vertical cavity laser (VCSEL) communications system and network with efficient vertical cavity pectoral optics. The objective of this study is to increase optical network transmission size, versatility, and cascades through the optimization of optical amplifiers (EDFAs). The use in cascade by erbium fiber amplifiers (EDFA), It is difficult to accomplish a long transmission separation because of increases in immersion brought about by cross addition (XGM). To utilize the EDFA for WDM transmission long stretch associations, a SOA model is worked in auxiliary enhancement, in light of the investigation of WDM optical correspondence frameworks.

It is along these lines pivotal that the basic boundaries of SOA are advanced so as to diminish the force punishment immersion issue and the bit mistake rate. The simulation of the WDM optical transmission connection with the EDFA cascade is used to optimize this Tool. In order to achieve the correct amplification factor, the ASE effect is also minimized. It has been established that DPSK is very capable of using cascade-based SOA optimization for a duration of 1050 km, compared to OOK.

Containment factor and differential increase was simultaneously optimized to minimize EDFA variation in cross gain for better transmission distances between 40 Gb / s and 80 Gb / s. The soliton RZ-DPSK WDM signals with high limit up to 0,4Tb/s can be effectively moved up to 4550 Km separation with the improved semiconductor optical intensifier with a ghastly effectiveness of 0.4 bits/s/hz.. The XPM study shows that the cross-stage tweaks lessen crosstalk by expanding the transporter life, width and thickness while decreasing the holder factor, the differential addition, and the inclination of the EDFA structure. The EDFA model proves appealing when it uses DPSK WDM as a pre-amp for long distance connections up to 5,250 kilometers for soliton signal signals of 10 to 40 g / s. The results are useable in designing long WDM transmitters with increased capacity over EDFA for low-cost transmission connections.

The placement of EDFA will be examined for the long-distance transmission of the RZ-DPSK signal from WDM and DWDM (dense wavelength division multiplexing). It is shown that the compensation mechanism for post power is superior to the compensation system for pre and symmetrical power. Users can transmit 10 channels on 10 Gb / s up to 68908 kilometers in a transmission distance of up to 100 GHz by using the best period based on post power compensation system. In addition, Apply the same optimal bandwidth to the optimized optical phases modulator. By reducing extremely low ASE-noise (22.3 μ W for 0.1 MW input power), improved ReceiverSensitivity and bandwidth of an EDFA preamplifier model is developed. At the level of the BER floor of 4.6 § bis 10 for the PIN recipient of 10 Gb / s the minimum recipient sensitivity of -69.9 dBm is observed. There was also an improvement in receptor sensitivity of -19.2 dBm and 46.5 dBm in the PIN receptor and DPSK receptor at 40 Gb / s. With the rise in input power and the tolerance to input wavelengths of more than 100 nm, the difference in gain was also observed. In optical alignment and anti-reflection, the EDFA optical reamplifying system is less exposed and eliminates the need for optical filters.

The EDFAs are needed for a larger optical communication system because of the limited bandwidth of the Raman amplifier. We use different approaches to flatten EDFAs without the use

of additional components such as flattening filters, dispersion shifting fibers and regular gratings. Application can be achieved through the combination of two EDFAs, i.e. the first EDFA, for a certain wavelength, with a peak gain, with the same wavelength and the second EDFA. By using EDFA 3rd preamplifier, the total power penalty can be reduced. The overall distance of transmission of up to 490 km can be achieved with gain flattening methods for seventy channels at 40 Gb / s with a channel spacing of 200 GHz.

The Wavelength Converter enhances future optical networks' cascade capabilities. The SOA nonlinearity including four FWM and cross-phase modulation (XPM) wave length converter is used to improve the efficiency of the FWM and XPM based wavelength converter. The improvement of FWM's and XPM 's effects by the SOA structural parameter. The SOA never soaks and upgrades FWM and XPM signals with minor changes to profit. It has been shown that the NRZ-DPSK can be changed over by FWM in SOA in 50 nm all over frequency. For signal-to-siphon proportions of - 5 dB at 50 nm siphons, Q-factors were watched improvement of 1.74 dB at 0 dBm siphon signal. For 10 Gb/s NRZ-DPSK, a 10 Gb/s frequency change of 1302 Km is conceivable through FWM inside the SOA. The SOA-MZ1 wavelength conversion XPM features wide band conversions with upward and downward efficiency of over – 9 dB, i.e. more than 15 nm in length. It is observed that in the SOA configuration, the high active area duration and bias present in the SOA results in XPM. Up to 27 users were served by the bus network topology. Full nodes are more than 29 for ring network topology. Due to the less splicing and missed inclusion into the topology of the star network the number of assisted users can be increased. Tree network topology is evaluated to offer optimized SOAs and optical couplers to the minimum of users. Therefore Tree network topology offered the network metropolitan areas a low cost solution in the presence of optimized SOAs.

This study therefore establishes the optimization by using Vertical Cavity Surface Emitting Laser networks of optical amplifiers for fiber-optical communication leading to an upsurge of the internet traffic to land backbone fiber networks. In addition, by increasing the energy budget or reducing network losses, the number of users and transmission distance can be increased.

The purpose of this thesis was to investigate various methods for increasing the ability of short optical interfaces. The systems focused on modulation of intensity (IM)/direct detection (DD), vertical cavity emitting laser surfaces (VCSEL), and fiber multi-mode (MMF). This thesis consists of an introduction and a collection of original published articles preceded by their summary. The

following introduction briefly describes the topics tackled in the main research papers from the system perspective.

The Technology Revolution needs highly efficient bandwidth infrastructure for multimedia networks. Optical fibers are at present the only delivery means of low-loss communication with such a wide bandwidth. High-capacity fiber communication is the foundation of this information society, a key technology for fulfilling the bandwidth requirements for broadband systems, one of the most rapidly expanding industries since the 1980s. The early optical fiber was diminished by up to 1000 dB / km and cannot be used in fiber optics as an intermediate communication system. Researchers of Corning Glass Works managed to develop a 20 dB / km loss fiber in 1970, which opened doors for contact with optical fibers. Optical fibers with a loss of up to 0.2 dB / km are available for business daily.

The transmission signal is degraded with an increased distance in fiber optic communication. This loss limit can be solved by the use of optoelectronic repeaters. Optical signal is first transformed into electric signal in the optoelectronic repeater and regenerated via the transmitter after amplification. But for wavelength division multiplexing systems, such regeneration becomes quite complex and costly. Therefore, optical amplifiers which directly amplify optical transmitters in order to remove loss limitations without transforming them into electric shapes. Linear amplifiers, optical buffer blocks and optical pre-amplifiers are used in linear mode. Optical amplifiers can also be used as optical doors, pulse shapers and nonlinear routing switches. Optical enhancers, called optical speakers, are utilized for the most part in WDM lightwave frameworks to at the same time extend all channels. Truth be told, the optical amps are straightforward bitrate and can transmit signals at different frequencies all the while. The optical intensifier builds the intensity of the transmitter endless supply of the transmitter. So as to build power, the transmission separation can likewise be expanded by embeddings an enhancer directly before the beneficiary. Not long before the receptor, known as the optical amp, is reached.

1.1 PRINCIPLE OF OPTICAL AMPLIFIERS

In a discrete packet of energy or quantum called photons, the interaction of light and matter occurs. Atom does not exist until it passes from one distinct energy state to another and has a relationship between the greater energy status $2E$ and the lower energy stage $1E$, as shown in figure 1.1. Atom only occurs during certain discrete energy state. Once photonics are present on the atom, The photon, as shown in figure 1,1a, called absorption Because nuclear energy is not immune to energy

state $2E$, the atom returns spontaneously to a lower energy state by releasing a photon as shown in figure (1.1b). It can be excited into higher energy status². Spontaneous emissions are known as. The animated outflow happens when photon with vitality = cooperates with electron in high vitality state and comes back to a low state by making the subsequent photon, as appeared in figure (1.1c), Where the stem steady, c , is light speed and light frequency [Mynbeav, 2003]. As photons and the photons are released in a process and two additional photons are released [Mynbeav and Scheiner, 2003], the light amplification occurs. The continuation of this cycle effectively results in the accumulation of avalanches and the increased coherent emission is achieved.

The higher energy population must be greater than the low energy level. i.e. $2N_1 \gg N_2$ in order to achieve optical amplification, where N_1, N_2 are population densities in the low and upper state. This is referred to as population reversal. This can be achieved by thrilling electrons from external sources known as pumping to higher energies.

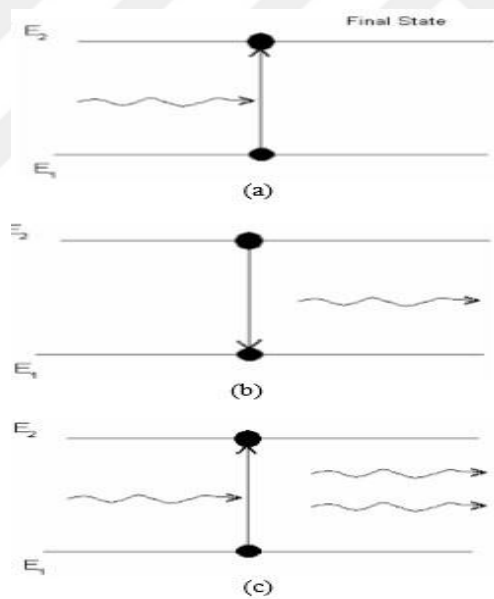

Figure 1.1: Absorption, spontaneous emission, and stimulated emission process.

1.2 TYPES OF OPTICAL AMPLIFIERS

The visual amps are divided into either a linear function (Semiconductor Optical Amplifier, Rare-Earth Doped Fibre Amplifier), or a nonlinear feature (Raman and brilliant amps, by its characteristic features)).

1.2.1 Semiconductor Optical Amplifiers

In order to amplify optical information signals, semiconductor optical amps (SOAs) use the stimulated emission principle. The relationship is significant since the fashion field diameter is 9.3 micrometers and the active area under 10 micrometers. [Mynbeav and Scheiner, 2003]. This is important because of the mode. The injection current provides the external energy to pump the conductive belt element. The input signal stimulates the electron transitions to the valence band and emits photons of the same wavelength and energy than the input signal, thereby producing an amplified optical signal. The SOA is a four part amplifier (FPA) and a travel wave amplifier (TWA) in two different forms. The configuration of the four part amplifier (FPA) is the same as the laser of the maker. This reflects the light coming into the active region from the cleaved face several times and is amplified when the cavity leaves. The moving wave amplifier is an active, reflective-free medium. To improve the input signal via an active region with a single path. In the practical active region, the faces of the semiconductor material have been covered with an anti-reflection coating, the active area is tilt with regard to faces and the tampon is used between active region and facet to decrease the reflexiveness to 10^{-4} [Mahonyet al.,1998].

The stimulating emission can only be dominated if the population reversal is fulfilled. In SOA, the p-type and n-type coating layer are doped so heavily, that the separation of the Fermi level under the frontal p-njunction distance. This condition is achieved by Spontaneous emission levels, emissions stimulated and absorption can be reported as:

Where A, B and B are constants, the number of the photons is the spectrum. In addition, $2N$ is an excited atomic density. According to Boltzmann statistics the atomic densities of thermal balance are distributed [Saleh and Teich, 1991], i.e.

The absolute temperature is Boltzmann, where BK is constant and T. As $1N$ and $2N$ do not vary in thermal balance over time, the rate of transition upwards and downwards must be equal.

1.2.2 Fiber Amplifiers

The Fiber Enhancer also acts as a power amplifier, repetitive and pre-enhancer. The gain medium includes a length of a single-mode fiber linked to the WDM coupler that offers low signal and pump wavelength loss of insertion [Agarwal 2001]. The arousal is caused by the optical pumping laser and the optical input signal inside the connector. In the fiber gain medium, the stimulated emission cycle takes place. The expanded Optical Signal emanates from the other end of the fiber from very wide areas, depending on the form of fiber amplifier such as the Doped rare earth amplifier, Raman fiber amplifier and Brillouin fiber amplifier.

1.2.3 Rare Earth Doped Fiber Amplifier

Various exceptional earthbound particles can be utilized to make fiber enhancers with various frequencies from obviously infrared areas. Erbium dopant in single mode silica-based fibers, known as EDFA (erbium fiber amplifier), is used for the rare earth doped fiber amplifier. An active medium with erbium ions is heavily doped. This is because a large number of erbium ions from several high levels falls into level 2 as illustrated in figure (1.2). Investment in population is stronger. The transformation of erbium ions from level 2 to level 1 would stimulate the transition from optical information through this highly populated erbium doped fiber, generating wavelength, direction and phase photon photon applied [Diagonnet et al., 1993].

The EDFA has three basic elements: longitude of erbium-doped fire, laser pump and narrow wavelength connector for the combined signal and pompe of wavelengths as shown in the Figure (1.3). The pump power and power of the incoming signal, the erbium and the pump wavelength and the optimum fiber length vary accordingly. Owing to the versatility of Erbium doped fiber amplifiers (EDFAs), they are able to be used extensively in optical fiber communication systems. It is low input, low crosstalk, high gain, insensitive to polarization and low noise [Desurvire et al., 1989]. An EDFA has a relatively wide amplification wavelength range that makes it useful for wavelength multiplexing systems as a transmission amplifier. EDFA can theoretically amplify all wavelengths between 1500 and 1600 nm. But there are virtually two wavelength windows. It's the combination of C and L. Band C is 1530 nm to 1560 nm and band L is 1560 nm to 1610 nm. In terms of its efficacy [Giles & Desurvire, 1991] the 980 nm laser pumping source of the semiconductor (above 10 dB increase per mW pump power) and improved noise performance has proved to be the best. The noise level is usually assessed between 4-5 dB and the efficiency between 40-50 percent for forward pumping. Similarly, 6-7 dB and output between 60-70% is the corresponding noise level for backward pumping. The wavelength of the pumping light was 1480 nm. [Yoneda and Okshi, 1992]. However, the population inversion at this wavelength is not high compared to 980 nm. The fluoride doped-phosphate amp is similar to EDFA but has a maximum operating efficiency of 1300 nm with a noise figure of 3-5 dB. Thulium-doped fiber amplifiers provide an expanded optical fiber bandwidth outside the EDFA range. [Kasamatsu et al., 2001].

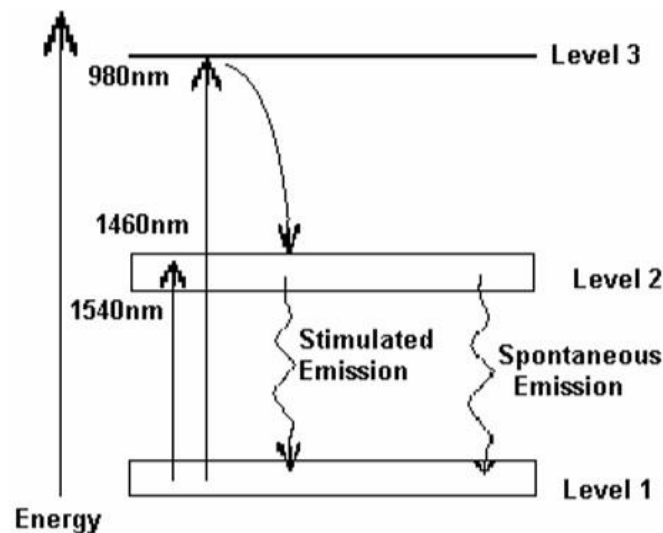

Figure 1.2: Energy level diagram for different levels in doped fiber amplifier.

1.2.4 Raman Amplifier

The Raman optical amplifiers in principle differ in the use of stimulated Raman dispersion (SRS) to generate an optical benefit from EDFAs or conventional laser applications. Silicium molecules that eventuate in an excited vibratory state consume the remaining energy. Here optical phonons participate in scattering process. The principle can also be expressed by taking example of spring that is stretched from to if we put energy into the spring, the entire spring moves. Some energy however scatters. This scattered energy is at a longer wavelength (lower power) which boosts signals at that wave length throughout the fiber. Therefore, if we pump the power at 1450 nm with again of 100 nm, signals at 1550 nm receive a boost in power.

When the pump power transcends a threshold value, the Raman scattering process is stimulated. SRS can be present in the optical fibers in both the forward and reverse direction. Beating the pump in these two directions with dispersed light creates a frequency component at the beat frequencies – a beat frequency that acts as a molecular vibration source. As scattered wave amplitude increases as a result of these oscillations, an appositive feedback loop is established. The Raman benefit depends on the decline period with aroused vibrational state. This rot time is 1 ns for gas or fluid, bringing about a Raman gain band width of 1 GHz. If there should be an occurrence of optical strands the band width surpasses 10 THz.

The population inversion in Raman fiber is shown in Figure (1.4). The spectrum is amorphous because of the widescreen and multipeak nature of the bottle. The frequencies in stocks therefore differ over a wide range from the pump frequency. If Rama's (sp- 1) change is around 13 THz, the highest income occurs. Due to its extremely high bandwidth, SRS is particularly useful. Gain from

Raman is used to offset losses of fiber. Raman amplifiers are simple devices that use silica fiber's intrinsic properties to generate an amplification which makes transmission fiber a distributed amplifier, so the gain in the fiber overcomes signal loss throughout the fiber. Raman amplification is based on Stimulated Raman Scattering (SRS), a nonlinear effect of optical fibers in which a gain of low energy wavelengths is created if the luminous power (approximately 100 nm shorter wavelength) is excited (or pumped up). By selecting the pump wavelength, the position of the gain bandwidth in the wavelength domain is determined. In any area of the transmission windows of the optical transmission network, Raman amplification can be achieved and thus drive a network's efficiency beyond C-band. Over the long-range area, the existing EDFA fiber amplifier and the distributed Raman amplifier (DRAs) may be replaced with EDFAs. With a lower efficient noise level, the DRAs generate wider, flatter gains. These devices also decreased eye closure and increased transient tolerance. Based on the previous advantages, as the next generation of long-haul networks gets financed, DRA transmission will expand. In conjunction with EDFAs, these amplifiers can also be used to remove the number of amplifying sites and regenerators necessary since they work well with EDFAs.

At the point when an exceptional siphon bar engenders it, a fiber-based Raman intensifier utilizes SRS. In one manner, the SRS differs from animated vitality, By discharging its vitality to make another low recurrence photon with decreased vitality, a siphon photon discharges its vitality. In atomic vibrations, optical phonons, the remainder of the vitality is consumed by the medium. This happens when there is a lower wavelength than the amplified signal in a large pump wave. The Raman gain strongly depends on the signal-to-pump pump power and frequency offset. The photon of the pump releases its energy for formation of a new photon at the signal's wavelength plus phonon-absorbed residual energy (vibration energy), as Figure 1.5 shows. Since there are a wide vibrational status over the ground, there are a wide range of possible transitions. In general the gain in Raman is almost linearly increased with the wavelength offset between signal and pump peaking at around 100 nm.

The Raman amplifier generally contains standard single mode optical fiber. Raman's main features are the continuous amplification of the fiber, its two-way nature and stability are more insensitive to reflections [Senior, 1992]. The level of saturation was very high because it depended on the power of the pump [Aoki et al., 1988]. The main drawback of this amplifier is the relatively high demands of pump power compared to SOA and EDFA.

1.2.5 Brillouin Fiber Amplifier

With the exception of the stimulated Brillouin Scattering (SBS) the operating principles of this amplifier are the same as that of the Raman amplifier. This produces signal photons for each pump photon and is used for exciting an acoustic phonon with the remainder of its energy. Amplification only happens if the signal beam propagates in the opposite direction to that of the pump beam. Brillouin spectrum with bandwidth < 100 MHz [Senior, 1992] is extremely small. This amplifier's narrow bandwidth makes it less suitable in light-wave systems as a power amplifier or preamplifier. This amplifier makes the selection of a certain channel by amplified without through other channels in the vicinity .

1.3 PROBLEM STATEMENT

With the growing popularity of bandwidth consuming applications such as cloud computing or online gaming, computation has moved from the distributed devices towards data centers. This puts pressure on the capacity of short-range data center optical interconnects. An interconnect includes a driver circuit, VCSEL, MMF, and a photodiode (PD). High bandwidth multimode 850 nm GaAs VCSELs are typically used in the interconnects to satisfy the high-speed requirement. The capacity of such 850 nm VCSEL–MMF links, defined as bandwidth–distance product, is limited by modal and chromatic dispersion effects. Increasing the speed lowers the achievable transmission distance; conversely, longer links can only operate at lower bitrates. Currently, 10 Gbps VCSELs are used in data centers and they support the optical links up to 300 m [1]. However, with the 25 Gbps optical interconnects becoming available [2,3] the transmission distance becomes limited. The IEEE standard defines 100 m as the 25 Gbps reach. The majority of the existing data center connections are below 100 m [4]. Yet, a solution for an improved link capacity is required to support future interconnect speeds (40 Gbps), increasing data center sizes [5], and already implemented longer links (100m – 300m). Installing parallel lanes is a popular approach. Although viable, this solution is short-term because the optical packaging of components with multiple lanes becomes increasingly complex and there is no sufficient space for the interconnect ports [6]. Moreover, the rewiring is costly and the space in the data centers limited. This work tackles the problem of limited capacity of short-range links by employing solutions that do not require installing additional fibers. We focus on the VCSEL–MMF based solutions because these devices are currently utilized in more than 85% of short-range data center links [7]. The

proposed schemes is based on IM/DD to satisfy the low complexity and energy consumption requirements.

1.4 BANDWIDTH LIMITATIONS

The available modulation bandwidth supported by a VCSEL can be identified through the small signal analysis. VCSEL bandwidth is often given as a 3 dB bandwidth or f_{3dB} is the frequency where the response has decreased to half of its low-frequency value (-3 dB when plotted in the dB scale). VCSEL bandwidth can be limited by intrinsic factors such as thermal effects and damping or by the extrinsic factors [8]. The thermally limited 3 dB bandwidth can be described as [8]:

1.4.1 Bandwidth

A PD's speed depends on the time necessary to transform the incident power into current. It is τ_{in} 's time of rising that electrons and holes reach electric contacts and the time when response rises from 10 % to 90% of the final value is defined. The smaller semiconductor width W , the shorter the travel time, and hence the bigger bandwidth. However, efficiency decreases with the decreasing W , as indicated in Equation 1.17. Consequently, responsivity decreases as well (Equation 1.16). Hence, there is a trade-off between the bandwidth of the PD and its responsivity.

1.5 SELECTION OF STUDY AREA

Determination of the transmission signal with increase distance occurs in the fiber optic communication. By increasing the power budget or by reducing network losses through the use of optoelectronic regenerators the number of users may be increased. The optical signal is initially converted into electric current in opto-electronic regenerators and then regenerated by means of a transmitter. Nonetheless, for wavelength division systems these regenerators are very complicated and expensive. This reduces network reliability in an active device as a regenerator. Upgrading the WDM multi-channel network requires an optical amplifier. The optical amplifiers that amplify the optical signal of the transmitter are specifically used in order to minimize loss limitations and to amplify the signal. The optical amplifiers are mainly used for WDM systems as they can be amplified at the same time by all channels. The transmitter power is increased immediately after and before the optical amplifier.

Since unrepeatable transmission distances over long distances and extremely fast broadband transmission are increasingly required, advanced transmission methods must be examined. This

calls for unrepeated and ultra-highly broadband transmission on long distances of all optical transmission to be studied. It is very important to refine the optical speaker and afterward position it in the optical systems to accomplish these goals, to be specific broadband and rehashed correspondence through an optical correspondence framework.

1.6 OBJECTIVES

In comparison to Erbium Doped Fiber Amplifier (EDFA), Erbium Doped Fip Amplifier (Edfa) received a great deal of coverage in terms of cost-effectiveness. But because of cross-generation modulation (XGM) cross-phase modulation (XPM), the question of saturation gain happens.. and four multi-channel optical system wave mixing limit system performance. The crosstalk and power penalty problem arises in long haul dense wavelength division multiplexing using cascaded SOA due to XGM and XPM. So there is a need for proper placement of EDFA for long haul optical communication systems.

The EDFAs for broadband communication systems are needed because of the limited SOA bandwidth. During the last years, the procurement of optical amps for increasing bit rate and transmission distance was facilitated with different techniques and methods. Capacity and flexibility of the optical networks are the main elements of wavelength converters. The Four Wave Mixes and Nonlinear Effects (XPM) are powerful elements for the wave length efficiency.

All broadcast network topologies show improvement in the number of users in the presence of semiconductor optical amplifiers. But the real model of SOA utilization is not simulated in the literature for low power requirement. This thesis focuses on the investigation of minimizing the nonlinearities in the semiconductor optical amplifiers due to XGM, XPM and gain flattening problems of EDFA for increasing the capacity and flexibility of optical communication networks with the following objectives:

- i.To investigate the optical amplifiers (EDFA) for effective performance with dispersion and fiber nonlinearities.
- ii.To improve the power budget in WDM optical communication network with placement of optimized optical amplifier.
- iii.To investigate placements and other related issues of optical amplifiers in WDM optical communication networks.
- iv.To analyze and compare the different topologies with placement of Optical amplifier in optical communication networks and formulation of topology for optimize performance.

1.7 ORGANIZATION OF THE THESIS

The thesis is organized into five chapters and they are as follows,

Chapter 1: In this chapter an introduction to the proposed research work is carried out. The basic need of EDFA in optical fibers and the roll of its working principles in the optical cables, the gain equalization, gain stabilization and flatness of EDFA are discussed. This chapter also give the information about the dispersion and dispersion compensation in EDFA and the basic concepts of co-doping optical amplifiers with Erbium and Ytterbium.

Chapter 2: In this chapter the literature review is carried out. Major related works in the Erbium doped optical fiber amplifiers with respect to parameters such as gain, noise figure, channel capacity, dispersion, temperature dependence, absorption etc., are studied and reported. Works related to VCSEL optical commination system was presented.

Chapter 3: This chapter gives the description of the works carried with the use of EDFA in the improvement transmission of optical VCSEL communication, presentation of experiment set and result analysis .

Chapter 5: The conclusion part describes the how the performance analysis is carried on Erbium doped optical amplifier here we mainly aim as the recent optical systems require very high power for multichannel system from which the temperature and other non-linearity arise of the direct consequence. In future these effects would be implemented in multi-channel systems with various coding and dispersion schemes to analyze the pattern effects of bits.

2. LITERATURE REVIEW

Koestner and Snitzer[1964] investigated the idea of doping optical fibers with rare earth ions to produce amplifiers. The first fiber amplifiers have been pumped by flashlights and pulsed. In the mid-eighties a rare earth ion deposition technology was developed in single-mode silica fibers, led by D.N.Payne (Payne et al., 1987) from the University of Southampton and the first EDFA was reported in 1987. The SOAs came into existence after generation of lasers in 1962 [Agarwal, 1992]. Both SOAs and Raman amplifiers were developed for practical use in 1980. Light wave systems used optical amplifications for increasing spacing and bit rate repeaters of wave length multiplexing systems in the fourth generation. The use of Erbium doped fiber amplifiers with a spacing between 60-80 kms, and the commercial use of amplifiers until 1990 compensated for fiber losses in most WDM systems. The current emphasis of WDM light wave systems increased the system capacity by amplifying all channels by using single amplifier covering spectral region from 1.45 to 1.62 nm. Bergano et al.[1996] effectively showed transmission of 640 Gb/s more than 7200 km by utilizing a re-coursing circle while Varelle et al. [1999] showed the transmission limit of 340 Gb/s more than 6380 km on a straightline proving ground. The 24,000 km distribution of dispersion-managed solitons was demonstrated by Erwin et al.[2001] at 40 Gb / s. The optical amplifiers have been an important component of almost all fiber-optical communication since 1995. Existing devices must be improved for their high performance.

2.1 INFORMATION AND NOISE IN COMMUNICATION SYSTEMS

In 1948, Claude E. Shannon distributed the thesis, which had become the foundation of the Information Age, entitled "In his paper, Shannon introduced a considerable lot of the crucial thoughts and rules that would later be the hypothetical reason for the advanced way of thinking of logical information. Furthermore, Shannon 's work with the guide of past Hartley's directed to the straightforward scientific relations of the band's reachable channel power, a vitality confined sign harmed by the Gaussian clamor.

$$C = B \log_2 \left(1 + \frac{S}{N} \right) \quad (2.1)$$

In the event that C is the channel limit (bits/sec), B is the channel data transfer capacity (Hz), S is a signal power (W) and N is a complete clamor power (W). Truly, (1,1) for genuinely open blunder free data that can be transmitted over a boisterous channel, the accessible channel transmission capacity and signal to - commotion proportions (S/N or SNR) are constrained. While his

contemporaries assumed that there could be no knowledge on a high enough level,[3] Shannon realized it is still possible to reliably retrieve information hidden deep inside noise at the cost of lower levels of transmission.

This constant equilibrium is observed every day in modern life between information flow and channel noise. The efficiency and speed of data transmission are essentially dictated by capacity / noise compromises. The areas of information theory and communication are in many ways only extensions of the original work of Shannon which explain that the noise in its various forms is the enemy. The communication engineer's main task is therefore to understand how to deal with noise and to maximize the information available on some physical channels (e.g., wireless, copper, optical fiber, etc.).

2.2 DIGITAL DIGITAL PROCESSING AND ASSEMENT OPTICAL DIGITAL.

In this work, the specific aim of the analysis and elimination of the underlying noise processes that limit system performance will be to look to new solutions for better network efficiency and usage. First of all, we shall pay attention to Rayleigh 's role in the bidirectional optical networks in backstream noise (RB). Optimum design of two-way connections will be discussed and various techniques for mitigating RB punishments will be emphasized. In this final part, present developments of all-optical logic will be discussed, The vertical semiconductor cavity (VCSEL) and vertical cavity (VCSSOA) are based on 1550 nm vertical cavity emitting surfaces (VCSEL). All-optical logic is a popular technology for its economic and speed benefits in all optical networks, applications that reach over and beyond fiber optic transmission. When designing the first fully cascadeable VCSEL inverter, at 1550 nm, the effect of optical noise is discussed.

2.2.1 Unidirectional Vs. Bidirectional Systems

In that data can only be fluted one way through a cable, most fibre-optic networks deployed currently are unidirectional. A major benefit of this device type is that back-reflected light signal loss can be avoided with the right optical isolation. The benefit of using isolators in steps of amplification is the removal of amplifiers so that a larger gain can be made per phase [9]. Because of the negligible low backlight, unidirectional systems are mainly restricted to ASE and an NTI. Non-linear and dispersion impairments are correctly addressed (see Figure 2.1). Nonetheless, unidirectional systems have a downside of using a different fiber wiring or a different wavelength spectrum (for the same cable) in the full duplex communication. Bidirectional communication via a single wavelength and a single fiber is the priority from the point of view of hardware

performance, latency, network integrity and network management. For two-way signaling, the total fiber data output can be doubled by upstream and downstream traffic at the same wavelength.

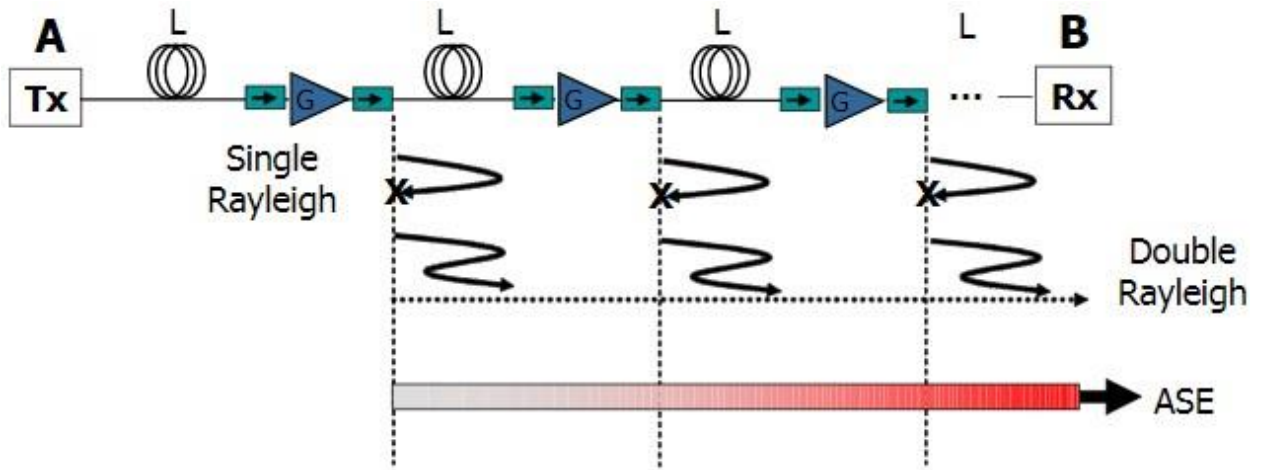

Figure 2.1: Common unidirectional topology with lumped amplification.

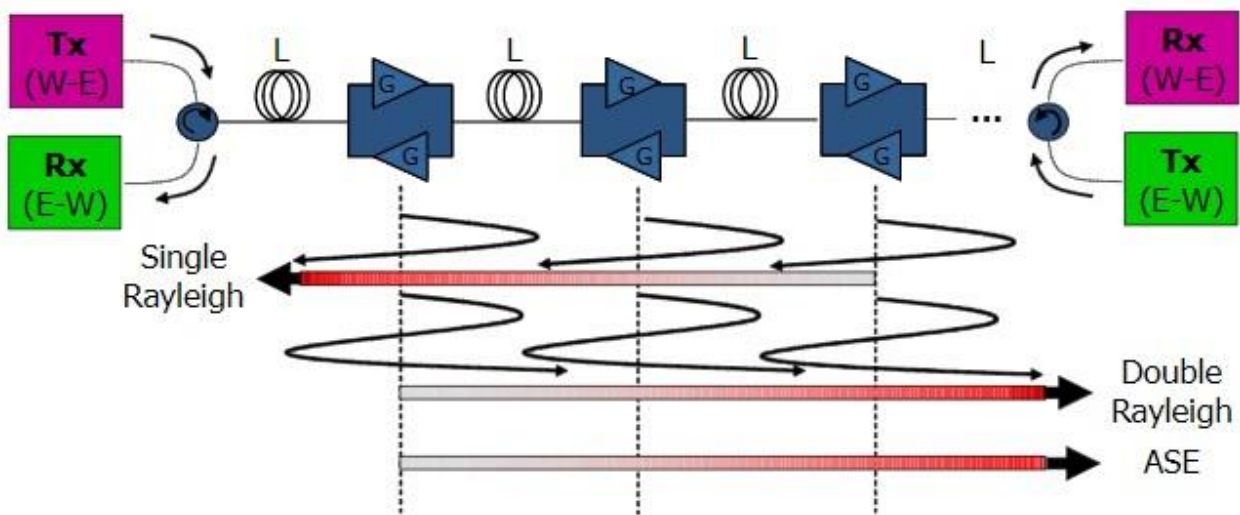

Figure 2.2: An example of a bidirectional fiber connection with contact between Eastern and West (E-W) and West (W-E).

2.2.2 All-Optical Systems

The ability to supply optical digital signal processing (DSP) in optical data streams is a long-term innovation of photonic systems. Optical DSP is a crucial component of future optical communication systems with full memory applications, optical routing, and optical computing. The electronic domain currently needs to perform network functions including signal routing and

data buffering. It is efficient but impedes latency, bandwidth, and energy consumption because signal conversion requirements are optical electric-optical This electrical solution. Potential optical networks are commonly believed to replace expensive OEO knots with ODSP capability with photonic technologies.

While there are a range of techniques that are optical DSP, due to various limitations in cascades, speed, energy, dimensions, specific integrability and cost of logical elements, no consistent technology framework has emerged. Recently, because of their small scale, high nonlinearity and strong 2D integration capacity, VCISOAs gained considerable attention for these applications. Sadly, the major focus was on 850 nm wavelength band applications. Because of the more complex development of 1550 nm VCSELs, research on the main telecommunications band is still in progress in VCISOA. In the case of noise, DSP relies on various portals in their capacity to restore logic in order to cascade several logic elements successfully (i.e. Boolean gates),. The integrity of the digital system with noise is known as immunity to noise and depends on the transmitting function of the individual gates (TC) to a nonlinear input and output characteristic and the ability to regenerate logic levels [19, 20]. This thesis will discuss recent work in the area of VCISOA 1550 nm. A cascaded inverter will be demonstrated up to 2.5Gb / s with sufficient noise margins and logic regeneration.

2.2.3 Non linearities in Optical Amplifier

The optical amplifier contains too many nonlinear effects that limit the bandwidth output of the optical amplifier to different applications in optical communication systems. In optical amplifiers there are nonlinearities such as saturation gain, 4 wave mixing, modulation of cross gain and phase noises affecting the optical communication system.

2.2.3.1 Gain saturation

If the voltage is too high, the recovery coefficient tends to decrease, thereby reducing the signal power. By increasing the active area time of SOA, the signal is increased. This effect includes all electrons from the conductive ribbon, due to its high optical power, which does not stimulate a further transition to valence band by further growth in the number of external photons. Therefore, there are no further stimulated photons. When the SOA gain is reduced, g is compared to SOA P Saturation.

$$g = \frac{g_0}{1 + \frac{P}{P_{sat}}} \quad (2.2)$$

2.2.3.2 Four wave mixing and cross gain modulation

In WDM networks, several channels simplify simultaneously so that the crosstalk may take place between the channels. Two types of crosstalk occur in SOAs; Cross-saturation and inter-channel. When two adjacent channels enter the SOA, inter-channel crosstalk occurs. A non-linear interference produces new signals at beats and amplifies them more than the original signal. This effect is known as a 4-wave SOA mix. Cross Saturation occurs if SOA works, and the channels change from ON to OFF in saturation mode. This is called Cross-Gain SOA (XGM) Cross gain. This gain change leads to changes in signal amplification, given that all signals are generated by the same gain from an active media. This change depends on the gain rate after the input bit rate. For SOAs, the lifespan is approximately 1 ns. Every bit rate below 1 Gb / s causes serious crosstalk [Mynbeav and Scheiner, 2003]. While in EDFA it is not important that the crosstalk is about 10 ms because the carrier life is about 100 kHz. In order to reduce the SOA crosstalk, saturation power should be increased and the carriers' lives decreased. The RZ differential stage shift (DPSK) modulation in mathematics has attractive research interests [Xuet al., 2003] since the signal power for this format is constant, and the WDM transmission link based on SOA is applied to this format because the cross-gain (XGM) effect is reduced accordingly. Saturated SOA [Zho et al . , 2002] undermines noise resistance in spectrum-sectioned WDM systems. Through rising the saturated SOA bias current , high noise reduction and high bandwidth have been achieved. Intensity / noise reduction system rise of 13,5 dB at bitrate 2 488 Gb/s was achieved for the optimal operation of the SOA.

2.2.3.3 Polarization sensitivity of SOA

The gain of the SOA is polarization dependent due to the rectangular shape and crystal structure of the active region. The gain of SOA was varied from 5 to 7 dB due to polarization [Agarwal, 1992]. Olsson et al. [1987] investigated to reduce the polarization dependence in the SOA. It was required to make active region square in cross section, connecting two SOAs in series or in parallel to compensate for the orthogonal polarization unequal gain. A double pass of signal through the same active region was also reducing the polarization dependent gain. Hence, polarization dependent gain was reduced to 0.5 dB for the SOA. The optical amplifier magnifies the signal noise along with the signal and also generates its own noise. The noise figure for the SOA was 6 to 9dB [Agarwal, 2001].

2.2.3.4 Phase noises of SOA

In the SOA medium the intensity variations of an optical signal change the SOA's refractive index. This change in the refractive index results in a non-linear phase shift, resulting in self-phase modulation (SPM). The phase noise effects are lower at higher bit rates reported by Wei et al. [2005]. They proposed that saturated induced SPM could be substantially reduced by increasing the SOA bit rate and carrier life for DPSK one-channel signal enhancement. This is known as cross-phase modulation (XPM), a phenomenon in which variations of the intensities of an optical signal can change the refractive index of the SOAs and modulate the stage of other optical signals spreading in the same SOAs. In previous SOA literature this effect was not addressed. EDFA optical noise is called ASE (spontaneous amplitude). The actual signal degradation occurred because of a beating signal caused by noise and noise. [Mynbeav and Scheiner, 2003]. The noise-to-noise beating can be removed by using narrow band filter. The noise is also higher for counter propagating pump system. The splicing loss occurs due to the mismatch of core diameter of single mode fiber i.e. 8 and 10 μm and the core diameter of erbium doped fiber varies i.e. 2.8 to 5.2 μm [Senior, 1992]. The noise figure for the EDFA was 3.5 to 9 dB less than that of the SOA. There are several techniques used to flatten the gain of EDFA.

2.2.4 Gain-Bandwidth of Optical Amplifier

For transportation of multi-media information signals, the bandwidth result of the optical amplifier must be broad. The FPA shows peak gain called resonance gain and gain can be improved by increasing its reflection. For FPA, reflectance up to a reasonable limit may be increased. When $R=0$ is in the FPA, the amplifier gain will be TWA gain. In order to achieve high gains in the TWA, an active region had to be long enough. Thus in the TWA there is a saturation gain issue. The FPA has a small bandwidth but a large profit. The bandwidth of the TWA is greater but less. The FPA's bandwidth was 0.0086 nm and the TWA's bandwidth 40 nm [Mynbeav and Scheiner, 2003]. Compared with the TWA structure, the FPA construction is also complex and expensive. Jenne et al. [1997] developed the SOA model, which provided detailed results for single-channel and low-saturated transmission. SOA used was noted by Jenne et al. [2001] as the minimum signal gain was 12 dB, 10 dB of noise, and 12 dBm of SOA. The experimental arrangement of Bjorlin and Brower [2002] showed that the noise level has been strongly affected by the mirror reflectivity. By choosing the right mirror reflectivity's, the spontaneous beat-noise in signal enhancement)) ((can be eliminated. The highest P(saturation power) of the reported SOAs is + 17 dBm for the single polarizer [Dagenais et al. 2003]. SOA can also be used to relay small numbers of channels.

The fiber amplifiers for broadband optic communication systems are used due to the limited SOA bandwidth. Doped fibre amp, which work in wavelength ranges close to 1.55 μm , have the minimum fiber diming in this region [Agarwal 2001]. The doped fibre amplifiers are very attractive. The EDFA simultaneously extended both channels when a WDM signal was amplified. The amorphous source of silica has influenced the form of the profit spectrum and included core fibers such as Germania and Alumina. The EDFA has a wide core range with Germania and a double-peak structure [Pedersonet al . , 1991]. Their core is focused on Germania. Typically, EDFA gains more than 35 nm in bandwidth. The increase from EDFA varies from around 20 to 40 DB depending on how they operate as a booster or an amplifier, as reported by Diagonnetet, and the number of pumps and core radius of the EDFA is dependent on the concentration and length of the enhancement amplifier and the pumping capacity. al. [1993]. The Raman amplifier showed benefits of self-phasing and a wide range of gain bands between a pump and an optical signal. Aokietal al. [1988] investigated the 20-dB increase in Raman silica fiber by using suitable fiber doping with a wide spectral bandwidth up to 40 nm.

2.2.4.1 Gain flattening

The gain depends on the wavelength and the range of radiating energy bands is limited. Actually gain curve fluctuates between 1530 and 1560 i.e. there are two peaks at these frequencies and hence is highly undesirable. We should have a flat gain for the range of operating wave length i.e. 1530-1560 nm and 1560-1610 nm. This property of EDFA amplifier is called gain flatness. Various filters are designed to flatten the gain in these ranges.

The gain clamping is the fixed drop in gain from fluctuating gain to achieve stable gain. Giuliani and Alessandro [2000] proposed gain clamped SOA which offered advantages over the conventional SOA. They found that the response of the SOA was linear and suffer less from crosstalk related effects. Gain clamping was achieved by fabricating two distributed Bragg (DBP) mirrors on both ends of the amplifier [Wolfsonet al., 1998;Giuliani and Alessandro, 2000]. For the SOA in TWA fashion, reflections must be avoided which leads to an implementation with angle strip and facet antireflection coating[Kellyet al., 2000].

Bononi and Barbieri [1999] designed a gain-clamped DFA (distributed fiber amplifier) Power selection, laser wavelength and loss of laser cavity with different WDM signal numbers, per channel power and gain. For WDM transmissions of eight channels, 12 dB for input signal power per channel was required, using gain clamped DFA. It was found that a 21.5 dBm pump power and a 1530 nm laser ensured less than 0.25 dB of the worst shot case.

Cockrane et al. [1990] noted in the EDFA that the gain was the function of wave length and two-fold gain fluctuates at 1530 and 1560 nm . The EDFA gain was flattened by using various methods to obtain good gain bandwidth product. [Wysocki et al., 1997]. The notch filter was used to flattening of gain over wavelength with length of active fiber ranging from 20 to 50 meters as optimal length. The gain also depends upon the pumping power for population inversion. A noise figure of 3.2 dB in 30 m EDFA was calculated and pumped at 0.98 nm at 11 mW of power [Ono et al., 1999]. In two stages, the EDFA amplifier was cascaded, achieving a flat increase of 0.5 dB at 1544-1561 nm wavelength.. Ono et al. [1999] demonstrated the gain flattening technique by using passive filter-based method.

Zimmerman and Spiekman [2004] studied various methods for gain flattening such as Alcodoped hybrids and Al / P codoped AFFA, Raman Hybrid and EDFAs with the help of amplifier gain simulation. They found the use of equalizer filters to increase the EDFAs was the most useful technique, although the hybrid Raman amplifier and EDFAs had maximum bandwidth accessible without any energy consumption in the optical filter. Therefore the SOA must be optimised to decrease amplified random noise intensity and increase saturation for better access and bandwidth in optical communications.

2.3 BASIC PRINCIPLE OF EDFA

The optical amplifiers are the Doped Fiber Amplifiers (DFAs), which always use the optical fiber as a means of enhancing an optical signal. The most commonly used amp is the EDFA, which dopes the central part of the silica fiber with trivalent erbium ions and can be skillfully pumped with a 980 nm or 1,480 nm laser wavelength and shows an advantage in 1,550 nm regions.

A comparatively high-powered light beam is coupled to the input signal with a narrow wavelength interconnector in the schematic of optical communication used for EDFA. There, the input signal and the arousal light are of very different wavelengths. Figure 2.3 shows the schematic of optical communication system which employs EDF as amplifier.

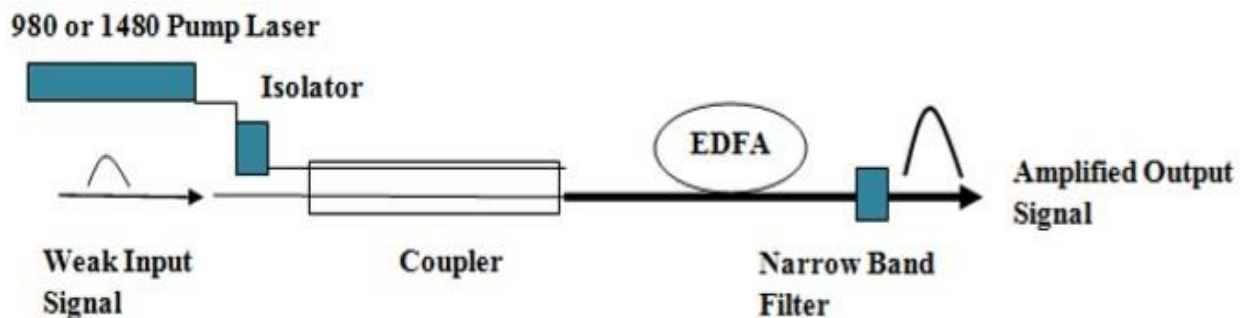

Figure 2.3: Optical communication scheme using EDFA Schematic.

In a fiber section, a combined light is introduced in the central section with erbium ions. The relatively highly powered luminous beam causes erbium ions to move towards their higher energy status. At varying wavelengths from the pump light, photons which form part of the signal are confronted with the excited erbium atoms. The erbium atoms thus lose energy in the signal and go back to their previous low energy status. It is important to note that the erbium loses energy in the form of extra photons in the same phase and direction as the amplified signal. The signal is therefore only increased to its range of navigation. When an atom "loasts," it normally shares the energy with the incoming light in the same direction. The entire power of the signal is shifted along with the input signal. In the output, the reflexes of the attached fiber are normally equipped with an insulator. Relative reflections interfere with the amp function and enhance the laser amplifier. An amp with high gain is an erbium-doped amplifier. EDFAs in Wavelength Multiplexing (WDM) systems are considered essential segments due to their smooth qualities: insensitivity to polarization, high gain, immunity to crosstalk (Yusoff et al. 2012).

2.4 CONCLUSION

Here, it can be justified that EDFA's have been an interesting and active area of research in the field of Optical Communications. EDFA's can be used for long-distance data transmission due to their wide band and optimized bit error rates. The benefit of DWDM technology is that a single erbium doped fiber amplifier for all channels can easily receive and amplify the signal and is convenient to transmit in core networks. Therefore, fiber loss is a fundamental limitation for long-haul points of fiber communications and fiber optic systems. Moreover, the optical power loss resulting from dispersion and absorption mechanism in optical fiber is the other major limitation on the transmission distance.

3. IMPROVEMENT OF DATA TRANSMISSION IN FIBER OPTICAL SYSTEMS USING VCSEL BASED ERBIUM DOPED FIBER AMPLIFIER (EDFA)

Vertical Cavity Surface Laser Emission system (VCSEL) is establishing a new age of high-speed error free long-distance data transmission. The device based on Edge Emitting Laser (EEL) [1011] is well ahead of the temperature dependence and the transmission capability at high speeds with relatively high output power generation. For VCSEL based network, Free data transfer was also a big obstacle for long-range errors. This system is also increasingly challenging to meet the growing demand for high-speed communication. Several research projects seek to achieve a BER and an improving VCSEL-based system performance for high-speed long-range signal transmission. In the VCSEL system fiber amplifiers are used because they provide all optical amplification which reduces the need for electric components. In a range from 25Gb / s[12-12] to 50Gb / s[14] at frequencies near infrared wavelength, High output [15], for example , higher temperature and error free operation can be achieved with VCSELS near the red wavelength. A variety of special advantages come from VCMEs. VCSEL driver ICs [16], self-heating control for several experiments [19], infrarouge VCSEL [18] temperature analysis, thermal effect of VCSEL [13] gain guide modeling and space hole burning[20] have been reported to be more efficient as a transmitter VCSEL transmitter is reported by red VCSEL (680 nm) with a sustainable temperature up to 105oC and 14mW power generator [21].

3.1 PROPOSED SYSTEM

This study proposes that data sharing from end-users will use the same wave-length allocation as the all-optical reuse technology using the VCSEL (Vertical Laser Emission Surface) costeffectiveness. For directly modulated 10Gb / s data from the input downstream wavelength, the saturated optical erbium fiber (EDFA) amplifier is used. We show that the wavelength extinguishes with EDFA saturation to less than 1 dBm to remodify the wavelength. For downstream and upstream data signals, a recipient sensitivity of -19.65 dBm and -17.86 dBm is achieved. A powerful 24,7 km transmission in single-mode fibers. This technology opens new opportunities for efficient use of spectrum with non-static flex spectrum grids for wavelength applications in flexible optical networks.

In this work, we propose a wavelength reuse technique employing the use of erbium-doped optical fiber amplifier (EDFA) operated near saturation and clamped with a holding beam to limit the variance in the total input optical power. Our proposed technique is all-optical, in complex and for implementation purposes, it does not require any customized components.

Figure 3.1 displays the complete experimental configuration of this study. With a 10 Gbit / s data signal a single VCSEL carriage mode of 1 550 nm was modulated directly. The power output was then directed to a 4-circulator port 1 with the length 24.7 km for downstream transmission via SSMF. This is a typical transmission distance for the PON network. At the end of the patient an optical signal for demodulation was effectively guided by a second circulatory device. The optical power input was linked to the second circulator 's port as shown. The result was a port 3 splitter, which was used at the port to separate the optical input to simultaneously analyze the downstream and remodeled connection. A variable optical attenuator has an output in the optical splitter, the photodiode and the downstream connection performance is analyzed by the measurements and analysis of the eye diagram by bit error ratio (BER).

Since its aim was to design an ultra-high-speed data transmission system based on VCSEL (BER < 10⁻¹²), and to analyze the performance in room temperature, a VCSEL-based system with a distance of 0.6Tb / s was first demonstrated. The output power, quality factor and the system bit error rate at wavelengths of 683 nm, 863 nm, 1550 nm are then analyzed at ambient temperature. The focus was on creating the red and infrared wavelength VCSEL-based system (first and third windows), which was why choosing those wavelengths played an essential part. The performance analysis was also performed here on the output power of both modulated RZ and VCSEL modulated NRZ. Finally, the maximum bit-rate operation is achieved by the room temperature system based on 863 nm VCSEL and the performance by all existing room temperature VCSEL systems is far exceeding [22].

3.2 VCSEL DESIGN

Opti System Technology is used for VCSEL architecture and device performance analysis.

VCSEL of 863 nm was used to build error free data transmission which is listed below.

Table 3.1: Optimized parameters set for VCSEL

Parameters	Value
Thermal Impedance	2600C/W
Thermal Time Constant	1E-6
Scaling Factor	2.6E-8W
Gain coefficient	16000s ⁻¹
Carrier number of transparency	19400000
Carrier lifetime	1E-9s
Photon lifetime	3E-12s
Spontaneous emission factor	3E-5
Max. Input current	40mA
Bias current	5mA
Modulation peak current	10mA
Injection efficiency	1
a- $I_{off}(T)$	1.25e-3 -2.55e-5 2.91e-7 -2.53e-10 1.02e-12
b- $V(T)$	1
c- $V(I)$	1.721 275 -2.44e4 1.34e6 -4.15e7 6.68e8 - 4.27e9

3.3 SYSTEM DESIGN

This VCSEL-based system is built in the presence of EDFA and SOA for the transmission of error-free data at 50 km. Our proposed program is a three-part combination.

3.3.1 Transmission Section Design

683 nm is used for the system output analyze at room temperature in the transmission segment RZ, modulated VCSEL of 1550 nm, 863 nm. VCSEL is powered by a bias generator that ensures adequate stability and reduces non-linear influence. This model generates digital data with a pseudo random bit sequence (PRBS). A 6dB extinction ratio Mach-Zehnder modulator mixes an electric signal with the input to generate the output optical signal. Easy mode optical fiber connects the output signal.

3.3.2 Channel Section Design

In the channel portion of the layout a single 50 km optical fiber was used. The optical fiber has a 16.75ps per nm / km dispersion and a 0.2dB / km diminution. Optical amplifiers (EDFA) for less noisy and improved output efficiency at wavelengths are used..

3.3.3 Receiver Section Design

An optical sensor is utilized to gather information from the transmitter segment in the beneficiary area. An APD photograph indicator and a low pass channel are given to the optical recipient. The picture identifier gets the information and transmits it to a low-pass channel to dispose of high recurrence signals. Considering the impact of the shot, warm commotion and receptor clamor on the gadgets accepting end.

3.4 EXPERIMENTAL SETUP

The interference with wavelength has a detrimental impact on the usage of resources in versatile optical spectre networks as it limits the amount of wavelength bands in the spectrum bandwidth available. WDM systems have presented various wavelength conversion techniques to minimize this effect effectively without adding extra bandwidths. A wavelength conversion technique for the transmission at low attenuation 1550 nm of a fan was experimentally demonstrated by the Nelson Mandela University Broadband Communications Group. The technique was further studied and used to test all optics for spectrally effective injection by defragmentation and wavelening The Center for broadband communication at the Nelson Mandela University. The operation of the transmission in routing nodes and the wavelength allocation in versatile multimode networks was further investigated, as shown in Figure 3.1.

A solitary mode VCSEL1 with a frequency scope of 5.2 nm at 8.5 Gbps was balanced with a non-come back to zero (NRZ) pseudo-random paired succession (PRBS 27–1) from a programmable example generator (PPG). The tweak conditions were altered with the PPG to fit the force supplies wanted. The ace laser was embedded optically into the side mode at a similar frequency of VCSEL 2 and 9.5 mA current with an intensity of -4.49 dBm at 5 mA and a 5 mA drive current with a working intensity of -3 dBm at 1548,2, nm at 1550, 3 m at 3 dBm. A fiber doped erbium intensification (EDFA) was utilized to build infusion power by intensifying the yield intensity of the ace laser to give adequately immersion in the laser depression of VCSEL 2.

The 2 dBm optical power injection wavelength conversion was considered. A 10/90 coupler was used for accurate power monitoring, with 90% of optical power being injected directly to slave VCSEL 2 slave 1548.20 nm side mode via Port2 in circulation and 10% monitoring using a power meter. A transduced VCSEL 2 data signal (node 2) is transmitted via port 3 through alloptical injection routing and wavelength assignment to transmit the optical fiber G.655 over 25 km. The objective (hub 3) comprises of a variable optical attenuator (VOA) that can construct the setup for

power misfortunes for different fibro-light rezipie tracks (consistently 19 dBm at a 10–8BER edge) and an electrical enhancer (EA). The termination proportion (ER) and affectability of the beneficiary were estimated with the Bit Error Tester (BERT) to assess information quality and the transformed information signal for the balance estimated as Bit Error Rate (BER) and the eye charts. Examination of the necessary force distinction somewhere in the range of "1" and "0" paces of the optical recipient will compute proper transmission punishments for a given framework. This is driven by an optical power trade off, end extent and overshooting modification in eye diagrams. The overwhelming is because of the adjustment in the dynamic laser, as "0," preceding lasing, approaches the limit. A major contrast between the force levels is required for improved piece blunder rate execution (great assistance quality). The force proportion is '1' and '0;' when the force punishment blunders have diminished, the framework will flood with a serious extent of termination. A fiber trial of 25 km G.655 was utilized to improve the framework and to break down the impact of light pathways on framework execution.

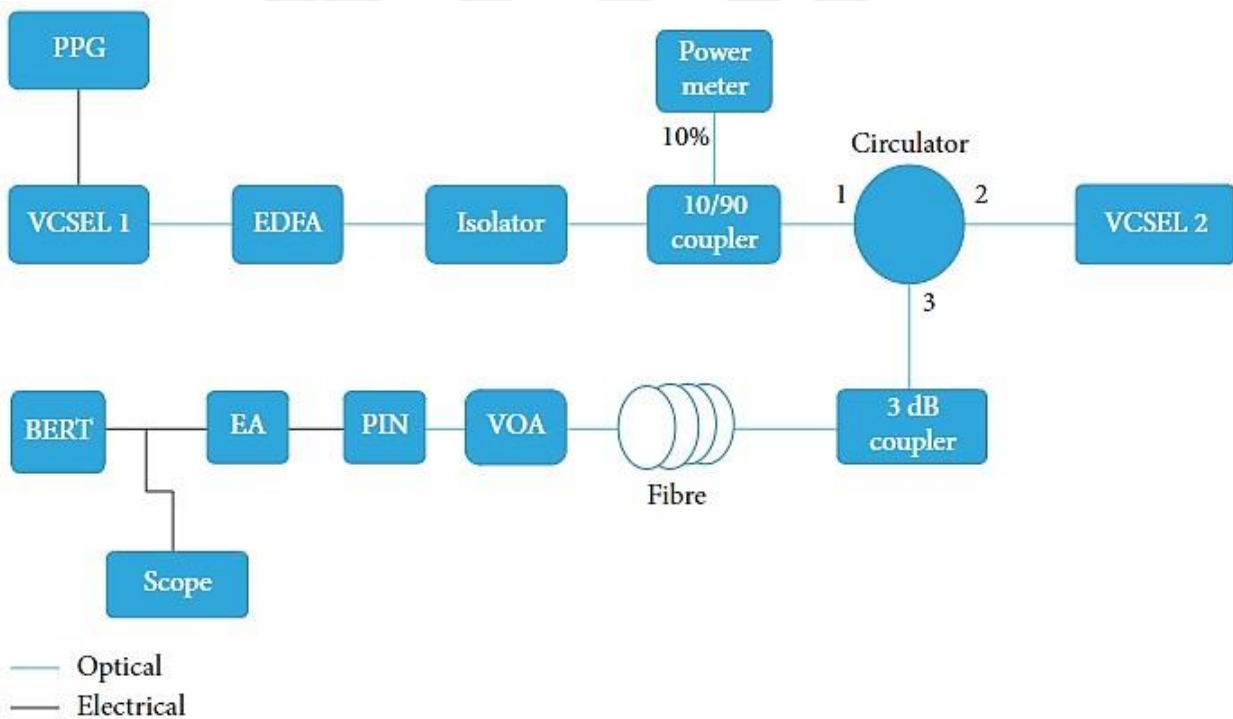

Figure 3.1: All optical VCSEL-to-VCSEL wavelength conversion scheme.

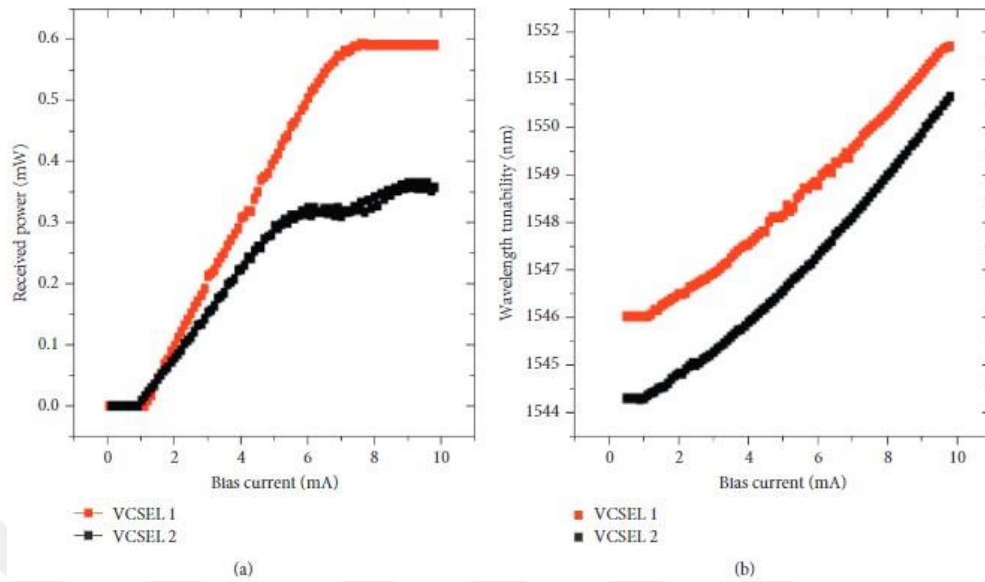

Figure 3.2: (a) the power output and (b) the tuning of VCSEL wavelengths in accordance to the current distortion[19].

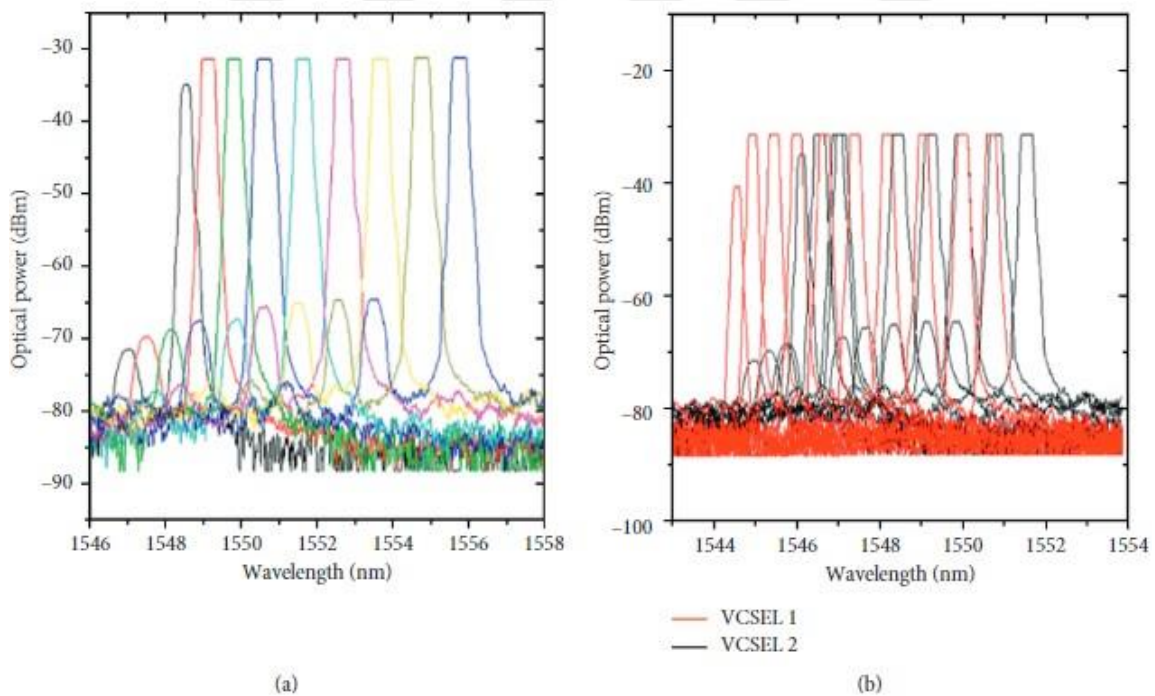

Figure 3.3: (a) VCSEL channel changeover and (b) VCSEL wavelength tunability overlap[19].

3.5 RESULTS AND DISCUSSION

The sensitivity for receiver was measured and evaluated for the master laser (VCSEL 1 depending on bending current and drive current) in order to calculate the transmission power penalty for the

device. In a B2B reverse (VCSEL) configuration and a transmission 25 km through G.655 optical fiber, the effects of the signal impairs light traffic. were studied. The area of excellent service quality (receiver sensitivity) can be identified as a field of 3D surfaces, as shown in Figure 3.4, depending on the signal carrier bias current and modulation conditions (discursive current) of all data being transferred.

The laser has a direct optical force and a predisposition current relationship for bends after and before the immersion edge. This is the safe working arrangement of VCSEL. In this technique, a specific number of potential inclinations and current drive blends assessed the affectability of the beneficiary, creating a space as a 3D surface guide that can be applied to investigation framework results, as appeared in Figure 3.4(a). The best beneficiary affectability was serving for inclination focuses inside the range 5–7 mA and for balance in the range 4–7 mA drive current. Good power ratios of "1" and "0" were achieved with a limiting VCSEL chirp and consequently low penalties. On the transmission of 25 km, the domain of the sensitivity sensor of the 3D color receiver is the same as the domain shown in figure 3.4(b). There is no error-free transmission on the extremities and the surface can be used for a specified network region to measure the transmission penalty; the optimization technique was therefore experimentally demonstrated successfully.

The drive current should be just above the threshold for VCSEL, for which the ideal signal is produced, when the VCSEL begins to lash and just below the power saturation of the output (roller). Figure 7 shows the results at 5 mA applied distances while 1 mA increments of 1 mA to 6 mA differ with modulation drive present. There was an error level at drive currents above 6 mA and a 10-9 BER due to the chirp has not been achieved. The optimum modulation conditions for the given VCSEL are seen as 5 mA bias and 5 mA power supply with – 16,41 dBm receptor sensitivity, as shown in Figure 3.4. The perfect modulative environment for routing and wavelength selection was selected, based on the appropriate service quality (acceptable receiversensitive system) for improperly transmitted transmission based on the data 10-9 BER data and the (inverse) threshold converted to Figure 3.5).

Sensitivity to VCSEL 1–9,19 dBm for the transmission back-to - back had been measured and– 11,39 dBm was measured for the 25 transmission, resulting in a penalty of 2.2 dB. At the threshold during a VCSEL 2 all-optical injection, the inverted carrier displayed a responsive reverse to back transmission – 18,71 and no faults for inverted data transportation of 25 km. In VCSEL 1 without conversion and reversal, the eye is open, which allows the receiver to differentiate between the levels from 0 and from 1 and achieves an extinguishment rate of 9,136 dB. The eye was blurred

and the extinction ratio decreased to 8,034 dB with 25 km transmission. With inverted back-to-back data from VCSEL 2, overflow rates above 1 level with obtained 5,012 dB ER are not discernible at the recipient end and therefore affect the system performance. The eye was extremely distorted after 25 km of transmission and shut with the extinction ratio down to 2854 dB as illustrated in Figure 8(b), so error-free transmission, regardless of high receptor sensitivities, can not be achieved. The extinction ratio can therefore be used as optimization technology; it has thus also been used to analyze the VCSEL performing quality in both back-to-bacco data and the 25 km transmission of the eye diagrams, as illustrated in Figure3.5.

In Figure 3.5(a), the domain of the surface area 3D color extinction ratio reflects that the VCSEL may operate safely within a limited range of potential biases and driving currents. Over the extreme points of the lasing threshold the operating system damages. A high current drive contributes to a high risk of extinction. At a low current, the eye is open, which makes it easier for the receiver to differentiate between 0 and 1. Thus power levels at the receiver end are not discernible, thus impacting system performance. The eye is open with an output current of 5 mA, and the extinction ratio is small, So the modulation specifications for the system are fine. As shown in the figure 3.5(b), in 25 km of reduced area transmission the surface map domain will remain the same. 3Dcolor Extinguishing Ratio. In the implementation of versatile bandwidth multi-mode networks, an efficient Optical Performance Monitoring Approach has been experimentally shown to optimize light paths based on the known deficiencies.

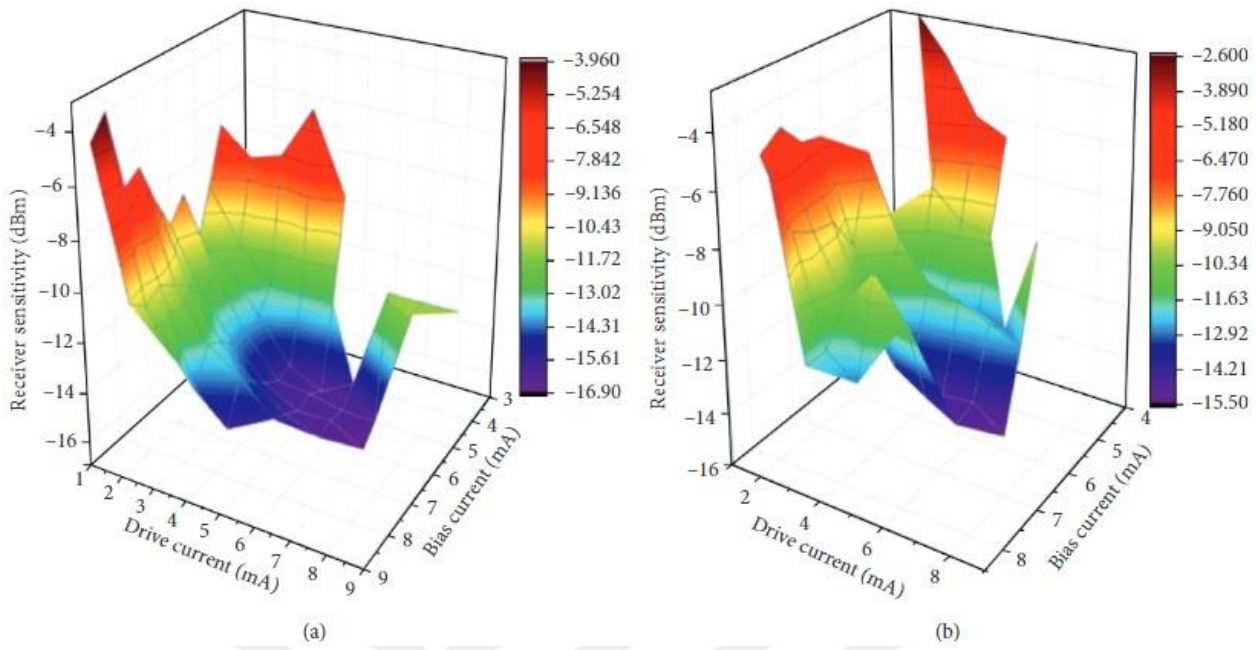

Figure 3.4: VCSEL receiver sensitivity at various biases and drive currents: (a) back to back analysis[33] and (b) 25 km transmission.

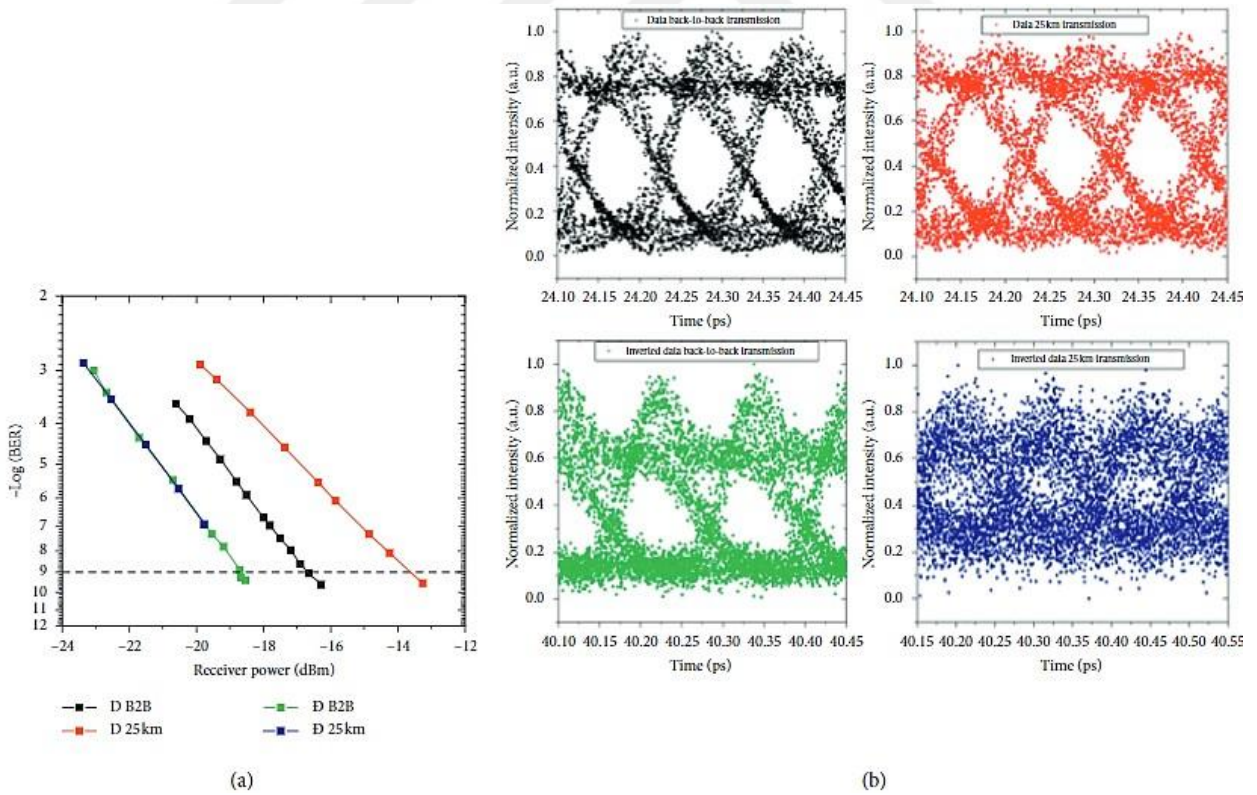

Figure 3.5: BER sensitivity measurements with 5mA bias and different modulation settings [33].

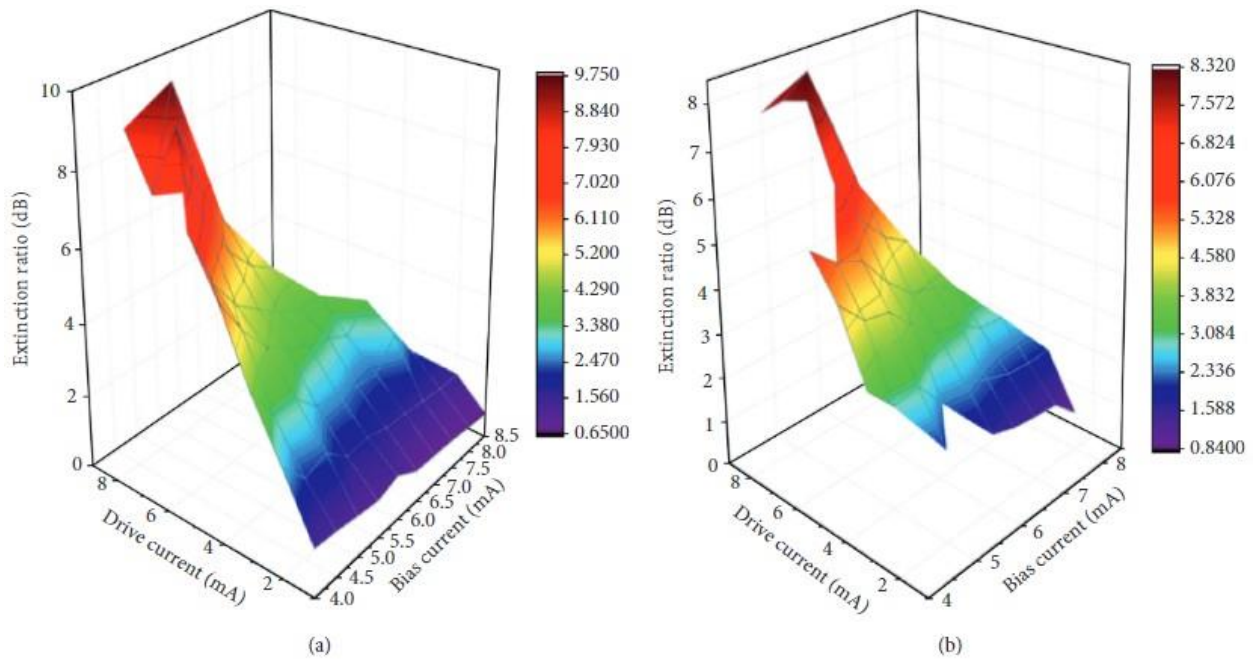

Figure 3.6: Laser extinction at different distances as a drive voltage feature at different points of distance:

(a) transmission back-to - back [33] and (b) 25 km transmission.

The static execution of the VCSEL transporter is appeared in Figure 3.7 tentatively determined and mimicked. During the account of the individual yield optical force the exploratory outcomes were accomplished by shifting the inclination current for the VCSEL from 0 mA to 9.8 mA. As appeared in Figure 3.7, the current was under 10 mA. At 5.52 mA in this work was the VCSEL bearer. The ideal direct regulation with the information signals was given by the best ER.

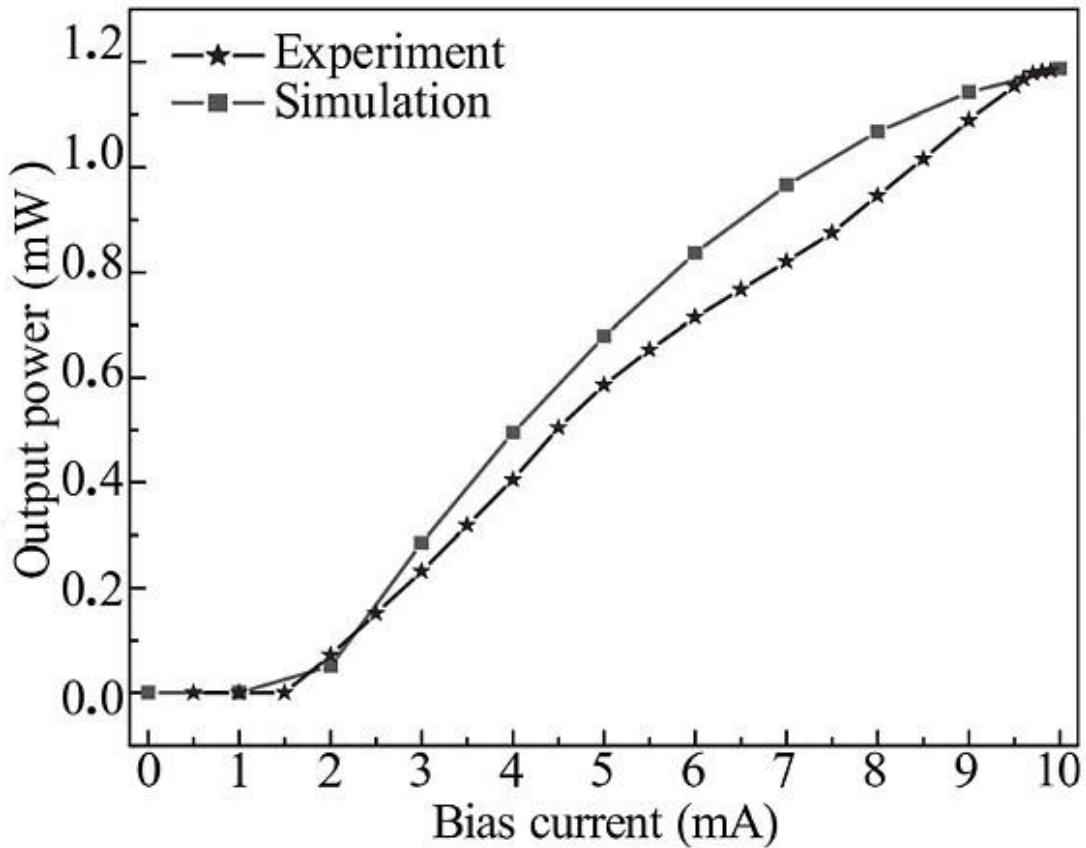

Figure 3.7: VCSEL LI characteristics

Using EDFA with gain saturation to remove all wavelength reuse optical data after 24.7 km transmission downstream, is recommended. Figure 3.8 shows that related to the info optical intensity of the utilized EDFA the yield optical force properties of EDFA is determined. At a low optical information power , the yield properties of EDFA were straight. Non-straight high optical information. With the expansion of optical force, the addition turned out to be exceptionally little and, in the end, progressively incredible. The yield power P_{out} Remained straight for input control pin underneath -20 db, as indicated by tentatively decided outcomes in Figure3.7. However, with the rise in input power of $-10-0.3$ dBm, the saturation of P_{out} is found to be about 6.7 dBm. In the same pattern, with and without modulation, the EDFA was saturated to slightly reduced P_{out} as shown in figure 3.8. The difference in '1' from '0' was very small because the EDFA increases in saturation eliminated the data When the gain was exploited. Experimentally calculating the EDFA output power in Figure3.8 is shown at 1551.40 nm, depending on the input optical power, at 1160 and 850 mA bias currents respectively. From figure 3.8 results, the higher output power at higher EDFA bias currents at the same input power was achieved..

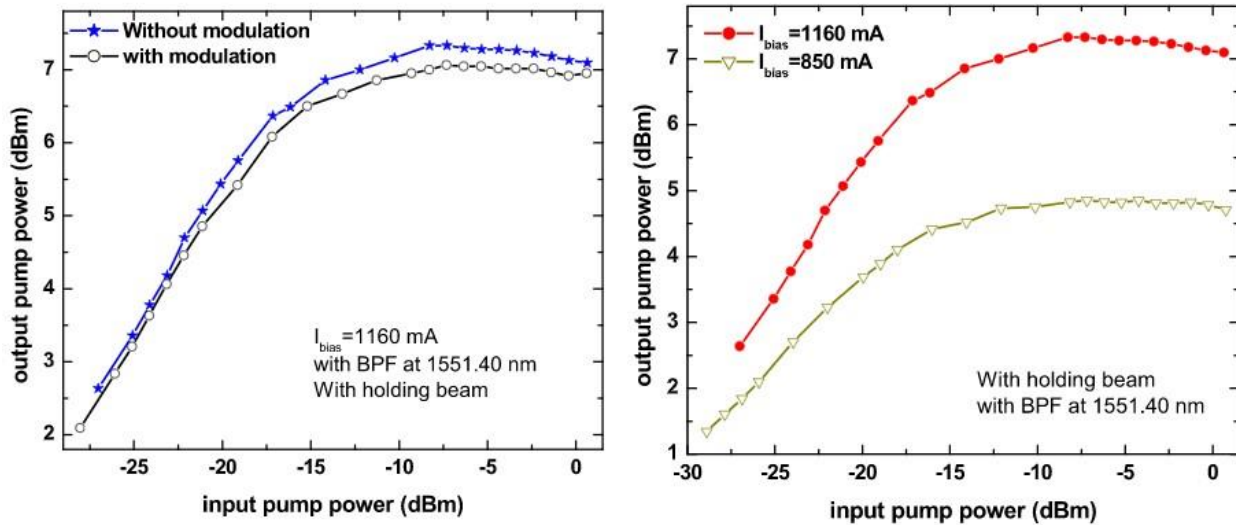

Figure 3.8: Experimentally measured EDFA output power at 1551.40 nm.

3.6 DISCUSSION

In this investigation we accomplished 0.6Tb/s room temperature information transmission with the incorporation of EDFA at 1550 nm in the system. What's more, with the joining of EDFA at 683 nm we likewise arrived at record 125.2mW at 25Gb/s at room temperature for single-mode filaments. EDFA was included with a most extreme quality factor of 34.55 at 863 nm in mistake free activity. In the future we will use the pulse generator Return Zero (RZ) at the transmitter end to operate at the highest wavelength with fiber amplifiers. In future, we will work. We also concentrate on content challenges for the VCSEL device. Short range transmission of high-speed data using wavelength multimode fiber is our key priority for future activities.

3.7 CONCLUSION

An experimentally demonstrated in-complex, colourless downstream, data removal and wavelength reuse technique using economically efficient vertical laser emission surface (VCSEL). A saturated optical EDFA has shown that data from the incoming 0.6Tb / s data signal was effectively removed directly modulated. Implementation of saturated EDFA has shown that for the transmission of 0.6 Tb / s, the data signal's ER is reduced to below 1 dB, allowing for reuse of wavelength. By incorporating EDFA with 863 nm into our system we have achieved data transmission of 0.6Tb / s room temperature.

We are in the future working on the highest temperature at the wavelengths, including fiber amplifiers and also the use of the pulse generator Return Zero (RZ) at the end of the transmitter.

We will also focus on major VCSEL red framework challenges. We do wish to work on potential Ultra-high speed data communication with the use of multimode fiber in our wavelengths.



4. CONCLUSION AND FUTURE WORK

To acquire low misfortune over the whole fiber transmission longer frequency district from 1.3 to 1.6 μm , or then again, exceptionally low misfortune and low scattering at the equivalent working frequency of regularly 1.55 μm , propelled single-mode fiber structure have been economically acknowledged: in particular low-water top fiber and nonzero scattering moved fiber. Although improvement in fiber innovation have been proceeded with quickly over late years, certain recently preferred zones of intrigue, for example, the uses of fluoride filaments for considerably longer frequency activity in the mid-infrared(2 to 5 μm) and far-infrared (8 to 12 μm)mregions have declined due to their inability to exhibit for all intents and purposes the hypothetically anticipated, incredibly low fiber misfortunes joined with the development of optical speakers reasonable for use with silica-based strands. Superior, reliable optical fiber correspondence framework and systems are along these lines currently generally sent inside the overall media transmission and systems and for the most part in progressively confined correspondence application areas. A further scope of adaptability related with optical speakers concerns the ability of specific gadgets to at the same time enhance various WDM optical sign (Sing et al.2013),both semiconductor optical and fiber intensifiers with phantom data transfer capacity in the range 50 to 100nm can be acknowledged which will permit single enhancer to help in excess of 100 force regulated WDM channels. In this chapter the contribution summary and suggestions for the future works are presented. In contribution summary the research proposals and supported themes are highlighted. The flow of work is also mentioned.

4.1 CONTRIBUTION SUMMARY

The progress of the research work has been demonstrated with following primary contributions as,

- a) The performance of EDFA, doped amplifiers is demonstrated comparatively and noted their response in single channel telecommunication systems has been noted.
- b) TEMPERATURE: Firstly, the concept of temperature characteristics of EDFA shows the dependence of amplifier for any operating temperature sensitiveness.

The activity of EDFA when work just with the sign force without siphon has been illustrated, with the low force acting great. In any case, when EDFA worked with siphoning, there was a slight debasement in 20 m EDFA which is increasingly articulated to high misfortune collected at the length of the fiber. Be that as it may, the temperature qualities are prominently ineffectual in 10 m EDFA as the commotion amassed at the fiber end is little.

- i. The aim of the researcher is as the recent optical VCSEL systems require very high power for multichannel system from which the temperature arise of the direct consequence.
- ii. NONLINEARITY: Secondly the EDFA is highly nonlinear for high power leading to the analysis of the concern of EDFA in single channel system for compensated and uncompensated system
- iii. The performance of the telecommunication system is affected by high nonlinearity even at high compensation.
- iv. On considering the NF of EDFA, performance is still contributed good for small distance of 80 Km compared to 27 Km
- v. • A bit error rate is one of the principal parameters that defines the data link efficiency. The efficiency of different data transmission systems can be compared with BER. In table 4.7 we can view the value of BER for various lengths of fiber and figure 4.13 shows the relationship between BER and fiber length without the effect of Noise figure.
- vi. Despite the statement of the compensated system as highly pronounced to Noise of EDFA, the increased performance without noise figure is realized as the effect of dispersion is now controlled by DCF. Validation could be done by seeing the Q produced by the system, where, for longer distance of 480 Km, the uncompensated system produced Q of 3.07 while compensated system shows very high value of 103.07. This is the only consequence of DCF where it perfectly compensates the dispersion along the length of the LEAF
- vii. COMPARISON: The enormous advancement in optical fiber communication not only searches for an alternate idea in increasing bitrate for an alternate idea but also for amplification.
- viii. Although multichannel systems would increase the bit rate the demand for the huge need compels the researcher to increase the single channel efficiency along with multiplication in channels.
- ix. The researcher feels a chain of significant ideas has been provided in this work [TEMPERATURE, NONLINEARITY, MATERIAL USED] and implemented in a system and shown in terms of various performance measures.

4.2 SCOPE OF FUTURE RESEARCH AND SUGGESTIONS

In this research work, a detailed study on Erbium doped and Erbium-Ytterbium Co-doped optical fiber amplifier has been carried out and results obtained justifies the effect in a single channel

telecommunication system. Provision of a very high bandwidth for an increasing population is a highly challenging task for the telecommunication industry. The major concern in considering the long haul transmission lies with the various parameters which are inversely proportional to each other. Long distance transmission experiences high dispersion and thus dispersion compensation is required using DCF. In future these effects would be implemented in multi-channel systems with various coding and dispersion schemes to analyze the pattern effects of bits (Yucel et al. 2014). Also EYDFA finds huge application in integrated photonic circuit comparative to EDFA and YDFA in efficient amplification with small waveguide length. In backbone networks dominate optical fiber and further development is going through DWDM wavelength multiplexing.



REFERENCES

- [1] Abedin, KS, Fini, JM, Thierry, TF, Supradeepa, VR, Zhu Benyuan, Yan, MF, Bansal, L, Monberg, EM, DiGiovanni, DJ 2014, 'Multicore Erbium Doped Fiber Amplifiers for Space Division Multiplexing Systems', *Journal of Light wave Technology*, vol. 32, no. 16, pp. 2800 -2808.
- [2] Ahmad, H, Latif, AA, Norizan, SF, Zulkifli, MZ & Harun, SW 2011, 'Flat and compact switchable dual wavelength output at 1060 nm from ytterbium doped fiber laser with an AWG as a wavelength selector', *Optics & Laser Technology*, vol. 43, no. 3, pp. 550-554.
- [3] Ahmad, H, Zulkifli, AZ, Kiat, YY & Harun, SW 2014, 'Q-switched fibre laser using 21 cm Bismutherbium doped fibre and graphene oxide as saturable absorber', *Optics Communications*, no. 310, pp. 53–57.
- [4] Aleksic, S 2012. 'Energy and Entropy Flow in Erbium-Doped Fiber Amplifiers: A Thermodynamic Approach', *Journal of Light wave technology*, vol. 30, no. 17.
- [5] Alvarez-Chavez, JA, Perez-Sanchez, GG, Herrera, DEC, RodriguezRodriguez, JH & Schreiber, T 2013, 'Temperature sensing characteristics of tapered Yb-doped fiber amplifiers', *Optik*.
- [6] Anthony, R, Lahiri, R & Biswas, S 2014, 'Gain clamped L-band EDFA with forward–backward pumping scheme using fiber Bragg grating', *Optik - International Journal for Light and Electron Optics*, vol. 125, no. 11, pp. 2463-2465.
- [7] Anthony, R, Pain, S & Biswas, S 2012, 'Double Pass Erbium Doped Fiber Amplifier with 100-nm Broadband Optical Amplification for CATV Transmission System', *International Conference on Communications, Devices and Intelligent Systems (CODIS)*, pp. 397- 400.
- [8] Hamdalla, TA 2013, 'Theoretical and artificial neural network modeling for the output power of irradiated erbium doped fiber amplifier', *Optics & Laser Technology*, no. 49, pp. 264-267.
- [9] Arunkumar, S & Marimuthu, K 2015, 'Spectroscopic properties of Er³⁺ doped bismuth leadtelluroborate glasses for 1.53 μm optica amplifiers', *Journal of Alloys and components*, Elsevier, vol. 627, pp. 54-68
- [10] K. Iga, *Fundamentals of Laser Optics*. New York: Plenum Press, 1994.
- [11] Rainer Michalzik and Karl Joachim, "Operating Principles of VCSELs", University of Ulm, Optoelectronics Department, D-89069 Ulm, Germany.

- [12] S. Masumi, "CMOS VCSEL driver circuit for 25+Gbps/channel short-reach parallel optical links", Master's thesis, University of Toronto, Ontario, Canada, 2015.
- [13] Nikolaos Bamiedakis, Jian Chen, Richard V.enty, "Bandwidth Studies on Multimode Polymer Waveguides for •25 Gb/s Optical Interconnects", IEEE photonics technology letters, vol. 26, no. 20, october 15, 2014.
- [14] Daniel M. Kuchta, Alexander V. Rylyakov, "A 50 Gb/s NRZ Modulated 850 nm VCSEL Transmitter Operating Error Free to 90°C", Journal of lightwave technology, vol. 33, no. 4, february 15, 2015.
- [15] Jean-Francois Seurin, Viktor Khalfin, Guoyang Xu, Alexander Miglo, "High-power red VCSEL arrays", Princeton Optronics, Electronics Drive, Mercerville, NJ, USA 08619, 2013.
- [16] P. T. Woan, "In-chip temperature sensing and compensation for VCSEL driver ICs", Master's thesis, Korea Advanced Institute of Science and Technology, Korea, 2012.
- [17] Yu Zhang, "Self-heating control of Edge Emitting and Vertical Cavity Surface Emitting Lasers", PhD work, University of Central Florida, Orlando, Florida, 2012.
- [18] Chen Chen, Paul O. Leisher, Kent D. Choquette, Andrew A. Allerman, Kent M. Geib, "Temperature Analysis of Threshold Current in Infrared Vertical-Cavity Surface-Emitting Lasers", IEEE journal of quantum electronics, vol. 42, no. 10, october 2006.
- [19] J. Piprek, H. Wenzel and G. Sztefka, "Modeling Thermal Effects on the Light vs. Current Characteristic of Gain-Guided Vertical-Cavity Surface-Emitting Lasers", IEEE photonics technology letters, vol. 6, no. 2, february 1994.
- [20] Jeff W. Scott, Randall S. Geels, Scott W. Corzine and Larry A. Coldren, "Modeling Temperature Effects and Spatial Hole Burning to Optimize Vertical-Cavity Surface-Emitting Laser Performance", IEEE journal of quantum electronics, vol 29, no. 5. may 1993.
- [21] K. Johnson, W. Hogan, M. Dummer and G. Breg, "Record high temperature, high power red VCSELs", 15350 25th Ave N, Suite 110, Plymouth, MN 55447 USA, 2011
- [22] Daniel M. Kuchta, Alexander V. Rylyakov, "A 71 Gb/s NRZ Modulated 850 nm VCSEL-based optical link", IEEE photonics technology letters, vol. 27, no. 6, march 2015.