



T.C.
ALINBAŞI UNIVERSITY
Institute of Graduate Studies
Electrical and Computer Engineering Department

MODIFIED PTS SCHEME TECHNIQUE BASED ON
NUMBER ALGORITHM FOR OFDM SYSTEM

Master Thesis

Supervisor

Asst. Prof. Dr. Muhammad ILYAS

Istanbul, 2020

**MODIFIED PTS SCHEME TECHNIQUE BASED ON NUMBER
ALGORITHM FOR OFDM SYSTEM**

By

Hayder Dhahir ALKATRANI

Electrical and Computer Engineering

Submitted to the Institute of Graduate Studies

in partial fulfillment of the requirements for the degree of

Master of Science

ALTINBAŞ UNIVERSITY

2020

The thesis titled “MODIFIED PTS SCHEME TECHNIQUE BASED ON NUMBER ALGORITHM FOR OFDM SYSTEM” prepared and presented by Hayder Dhahir ALKATRANI was accepted as Master Thesis in Electrical and Computer Engineering Department

Asst. Prof.Dr. Muhammad ILYAS

Supervisor

Thesis Defense Jury Members:

Asst. Prof. Muhammad ILYAS

School of Engineering and
Natural Sciences,
Altinbas University

Asst. Prof. Abdullahi Abdu IBRAHIM

School of Engineering and
Natural Sciences,
Altinbas University

Asst. Prof. Akhtar JAMIL

School of Engineering and
Natural Sciences,,
Altinbas University

I certify that this thesis satisfies all the requirements as a thesis for the degree of Master of communication Engineering

Approval Date of Institute of Graduate Studies:

____/____/____

I hereby declare that all information in this document has been obtained and presented in accordance with academic rules and ethical conduct. I also declare that, as required by these rules and conduct, I have fully cited and referenced all material and results that are not original to this work.

Hayder Dhahir ALKATRANI

Signature

DEDICATION

I give you this thesis in a form of appreciation and I may ask Allah to accept this work. Also

I would like to give this work for my mother and father.



ACKNOWLEDGEMENTS

First of all, Thanks for Allah to help me for complete this research. I would like to thank my supervisor, Asst. Prof. Dr. Muhammad Ilyas for great supervision, motivation and friendship. It would have never been possible for me to take Ms Degree without this support.

I would like to thank Dr. Ali Nahir in my supervisory team, he give me good advice in my research and support me in my work.

I would like to thank my best friend Mr. Salam Yassir who constantly encouraged me to do more than enough, His support to me was unlimited for all times and he help me to do chapter 4. I am also grateful to my colleagues in ECE especially Mr.Firas Almater and Altinbas University staff.

I would like to thank my friends in IDC Company who help me through my course.

Last but not least, I would like to express my deepest gratitude to my family my Mother and my Father who support me through my study ,emotionally ,physically and in prayers . I am greatly indented to my wonderful my little brother Mohammed because he help me to get a Vacation for study.

ABSTRACT

MODIFIED PTS SCHEME TECHNIQUE BASED ON NUMBER ALGORITHM FOR OFDM SYSTEM

ALKATRANI, Hayder Dahir

M.Sc., Electrical and Computer Engineering, Altinbas University

Supervisor: Asst. Prof. Dr. Muhammad Ilyas

Date: 2020

Pages: 73

The main problem in the OFDM communication system is the peak to average power ratio (PAPR). This makes the system in a band radiation and band distortion because of non-linearity of the high power amplifier (H.P). There are many ways to reduce the effect of this feature, among these methods that have been used are selective mapping, tone reservation, block coding, filtering, clipping and partial transmit sequence (PTS). In this paper a new algorithm has been proposed which is to use polygon numbers algorithm with conventional partial transmit sequence (C-PTS). This proposed algorithm processes the entered data before sending it, taking advantage of the number non-similarity according to the geometry of the number to prevent similar data successively from being sent directly via PTS, and thus this improved the level of PAPR rise in the proposed system. The amount of reduction in this way has reached more than 8dB. The best result we obtained was the amount of reduction between the conventional method and the proposed method is 4.5683 where $N=64$. In addition, there is no transmission of side information, and this improves transmission efficiency. Finally, this method is easy in the calculation process and in the ciphering and deciphering of data, which adds a few calculations

.Keywords: OFDM, PTS, SLM, PAPR, POLYGON NUMBER

TABLE OF CONTENTS

	<u>Pages</u>
ABSTRACT.....	vii
LIST OF FIGURES	xii
1. INTRODUCTION.....	19
1.1 POWER TRANSMISSION AND MAXIMUM POWER TRANSFER.....	20
1.2 AUTOCORRELATION OF THE ENERGY SIGNAL	21
1.3 AIM AND MOTIVATION OF THE THESIS.....	21
1.4 STRUCTURE OF THE THESIS	22
2. LITERATURE REVIEW.....	23
2.1 PAPR REDUCTION TECHNIQUES THREE VARIOUS METHODS TO DIVIDE THE PAPR.....	23
2.1.1 THE FIRST METHOD:.....	23
2.1.1.1 Deterministic Approach	23
2.1.1.2 Probabilistic Approach.....	23
2.1.2 THE SECOND METHOD.....	25
2.1.2.1 Distortion Based Techniques:	25
2.1.2.2 Scrambling Techniques:.....	26
2.1.3 THE THIRD METHOD:.....	27
2.2 LITERATURE REVIEW	28
3. DIGITAL COMMUNICATION SYSTEMS.....	35
3.1 DIGITAL COMMUNICATION SYSTEMS.....	35
3.2 ORTHOGONAL FREQUENCY DIVISION MULTIPLEXING (OFDM) COMMUNICATION SYSTEMS.....	37
3.3 INTERFERENCES IN OFDM.....	40
3.3.1 Inter- Symbol Interference	40

3.3.2 Inter-Carrier Interference	41
3.3.3 Co-Channel Interference	42
3.4 INTERFERENCES EFFECTS AND CAUSES.....	43
3.5 ADVANTAGES OF OFDM SYSTEM	44
3.6 DISADVANTAGE OF THE OFDM SYSTEM	45
3.7 CHALLENGES IN OFDM SYSTEMS	45
3.7.1 Carrier Frequency Offset (CFO) and Doppler Effect.....	45
3.7.2 Time Synchronization.	45
3.7.3 Peak to Average Power Ratio (PAPR).....	46
.....	48
4. METHODOLOGY	49
4.1 OFDM SYSTEM AND PAPR	49
4.2 PTS SCHEME IN OFDM SYSTEM	50
4.3 NUMBER THEORY.....	53
4.3.1 Polygon Numbers:.....	54
4.3.2 Polygon Formulas:	54
4.3.3 Calculation of Polygon Numbers:	55
5. THE PROPOSED METHOD.....	57
6. SIMULATION RESULTS.....	68
7. CONCLUSION and future work.....	74
7.1 THESIS SUMMARY:.....	74
7.2 FUTURE WORK:	75
REFERENCES.....	76

LIST OF TABLES

	<u>Pages</u>
Table 3.1: Effects and causes the interference.....	43
Table 4.1: characteristics of Polygons Number	56
Table 6.1: Parameters of the Simulation.....	68
Table 6.2: Computational the complexity between the proposed and conventional schemes with different No.subbands	70
Table 6.3 : Computational the complexity between the proposed and conventional scheme with different modulation.....	73

LIST OF FIGURES

	<u>Pages</u>
Figure 2.1: First method classification to reduction PAPR technique.....	25
Figure 2.2: The second method for PAPR Reduction Techniques	27
Figure 3.1: A standard digital communication system	35
Figure 3.2 : Receiver and transmitter sub-systems in a typical digital communication system ...	37
Figure 3.3: Subcarriers in OFDM.....	39
Figure 3.4: Inter symbol interference channel with zero forcing equalizer for BPSK	41
Figure 3.5: Inter-Carrier Interference (ICI) due to frequency offset	42
Figure 3.6: PAPR for a random BPSK signal.....	47
Figure 3.7:PAPR for PBSK and QPSK	48
Figure 4.1: OFDM Block diagram Transmitter and Receiver	50
Figure 4.2: Block diagram Of PTS	53
Figure 4.3: Type of polygon number triangular, square, pentagonal, and hexagonal	54
Figure 5.1: Input sequent numbers Different values	57
Figure 5.2 : processing Number with Autocorrelation	58
Figure 5.3: Autocorrelation with Different values.....	59

Figure 5.4: The Effect of the increase over 3 groups same groups.....	59
Figure 5.5: The Effect of the increase over 3 groups change the pentagonal with different groups	61
Figure 5.6: Data input with range of magnitude 1.2-2.2.....	61
Figure 5.7: Data processing with range of magnitude 1.2-2.2.....	62
Figure 5.8: Data input with range of magnitude 2.2-3.2.....	63
Figure 5.9: Data processing with range of magnitude 2.2-3.2.....	63
Figure 5.10: Shape of the data input with Polygon Number.....	64
Figure 5.11: proposed algorithm.....	65
Figure 5.12: Processing the data input with the proposed method	65
Figure 5.13: Block diagram of the propose method with C- PTS scheme	65
Figure 6.1: PAPR performance of proposed scheme with C-PTS and SLM schemes for 4 QPSK	69
Figure 6.2: PAPR performance of proposed scheme with C-PTS and SLM schemes with 8QPSK	71
Figure 6.3: PAPR performance of proposed scheme with C-PTS and SLM schemes with 16 QPSK	72

Figure 6.4: PAPR performance of proposed scheme with C-PTS and SLM schemes with 64 QPSK 73



LIST OF ABBREVIATIONS

OFDM	Orthogonal Frequency Division Multiplexing
PAPR	Peak-To-Average Power Ratio
RF	Radio Frequency
GSM	Mobile Communication
CDMA	Code Division Multiple Access
IP	Internet Protocols
WLANS	Wireless Local Area Networks
OOB	Out-Of-Band
PTS	Partial Transmit Sequence
C-PTS	Conventional Partial Transmit Sequence
SLM	Selected Mapping
HPA	High Power Amplifier
SI	Side Information
DAC	Convert Digital-To-Analog
ISI	Inter-Symbol Interference
ICI	Inter-Carrier Interference
CCI	Co-Channel Interference
BER	Bit Error Rate
A/D	Analog-To-Digital
D/A	Digital-To-Analog
CFO	Carrier Frequency Offset

FFT	Fast Fourier Transform
IFFT	Inverse Fast Fourier Transform
SNR	Signal To Noise Ratio
RMS	Root-Mean-Square
ACE	Constellation Extension
ML	Maximum Likelihood
AWGN	Additive White Gaussian Noise
QPSK	Quadrature Phase Shift Keying
PEP	Pairwise Error Probability
RC-PTS	Reduced-Complexity Pts
P-ABC	Parallel Artificial Bee Colony
MIMO-OFDM	Multiple-Input, Multiple-Output Orthogonal Frequency-Division Multiplexing
LTE	Long Term Evolution
I-SLM	Iterative Slm
SCR	Signal To Clipping Noise Ratio
S-SCR	Scale
MS-SCR	Multiple Scaling Scr
LM	Lagrange Multiplier
MMSE	Minimum Mean Square Error
ICF	Iterative Clipping And Filtering
EVM	Error Vector Magnitude
CNC	Clipping Noise Compression
DPD	Digital Pre-Distortion

PA	Power Amplifier
PSD	Power Spectral Density
PCC	Patient-Centered Communication
QAM	Quadrature Amplitude Modulation
APSK	Amplitude-Phase Shift Keying
QF	Quality Factor
NDZ	No Detection Zone
F-OFDM	Filter -Orthogonal Frequency Division Multiplexing
ICEF	Iterative Clipping And Error Filtering
PRBS	Physical Resource Blocks
URLLC	Ultra-Reliable Low-Latency Communication
MCS	Modulation And Coding Scheme
CCDF	Complementary Cumulative Distribution Function
ISM	Scientific And Medical
RL	Resistor Inductor

LIST OF SYMBOLS

$E[\cdot]$	Expectation operator
$[\cdot]^T$	symbol modulating for one set of subcarrier
T	signal duration
Δf	separation of subcarrier
ξ	constellation symbols
M	Sub blocks
P	Phase factor
\odot	Element wise multiplication
p_n^r	n th r -gonal number
t_n	triangular number
P_n	pentagonal number
h_n	hexagonal number

1. INTRODUCTION

There are two categories for digital modulation techniques. The first one-carrier modulation, where data is transmitted using a single carrier radio frequency (RF). The other is, in which data is sent by modulating several RF carriers simultaneously. This is called orthogonal frequency division multiplexing (OFDM)[1]

Several factors have spurred the development of energy-efficient telephone interface systems and bandwidth, including competition for high-speed wireless applications in addition to the radio frequency signal's restricted bandwidth. In the early eighties, after the increase in the development of phones cellular analog cellular systems were introduced as subscribers increased their growth in cellular voice services mainly. Throughout the early 1990s, several second-generation cellular standards were adopted, like the Global Mobile Communication System (GSM) and Code Division Multiple Access (CDMA), owing to the growing demand for voice services and the availability of greater network capacities.

This development continued in a very big way, wired internet protocols (IP), and the growing demand for wireless data and multimedia apps. And the evolution continued until we appeared in the 3G of cellular standards like CDMA, WCDMA and CDMA2000. With the continuous development of more and more cellular and internet networks and basic networks based on Internet protocols and support for sensitive applications such as (VoIP). After that, wireless local area networks (WLANs) appeared, as these were under IEEE802.11 for development which enables the mobile phone to connect to the Internet, and later developed into IEEE802.11b which is known as Wi-Fi, and recently developed to IEEE802.11a / g provides high speed In the wireless connection. In light of the development of modern technologies and the increasing demand for high capacities or the use of IEEE802.11a uses OFDM similar to IEEE802 and also uses IEEE802.16 In addition to that mobile environments that use IEEE802.20 depend on OFDM. The IEEE802.11n (MIMO) standard allowing multiple inputs and multiple output system has also been revised.

It is very important to understand the basic characteristics of radio propagation and to understand the disadvantages and advantages of OFDM, there are three mechanisms in general that spread radio waves which are diffraction, reflection, and scattering. To design any wireless system, three independent basic phenomena depend on it should be taken for describing radio propagation, which is multipath fading, path loss attenuation with distance. [2] If we take bone of the communications today which is OFDM used in the 4G and is still used even in the 5G, we will explain it in the second chapter in detail, but the basic idea of OFDM system is to parallel express symbol blocks by employing a large number of orthogonal sub-carriers. With block transmission, the source symbols are transformed into a block of modulated parallel symbols each with a much longer time than the length of the ISI channel, as the symbol rate on each subcarrier is much lower than the source rate.[3]

1.1 POWER TRANSMISSION AND MAXIMUM POWER TRANSFER

An important factor in every electrical or electronic circuit must be considered power there are two primary tools in a communication system: transmitted capacity, and channel bandwidth. The power expressed is the average received signal power. The bandwidth of the channel indicates the band of substantial frequency components allocated for input (message) transmission. Either of these two services may be more important than the other; therefore, communication networks are usually known as band-limited, such as the public switched telephone network's local access, or limited capacity, such as satellite channels.

In the field of communication, the amount of power used to transmit a signal is very significant as to the extent to which this signal can be transmitted and what is the energy needed to transmit this signal. This simply explains how "impeded" a current flow is along its way. One of the key considerations when transmitting and receiving the signal is that no signal is lost when this signal is received by an antenna through which the full energy is transmitted perfectly. How can we achieve that? For example, we take a simple electrical circuit to explain the amount of power loss and its resistance, and we wonder what amount of RL would give the maximum energy transferred to this charge? Here the presumption is that the source has RS resistance, and this

may in fact consist of internal resistance of the voltage source and corresponding circuit resistance. Therefore, it is very important to conserve power, as increased power consumption means less battery life for the transmitters and a higher cost..[4]

1.2 AUTOCORRELATION OF THE ENERGY SIGNAL

The autocorrelation, whose function is to calculate the amount of similarity between the signal and its delay version for a real value energy signal. The time lag is the scanning parameter which helps to know the autocorrelation function. The autocorrelation function is a real valued, even function, the limit of which reflects the signal energy and occurs at the origin.[3]

A well-known feature of autocorrelation is a property that conserves pole. For example, if a signal in a polar sequence is constructed, the poles of the autocorrelation sequence will be the same as the original signal..[5] We have used this function for work to reduce the energy surge, as described in the Chapter 5.

1.3 AIM AND MOTIVATION OF THE THESIS

The work in this thesis focuses on the OFDM system .OFDM the best witch solutions in wireless communication technology have led to huge success for fast data transfer rates. High peak to average power ratio (PAPR) is an OFDM disadvantage, which saturates the power amplifier, causes more interference and decreases nonlinear part resolution such as digital / analog converters[6] So the challenges persisted to find ways to reduce the high of the PAPR and several approaches appeared to reduce it. One of this scheme called partial transmit sequence (PTS). This approach is perfect for decrease, but complexity[7].

The main research focus on decrease the PAPR in OFDM system to detector lower PAPR.

Most published article research on reduction PAPR assume perfect knowledge of the existing estimation schemes suffer from not analyze the input data in [8] .The aim of this study is to enhance from high of the PAPR in OFDM system by analyze the data input and use Simple algorithms in ciphering and deciphering to preserving good performance on errors and prevent the similarity of the data input in transmission. Furthermore, send the data without side information. This can be extended to practical systems.

1.4 STRUCTURE OF THE THESIS

This thesis consist of 7 chapters, subsequent to this introductory chapter. The thesis organization, as listed below.

Chapter 2: Literature Review on reduction the peak to average power ratio schemes in OFDM system.

Chapter 3. Contains a9+ detailed digital Communication Systems and principles of Orthogonal Frequency Division Multiplexing (OFDM) Communication Systems, advantage, disadvantage and the challenge for OFDM.

Chapter 4: Methodology of OFDM system and PAPR, conventional PTS scheme.

Chapter 5: The proposed method that used to reduction the PAPR

Chapter 6: Simulation results.

Chapter 7: Conclusion and Future Work

2. LITERATURE REVIEW

2.1 PAPR REDUCTION TECHNIQUES THREE VARIOUS METHODS TO DIVIDE THE PAPR

2.1.1 THE FIRST METHOD:

In deterministic and probabilistic approaches, several techniques are employed to reduce PAPR. The probability of the OFDM signal's PAPR likelihood exceeding a default threshold while the OFDM signal's PAPR deterministic must not exceed a predefined threshold. The sections for those categories are as follows:

2.1.1.1 Deterministic Approach

This technique of reducing PAPR depends on clipping relative to the time domain or frequency-dependent coding, and the simplest method is to cut the signal amplitude before amplification [9]. The clipping technique alone is not sufficient to reduce PAPR as this technique has problems and defects such as spectral regrowth and signal distortion. Modified shear techniques are part of the potential approach. As for coding techniques, they are used on OFDM signals to assign small values to codes [10].

2.1.1.2 Probabilistic Approach

The number of OFDM-symbols occurring is huge, so probabilistic approaches attempt to reduce it as PAPR values exceed a predefined threshold, In addition, it reduces spectral growth and signal distortion at the same time, the probabilistic approaches are divided into time domain, or the processing of frequency domains involves:

- time Domain-Based Processing

These approaches to classification are called blind and non-blind techniques which focus mainly on the signal processing power in the time domain. There is a difference between the two

techniques found in the receiver, where the first technology is the Blind technique. The receiver is ignorant of the changes being made on the transmitter side. However, non-blind methods, the receiver needs previous information of the necessary changes on the transmitter side. Therefore, non-blind techniques are considered better than blind technologies because They require considerable side information to work and reduce deterioration and system errors where the receiver has information on the changes taking place on the sender side. The blind technique to the PAPR is very simple: Clip the amplitude of the signal to a predetermined value and filter the signal. This process can result in spectral regrowth, so this technique is not considered to be effective in reducing OFDM signals PAPR. Despite the many algorithms used in amplitude clipping and filtering to reduce PAPR, the degradation issue was not eliminated because of the inter-carrier interference (ICI) caused by clipping[11].

- Frequency Domain-Based Processing

It is high as is known in the OFDM signal PAPR. Therefore, these processing approaches on the Frequency domain try to reduce the correlation of the input signals to the lowest possible level, as this is done by changing the input sequential phase and/or power, and some methods that attempt to manipulate the input signal correlation. Reducing the OFDM signal's PAPR is by modifying the sub-carrier phase to reduce the coherence between the various sub-carriers, and this modification technique is called blind phase adjustment. To maintain signal performance and achieve a slight bit-error rate (BER), the phase adjustments should be small[12].

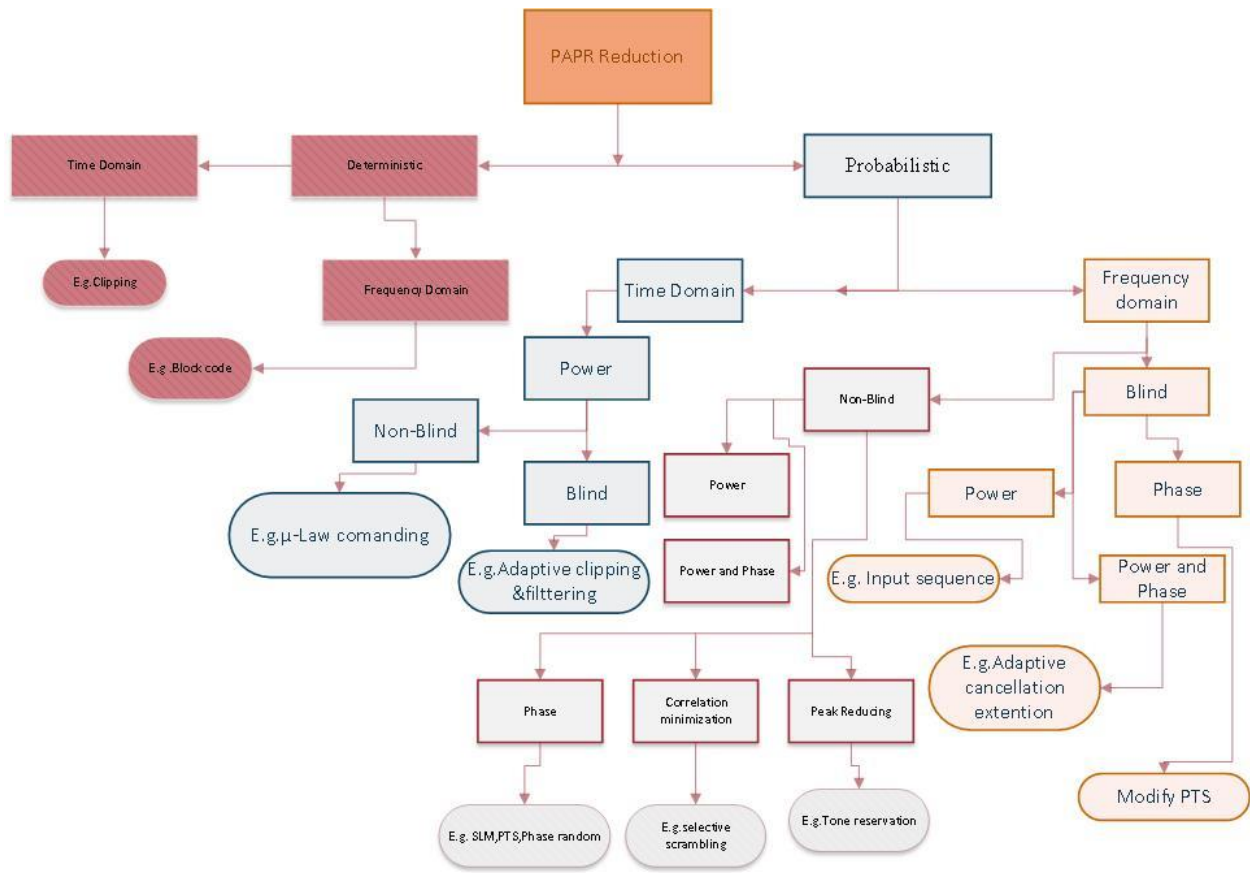

Figure 2.1: First method classification to reduction PAPR technique [60]

2.1.2 THE SECOND METHOD

Divided in two Techniques:

2.1.2.1 Distortion Based Techniques:

One of the direct ways of reducing PAPR is distortion-based technology. This is part of spectral re-growth techniques and the deformation obtained can be corrected by using filtering. The PAPR reduction is by non-linear signal distortion. This is after the signal generation (IFFT). Examples of this method are non-linear companding, windowing, clipping, and filtering.

The method of distortion in reducing the PAPR signal processing before amplification. A simple method of signal processing is clipping of signal before amplification, but this method affects system performance and interference and also causes an increase in both the out-of-band (OOB) range. Many of the techniques used to reduce PAPR and some of them are characterized by high efficiency, but there is a basic point that must be available in the technology used to reduce PAPR, it must be compatible with current modulation schemes, and also it should not be computationally complex and highly efficient [13]

2.1.2.2 Scrambling Techniques:

This technique is applied to the transmission rate signal and is bit-level dual processing that makes the resulting binary sequence more random. For this method, the signal is various types of symbol coding to reduce PAPR, many methods can be used to effectively scramble complementary Golay sequences, Shapiro-Rudin sequences, coding methods, M sequences, and Barker symbols to reduce PAPR. Block coding is the most practical solution for signal scrambling techniques, partial transmission sequence (PTS), and selective level mapping (SLM)[14]. Below showed figure(2.2) the second method for PAPR Reduction Techniques

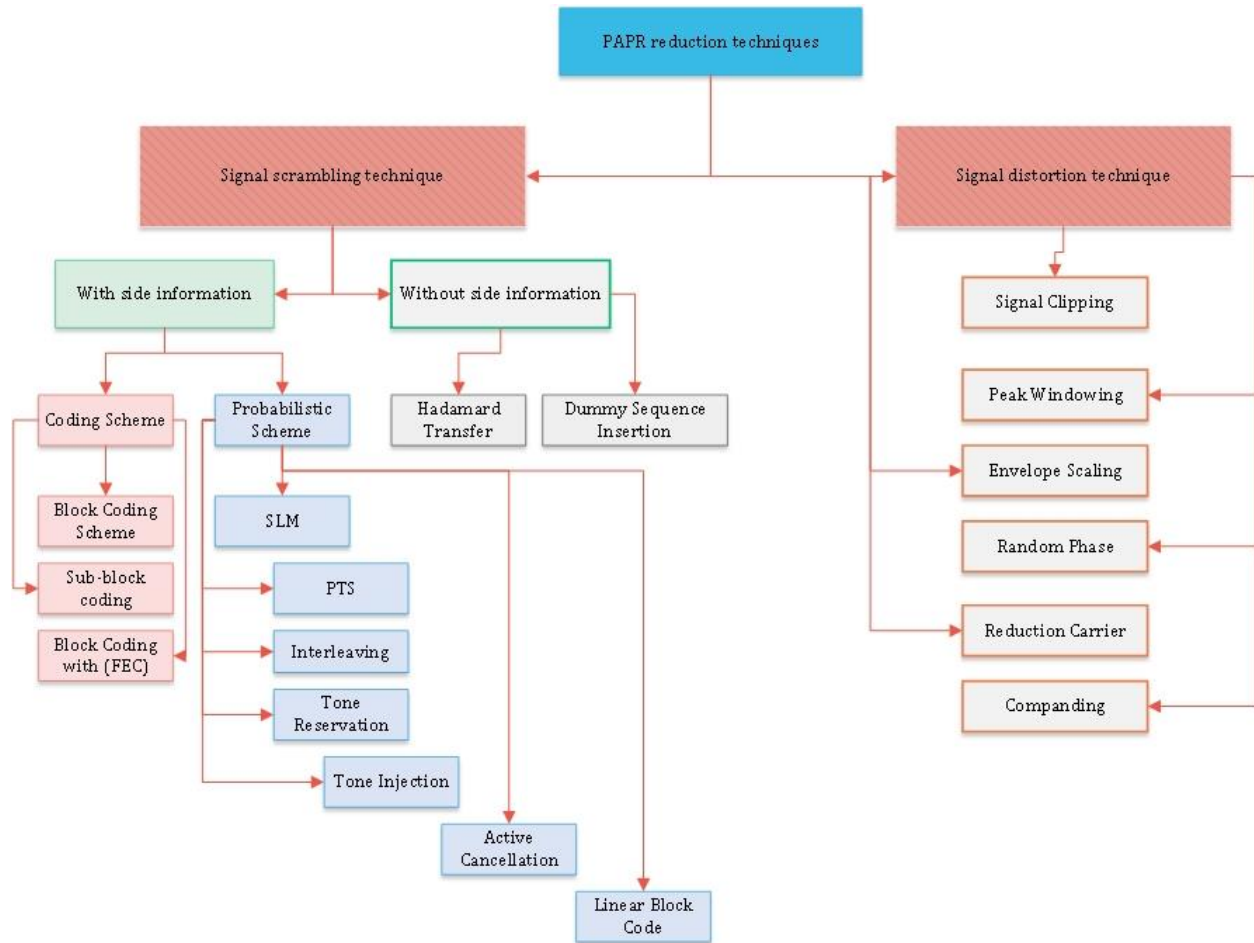

Figure 2.2: The second method for PAPR Reduction Techniques [60]

2.1.3 THE THIRD METHOD:

Dividing these approaches into four categories:

- (1) The technique of clipping
- (2) Code Methods,
- (3) Probabilistic Methods (Scrambling)
- (4) Methods of Predistortion

2.2 LITERATURE REVIEW

- (1) **2011, Yang, L., Soo, K. K., Li, S. Q., & Siu, Y. M.:** in this paper show that's the conventional Partial transmit sequence (C-PTS) and the high computational complexity problem and the transmission of multiple side information bits. The key idea is to build the candidates via the periodic transformation so that there is a sub-block in the time domain for each sequence and they are combined in a recurring way. Without side information the detection system can retrieve the original signal by taking advantage of the phase constellation's natural diversity for various individuals. With high reliability the detector can function without side information. This approach achieves the same BER and is similar to C-PTS with regard to the accuracy of side details according to the Rayleigh fading channel and the AWGN system. [8]
- (2) **2017, Joo, H. S., Kim, K. H., No, J. S., & Shin, D. J.:** In this paper, the concept in this research is to the peak-to - average power ratio of multiplexer signals where the PTS is transmitted without side information by OFDM signal .The identifiable phase offset is carried out on the elements of each rotating vector where the proposed SI diagrams are not transmitted and the rotating vector is specified. To restore the data sequence from the received signal without SI, the maximum likelihood (ML) detector is used. As a result of the phase offset between the constellation of the rotating signal and the constellation of the concerned signal, ML can detect this Euclidean distance. To verify the efficiency of the proposed method, a good phase offset is selected to include the SI and Study of the pairwise error probability (PEP) and the performance degradation resulting from the failure of the SI detection, as well as the final stage, the numerical analysis that shows the bit error rate (BER).[15]
- (3) **2017, Chen, Houston, and Kuo-Chen Chung:** In this paper, It is suggested to specify the OFDM signal transmitted with the minimum PAPR by linear code method with good trellis and then send the side information with error correction. There are two primary reasons for collecting PTS and the trellis strategy to provide low-complex PTS and error-protection capability for side information. This method achieved lower complexity and a good reduction in PAPR compared to other PTS.[16]

(4) **2018, Lee, Kang-Seok, Hoon Kang, and Jong-Seon No.** : In this paper, Focusing on reducing computational complexity with new PTS schemes, and use dominant time-domain tests for OFDM signals. The result of PAPR reduction and computational complexity was reduced compared to conventional PTS schemes.[17]

(5) **2019, Zhou, Zhuang, Lingyin Wang, and Chi Hu:** In this paper, In this study, two new measures were included in selecting samples of low complexity concerning Samples of dominant time-domain in the PTS scheme. There are two factors in this method for measuring the proposed pattern: the number of sub-blocks for each group and the mean power of the candidate signals. It is also mentioned that there are several factors in the strength of the filtered signals according to the reduced-complexity PTS (RC-PTS) scale, this is the additional number of sub-blocks, the number of sub-carriers and the least possibility of catching the OFDM signal. Thus, the proposed approach suggests that comparison with RC-PTS easily acquires the dominant field sample selection threshold and helps with output reliability and achieve strong PAPR with greater reduction in computational complexity.[18]

(6) **2015, Woo, J. Y., Joo, H. S., Kim, K. H., No, J. S., & Shin, D. J.:** There is a proposed low-complex method called a Class-III SLM scheme that generates one inverse fast Fourier transform (IFFT) to consider different OFDM signal streams. By choosing the rotation values and the cyclic shift at random, a Class III SLM system can create up to N^3 of alternate OFDM signal sequences in which N is IFFT. Not all OFDM signal sequences, though N^3 perform well for PAPR reduction. The method for selecting cyclic shift values suggested in this paper was acceptable in order to reduce the variance of correlation values between the consequences of the alternative OFDM signal, the spin values are useless when $U \leq N / 8$, and that U represents the number of sequences of the alternative OFDM signal. Besides, when $U > N / 8$ is suitable for rotation values and its performance is better in reducing the PAPR compared to the above method, it also requires less side information than the random scheme. There are two key advantages in this method, the previous method needs memory for three complex numbers (rotation values), but you don't need memory for the rotation values in the proposed method, the second advantage needs just $\log_2 U$ bits for side information if the periodic transformation values.[19]

(7) **2015, Taşpınar, Necmi, and Mahmut Yıldırım:** In this letter, they find a new method for reducing PAPR by using selected mapping (SLM) scheme which is called parallel artificial bee colony (P-ABC) algorithm. After testing the performance of the proposed algorithm, P-ABC, using selected mapping (SLM) scheme in both OFDM and MIMO –OFDM Systems. Additionally, they propose two separate ABC-ABC / best/1 algorithms, and updated ABC / best/1. The algorithms have performed well to reduce PAPR and low computational complexity bitrate performance.[20].

(8) **2018, Mestdagh, D. J. G., JL Gulfo Monsalve, and J-M. Brossier:** In this paper, a new method proposed to reduction PAPR for (SLM-OFDM) that generates $(U^2/4)$ symbol candidates using U inverse fast Fourier transform is presented. That's called GreenOFDM. This method is considered good compared to other methods used SLM-OFDM. Green OFDM is also excellent at splitting multiple accesses of a single carrier frequency division because to its ability to reduce PAPR and useful for LTE-A techniques.[21]

(9) **2019, Al-Rayif, M. I., Seleem, H., Ragheb, A., & Alshebeili, S.:** The method used in this paper is an algorithm called iterative SLM (I-SLM). A set of vectors for the orthogonal process is generated in this method. It depends on the Hadamar orthogonal matrix, and the generated vectors are repetitive. Several alternative OFDM symbol sets are iteratively generated which is a transmission of the determinative sets having the lowest peak power. The expansion factors C, the number of iterations subcarriers K and M represent the performance of the technique used in different sizes. If $k = 256$ the PAPR reduction value is 3dB from the original OFDM curve.[22]

(10) **2019, Wang, Jingqi, Xin Lv, and Wen Wu:** In this letter, the method that works on a square algorithm to calculate the best clipping noise. This method is called the SCR Scale (S-SCR) as it improves the convergence rate and computational complexity. Also, this method has been modified and developed to scale Matrix format to obtain the best reduction in PAPR and the new scheme called MS-SCR scheme as it has multiple peaks in one iteration. The decreased in this method (S-SCR and MS-SCR) compared to other conventional methods is increased by 38.52% and 27.36%, respectively[23]

(11) **2017, Anoh, K., Tanriover, C., Adebisi, B., & Hammoudeh, M.:** The method used in this paper to reduce PAPR is depending on clipping and filtering to cut the excess amplitude to approach the uniform distribution where the size distribution of the conventional OFDM system is converted to a uniform distribution, in this method the mean amplitude is used as a source of the reference amplitude, Optimize the number of iterations used in the adaptive mode by using the Lagrange multiplier (LM). To reduce the BER rate, The minimum square error form was used because the PAPR reduction scheme was non-linearly attenuated. The optimisation of the LM used in this approach has been found to be better than traditional adaptive iterative clipping and filtering. The best performance to reduce nonlinear distortions is when using MMSE after ICF, and when signaling through HPA.[24]

(12) **2019, Tang, B., Qin, K., Zhang, X., & Chen, C.:** In this research paper, Compare the old method Iterative clipping and filtering (ICF) to reduce PAPR and the proposed scheme which is called a clipping-noise compression process as the old method typically requires multiple transformations between the frequency domain and the time domain and iteration numbers by clipping and noise compression. The basic idea of the proposed approach is to clip the noise and change the signal in the time domain where this procedure decreases computational complexity and performs only one IFFT operation.[25]

(13) **2019, Liu, X., Zhang, X., Xiong, J., Gu, F., & Wei, J.:** In this paper, One of the problems raised in this study is the problem of convex optimization that reduces the size of error vector magnitude (EVM). They observed that when solving the problem of convex optimization, the computational complexity increases with it. Therefore, a new method has been proposed to solve these problems, which is based on the reduction of the PAPR signal in which the time-domain kernel matrix is used, in addition to this it reduces the clipping noise that is in the form of a series of unconnected equivalent impulses. The proposed TKM-ICF method has good performance in terms of reducing PAPR and EVM, It was much better than other methods like iterative clipping and filtering.[26]

(14) **2019, Tang, B., Qin, K., Mei, H., & Chen, C.:** In this paper, it is mentioned that there are many ICF-based methods for easy implementation and an optimized ICF (OICF) is designed

with an optimized filter. This gives him a quick convergence rate strength. There is also a simplified SOICF method that uses Lagrange multiplication to solve problems compared to OICF as this method is good in terms of improving the complex convex. Also, other methods have been discovered to reduce the required number of instant conversions, such as the clipping noise compression (CNC) method, which depends on SOICF. As for the main method suggested in this paper, is the use of clipping noise compression technology to calculate a vector of PAPR in SOICF as has been improved to enter the pressure threshold. But this method has more arithmetic complexity than the other methods that I mentioned except that it has less PAPR and BER especially with higher modulation or lower clipping ratio.[27]

(15) **2011, Varahram, Pooria, and Borhanuddin Mohd Ali:** In the previous conventional method (CPTS) there are Complications in calculations to obtain, in addition to the (IFFT) optimized phase sequence. The method proposed in this paper is a new phase sequence of the PTS method working on the proposed matrix of approach. The basis for doing this method is first to create random phase factors and then multiply it with the input signal, When comparing C-PTS with the method suggested, we note that the IFFT reduction processes are reduced in half and this gives them less complexity than the previous method, in addition to that applying both the PAPR and DPD reduction with PSD output suppression further and this leads to less energy consumption and give life The battery lasts longer.[28]

(16) **2017, Ali, Moftah, Raveendra K. Rao, and Vijay Parsa:** The clipping technique utilized measured values of standard deviations of real and imaginary parts of complex discrete samples of OFDM symbols. The method proposed in this paper is the technique of cutting the differentiation between PAPR and BER which uses OFDM symbol statistics and the function by which the clip level is determined $a\sigma_R/I$ for $0 < a\sigma_R/I < 4$, where $a\sigma_R/I$ The method proposed in this paper is the technique of cutting the differentiation between PAPR and BER which uses OFDM symbol statistics and the function by which the clip level is determined $a\sigma_R/I$ for $0 < a\sigma_R/I < 4$, where $a\sigma_R/I$ to normal distributions of real and imaginary parts of QPSK. This technology provides easy control to reduce PAPR during the clipping level process.[29]

(17) **2018, Idris, A., Sapari, N. L. M., Idris, M. S., Sarnin, S. S., Mohamad, W. N. W., & Naim, N. F:** To overcome problems arising with OFDM. In this paper, the performance of OFDM and F-OFDM are shown in terms of PAPR. Two coding methods were used, namely Reed-Solomon code and Arithmetic code, to reduce PAPR. The Arithmetic code method was more efficient in reducing PAPR. The percentage that both methods can reduce is estimated at 18.5% of the PAPR in OFDM and 12% in F-OFDM, This makes the system easier to use and gives a longer battery life. Besides, the APSK 64 modulation technique was found to be better than the QAM 64 modulation technique because it was less BER.[30]

(18) **2019, Gökceli, S., Levanen, T., Riihonen, T., Renfors, M., & Valkama, M.:** In this paper, discusses the conventional approaches in the OFDM program that are focused on reducing PAPR. The old method is clipping and filtering as the clipping noise passes through the band and this leads to a decrease in the quality of the transmission signal. As for the new method proposed in this paper was dependent on separating the clipping noise prevailing in each iteration, this method is known as clipping, iterative clipping and error filtering (ICEF) where the frequency mask field depends on controlling different physical resource blocks(PRBs). This method has given the ability to control the PAPR more than the rest of the methods to control the clipping noise and filter it flexibly, which gives flexibility and quality in the transmitted signal as this can be used in the context of the 5G NR system in addition to that it is strong against the precise allocations of clean PRBs and can To be used for URLLC reliability or high throughput MCS.[31]

(19) **2019, Liang, Hsin-Ying:** In this paper, the SLM method the OFDM system used to reduce PAPR has been improved. It randomly generates phase sequences which increases system complexity and lack of systematic structure .The method that was proposed and used as an adaptive threshold (PAPRTHD) which depended on the phase-generation mechanism for each modified datum. Therefore, the systematic structure of Reed-Muller codes could improve is best from the traditional SLM method that was causing the lack of a systemic structure. Besides, the method proposed when used with PR-SLM technology reduces large amount of bits needed for side information. The submatrices G_s and G_m are used to adapt to the OFDM system.[32]

(20) **2019 Kim, Dong-Uk, and Sungmin Kim:** There is a process called the islanding operation, and this shows the source of the utility voltage if it is connected to the grid or not and if the local loads are separate from the source of the utility voltage. To detect islets in the reflective system connected to the grid, a new method was used. In this paper, the voltage is calculated by PCC using phase-shifted feed-forward voltage and the change in the calculated PCC frequency, it is possible to modify the forward phase to detect the state of the islands and the phase of the feeding voltage can be adjusted too[33]. The most important advantages in this method are

- 1- The inverter output power quality is not less because it does not produce continuous interactive energy.
- 2- The frequency response speed is fast because the islanding activity can be detected at 90 ms given the high quality factor (QF), 10.
- 3- The frequency of the grid changes in the permissible band and does not affect the grid condition.
- 4- It contains a very low NDZ, since reactive energy injection is not constrained.

3. DIGITAL COMMUNICATION SYSTEMS

3.1 DIGITAL COMMUNICATION SYSTEMS

The method of moving information from one point to another by the use of a different collection of symbols called the digital system. Over the last years, researchers have paid great attention to studying this system accurately and continuously as a result of the development and increase in the use of digital communication systems on a very wide level and studies are still ongoing due to the increased demand for data communications, Digital signals are easy to regeneration, highly efficient in processing data and multiple options, and they are more flexible compared to analog transmission[34]. Figure (3.1) displays a block diagram of a typical digital communication system

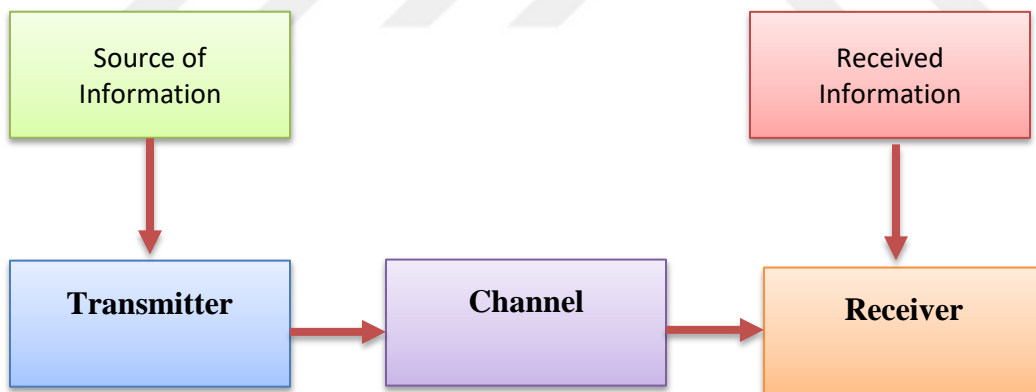

Figure 3.1: A standard digital communication system

Digital communication is much better than analog communication as it is less prone to distortion and interference since digital communications operate in one of two states (0,1) And so disruptions are considerable to shift the circuit's operating point from one state to another. These operating systems achieve very low error rates and produce reliable signals that errors can be detected and corrected in addition to these systems where the signal is Simple to regenerate,

preventing noise and other disturbances which impede the transmission process. In addition to the aforementioned benefits, modern communications do have several other major advantages as follows:

- Digital communications are reliable and low cost in their production
- The flexibility of implementation enables use in digital hardware
- Digital communication has evolved a lot in addressing interference and interference in signals, and this maintains privacy and a high level of protection
- Communications expanded to multiple levels and different parties. This enabled a large amount of data to be communicated, such as a computer-to - computer connection or from peripheral devices or terminals to a computer, and these are better via digital communications links. In the figure below is a model for the digital communication of the receiver and transmitter of the subsystem signal [3].

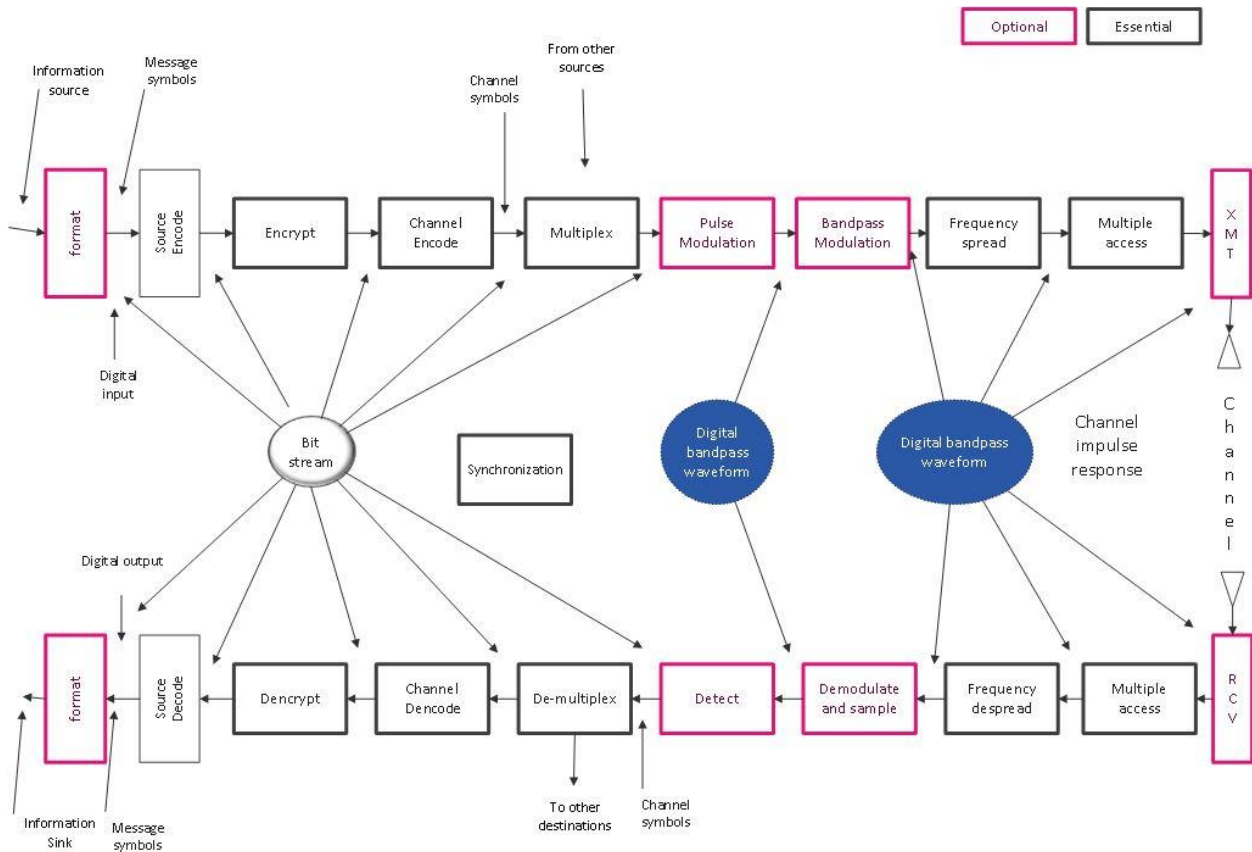

Figure 3.2 : Receiver and transmitter sub-systems in a typical digital communication system[34]

3.2 ORTHOGONAL FREQUENCY DIVISION MULTIPLEXING (OFDM) COMMUNICATION SYSTEMS

The Orthogonal frequency division multiplexing (OFDM) is a frequency division scheme in which the carrier frequencies are very close yet do not interfere with each other. The frequency spacing that uses in OFDM is very small and its symbol period is bigger than or equal to the reciprocation of this spacing, OFDM usually has a high symbol duration, which reduces inter-symbol interference (ISI) [35]. Particularly in a multipath environment, a common problem with wireless communication is that the ISI prevents high-speed communication. So OFDM enables

communication of high productivity by increasing the number of carrier frequencies and retaining high spectral efficiency. Nevertheless, it has implementation challenges. OFDM signals have trouble with high peak-to-average power ratio (PAPR), to convert digital-to-analog (DAC) signal with high PAPR requires a high-speed and a large dynamic-range amplifier for perfect signal. These components are very expensive and lead to energy loss. Thus lead to shorter battery life in portable devices, as well as heat loss is not desirable in a fixed device[36]. One of the issues to remember in multi-carrier transmission is the high-power ratio to regular signal transmission. [7].So this minimizes the range of the OFDM signal transmission. Furthermore, the transmit power enhancer must be operated in its direct district to prevent defects of the OFDM signal as a burial correction between out-of-band radiation and the subcarriers. It is necessary to work to improve the transmission capacity in his immediate area. Therefore OFDM signal needs widespread backing and this conversion is a waste of power[37]. Due to the high peak-to - average power ratio (PAPR), OFDM is insensitive to the non-linear effects of power amplifiers and this is one of the major problems in this system.[38] There are a lot of problems caused by high PAPR as it limits its wide use in some communications devices, and it is not preferred to use it in uplink transmission due to the restrictions in it.[39] It also leads to the consumption of large amounts of energy as the power amplifiers operate in the saturation region and this leads to the deterioration of the bit error rate (BER).[40] In addition, due to the nonlinearity in the power amplifier, high PAPR results in intermodulation and out-of-band radiation [41].

OFDM is the division of wide frequency into small frequencies where this split frequency is called the sub-carriers and the graphic below shows the process of transferring data to each of these sub-carriers. This type is known as multiplexing, where wide frequencies are divided into multiple small/narrow frequencies and all data is transmitted on the subcarriers simultaneously[1].

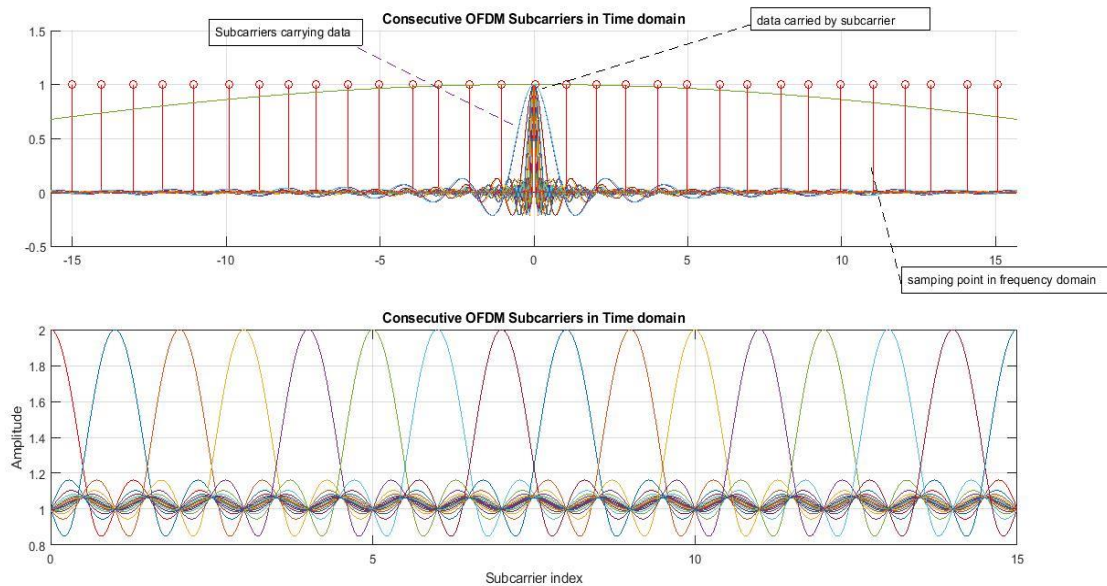

Figure 3.3: Subcarriers in OFDM

For the purpose of understanding the orthogonality of OFDM, the diagram above shows that, after dividing the band into multiple subcarriers, there is one subcarrier that has a non-zero value and all other subcarriers have a value of zero at the sampling point and this is known as the "orthogonally" Orthogonal means No "Interference"[1].

3.3 INTERFERENCES IN OFDM

There is interference in the OFDM system. There are two self-generated interfaces, ISI and CCI. This type of interference is external and affects the system with other applications. Interference divided into three types as detail down

3.3.1 Inter- Symbol Interference

The channel is often band limit. A band-limited channel distributes or spreads through a pulse waveform. Unless the channel bandwidth is considerably greater than the pulse bandwidth, the pulse distribution would be small. The interference occurs in the pulses of the signal, when the channel bandwidth is close to the signal bandwidth and this is called intersymbol interference (ISI)[34]

The multiple paths of signals transmitted from the transmitter are dispersed, scattered, reflected and reflected by (building, trees, and hills) in between receiver and transmitter, because these signals reach in various time and collect on the receiver at various attenuation, delay and with various phase. The signals are constructive or destructive interference due to attenuation and delay, and this is why it is known as a multipath propagation model and this produces more ISI[35]. ISI is a type of signal distortion in which the symbols that follow interfere with one symbol. The presence of ISI in the system, at the receiver output, allows the decision process errors. For example this distortion signal can be seen in figure (3.4)

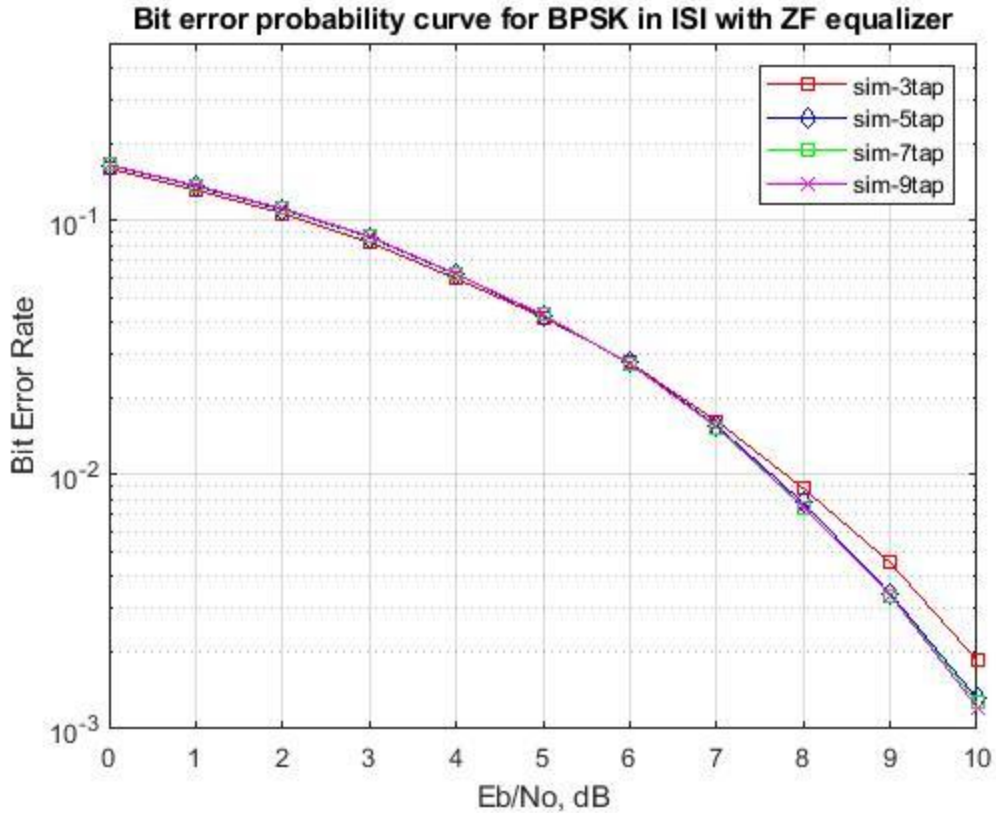

Figure 3.4: Inter symbol interference channel with zero forcing equalizer for BPSK

3.3.2 Inter-Carrier Interference

Regardless of ISI, in the OFDM occurs the channel distortion and non-linearity in the power amplifier and this is the result of the carrier interference (ICI) in addition to the frequency displacement at the receiver and the Doppler Effect. Mostly, on the receiving side, the receiver must be tuned to the same carrier frequency as the carrier signals at the side of the transmitter. However, the frequency of the receiver carrier does not necessarily have to be the same as the frequency of the transmitter carrier due to the influence of many factors. On the transmitter and receiver side, the synchronization is between the carrier frequency and this makes the baseband signals received centralize at the frequency f_c . The frequency difference between the transmit and receive leads to a deviation, and a transmission to $f_c + f\Delta f_c + f\Delta$. As a result, the largest frequency displacement and the largest effect of ICI[36]. As a result of the interference between

the carrier (ICI) and Carrier Frequency Offset (CFO), this leads to poor communication systems efficiency in OFDM. Therefore, attention must be paid to the issue of interference to raise the efficiency of the system. [42] We can see the ICI as shown in figure (2.5) where the error of magnitude use for quantity the performance for transmitter or receiver .

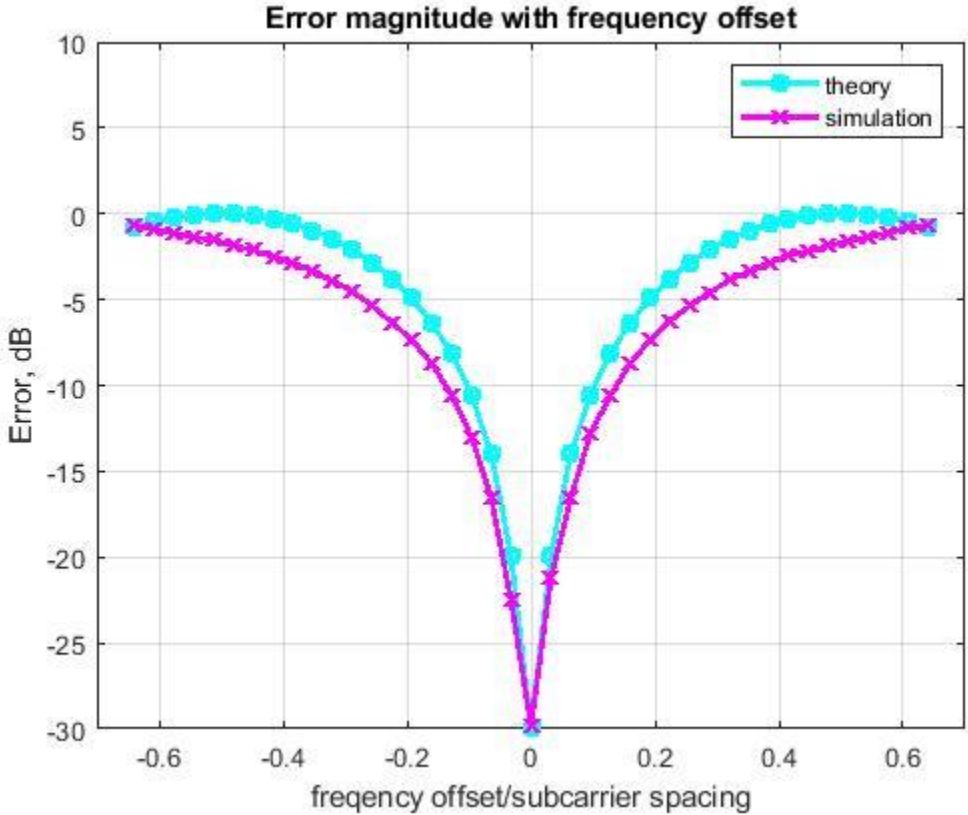

Figure 3.5: Inter-Carrier Interference (ICI) due to frequency offset

3.3.3 Co-Channel Interference

The major problems occur when different frequency ranges are used in the operating standards. Co-channel interference (CCI) is one of those issues that has centered on the cellular communication environment, but not on the radio bands of Industrial, Scientific and Medical (ISM) where numerous heterogeneous wireless systems operate without unified coordination. In

cellular networks, CCI is handled using centralized transmitter power management and scheduling[43] .

Co-channel interference (CCI) is one of the problems with wireless transmitters that use the same frequency, and these are among the problems around the world. [44].Among the other consequences that the interference creates in an unintended way, in particular the DVB-S video broadcast that Ku-Band uses to transmit and receive, this band prevents the weather and this is one of the reasons for the interference with the co-channel [45].

3.4 INTERFERENCES EFFECTS AND CAUSES

We display the effects and cause the interference between three types as shown in table (3.1).

Table 3.1: Effects and causes the interference

NO.	interference	effects	causes
1	Inter Symbol interference	Symbol Delay	Multipath Propagation and Doppler Shift
2	Inter-Carrier Interference	Orthogonally Loses	Carrier Frequency Offset
3	Co-Channel Interference	QoS and BER Degradation	Frequency Reuse

3.5 ADVANTAGES OF OFDM SYSTEM

The advantages of the OFDM transmission As shown below [46][47][48][49]

- ❖ OFDM is computationally efficient to do the modulation and demodulation functions using the FFT techniques.
- ❖ OFDM is more resistant to selective frequency fading in sub-carrier systems, since this is achieved by splitting the channel into flat fading sub-channels on a narrowband.
- ❖ Because of the channel frequency selectivity, missing codes can be restored using the correct channel coding and interleaving.
- ❖ One of the advantages of OFDM is an efficient bandwidth modulation scheme and also has the advantage of ISI mitigation in a selective fading channel.
- ❖ The equation of channels is simpler using single-carrier structures than using adaptive equalization techniques
- ❖ No need to apply channel estimator by coupling differential modulation.
- ❖ OFDM is well protected against impulsive parasitic noise and common channel interference.
- ❖ OFDM can respond to extreme channel conditions without complicating the equalization of the time-domain.
- ❖ Use the cyclic prefix to remove inter-symbol interference (ISI) in OFDM
- ❖ Among the advantages of OFDM is lower sensitivity to timing shift samples than sub-carrier wave systems.
- ❖ OFDM supply big prevention impulse noise and multipath fading.
- ❖ OFDM by permitting overlap the spectrum is used efficiently.
- ❖ OFDM excludes the requirement for equalizers

3.6 DISADVANTAGE OF THE OFDM SYSTEM IS [50][51]

- ❖ OFDM has problems with frequency synchronization.
- ❖ OFDM has problems with Doppler Shift.
- ❖ The OFDM signal has a noise such as amplitude with a wide dynamic range; hence it requires high peak-to - average power ratio (PAPR) and RF power amplifiers.
- ❖ The strong PAPR increases the performance of the converters Analog-to - Digital (A / D), and Digital-to - Analog (D / A).
- ❖ Power amplifiers are less efficient, with a higher PAPR.

3.7 CHALLENGES IN OFDM SYSTEMS

Although OFDM has many advantages in handling wireless communication problems, there are still many problems that need to be resolved.

3.7.1 Carrier Frequency Offset (CFO) and Doppler Effect

One of the main problems that reduce the efficiency of OFDM systems that divide orthogonal frequency is the carrier frequency offset (CFO) [22], receiving data at a different frequency this leads to a Doppler shift in the transmitted frequency. This variance, the result is a violation of the orthogonality of the subcarriers, and this is called the carrier frequency offset (CFO). [23]. This is by CFO induction, due to the transmitter and receiver variance of local oscillator frequencies. Inter-carrier interference (ICI) (is created by interference with one or more adjacent subcarrier [24].

3.7.2 Time Synchronization.

Synchronization is the heart of the OFDM system, based on which it measures the accuracy and timing of error estimation as well as error correction. A very important issue in the study of the OFDM link setup, as the carrier frequency and timing effects, differ on different channels [25]. Timing synchronization problem can be divided into two parts:

Symbol synchronization and sampling clock synchronization. One of the mistakes that result in discovering the start of the symbol is the effect of multiple paths to the wireless channel. The OFDM symbol spreads, causing these errors. This is called inter-symbol-interference (ISI). The displacement of the sampling clock offset to ISI because it causes a drift of the OFDM symbol block away from the FFT reception window. The) ICI (carrier interference creates a result of these two phenomena that lead to the ISI. ISI and ICI are the cause of poor system performance as both undermine the accuracy of the receiver detection system [26].

The BER of the system decreases, leading to system degradation and inter-symbol interference, which is the result of incorrect synchronization [27] generally, two types of timing synchronization are performed: fine timing synchronization and Rough timing synchronization. The timing synchronization in the OFDM system depends on the type of application because the frame structure is not the same in all applications. Short-term communications can be used in some networks, such as wireless local networks, and there are other types of systems in which it is used, Such as the Audio Broadcast / Digital Video device, with several symbols to solve the synchronization problem [28].

3.7.3 Peak to Average Power Ratio (PAPR).

The PAPR of a multi-carrier signal is defined for the ratio of the maximum power to the average signal power transmitted during the data block time, which is the same as the symbol period in

the

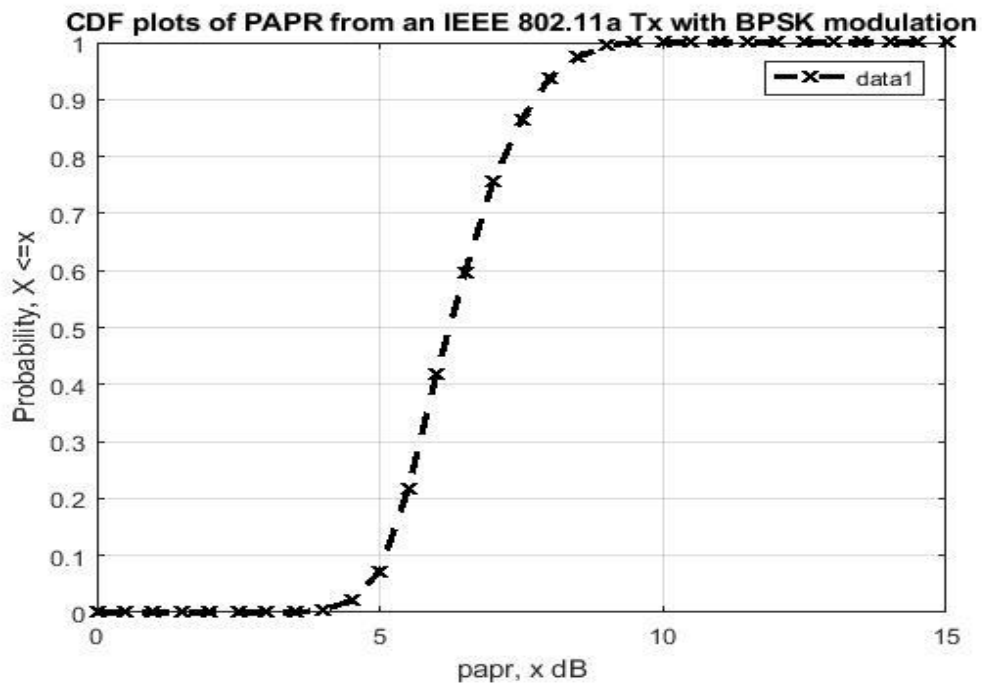

OFDM system. [52] Due to the possibly positive combination of signals in time domain, high PAPR is unavoidable for OFDM signals as a result of multi-carrier transmission, i.e. transmission of multiple signals in parallel [53]. At different phase values they are different with respect to each other at each moment. If all the points reach the same value simultaneously, this will cause the output envelope to increase abruptly, creating a 'peak' in output. The multi-carrier system contains a great number of individually modulated subcarriers, and when they are continuously applied for the purpose of transmission give a high peak value that is very large compared to the sample average. [54] For example, we can see the PAPR in OFDM system for random BPSK modulation signal when the subcarrier = 52 so the maximum PAPR about 17dB for OFDM transmission as show in figure (3-6). and the figure (3.6) for QPSK modulation. To clarify more, we can see an elevation level for PAPR in different modulation BPSK and QPSK when the number of subcarriers = 140, FFT size = 128 and number of symbols = 10^4 . This in figure (3.7)

Figure 3.6: PAPR for a random BPSK signal

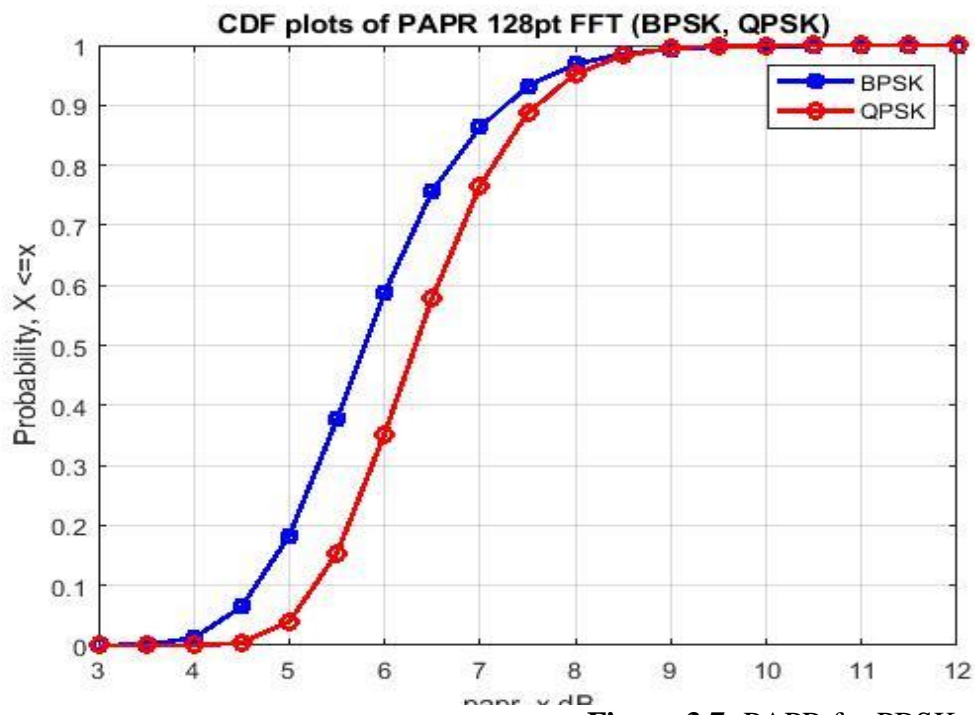

Figure 3.7: PAPR for PBSK and QPSK

4. METHODOLOGY

4.1 OFDM SYSTEM AND PAPR

In an OFDM scheme, the data symbols used by the N orthogonal subcarriers in the transmitter where

$X = [X(0), X(1), \dots, X(N-1)]$ Time domain sequence An OFDM signal can be generated and written as an IFFT.

$$x(n) = \frac{1}{\sqrt{N}} \sum_{K=0}^{N-1} X_K e^{j \frac{2\pi kn}{N}}, \quad n=0, 1 \dots N-1 \quad (4.1)$$

$X(n)$ is the discrete signal for the N orthogonal subcarriers. This is in the time domain, so the OFDM symbol often is that the variations in the envelope will be as of PAPR. Where PAPR is the ratio of the actual signal power to the mean signal power [23].

The OFDM signal series x PAPR is named as

$$PAPR = \frac{\max_{0 \leq n < N} |X(n)|^2}{E[|X(n)|^2]} \quad (4.2)$$

Where $E[\cdot]$ stands for expectation. Complementary cumulative distribution function (CCDF) is used for the calculation value of PAPR level reduction performance in the OFDM system. We may describe the PAPR CCDF to given clip level $PAPR_0$ as

$$CCDF_{PAPR} = \Pr(PAPR > PAPR_0). \quad (4.3)$$

Gaussian time-domain signals of OFDM systems, Can the PAPR CCDF express itself as

$$CCDF_{PAPR} = 1 - (1 - e^{-PAPR_0})^N \quad (4.4)$$

Where N is subcarrier numbers.

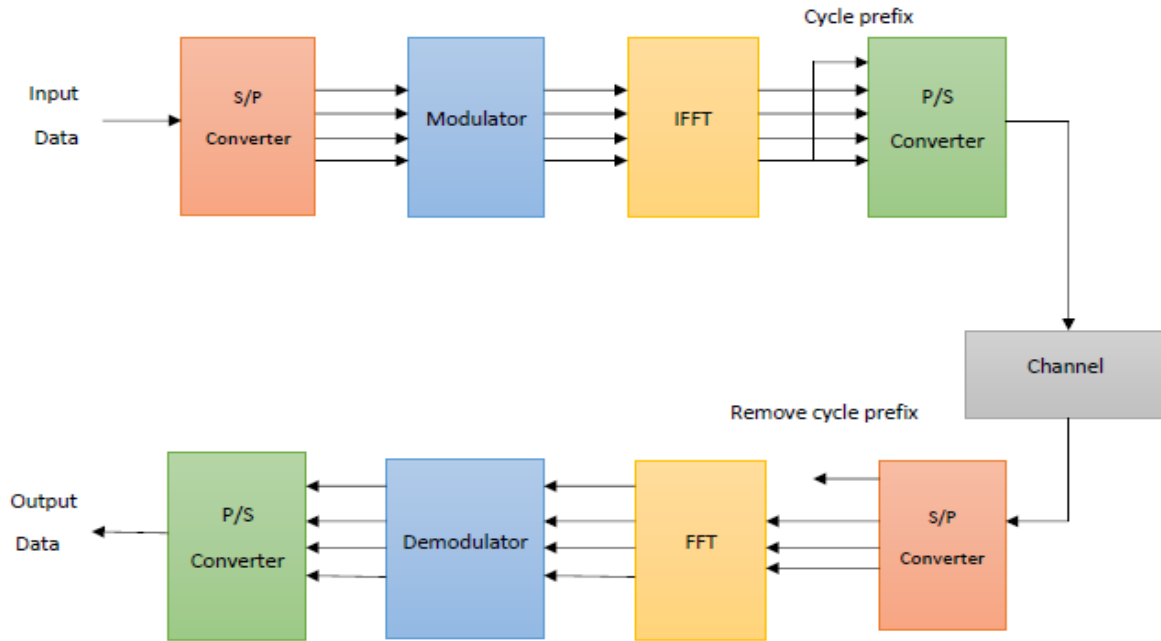

Figure 4.1: OFDM Block diagram Transmitter and Receiver [59]

4.2 PTS SCHEME IN OFDM SYSTEM

A block of symbols In OFDM system

$X = [X(0), \dots, X(N - 1)]^T$ OFDM signal is generated by subcarriers N and N represents the number of subcarriers. The sub carrier generates a set of symbols. The sub-carrier is separated from the adjacent sub-carrier by orthogonality of N when the $\Delta f = 1/T$ where T is the signal duration of OFDM. The OFDM signal is expressed mathematically as follows

$$x(t) = \frac{1}{\sqrt{N}} \sum_{l=0}^{N-1} X(l)e^{j2\pi l\Delta f t}, \quad 0 \leq t \leq T \quad (4.5)$$

X here is a subcarrier vector, for N constellation symbols for ξ constellation, according to Quadrature Phase Shift Keying modulation (QPSK).

The ratio of the maximum instant power to the average power of the OFDM signal is known as the PAPR, and this can be expressed according to the formula.

$$\text{PAPR} = 10 \log_{10} \frac{\max_{0 \leq t < T} |X(t)|^2}{P(av)} \quad (4.6)$$

Sampling of the continuous time signal $X(t)$ produces the separate transmitted signal $X[n]$ and often the Nyquist rate is taken, some information is lost at the height of $X(t)$ and therefore $X[n]$ is exceeded by a factor L to obtain the signal $X(t)$ low value for PAPR. Factor L helps to sequence LN -point data by inserting $N(L-1)$ zeros in the center of the N -point frequency domain signal and this is by LN -point IFFT and this gives IFFT which can be expressed as follows:

$$x[n] = \frac{1}{\sqrt{LN}} \sum_{l=0}^{LN-1} X(l) e^{j2\pi ln/N} \quad 0 \leq n \leq LN-1 \quad (4.7)$$

Where $X = [X(0), \dots, X(N/2 - 1), \underbrace{0, \dots, 0}_{(L-1)N}, X(N/2), \dots,$

$X(N-1)]$. It is shown $L=4$ enough to take the peak of the information $X(t)$ [27].

The disjointed M sub block are the result of dividing the input data block into X and this relationship can be represented by vectors according to the equation below and this is in the PTS system to reduce PAPR in OFDM: $\{X_m, m = 1, 2, \dots, M\}$. Therefore, we can get

$$X = \sum_{m=1}^M X_m \quad (4.8)$$

The sum of the sub-blocks must be zero for the original signal which is displayed in another block, and this leads to a partial transmission sequence in the time domain M as a result of the transformation of the sub-blocks X_m X and this relationship can be represented as

$$X_m = IFFT_{LN \times N}\{X_m\} \quad (4.9)$$

By incorporating phase factors $P = [P_1, P_2, \dots, P_m]$ this results in a group of candidates and this is after PTS rotated independently this can be represented as:

$$\bar{x} = \sum_{m=1}^M P_m x_m = \sum_{m=1}^M IFFT\{P_m \odot X_m\} \quad (4.10)$$

It is possible to observe the special chart No. (3.2) for C-PTS and to know that the choice of the candidate with the lowest PAPR is by searching the previous candidate for transmission, as for how to retrieve the original symbol X is by sending the side information bits to indicate the improved phase sequence and then to the receiver

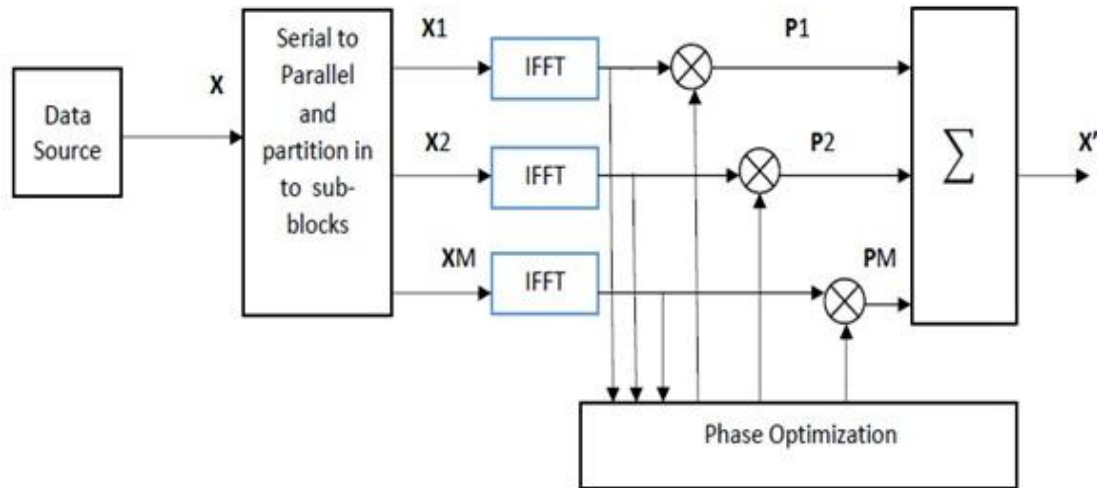

Figure 4.2: Block diagram Of PTS [58]

4.3 NUMBER THEORY

Number theory is a branch of pure mathematics mainly dedicated to studying the integral functions and integer. German mathematician Carl Friedrich Gauss (1777–1855) said: "The Queen of Sciences is arithmetic — and the Queen of Arithmetic is the theory of numbers[55]. Polygon numbers type of Number theory. The diagrams figure (4.3) show how polygon numbers are geometrically constructed. The illustrated polygonal numbers are respectively called “triangular, square, pentagonal, and hexagonal and centered counterparts [56]. In the proposed algorithm, we took advantage of this theory in preventing data similarities and reducing the value of PAPR. According to this theory, the numbers of polygons are characterized by their preventing similarity, and this leads to sequence similarities being prevented. This feature makes us think about applying it to our work to reduce the PAPR.

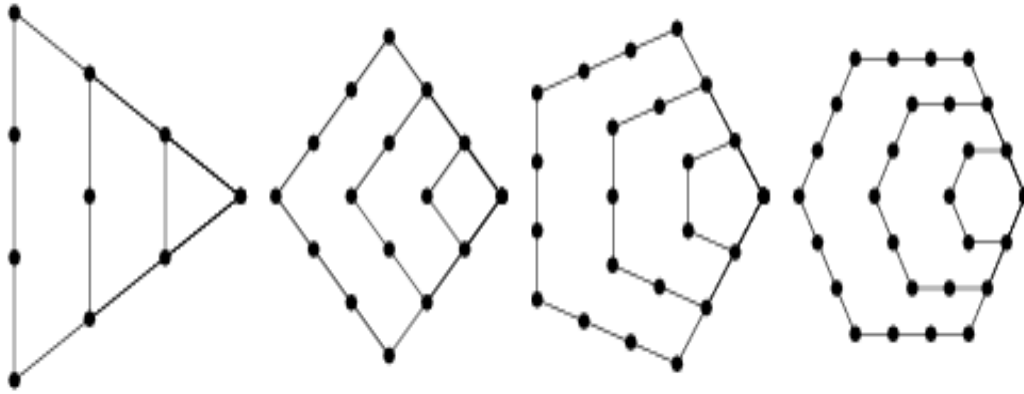

Figure 4.3: Type of polygon number triangular, square, pentagonal, and hexagonal [57]

4.3.1 Polygon Numbers:

A closed plane figure consisting of multiple segments of line that are joined together. The sides do not overlap one another. Two sides meet exactly on each vertex. They are called figurate numbers, since regular geometric arrangements of uniformly spaced points may reflect them. Examples of Polygonal numbers include the triangular number so, the polygonal number is a type of figurate number that is a generalization of triangular, square, pentagon numbers, etc. The polygonal centered numbers are a less possibly the best-known family of figurative, this time generated by arranging points into a sequence of nested polygons of increasing size with a common center. To clear that let $K \geq 3$ Denote how many sides a polygon has and $P_k(r)$ and $P_k(q)$ the r th k polygonal and q th k centered polygon number, for $r, q \geq 1$.diagrams above demonstrate graphically the mechanism by which the polygonal numbers are formed.[57]

4.3.2 Polygon Formulas:

(N = both sides, and S = middle to corner length)

Standard polygon area = $(1/2) N \sin (360^\circ / N) S^2$;

Inside angles sum of a polygon = $(N-2) \times 180^\circ$

Diagonal numbers in a polygon = $1/2 N (N-3)$

Number of polygon triangles = $(N-2)$ (when you draw all the diagonals from a single vertex). Now we starting with the n th triangular number T_n .

$$n + T_{n-1} = T_n.$$

$$\Delta n = 1 + 2 + 3 \dots + n = \frac{1}{2} n(n + 1) \tag{4.11}$$

Now look for

$$n + 2 T_{n-1} = n^2 = S_n \text{ Gives the number } n\text{th square} \tag{4.12}$$

$$n + 3 T_{n-1} = \frac{1}{2} n (3 n - 1) = P_n, \text{ Gives the number } n\text{th pentagonal ,} \tag{4.13}$$

And so on. The general number of polygons can be written as

$$P_n^r = \frac{1}{2} n [(n - 1) r - 2 (n - 2)] \tag{4.14}$$

$$= \frac{1}{2} n [(r - 2) n - (r - 4)], \tag{4.15}$$

Where P_n^r is the n th r -gonal number (Savin 2000). To more clear if we take example, taking $n = 3$ in (5) gives a triangular number, $n = 4$ gives a square number, etc.

4.3.3 Calculation of Polygon Numbers:

Let $P (m,n)$ be the n th value for the number of m -sided polygons.

So, the third square number is $P (4, 3)$, that is to say, 9. $P (5, 6)$ is the sixth number on the pentagon. For example, the n th square number is given by:

$$P (4, n) = 1 + 3 + \dots + (2n - 1)$$

This sum can be determined simply by multiplying the number of terms by the mean value of the terms.

So we get $P (4, n) = n (2n-1 + 1)/2 = n^2$.

We can extend that method to obtain:

$$P(m, n) = 1 + (m - 1) + \dots + [(m - 2)n - (m - 3)]$$

The last term needs some enquiry and is left to the reader. If we multiply the number of terms by the mean value of the terms, we get:

$$P(m, n) = \frac{1}{2} n [(m - 2)n - (m - 3)] = \frac{n}{2} [(n - 1)(m - 2) + 2] \quad (4.16)$$

For explain further the work of these three groups, we present a table below showing the characteristics of each of these numbers

Table 4.1: characteristics of Polygons Number

Polygons	Sides	No.Of Angle	No.Of Vertices	No.Of Diagonals
Triangle	3	3	3	0
Pentagon	5	5	5	5
Hexagon	6	6	6	9

5. THE PROPOSED METHOD

In this method, the geometric shape theory of numbers was used, and three sets of numbers 3, 5, 6, triangular, pentagonal and hexagonal numbers were used. The following are the stages that have been implemented in applying this algorithm on the conventional scheme:

- 1- Polygon number theory for the numbers 3, 5, 6: three types of groups have been taken, and these groups of numbers are not equal if N is equal, as they depend on the geometry of the number. Below are the equations that were used in this proposed method in the form of each of these numbers:

$$t_n = \frac{1}{2} n (n+1) \tag{5-1}$$

$$P_n = \frac{1}{2} n (3n+1) \tag{5-2}$$

$$h_n = n (2n-1) \tag{5.3}$$

Where t_n triangular number, P_n pentagonal number, h_n hexagonal number

We took advantage of this feature in the input data when sending it, when this feature is highlighted on the input data, it prevents similar data. For example, when three consecutive values come one after the other equal in value, and when multiplying each of these equal values by a number from the group chosen (3, 5, 6) the result of these numbers will be unequal

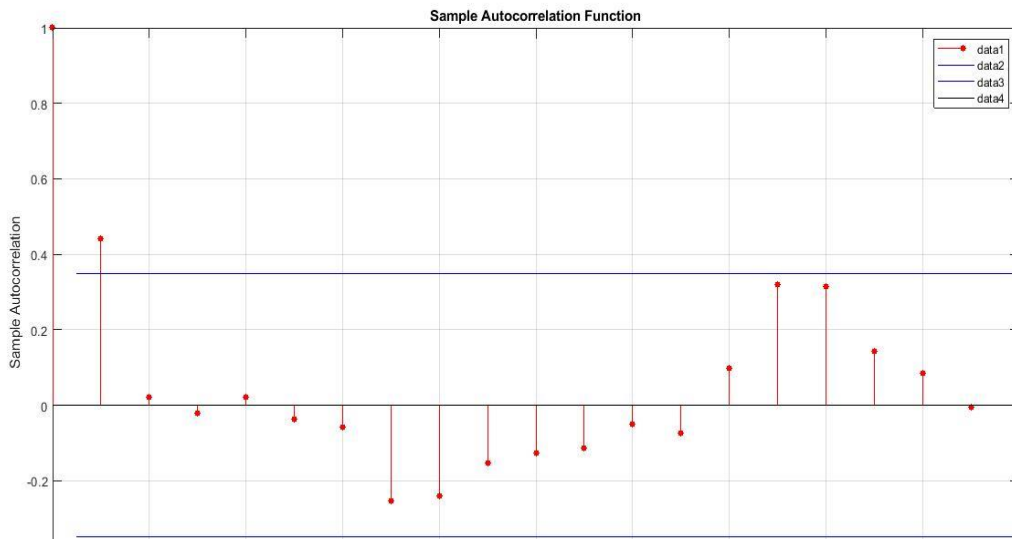

Figure 5.1: Input sequent numbers Different values

according to the succession property. This can be seen in Figure (5.1) (5.2). In this drawing we took a group of different numbers and some of these numbers are equal in value and applied to it polygon number algorithm, we have dissimilar values. And we notice in Figure (5.3) the amount of fluctuation that occurred due to similarities in numbers and how they are processing

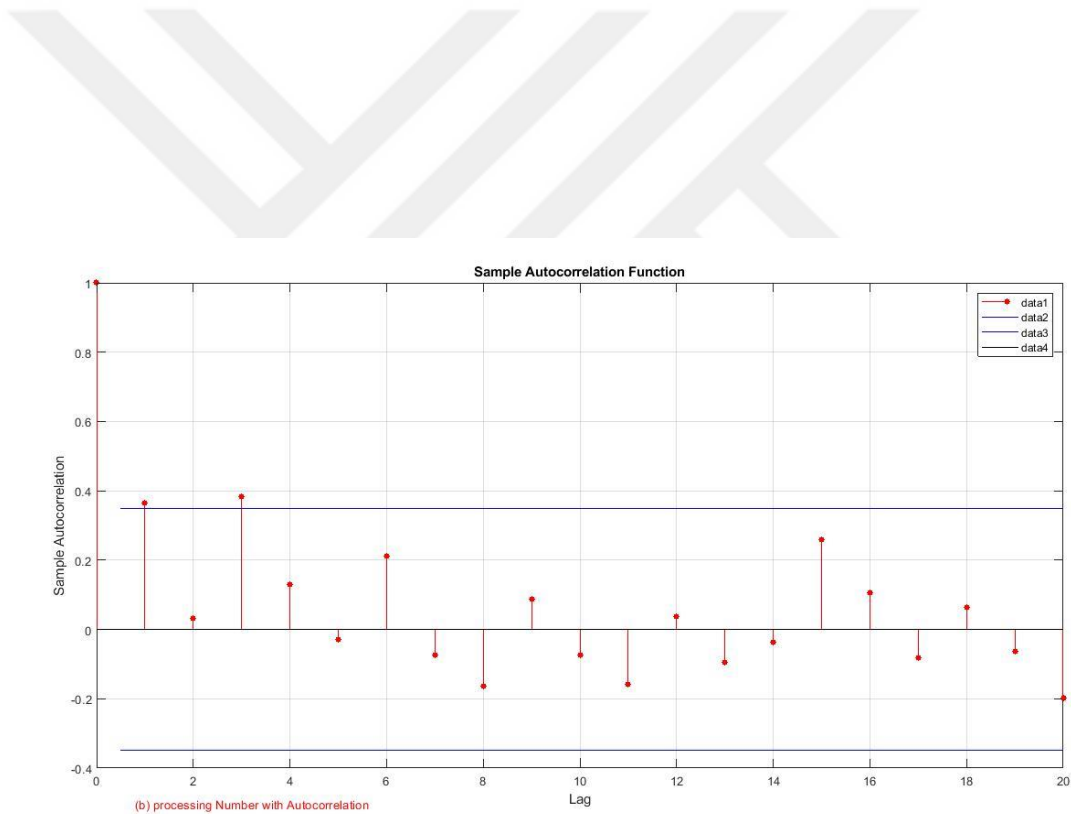

Figure 5.2 : processing Number with Autocorrelation

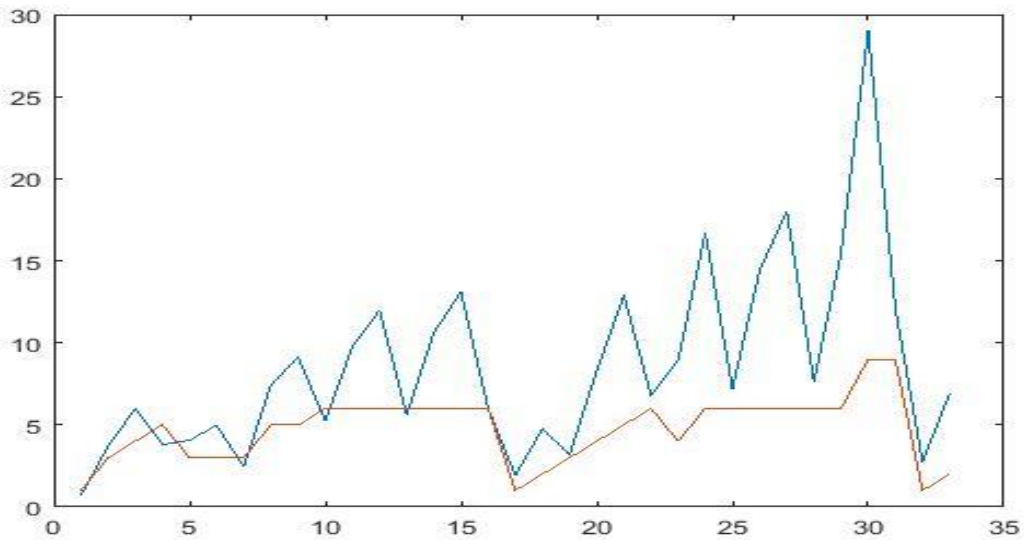

Figure 5.3: Autocorrelation with Different values

2- After knowing the effect of the theory on the similar numbers, we made an experiment of the effect of the increase in the shape of these three groups when increasing the value. This increase can be observed according to Figure (5.4), where the amount of change that occurs when changing the value of each of these groups is shown to us in Figure (5.5).

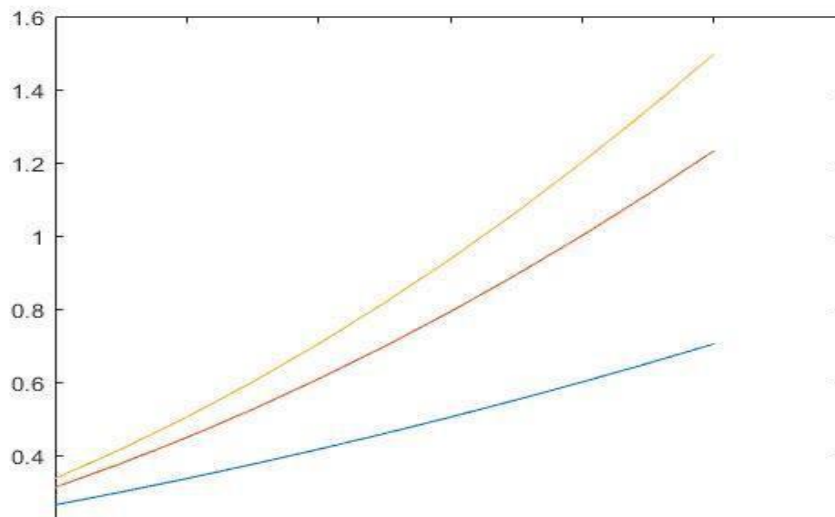

Figure 5.4: The Effect of the increase over 3 groups same groups

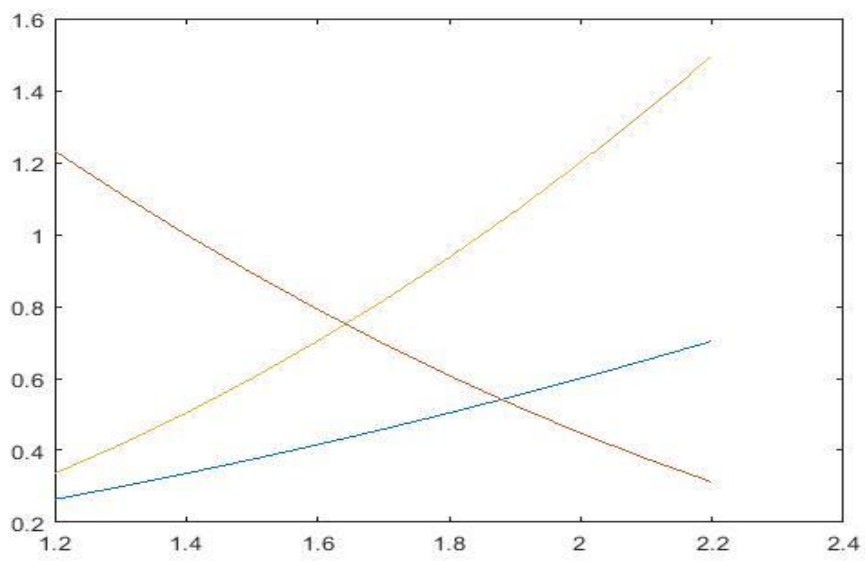

Figure 5.5: The Effect of the increase over 3 groups change the pentagonal with different groups

3- In this step, we made an experiment of a set of periods, which were divided into 10 values. After that, we chose a specific period from these periods, which is the selection of a portion of the above-mentioned schemes, where we began to experiment with a period of (1.2-202) and another (2.2-3.2), etc., meaning that the amount of the increase is 1, and we noticed that there was no big difference when changing these values between one group and another. This confirms to us the increase in fluctuation that was mentioned in the previous clause, which was processed in the similarity of data. Figures (5.6, 7, 8, and 9) shows these periods taken.

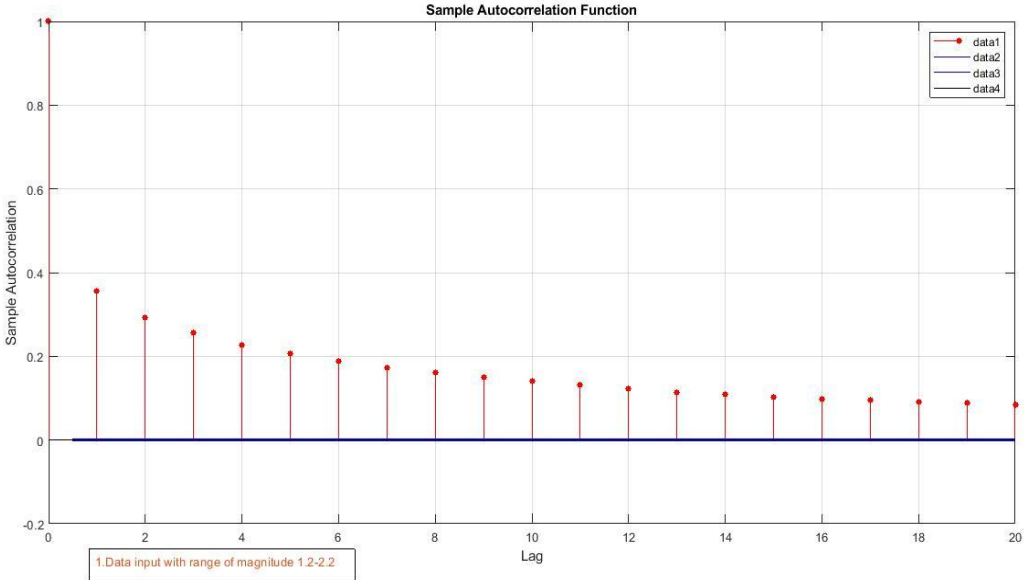

Figure 5.6: Data input with range of magnitude 1.2-2.2

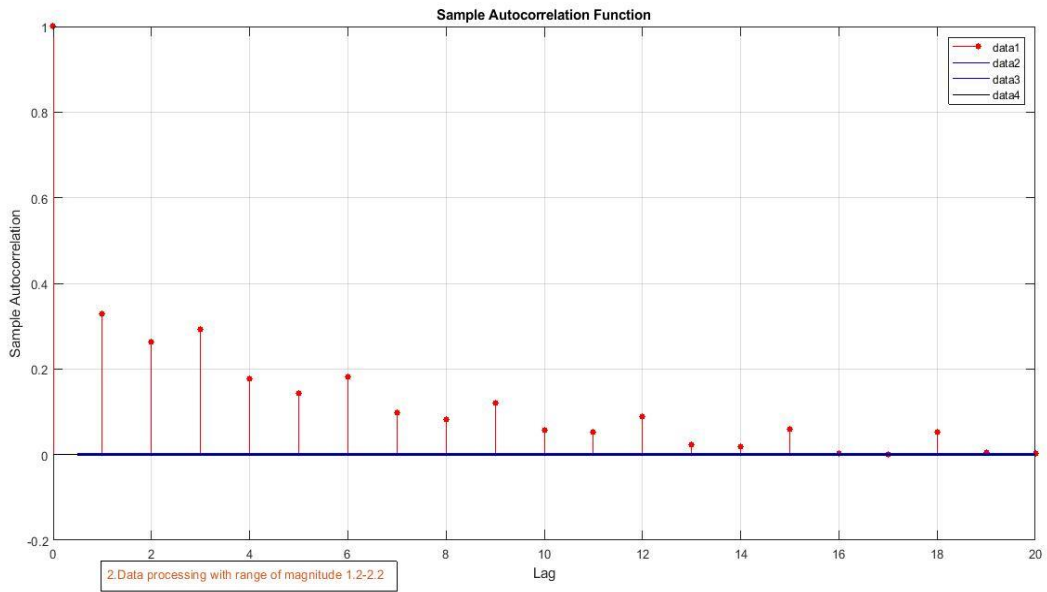

Figure 5.7: Data processing with range of magnitude 1.2-2.2

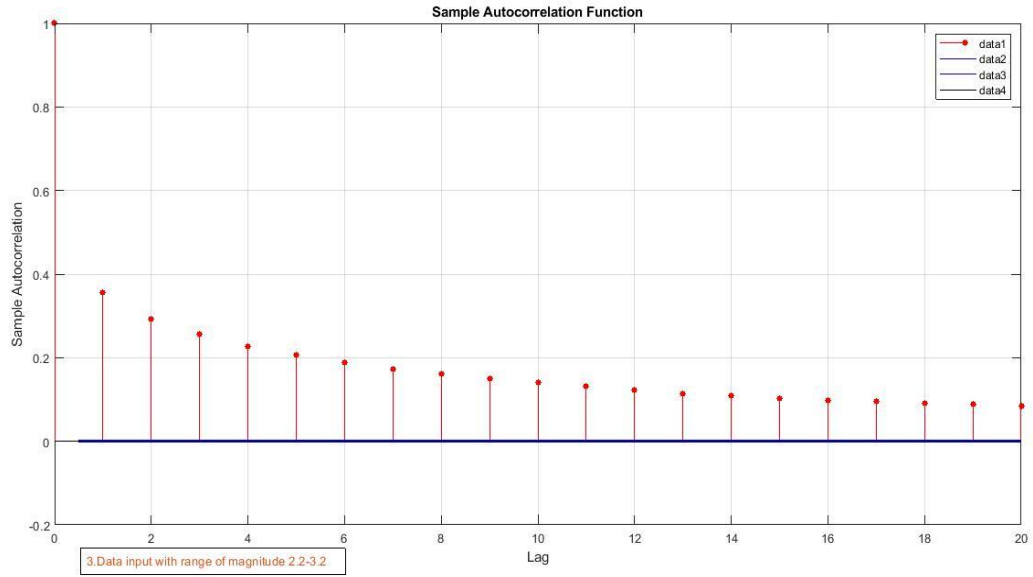

Figure 5.8: Data input with range of magnitude 2.2-3.2

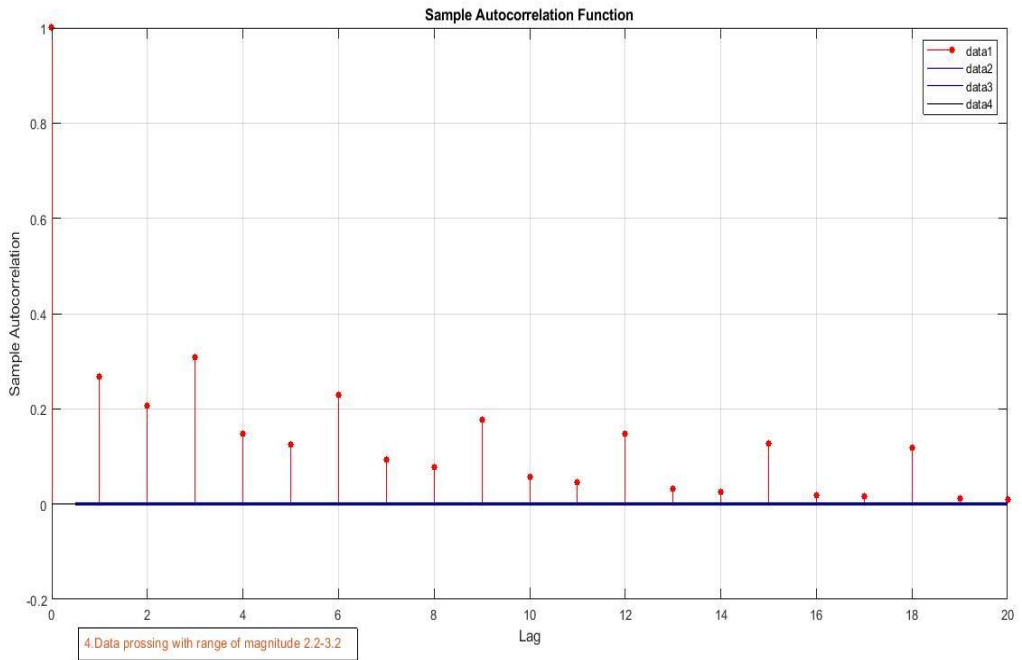

Figure 5.9: Data processing with range of magnitude 2.2-3.2

For example, if we wanted to see the type of data in the proposed system, how it is processed according to the number of the polygons, we would include below the form of data that was tried

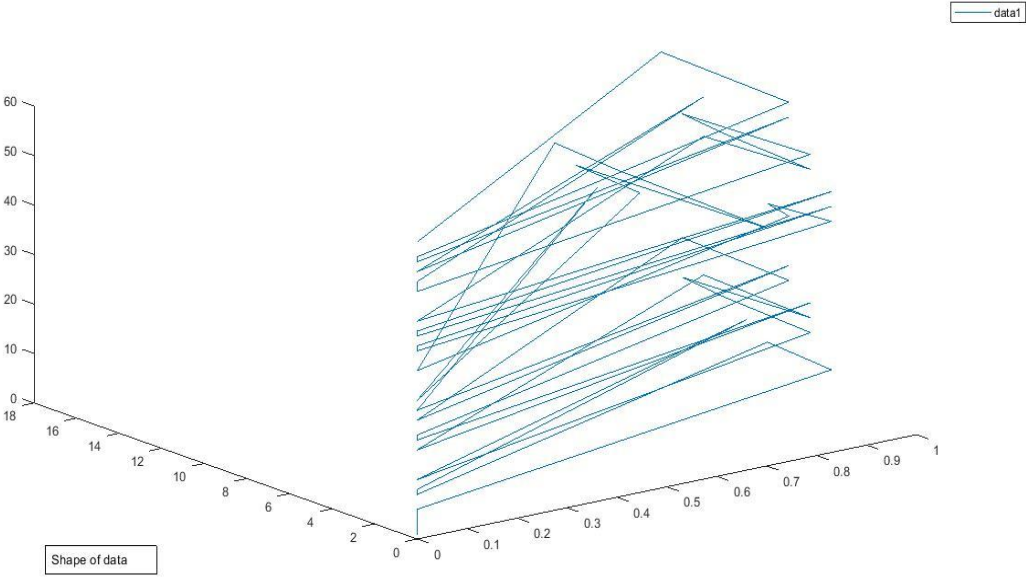

Figure 5.10: Shape of the data input with Polygon Number

on the data entered as shown in figure(5.10).

The figures above shows us how to process similar data at different periods, and it is clear from the figures that despite the fluctuation, it happens in all periods, but it differs in values. So, in order to avoid amplifying the signal, we will choose one group over an average period for the rest of the work, which is (3.2-2.2).

- 4- After studying the effect of periods on data fluctuation and to prevent amplification, the pentagonal number group was reversed as shown in the figure (5.4). For the purpose of indicating the mechanism for the work of this algorithm by the proposed method, this can be observed through scheme (5.11), where this algorithm works on the principle of the inequality of the three values that were taken when the value of N is equal and that we

have previously said this is according to the succession feature based on the geometry of the numbers, the data that contains a similar set of data that we shed on this algorithm to prevent similarity of the transmitting moment. In order to prove that, we have experimented with the proposed method of (C-PTS) after the data was entered from the source for the purpose of transmission. We shed these data on the proposed algorithm, which can be observed its sequence of this method as in Figure (5.12) where the data is entered on the algorithm and then this algorithm alternately changes similar values to different values. The data generated is considered to be encrypted data and the resulting data is ready for the purpose of the transmission process according to the conventional method steps in PTS shown in Figure (5.13). Upon receipt, decryption is made to obtain the original data.

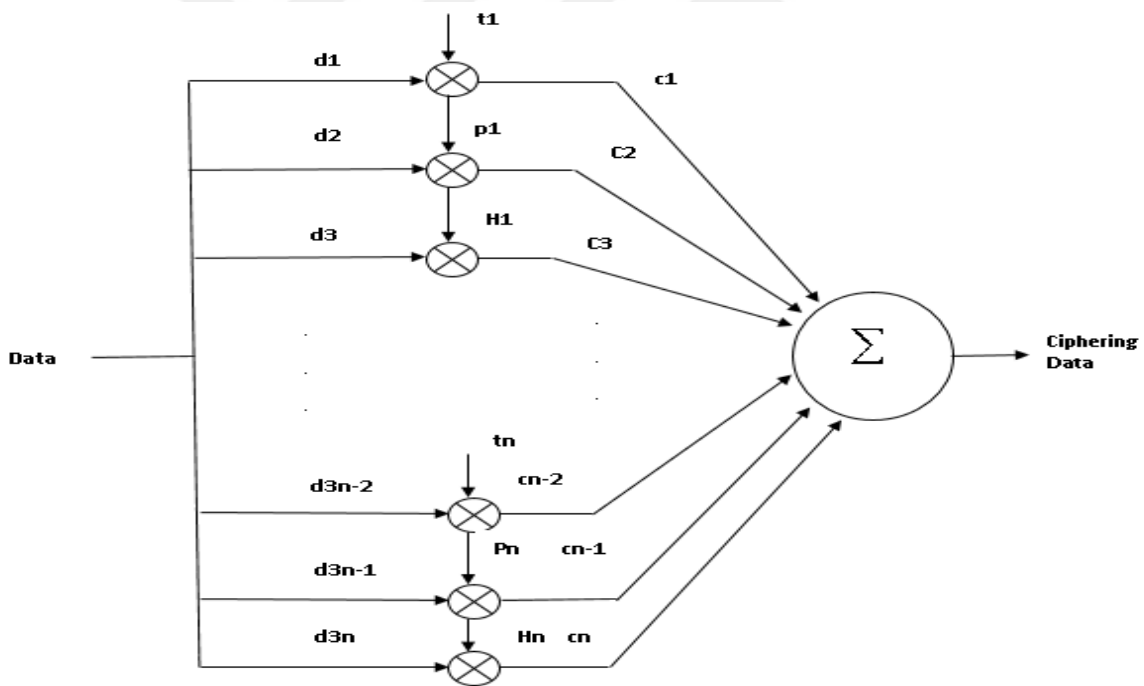

Figure 5.11: proposed algorithm

Figure 5.12: Processing the data input with the proposed method

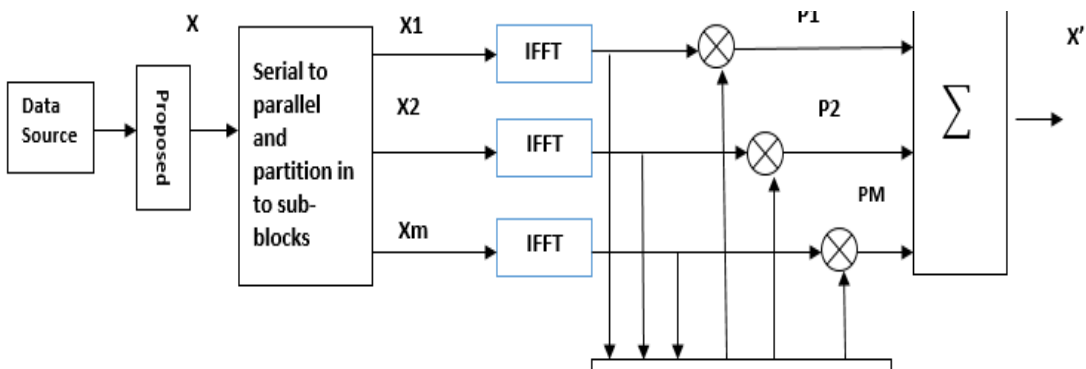

Figure 5.13: Block diagram of the proposed method with C-PTS scheme

In the (5.13) is the figure showing the proposed method that was applied to (C-PTS) method, as the old method characteristics that were mentioned in the previous paragraph were used. PTS was modified for the purpose of improving the PAPR. And when reviewing the work of the old method on which the proposed method has been applied the first block of the drawing is the source of data input in the OFDM system represented by the sequence of the input code in the X vector that is synthesized by the subcarrier after the generated data is entered on the proposed block method, the result from it is entered on the part that converts the input data into Group M from the separate sub-blocks:

$$X_m, 1 \leq m \leq M.$$

Then the time field signal is converted to IFFT multiplied by the phase factors, After that we get the OFDM, and then pick the best X signal with the lowest PAPR point.



6. SIMULATION RESULTS

In this research litter we used the Matlab simulation program which explains the results of the proposed method and its effect on the previous method. The first table includes the most important variables that were used in the simulation program that represent the proposed method in which PTS was improved in reducing the PAPR.

Table 6.1: Parameters of the Simulation

Parameter	Value
Number of OFDM signal	10000
Number of subcarrier N	64
Modulation	4,16 ,32, 64 QPSK
IFFT&FFT size	256
oversampling factor(L)	4
Number of partitions p	4

In Figure (6.1) it shows the performance of the proposed approach and the PAPR reduction level when the subcarrier is $N = 64$ and the OFDM signal number = 1000. The experiment was carried out up to 10,000 QPSK signals. The results of the proposed method can be seen in Table (2), which shows the amount of improvement in reducing the PAPR between C-PTS and the proposed method

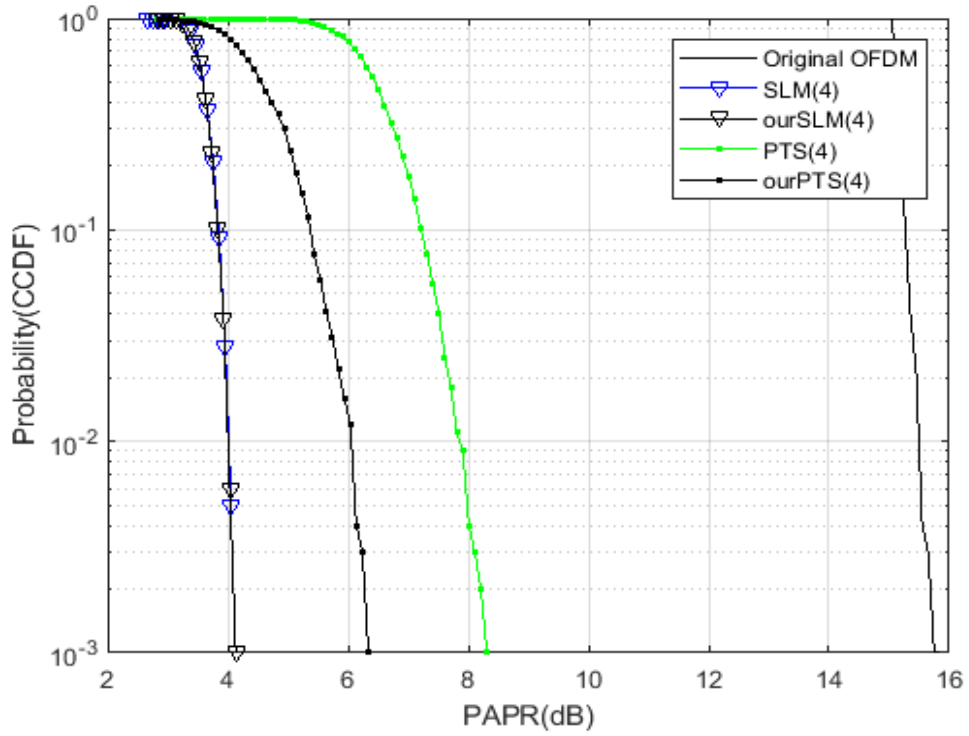

Figure 6.1: PAPR performance of proposed scheme with C-PTS and SLM schemes for 4 QPSK

Table 6.2: Computational the complexity between the proposed and conventional schemes with different No.subbands

N=8					
No.of OFDM signal	Original signal in dB	C_PTS	P-PTS	Old SLM	New SLM
1000	15.1263	6.4068	4.6961	3.5609	3.5526
10000	15.1287	6.3157	4.6826	3.5609	3.5526
N=32					
No.of OFDM signal	Original signal in dB	C_PTS	P-PTS	Old SLM	New SLM
1000	15.1342	6.4473	4.7059	3.5609	3.5526
10000	15.1288	6.4169	4.7125	3.5609	3.5526
N=64					
No.of OFDM signal	Original signal in dB	C_PTS	P-PTS	Old SLM	New SLM
1000	15.1268	6.4376	4.5683	3.5609	3.5526
10000	15.1379	6.4503	4.7205	3.5609	3.5526

In Figure (6.2, 3, and 4), the diagram shows the types on which the algorithm was tried, as more than one type of QPSK modulation was used, Where the results of the simulation indicated that the work of the proposed method always improved the value of PAPR Compared with scheme C-PTS. The results of the scheme can be seen in Table No. (6.3).

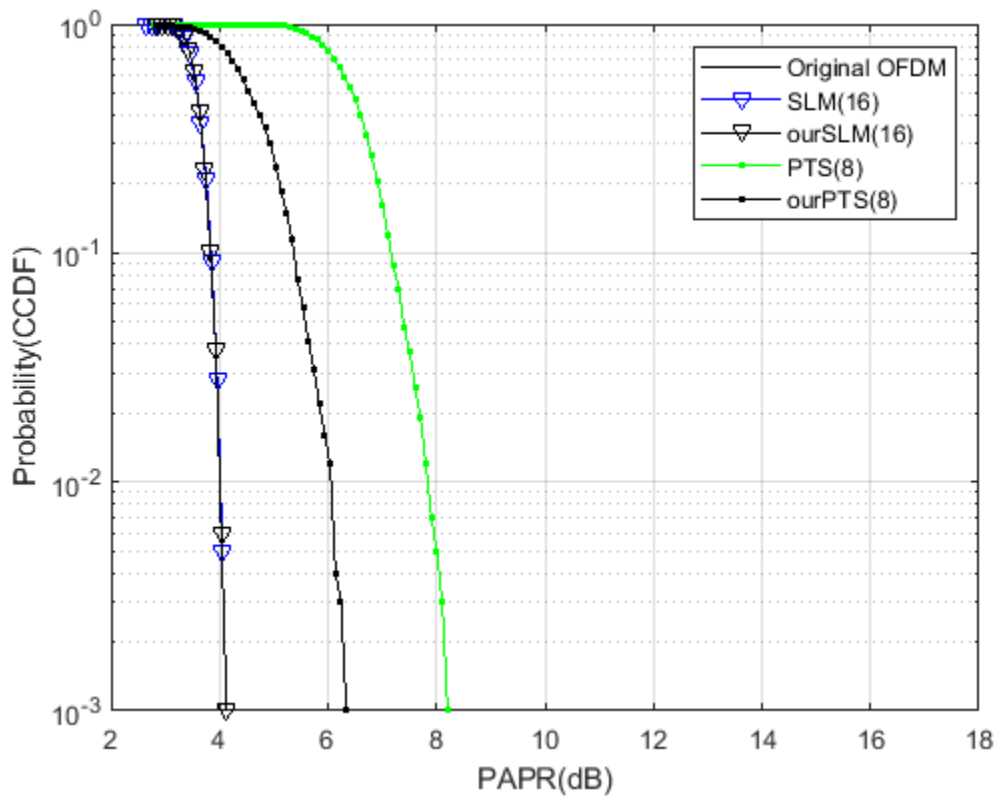

Figure 6.2: PAPR performance of proposed scheme with C-PTS and SLM schemes with $N=8$

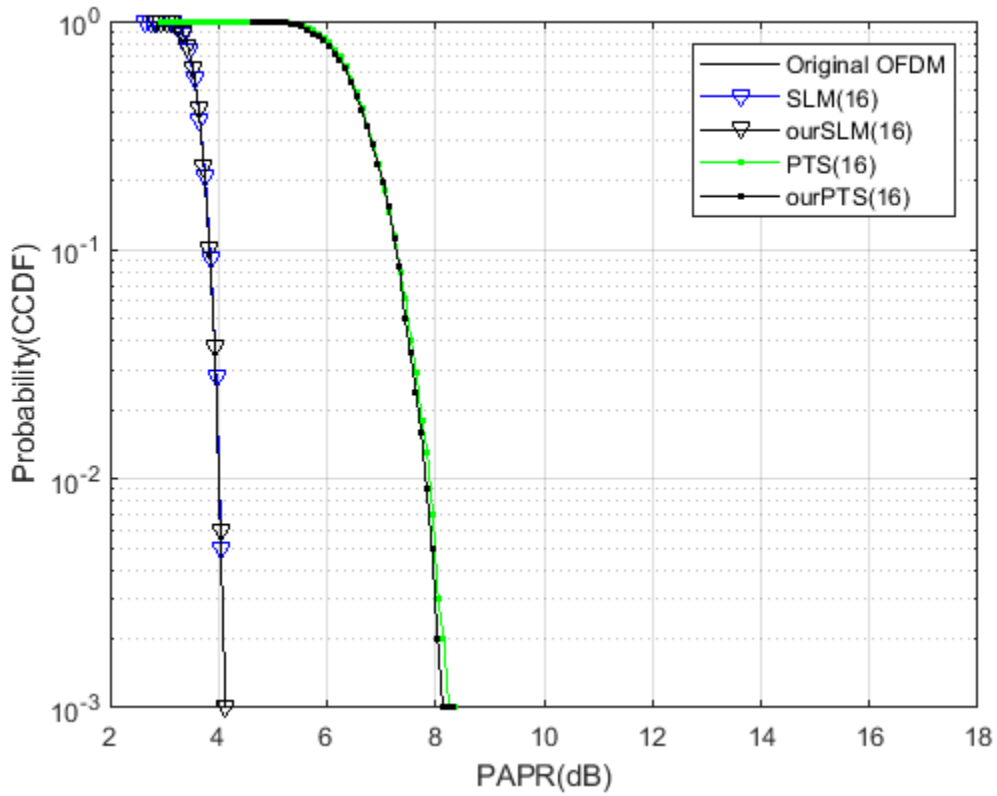

Figure 6.3: PAPR performance of proposed scheme with C-PTS and SLM schemes with 16 QPSK



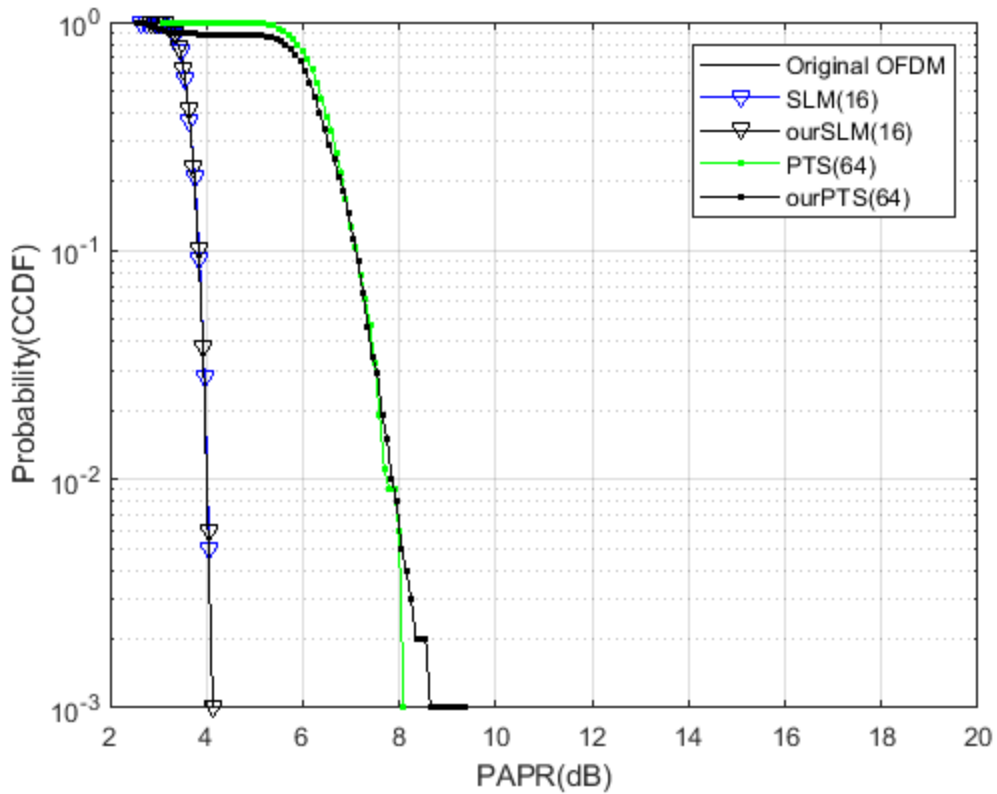

Figure 6.4: PAPR performance of proposed scheme with C-PTS and SLM schemes with 64 QPSK

Table 6.3 : Computational the complexity between the proposed and conventional scheme with different modulation

QPSK modulation	Original signal in dB	C_PTS	P-PTS
4	15.1268	6.4376	4.5683
8	15.1272	6.3297	4.8872
16	12.4691	6.3651	4.8704
64	15.1380	6.3612	5.9610

7. CONCLUSION AND FUTURE WORK

7.1 THESIS SUMMARY:

In this thesis, we presented the basics of communication, specifically the OFDM and a historical analysis of how relations grow from generation to generation. The most important challenges facing researchers working in this field is efficiency of power and maximum power to send and received signal, this in **Chapter 1**. we provided a research overview in **Chapter2**, covering the reduction PAPR schemes .Then we talk on the principle of digital communication system and discussed the most important challenges of OFDM systems, advantage and disadvantage, such as has problems with frequency synchronization, Doppler Shift and high Peak-to-Average Power Ratio (PAPR) and we have chosen one of the biggest problems that many researchers seek to reduce, which is high PAPR in **Chapter3**. After that. Then we discussed the methodology of the conventional PTS method and the proposed method in **Chapter4**. A new algorithm used to reduce height PAPR this method has helped to reduce most of the elevation level of PAPR, in **Chapter5**. In **Chapter 6**. Result of simulation of proposed system. Finally, conclusion of the research. In this research letter we have proposed a new way to reduce the PAPR in the system of OFDM. The new method used was based on the polygon number theory, as this algorithm was applied to the C-PTS method, which prevented similar data at the time of transmission. This has improved transmission since it prevents the transmission of side information and reduces the rise in the PAPR. In addition, among the characteristics of this proposed algorithm is that it is easy to encrypt and easy to decrypt in returning data for the purpose of transmission. Moreover, the proposed method reduced the high level of PAPR in the conventional (C-PTS) method. There is a slight decrease in the PAPR level of the SLM method.

7.2 FUTURE WORK:

It is possible in the future to apply this algorithm to other methods such as 'rotating phase shift technique'. Moreover, it can be applied to other systems that are an alternative for the OFDM system, which researchers are seeking to discover an alternative, particularly in the implementation of the 5G of the communication system.



REFERENCES

- [1] Y. G. Li and G. L. Stuber, *Orthogonal frequency division multiplexing for wireless communications*. Springer Science & Business Media, 2006
- [2] R. Prasad, *OFDM for wireless communications systems*. Artech House, 2004.
- [3] M. A. Abu-Rgheff, *Introduction to Digital Communications*. 2007.
- [4] J. W. Leis, *Communication systems principles using MATLAB*. John Wiley & Sons, 2018.
- [5] G. Farahani, “Autocorrelation-based noise subtraction method with smoothing, overestimation, energy, and cepstral mean and variance normalization for noisy speech recognition,” *Eurasip J. Audio, Speech, Music Process.*, vol. 2017, no. 1, 2017.
- [6] A. Lahcen, A. Kamal, H. Mustapha, E. Ali, A. Saida, and A. Adel, “Peak-to-Average Power Ratio Reduction Using New Swarm Intelligence Algorithm in OFDM Systems,” *Procedia Manuf.*, vol. 32, pp. 831–839, 2019.
- [7] A. A. Sharif and M. Hosseinzadeh Aghdam, “A novel hybrid genetic algorithm to reduce the peak-to-average power ratio of OFDM signals,” *Comput. Electr. Eng.*, vol. 80, p. 106498, 2019.
- [8] L. Yang, K. K. Soo, S. Q. Li, and Y. M. Siu, “PAPR reduction using low complexity PTS to construct of OFDM signals without side information,” *IEEE Trans. Broadcast.*, vol. 57, no. 2 PART 1, pp. 284–290, 2011.
- [9] X. Zhu, W. Pan, H. Li, and Y. Tang, “Simplified approach to optimized iterative clipping and filtering for PAPR reduction of OFDM signals,” *IEEE Trans. Commun.*, vol. 61, no. 5, pp. 1891–1901, 2013.
- [10] H. Liang, “Combining block-coded modulation codes and improved constellation extended schemes to reduce peak-to-average power ratio in orthogonal frequency-division multiplexing systems,” *IET Commun.*, vol. 6, no. 16, pp. 2705–2714, 2012.

- [11] E. Alsusa and L. Yang, "A low-complexity time-domain linear symbol combining technique for PAPR reduction in OFDM systems," *IEEE Trans. Signal Process.*, vol. 56, no. 10 I, pp. 4844–4855, 2008..
- [12] R. Rajbanshi, A. M. Wyglinski, and G. J. Minden, "OFDM-based cognitive radios for dynamic spectrum access networks," *Cogn. Wirel. Commun. Networks*, pp. 165–188, 2007.
- [13] H. L. Hung and Y. F. Huang, "Peak-to-average power ratio reduction in orthogonal frequency division multiplexing system using differential evolution-based partial transmit sequences scheme," *IET Commun.*, vol. 6, no. 11, pp. 1483–1488, 2012.
- [14] M. Bala, M. Kumar, and K. Rohilla, "PAPR reduction in OFDM signal using signal scrambling techniques," *Int. J. Eng. Innov. Technol.*, vol. 3, no. 11, pp. 140–143, 2014.
- [15] H. S. Joo, K. H. Kim, J. S. No, and D. J. Shin, "New PTS Schemes for PAPR Reduction of OFDM Signals Without Side Information," *IEEE Trans. Broadcast.*, vol. 63, no. 3, pp. 562–570, 2017
- [16] H. Chen and K. C. Chung, "A low complexity PTS technique using minimal trellis in OFDM systems," *IEEE Trans. Veh. Technol.*, vol. 67, no. 1, pp. 817–821, 2018
- [17] K. S. Lee, H. Kang, and J. S. No, "New PTS Schemes with Adaptive Selection Methods of Dominant Time-Domain Samples in OFDM Systems," *IEEE Trans. Broadcast.*, vol. 64, no. 3, pp. 747–761, 2018.
- [18] Z. Zhou, L. Wang, and C. Hu, "Low-Complexity PTS Scheme for Improving PAPR Performance of OFDM Systems," *IEEE Access*, vol. 7, pp. 131986–131994, 2019.
- [19] J. Y. Woo, H. S. Joo, K. H. Kim, J. S. No, and D. J. Shin, "PAPR analysis of class-III SLM scheme based on variance of correlation of alternative OFDM signal sequences," *IEEE Commun. Lett.*, vol. 19, no. 6, pp. 989–992, 2015.
- [20] N. Taspinar and M. Yildirim, "A Novel Parallel Artificial Bee Colony Algorithm and Its PAPR Reduction Performance Using SLM Scheme in OFDM and MIMO-OFDM Systems," *IEEE Commun. Lett.*, vol. 19, no. 10, pp. 1830–1833, 2015.

- [21] D. J. G. Mestdagh, J. L. G. Monsalve, and J. M. Brossier, "GreenOFDM: A new selected mapping method for OFDM PAPR reduction," *Electron. Lett.*, vol. 54, no. 7, pp. 449–450, 2018.
- [22] M. I. Al-Rayif, H. Seleem, A. Ragheb, and S. Alshebeili, "A Novel Iterative-SLM Algorithm for PAPR Reduction in 5G Mobile Fronthaul Architecture," *IEEE Photonics J.*, vol. 11, no. 1, pp. 1–12, 2019.
- [23] J. Wang, X. Lv, and W. Wu, "SCR-Based Tone Reservation Schemes with Fast Convergence for PAPR Reduction in OFDM System," *IEEE Wirel. Commun. Lett.*, vol. 8, no. 2, pp. 624–627, 2019.
- [24] K. Anoh, C. Tanriover, B. Adebisi, and M. Hammoudeh, "A New Approach to Iterative Clipping and Filtering PAPR Reduction Scheme for OFDM Systems," *IEEE Access*, vol. 6, pp. 17533–17544, 2017.
- [25] B. Tang, K. Qin, X. Zhang, and C. Chen, "A Clipping-Noise Compression Method to Reduce PAPR of OFDM Signals," *IEEE Commun. Lett.*, vol. 23, no. 8, pp. 1389–1392, 2019.
- [26] X. Liu, X. Zhang, J. Xiong, F. Gu, and J. Wei, "An Enhanced Iterative Clipping and Filtering Method Using Time-Domain Kernel Matrix for PAPR Reduction in OFDM Systems," *IEEE Access*, vol. 7, pp. 59466–59476, 2019.
- [27] B. Tang, K. Qin, H. Mei, and C. Chen, "Iterative clipping-noise compression scheme for papr reduction in OFDM systems," *IEEE Access*, vol. 7, pp. 134348–134359, 2019.
- [28] P. Varahram and B. M. Ali, "Partial transmit sequence scheme with new phase sequence for PAPR reduction in OFDM systems," *IEEE Trans. Consum. Electron.*, vol. 57, no. 2, pp. 366–371, 2011.
- [29] M. Ali, R. K. Rao, and V. Parsa, "PAPR reduction in OFDM systems using clipping based on symbol statistics," *Can. Conf. Electr. Comput. Eng.*, vol. 1, no. 2, pp. 1–5, 2017.

- [30] A. Idris, N. L. Mohd Sapari, M. Syarhan Idris, S. S. Sarnin, W. Norsyafizan Wan Mohamad, and N. F. Naim, "Reduction of PAPR Using Block Coding Method and APSK Modulation Techniques for F-OFDM in 5G System," *IEEE Reg. 10 Annu. Int. Conf. Proceedings/TENCON*, vol. 2018-Octob, no. October, pp. 2456–2460, 2019.
- [31] S. Gokceli, T. Levanen, T. Riihonen, M. Renfors, and M. Valkama, "Frequency-selective papr reduction for OFDM," *IEEE Trans. Veh. Technol.*, vol. 68, no. 6, pp. 6167–6171, 2019.
- [32] H. Y. Liang, "Selective Mapping Technique Based on an Adaptive Phase-Generation Mechanism to Reduce Peak-to-Average Power Ratio in Orthogonal Frequency Division Multiplexing Systems," *IEEE Access*, vol. 7, pp. 96712–96718, 2019.
- [33] D. U. Kim and S. Kim, "Anti-Islanding Detection Method Using Phase-Shifted Feed-Forward Voltage in Grid-Connected Inverter," *IEEE Access*, vol. 7, pp. 147179–147190, 2019
- [34] R. Dorf, M. Simon, L. Milstein, Z. Wan, L. Milstein, and M. Simon, *Digital Communications: Fundamentals and Applications*. 2013.
- [35] K. Ramadan, M. I. Dessouky, and F. E. Abd El-Samie, "A Modified OFDM Configuration with Equalization and CFO Compensation for Performance Enhancement of OFDM Communication Systems," *AEU - Int. J. Electron. Commun.*, p. 153247, 2020
- [36] E. De Roux, M. Terosiet, F. Kölbl, M. Boissière, A. Histace, and O. Romain, "OFDM-based electrical impedance spectroscopy technique for pacemaker-induced fibrosis detection implemented in an ARM microprocessor," *Microprocess. Microsyst.*, vol. 70, pp. 38–46, 2019.
- [37] A. Kakkar, S. N. Garsha, and O. Jain, "2017 IEEE 7th International Advance Computing Conference Improvisation in BER and PAPR by using hybrid reduction techniques in MIMO-OFDM employing channel estimation techniques," *2017 IEEE 7th Int. Adv. Comput. Conf.*, pp. 170–173, 2017.

- [38] Y. C. Wang and Z. Q. Luo, "Optimized iterative clipping and filtering for PAPR reduction of OFDM signals," *IEEE Trans. Commun.*, vol. 59, no. 1, pp. 33–37, 2011.
- [39] G. Wunder, R. F. H. Fischer, H. Boche, S. Litsyn, and J.-S. No, "The PAPR problem in OFDM transmission: New directions for a long-lasting problem," *IEEE Signal Process. Mag.*, vol. 30, no. 6, pp. 130–144, 2013.
- [40] Y. Rahmatallah and S. Mohan, "Peak-to-average power ratio reduction in OFDM systems: A survey and taxonomy," *IEEE Commun. Surv. tutorials*, vol. 15, no. 4, pp. 1567–1592, 2013.
- [41] V. D. Nguyen and H. Kuehni, "Intercarrier and Intersymbol Interference Analysis of," pp. 140–144, 2003.
- [42] P. Soundararajan and V. Bhaskar, "Inter-Carrier Interference Power Analysis of OFDM Systems under Slowly Fading Channels," pp. 11–17, 2012.
- [43] S. Kumar, F. Kaltenberger, A. Ramirez, and B. Kloiber, "A Robust Decoding Method for OFDM Systems under Multiple Co-Channel Narrowband Interferers," *2018 Eur. Conf. Networks Commun. EuCNC 2018*, pp. 368–372, 2018.
- [44] J. P. Patra, "Co-channel Interference Suppression Techniques for STBC OFDM System over Doubly Selective Channel," *TENCON 2015 - 2015 IEEE Reg. 10 Conf.*, pp. 1–6, 2015.
- [45] ETSI, "Digital Video Broadcasting (DVB): Implementation guidelines for a second generation digital terrestrial television broadcasting system (DVB-T2). Sophia Antipolis." ETSI France, 2012.
- [46] A. Sharma and A. Kr. Singh, "Orthogonal Frequency Division Multiplexing and its applications," *Int. J. Comput. Trends Technol.*, vol. 38, no. 1, pp. 21–23, 2016.
- [47] H. Elgala, R. Mesleh, H. Haas, and B. Pricope, "OFDM visible light wireless communication based on white LEDs," *IEEE Veh. Technol. Conf.*, pp. 2185–2189, 2007.

- [48] S. Dimitrov and H. Haas, "Information rate of OFDM-based optical wireless communication systems with nonlinear distortion," *J. Light. Technol.*, vol. 31, no. 6, pp. 918–929, 2013.
- [49] X. Li, J. Vucic, V. Jungnickel, and J. Armstrong, "On the capacity of intensity-modulated direct-detection systems and the information rate of ACO-OFDM for indoor optical wireless applications," *IEEE Trans. Commun.*, vol. 60, no. 3, pp. 799–809, 2012.
- [50] A. Sharif, V. M. Potdar, and R. A. Ahmad, "Adaptive channel coding and Modulation scheme selection for achieving high throughput in wireless networks," *24th IEEE Int. Conf. Adv. Inf. Netw. Appl. Work. WAINA 2010*, pp. 200–207, 2010.
- [51] A. Gangwar and M. Bhardwaj, "An Overview: Peak to Average Power Ratio in OFDM system & its Effect," *Int. J. Commun. Comput. Technol.*, vol. 01, no. 2, pp. 22–25, 2012.
- [52] J. Moon, Y. Nam, E. Choi, B. Chen, J. Kim, and A. F. System, "2017_Selected Data Utilization," pp. 741–743, 2017.
- [53] S. Li, I. Romdhani, W. Buchanan, S. Li, I. Romdhani, and W. Buchanan, "Password pattern and vulnerability analysis for web and mobile applications," *ZTE Commun.*, vol. 14, no. S0, pp. 32–36, 2016.
- [54] P. RANI, S. BAGHLA, and H. MONGA, "an Improved Papr Reduction Technique for Universal Filter Multi-Carrier Modulation," *Acta Electrotech. Inform.*, vol. 18, no. 1, pp. 41–46, 2018.
- [55] T. Long Calvin, "Elementary introduction to number theory," Lexington, DC Heath Company, LCCN, vol. 77171950, p. 7, 1972.
- [56] C. G. Stewart, "A History of Fermat ' s Last Theorem and Modern Mathematics," 2018
- [57] S. J. Schlicker, "Numbers simultaneously polygonal and centered polygonal," *Math. Mag.*, vol. 84, no. 5, pp. 339–350, 2011.
- [58] Y. A. Jawhar et al., "A Review of Partial Transmit Sequence for PAPR Reduction in the OFDM Systems," *IEEE Access*, vol. 7, pp. 18021–18041, 2019.

- [59] N. K. Jadav, "A Survey on OFDM Interference Challenge to improve its BER," *Proc. 2nd Int. Conf. Electron. Commun. Aerosp. Technol. ICECA 2018*, no. Iceca, pp. 1052–1058, 2018
- [60] Z. S. H. AL-Hashmi, "An Overview: Peak to Average Power Ratio (PAPR) in OFDM system using some new PAPR techniques (with matlab code)," *Eng. Oct*, vol. 3, 2015.

