



T.C.

ALTINBAS UNIVERSITY

Institute of Graduate Studies

Electrical and Computer Engineering

**ANOVLE ALGORITHM TO EFFICIENT
SELECTIVE MAPPING PAPR REDUCTION
TECHNIGUE**

ADEL ALI ALSONOUSI SAEID

Master of Science

Supervisor

Prof. Dr. Oğuz BAYAT

Istanbul, 2021

**ANOVLE ALGORITHM TO EFFICIENT SELECTIVE MAPPING PAPR
REDUCTION TECHNIQUE**

by

ADEL ALI ALSONOUSI SAEID

Electrical and Computer Engineering

Submitted to the Institute of Graduate Studies

in partial fulfillment of the requirements for the degree of

Master of Science

ALTINBAŞ UNIVERSITY

2021

The thesis titled “ANOVLE ALGORITHM TO EFFICIENT SELECTIVE MAPPING PAPR REDUCTION TECHNIGUE” prepared and presented by ADEL ALI ALSONOUSI SAEID was accepted as a Master of Science Thesis in Electrical and Computer Engineering.

Prof. Dr. Oğuz BAYAT

Supervisor

Thesis Defense Jury Members:

Prof. Dr. Oğuz BAYAT

School of Engineering and
Natural Sciences,

Altinbas University

Asst. Prof. Dr. Oğuz ATA

School of Engineering and
Natural Sciences,

Altinbas University

Assoc. Prof. Dr. Adil Deniz DURU

Faculty of Sport Sciences,

Marmara University

I certify that this thesis satisfies all the requirements as a thesis for the degree of Master of Science.

Approval Date of Institute of Graduate Studies:

____/____/____

I hereby declare that all information in this document has been obtained and presented in accordance with academic rules and ethical conduct. I also declare that, as required by these rules and conduct, I have fully cited and referenced all material and results that are not original to this work.

ADEL ALI ALSONOUSI SAEID

ACKNOWLEDGEMENTS

All praises is to ALLAH Subhanahu wa ta'ala for bestowing me with health, opportunity, patience, and knowledge to complete this research. May the peace and blessings of ALLAH Subhanahu wa Ta'aala be upon Prophet Muhammad (Sallallahu alayhi wa sallam).

My profound gratitude goes to my supervisor Professor Asst. prof. DR. Oğuz Bayat, for his invaluable guidance, excellent supervision, continuous encouragement and constant support in making this research possible. His cooperation, tolerance, constructive criticism and useful suggestions have been of immense encouragement to me and enabled me to develop a deeper understanding of this research. I sincerely thank him for the time spent in proofreading and correcting my mistakes.

I am especially indebted to my parents, who were my first teachers in this world by setting a good example for me about how to live, study, work and for their love, sacrifices, and support. I also acknowledge with thanks and humility my wife and daughter who have remained my anchor in terms of love, support, encouragement and prayers. I will forever remain grateful to them.

Finally, I extend my gratitude to all those who were directly or indirectly involved by either encouraging, praying and offering constructive advice in this thesis.

DEDICATION

First and foremost, I would like to thank Allah Almighty for giving me the knowledge, ability and opportunity to undertake this research study and to persevere and complete it satisfactorily. Heartfelt thanks goes to my father and my mother. Every success is a direct consequence of their influence in my life and their love. At the end I have to mention my brother and sister for their support and love.



ABSTRACT

ANOVLE ALGORITHM TO EFFICIENT SELECTIVE MAPPING PAPR REDUCTION TECHNIQUE

ALSONOUSI SAEID, ADEL ALI,

M.Sc., Electrical and Computer Engineering, Altınbaş University,

Supervisor: Prof. Dr. Oğuz BAYAT

Date: Feb /2021

Pages: 59

According to the requirement of improvement communication field there would be great sum rate base on evaluate both of high performance of power efficiency and lower bit error rate. The demand for high-data rate and bit error rate, improve the efficiency of compromising between the trade-off can be performed with a carrier frequency. Frequency selective fading environment, it is a little more with a bit error rate performance for the truck speed is very difficult to achieve a high data rate. Multi-carrier systems with a variety of methods to reduce peak to average power ratio (PAPR) in carrying out the research in addition to reducing the PAPR and salaries. There are a few methods are recommended for effective power management. As described as such, clipping and filtration methods, the code is a Partial Transmit Sequence (PTS), Selected Mapping (SLM) and interweave literature. This project used the SLM technique Modulation schemes and a set of other studies and analysis of a number of subcarriers. As well as by other means, SLM scheme metrics are analyzed and can be compared. In addition, we are cut off or DCT (discrete code transform), PAPR results. The code, or compression scheme, the output of the Invers fast Fourier transfer (IFFT) SLM scheme has already been cut or the code signal is used. Arlberg scheme tends to miss the information, and we, along with the code for the

DCT multicarrier systems may contain useful information for the proposed use of the SLM, and will lead to higher and higher. This is measured using the same MATLAB PAPR reduction schemes.

Keywords: Efficient Selective, PTS, DCT, SLM, Peak To Average Power Ratio, MATLAB PAPR



TABLE OF CONTENTS

	<u>Pages</u>
ACKNOWLEDGEMENTS	v
DEDICATION	vi
ABSTRACT	vii
LIST OF FIGURES	xii
LIST OF ABBREVIATIONS	xiii
1. INTRODUCTION	1
1.1 INTRODUCTION.....	1
1.2 PROBLEM STATEMENT	3
1.3 OBJECTIVES.....	4
1.4 PROJECT SCOPE.....	4
1.5 THESIS OUTLINE	5
2. LITERATURE REVIEW	6
2.1 OVERVIEW	6
2.2 COMMUNICATION SYSTEM IN OFDM.....	6
2.3 MULTIPATH CHANNELS.....	9
2.4 MUTI-CARRIER TRANSMISSION SCHEMES	9
2.5 OFDM TRANSMISSION SCHEME.....	10
2.5.1 Advantages of OFDM	11
2.5.2 Disadvantages of OFDM	12
2.6 INTER SYMBOL INTERFERENCE	12
2.7 INTER CARRIER INTERFERENCE	13
2.8 CYCLIC PREFIX.....	13
2.9 PEAK TO AVERAGE POWER RATIO	14
2.9.1 Clipping	15
2.9.2 Interleaving.....	16

2.9.3	Tone Reservation (TR)	16
2.9.4	Tone Injection (TI)	16
2.10	CODING TECHNIQUE	16
2.11	PREVIOUS STUDIES	17
2.12	SUMMARY	17
3.	METHODOLOGY	19
3.1	INTRODUCTION	19
3.1.1	Effect of High PAPR	19
3.1.2	PAPR Reduction Techniques	20
3.1.3	Amplitude Clipping and Filtering	20
3.2	COVENANTAL SLM FOR OFDM	22
3.3	MODIFIED SELECTING MAPPING	24
3.4	NEW SELECTING MAPPING FOR OFDM	25
3.4.1	Partial Transmit Sequence (PTS)	25
3.5	SELECTED MAPPING (SLM) COMBINED WITH CLIPPING	26
3.6	SELECTED MAPPING (SLM) COMBINED WITH CODING	27
3.7	POWER SAVINGS THROUGH SELECTED MAPPING	27
3.8	SUMMARY	29
4.	SIMULATIONS RESULTS	30
4.1	OVERVIEW	30
4.2	IFFT SIGNAL FOR CLIPPING	30
4.3	PERFORMANCE ANALYSIS AT INCREASES NUMBER OF SUBCARRIER	33
4.4	CHAPTER SUMMARY	37
5.	CONCLUSIONS	39
5.1	CONCLUSIONS	39
5.2	FUTURE WORK	40
	REFERENCES	41

APPENDIX A **46**
APPENDIX B **47**
APPENDIX C **48**



LIST OF FIGURES

	<u>Pages</u>
Figure 2.1: Block diagram for digital communication system	8
Figure 2.2: Multipath propagation in communication system	10
Figure 2.3: Inter symbol interference for OFDM	13
Figure 2.4: Cyclic prefix in communication system.....	14
Figure 3.1: SLM for OFDM block diagram.....	21
Figure 3.2: Conventional SLM for block diagram.....	24
Figure 3.3: Block diagram Conventional PTS.....	26
Figure 4.1: Related of Amplitude IFFT with time after clipping	30
Figure 4.2: Related of PAPR for CPM	31
Figure 4.3: Related of PAPR for SLM.....	32
Figure 4.4: Related of PAPR with and without SLM	32
Figure 4.5: Related of PAPR for CCDF with and without SLM	33
Figure 4.6: Related of PAPR for CCDF when $N=256$	34
Figure 4.7: Related of PAPR for CCDF when $N=64$	35
Figure 4.8: Related of PAPR for CCDF when $N=128$	36
Figure 4.9: Related of PAPR for CCDF when $N=512$	37

LIST OF ABBREVIATIONS

OFDM	: Ortogonal Frequency Division multiplexing
CCDF	: Cumulative distribution function
SLM	: Selective mapping
PAPR	: Peak to average power ratio
ADC	: Analog to digital converter
DAC	: Digital to analog converter
ISI	: Inter symbol interference
CPM	: Continuous phase frequency
BPSK	: Binary phase shift keying
IFFT	: Invers Fast Fourier transform
ICI	: Inter carrier interference
RF	: Radio frequency
DVB	: Digital Video Broadcasting
DAB	: Digital Broadcasting
TI	: Tone Injection
PTS	: Partial Transmit Sequence
ACE	: Active Constellation Extension
TR	: Tone Reservation
PM	: Phase Modulation

PA : power amplifier

QPM : Quadrature phase modulation

PSK : Phase Shift by keying

DFT : Discrete-sided transformation

QAM : quadratic amplitude modulations

BER : Bit Error Rate



1. INTRODUCTION

1.1 INTRODUCTION

In telecommunication, The requirement and demand for achieve the high data rate facilities have been growing very quickly and there is no slowdown in vision. We know that this includes both the wired and wireless data transfer mediums. In many cases, this is a very harsh environment requires a very reliable data transfer. Most of the transmission systems, such as a corrupted, attenuation, noise, multipath, interference contrast, time limit, nonlinearities, and electricity is subject to limitations such as cost and limited. In dealing with this poor, has grown in popularity until a physical layer method is a method of multi-carrier Modulation. multi-carrier frequency, the most frequently used method is the Orthogonal Frequency division multiplexing (OFDM); Recently, wireless communication has become very popular. Unfortunately, the lack of transmission, OFDM main average power ratio (PAPR) for the top as a number of indicators of change in a large envelope. which will operate on a linear power amplifier, a perfect area, since a transmitter is used in existing low power this is to reduce PAPR lot.

All methods have advantages and disadvantages of any [1]. Allberg and distortion Filtering is one of the main methods of portions of the transmitted signal. Coding

scheme also reduces the data is undesirable. The Tone Reservation, (TR) method is also likely to increase the power and the data rate can be harmful. Other methods, such as Tone Injection (TI) and Active Constellation Extension (ACE) with increasing power of one criterion can adversely interfere with the electrical environment. Part of Mars (PTS) and transferred to the selected method (SLM) technique to use a Partial Transmit Sequence (PTS) if you are traveling more than SLM technology complexity.

This selected Mapping technique signal is provided for the implementation introduces no distortion, and is one of the simplest methods. This is the first [2] is known as the classic method of SLM Yes. This approach provided additional information Side (SI) with OFDM signal with one of the disadvantages of sending the index. This can avoid using a technique known as [3]. This thesis is the concentration of the selected mapping method. This method of analysis is being done. Side Information (SI) Index of them in order to avoid periodic OFDM signal, along with

additional information on how is one to avoid. This technique is more important is to reduce the calculation of the analysis of the complex. As well as a critical analysis of this technique are used in different stages of the route should be about the interaction between independence.

At any given time, as well as the classic method of reducing the complex calculation of the SLM is proposed that priority is given to reducing PAPR. In addition, the proposed method also avoids sending an additional SI index. a step forward towards multi-carrier Modulation scheme, taking into account the margin of error without degrading the performance of the channel fading and multipath can get a loan with a high data rate. Using multi-carrier Modulation in order to achieve a good result, we subcarriers Orthogonal Frequency division multiplexing (OFDM) method, which is called to one another, ie. In order to be orthogonal OFDM technology, however, many defects Average Power Ratio (PAPR) is the highest summit. We linear power line due to the operating point of the amplifier in the high PAPR-robbes, leads a group of distortion and was used to fill the area with light. This base station is high, high cost, and power consumption by increasing the dynamic range of the fees can be avoided. This report presents an efficient way to reduce PAPR Selected Mapping ie. Also, this method of analysis for the bit error rate performance and computational complexity are discussed

here. Along with the analysis using this method, and the other between OFDM signals, as well as analysis of the importance of the independence of the proposed well. reducing the complex calculation and reduce the PAPR, which satisfies the criteria of this proposed scheme. In addition, this new scheme and the OFDM signal is transmitted along with additional forehead advantage. This scheme may be used, as well as a number of transmitting antenna.

Orthogonal Frequency Division multiplexing (OFDM) used in many of the latest wireless standards multicarrier Modulation is a type of technology. An OFDM standard for digital broadcasting (DAB), Digital Video Broadcasting (DVB) standard, such as [1] has been accepted for many of the standards. According to the high peaks of the transmitter reduces the efficiency of the RF power amplifier power. This base station is high, high cost, and power consumption by increasing the dynamic range of the fees can be avoided. The highest rate in the demand for services is growing rapidly in the wireless environment. The wireless communications, for example, the speed, simplicity, mobility and flexibility, there are many advantages, but, at the same time, the banks suffer from inter-symbol interference (ISI) and the multipath propagation

(fading frequency selective). In dealing with this poor, has grown in popularity until a physical layer method is a method of multi-carrier Modulation. Multi-carrier frequency, the most frequently used method is the OFDM. Recently, wireless communication has become very popular. On the other hand, an OFDM Power quantitative indicator as the ratio of peak to average daily suffers from a large envelope (PAPR). Power amplifier of the transmitter is used, therefore, for a lot of these PAPR reduction algorithms have been developed. All methods have advantages and disadvantages of some [1-4]. The tops of the high-PAPR signal causes distortion of the RF signal derived moved to a non-linear region. PAPR similar to digital and digital-to-analog converters increases the complexity and reduces the efficiency of the RF wages. Researchers have recently found ways to reduce PAPR in many cases, the code is expected from there, and the selected Renaissance (SLM) [5].

An OFDM is a large number of closely-spaced orthogonal carriers. is spread over the sources of information should be provided, and a little bit of each helicopter carrier

is modulated at the rate of [2]. The advantage of the majority of the OFDM carriers, the overlapping of the intervention was not the cause of the high frequency spectrum efficiency between a minimum of interference in the sources of Orthogonality. This separation between the carriers will be realized.

1.2 PROBLEM STATEMENT

Mitigated the interference in the OFDM high spectral efficiency and immunity to multicarrier Modulation is a type of technology. OFDM system is one of the main disadvantages of electric power ratio (PAPR) with a practical power amplifiers used in the distribution of electricity is the highest mountain in inefficiency and leads to distortion of the signal. Selective Mapping (SLM) electricity demand caused by the increase in the rate of loss is the method can effectively reduce the PAPR without damage. Coach shows the results of the proposed method of SLM has good PAPR reduction performance.

The OFDM system is one drawback, wages undermines the effectiveness of the peak of a high-average power ratio (PAPR). Therefore, PAPR reduction is very important for OFDM systems [6-8]. An OFDM signal is sinusoidal private carriers. This merger of sinusoids IFFT input stage and consistent, OFDM IFFT output signal with a high PAPR may be a result of large amplitude.

OFDM signal is the largest high-amplitude associated with a number of subcarriers, and it is the way of the number of single-carrier system. PAPR in a large high peaks of the sender and / or recipient of a power amplifier used in an area full of overflow, OFDM signals to manipulate a group of OFDM subcarriers, as well as the Inter-Modulation interference and suffer from nonlinear distortion [7-12].

In OFDM-year, due to the chains of radio frequency (RF) power amplifier efficiency cannot be run for the high PAPR. This amplifier linear region, the military group,

distortion, noise, and should be used for the violation. In addition, the high PAPR high-resolution digital-to-analog converter (DAC) and is similar to analog todigital converter (ADC). Low PAPR power amplifier efficiency, and reduces the complexity as well as the DAC and Analog to digital converter [10].

1.3 OBJECTIVES

The objectives of this thesis can be represented as :

- To achieve better performance using multi carrier modulation based on used Selected Mapping (SLM) technique for reducing the PAPR of OFDM.
- To propose scheme based on partitioning the frequency domain symbol sequence into several sub-blocks when the length is shorter than that the conventional SLM scheme to achieve the lowest computational complexity.
- To perform a data block of an OFDM based on used the lowest PAPR signal using an independent phase sequences for CPM.

1.4 PROJECT SCOPE

The thesis scope will be concentrating on three main factors which are embodied as follows:

- To achieve better performance based on used selected mapping technique that is used to resolve ISI and ICI.

- To propose effective PAPR reduction scheme for OFDM system based on partitioning the frequency domain for probability of error.
- To achieve the power saving through selected mapping with lowest PAPR.

1.5 THESIS OUTLINE

Chapter 1 Provides information on project design. this input PAPR with SLM, and impact of transmit power, problem statement, in addition to, study the objective of this project and scopes.

Chapter 2 Describe the fundamental of transmission signal during communication system used the OFDM through described many of techniques that used to enhance transmission signal such as inter symbol interference, inter carrier interference, cyclic prefix, Peak to average power ratio, clipping, interleaving.

Chapter 3 Propose the SLM performance for a high computational complexity which used to reduce the peak to average power ratio based on mitigated inter symbol interference and inter carrier interference.

Chapter 4 Simulated the OFDM system with different number of subcarriers and with sub blocks in addition used the new techniques for continuous phase modulation (CPM) and BPSK for selective mapping using MATLAB simulation.

Chapter 5 Summaries the conclusion and the suggestions of interesting topics of this project for future works.

2. LITERATURE REVIEW

2.1 OVERVIEW

In this chapter, This chapter describes and explains the general idea about the important of used the OFDM and study how can to minimize the peak to average power ratio during the transmitted signal in communication system. This chapter it will be explain the principle of communication system in OFDM, multipath channel, multi-Carrie transmission scheme, OFDM transmission scheme, advantages and disadvantage of OFDM. In addition to, explain Inter Symbol Interference, inter carrier interference, cyclic prefix, Peak to average power ratio, clipping, interleaving, Tone Reservation, Tone Injection and coding techniques.

2.2 COMMUNICATION SYSTEM IN OFDM

The conventional In a typical carrier systems for remote channel was forced to include the effect of multipath nature can accomplish the same addiction rates. At the end of the high-data rate video and audio applications [1], is favorable. But as the war of information, build a base, correspondence, and reduced time to stop him. After that, the regulation of the transporter to use the experience of the outside base along these lines, which requires a complex equilibrium system, the Inter-symbol interference (ISI) in the dispersive channel disk led to significant positive impact. Orthogonal Frequency Division multiplexing (OFDM) multicarrier is an extraordinary type balance, beautiful blurring plan of sub-channels, many orthogonal group distinguishes the degree of repetition, especially opacity channel. In OFDM base, a high bit-rate data traffic delivered over a variety of series rate, not a sign of subcarriers and a long duration of ISI [2]. OFDM interests of the significant points for the sub-carriers in high volumes, is an almost vertical frequency range of spectral information. Recognition of the use of the FFT operation and simple computerized. The cyclic prefix used to decreases the less complex, consisting of quite a lot of pages with reduced Inter Symbol interference .

Various noises plans can be used with regard to the individual sub-carriers, the conditions of each sub-carrier. What OFDM endless studies, the peak of a high-average power ratio (PAPR) directly with the need to strengthen the OFDM signals. You can do one more thing, corruption and the power of the group's modulation.

The OFDM symbol envelope variance of OFDM is one of the serious drawbacks. These range from the outside of the base is restricted on the grounds that the highest authority in difficulty. The tops of these lines, the envelope quickly sign a sign of power, average power and low power efficiency, or the power amplifier (PA) that require sophistication to suit a lot of ground to oblige. with significant changes to the envelope for the OFDM signal for a specific purpose, with the greatest range Pas it is too rich, it is mandatory. If the PA spectrum of radiation of the group is not directly mode and injured in the military operation is limited. It is also important for the D/A and A/D converters with

A simple mark and other discrete time change sign OFDM multi-item scale. Peak-a-average power ratio (PAPR) OFDM mark envelope is used to describe the change is for the most part, and the average power is defined as the ratio of the provisional government. In spite of this, OFDM base requires a strong interaction within the framework of the transporter, frequency synchronization, OFDM, subcarriers on the grounds there is a narrow band. May he transmitted and are sensitive to the balance between low frequency signal. frequency, Doppler effects, or a mix between the transmitter and collector regional vibrational frequency can arise. The frequency of the carrier (PM) on a subcarrier between subcarriers orthogonality, and this designation is angry can freely move the remaining subcarriers. To accommodate this enormous blunder free demodulation and OFDM symbols, is a very big challenge, known as inter-carrier interference (ICI).

Figure 2.1 illustrates the overall digital communication system blocks. A/D converter digital binary sequences, ie the form is used to convert analog source. a source coding can be adopted with no loss of compression, for example, the digital information is delivered to a certain extent in order to succeed. Some coding techniques such as the main source of Hoffman coding and Shannon-Fano code is available.

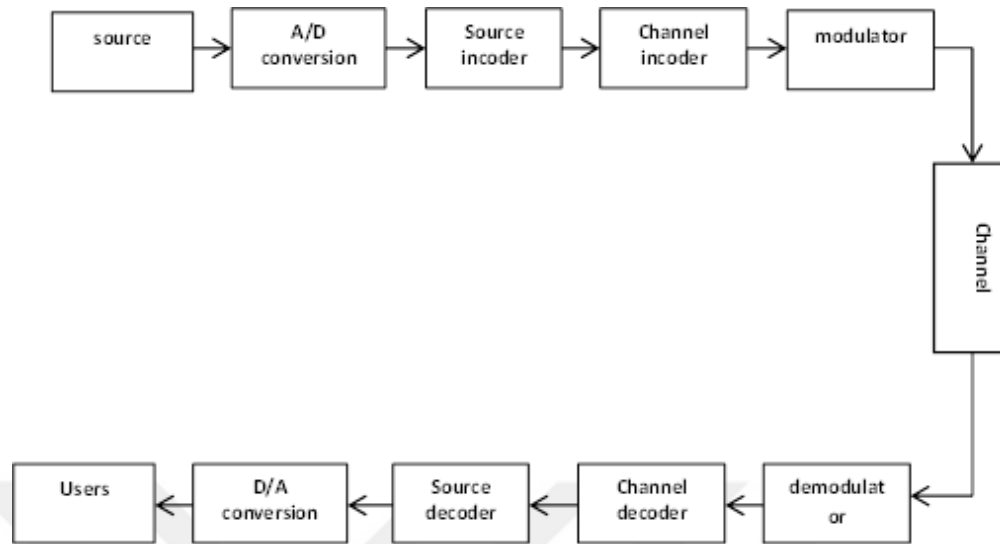

Figure 2.1: Block diagram for digital communication system

The purpose of the encoding source, the source is not superfluous. Also referred to as the source of his information from the encoder and double-digit number of the channel encoder. The signal received by the encoder for a reliable communication channel information does not lead to excessive forehead. the channel encoder, called a code-bit sequence information into maps on its forehead. The ratio of n-channel encoder and the measures introduced by a mutual reduction of the ratio is called the code rate. The volume of the channel encoder is a digital modulator.

The modulator signal digital signals into binary data sequence maps. Modulation may be binary or m-east. With the frequency of the binary signals, two-eastern Modulation is used to represent the binary digits 0 and 1, where $N = 2^u$ a clear signal in bits used to represent a binary word. Modulated waveform channel is transferred to the transmitter through the receiver. In addition to a noisy channel, the transmitted signal is corrupted. The source of the noise and the random nature and often unexpected noise, thermal noise, air, noise, man-made and others. As of the end of the digital demodulator in the form of a discount to filter the type of detector or correlated type signals from the detector signal is applied to the binary sequence. A list of information to the demodulator of the Code will be transferred to the channel decoder it recovers.

The average probabilities of a bit-error depend on the decoder according to the results of a bit-error probability of the average combined demodulator Decoder is a measure of performance. However, the probability of error is characteristic of the channel, code, frequency, demodulation

and decoding methods. Eventually, the source will produce Decoder transmitted source. The average output signal source encoders and decoders have introduced errors and signal distortion. The difference is the solution to the distortion introduced by the digital communication system. This conventional signal through an analog to digital converter and will be adopted by the end user.

2.3 MULTIPATH CHANNELS

The transmitted signal faces at different times to reach the source of the received signals as a result of various obstacles and displaying pages. This will affect other signals from the echoes. Ceramics constants, conductivity, and influenced by the width of the system is the main reason. Multipath channel closed area augmentation system echoes the procedure and minimize the effect of this invention. Measures to avoid the ISI (Inter Symbol interference) should be adopted in order to reduce the Echo. Multi-path Figure 2.1 shows that the reason for the increase.

2.4 MUTI-CARRIER TRANSMISSION SCHEMES

In a single carrier system, cut-off, known as the fading frequency selective distortion, ie, is the reason for the transition into the entire data stream. The beginning of a single-carrier wideband channel several times to select the speed of elimination, can be used to carry the high rate data. In a multi-carrier [4], the flow of information in a number of subcarriers. Figure 2.2, a multicarrier system, the basic structure and concept of the show.

This multicarrier frequency-selective wideband channel using multiple frequency is representative of the narrow band channels. N is divided into sub-channels in the narrow band and wideband frequency of the subcarrier f_k $k = 0, 1, \dots, N - 1$. Sub-channel interference suppression Orthogonality distortionless ICI (Inter Carrier) the transfer must be supported. This scheme, therefore, any signs transmitted in orthogonal sub-channel Racing. oscillators, each sub-channel is used for the development of the subcarriers, it can be hard for the implementation of these schemes. This is an important scheme for Orthogonal Frequency division multiplexing to consider, in order avoiding complexity.

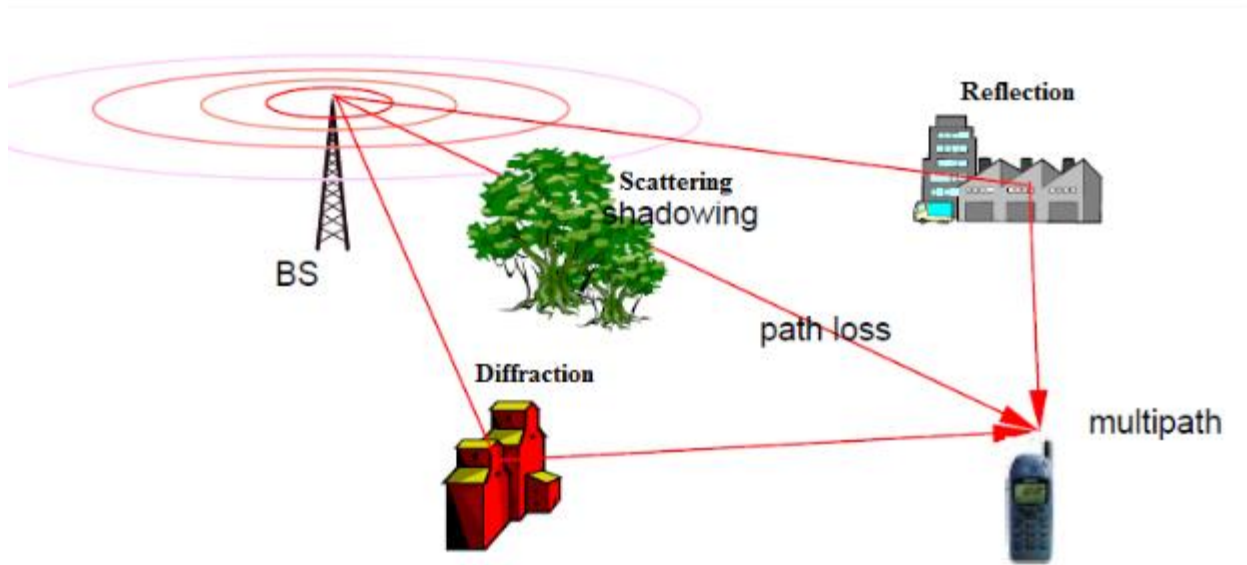

Figure 2.2: Multipath propagation in communication system

2.5 OFDM TRANSMISSION SCHEME

Orthogonal frequency division multiplexing scheme [5], [6], for each sub-channel is limited, oscillators and filters network is a type of channel system. OFDM technology for the first time in the 1960s, and in 1970, was conceptualized. The main idea of OFDM low price Barnett multipath are less sensitive than the best way to send a high-rate waveform is to send a number of streams of a number of lower cost. This channel effects of a sub-group is stable enough (flat), so small sub-group of the frequency spectrum allocated. In the classic IQ (in-phase and Quadrature phase), speed (BPSK, QPSK, M-coma, etc.) will be sent in a sub-group. If designed correctly, all the fast changing effects of the channel appeared to signal that they are now, and so on as the fading disappear.

One of the closely-spaced orthogonal subcarriers used in a large number of tons. information from multiple parallel data streams or channels, one for each subcarrier is divided. The speed of each subcarrier to normal Modulation scheme Quadrature Amplitude (coma), or Phase Shift by keying (PSK), with the lowest rate is modulated. The total data rate as with a conventional carrier Modulation scheme which is similar to retention. Orthogonal Frequency Division multiplexing (OFDM) to achieve the highest data rates and wireless fading multipath control method. Orthogonal Frequency Division multiplexing of a dispersive channel, especially suited

for multicarrier is a special type of Modulation. At this point, every one of the carriers, and other helicopters, they are completely independent of each other. This is clearly to each other, which is modulated by a carrier in the range of nulls occur.

Each truck means there are cycles in the whole carrier orthogonality. The range of the carrier in connection with the conversion, the number of integers, each of them as much as possible close to the international road carriers, without any interference between the results of this system, operators at each center frequency is zero. Frequency division multiplexing (among young people) and students can restore the carrier spacing issues. Therefore, the effectiveness of this scheme, multicarrier capabilities [7], in order to retry the spectra of subcarriers [7].

2.5.1 Advantages of OFDM

The Orthogonal Frequency Division multiplexing (OFDM) scheme has the following advantages

1. OFDM frequency and demodulation functions for the implementation of the FFT calculation using the method is effective.
2. Sub-channels with channel fading into a flat narrow band division, OFDM carrier system according to the fading frequency selectivity to be more stable.
3. By using the channel with coding and interweave, and 3 to select the speed of the channel because of the missing signs, can be recovered.
4. OFDM of a post-effective channels Modulation scheme and, in the fading frequency selective advantage to reduce the ISI.
5. Channel equalization and leveling systems and the flexible use of a truck and not be simpler.
6. Along with a variety of speed, and a channel for the implementation of any kind is needed.
7. Co-channel interference and provides protection against parasitic noise, the emotion.
8. OFDM complex time-domain correction may be difficult to adapt to the channel conditions.
9. Consisting of 9 prefix through the use of the Inter Symbol interference (ISI).
10. OFDM system according to the model of a truck while less dependent on Offsets.

11. The OFDM multipath fading and provides greater noise immunity.
12. Eat OFDM, by allowing more efficient use of spectrum.
13. There is no need to use of OFDM equalizers.

2.5.2 Disadvantages of OFDM

The OFDM scheme attractive technology, but there are disadvantages:

1. OFDM, Discrete-sided transformation (DFT), a carrier system according to the appearance depends on the carrier density and penetration.
2. OFDM is difficult to occurrence management problems.
3. It is complex to Doppler Shift.
4. OFDM signal with a very large dynamic range, such as amplitude noise; therefore, it is the high peak-to-average power ratio (PAPR) and the required RF power amplifiers.
5. The great PAPR growths the convolution of the Analog-to-Digital (A/D) and Digital-to-Analog converter (D/A).
6. The great PAPR also drops the productivity of reduction power amplifiers.

2.6 INTER SYMBOL INTERFERENCE

Increase Inter symbol interference (ISI), the following signs and a sign of a magma, which is a form of distortion of the signal. This marks the previous unconfirmed, some have a similar effect as the noise of the connection as well as is to be expected. Typically, multipath, propagation, or the next, along with signs of profit due to the linear frequency response of the channel. The ISI in the system make a decision on the output device error. Therefore, the goal of the design of the transmitter and receiver filters, and the effects of ISI may be a small error rate and the destination is to reduce the digital data delivery.

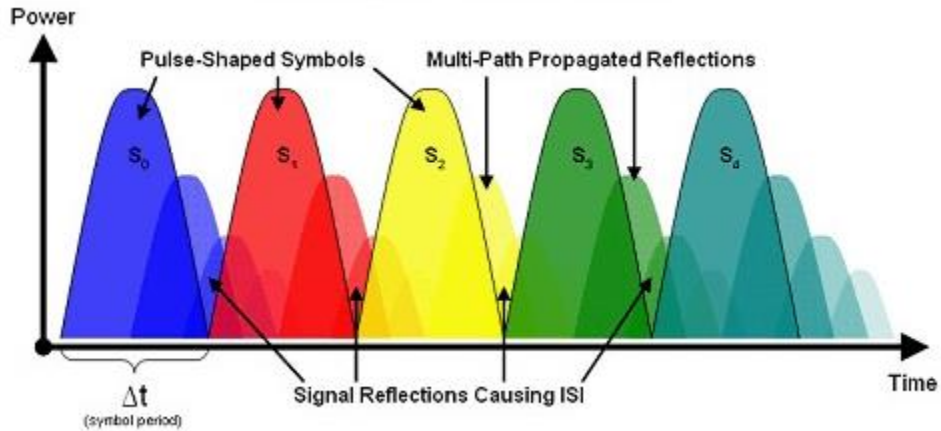

Figure 2.3: Inter symbol interference for OFDM

Pulse is not only the condition of the filters and frequency domain can be used to eliminate interference to adjacent channels, but at the same time on the same channel, following the signs can be used to overcome obstacles. Inter-symbol interference (ISI) signals to be transmitted over long distances and various environmental circumstances may also be caused in many ways. In particular, the physical environment of this feature is to distribute them within the given time, some signs will appear. As a result, they can interfere with the previously issued notes.

2.7 INTER CARRIER INTERFERENCE

The presence of Doppler shifts and frequency and phase offsets in an OFDM system causes loss in orthogonality of the sub-carriers. As a result, interference is observed between sub-carriers. This phenomenon is known as inter - carrier interference (ICI).

2.8 CYCLIC PREFIX

The cyclic prefix or guardians of the period up to the front range of the transmitter and the OFDM symbol in the last part of the extension from time to time and taken to the demodulation. According to Figure 2.4, the Cyclic Prefix (CP), with a serial number after the change takes place, and Discrete-sided earlier, was not with her. Taking into account the period cyclic prefix for OFDM symbol shown in Figure 2.4.

The wireless communication systems consisting of a multi-channel sensitive for cyclic Prefix and is added in order to minimize Inter Symbol interference. Prefix symbol, which is attached to

the end of the characters is a return to the first division. In addition, they are the next to be hindered by little more than the original signal and sends is important.

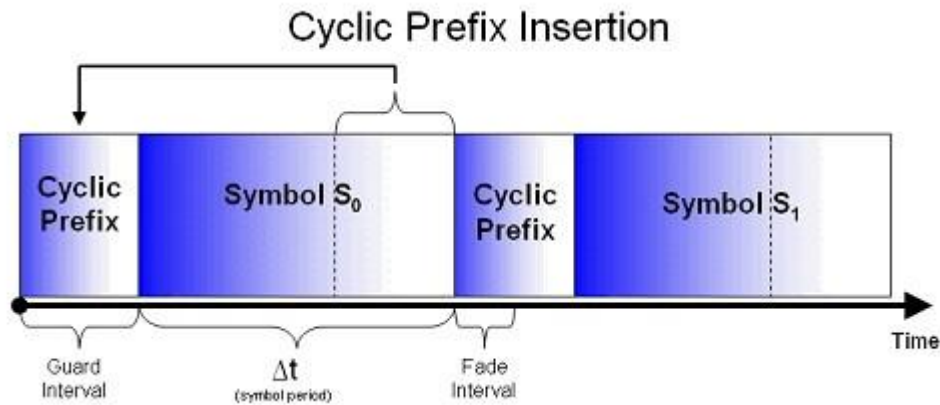

Figure 2.4: Cyclic prefix in communication system

2.9 PEAK TO AVERAGE POWER RATIO

The OFDM and PAPR high unpredictability of performance, productivity, and low, ghostly echoes and Contortion less vulnerable to many non-linear multicarrier Modulation procedures, is one. For this part of the OFDM used as a part of the other part of the outside and is deplorable, the real question is part of the base of this depends on the normal force, but may be saying. PAPR, simple comprehensive quality and computerized switch opens and reduces the efficiency of radio frequency (RF) power increased. Application management and reduction of the size of the carrier, such as those needed to reduce the transmitted power can be put to death.

This is nothing to be directly related to increased development and ghostly need to work to avoid transmitting electrical demand. Battery life is a bad influence. So, from the outside, relying on a high PAPR of multicarrier all possible advantages that maybe out-weighed. PAPR for the management of the various strategies. Some of them, having fun - cut, cut, and code is partially an inherited partial transmit succession (PTS) sample selecting mapping (SLM) and interweave. These systems PAPR minus sign in structural damage to the delivery of performance information, bit error rate (BER) expansion rate calculation Accident, multi-quality growth. A free part of the OFDM sub-carriers in the incredible number of regulated within the framework of the evaluation may be in conflict with a normal, high. The proportion of normal power quality

crest this is called peak-to-average power ratio. At the same stage N are rational expansion of N times normal is a sign of its crest. High PAPR disservices are as follows

1. Expanded in the simple multi-faceted nature enhanced computerized and simple switch.
2. Deterioration is competence of radio frequency speakers.

The (IFFT) and fast-sided negative change within the OFDM yield a truck comes to serious instability and conflict within the mountain tops. This, for example, the base of gadgets, speakers, digital converter (A/D), an analog and a digital to analog converter (D/A) converters, there is a direct element ranges. Theoretically, OFDM system, large peaks in the peak-to-average power ratio, or PAPR is true. This is defined as:

$$\frac{\text{peak power}}{\text{averag power}} = 10 \log_{10} \left[\frac{\max(x^u(t))^2}{E|x^u(t)|^2} \right] \quad (2.1)$$

Where E represent the signifies the expectancy or the poor; X_n represents the transmitted data signal in OFDM which are gets based on estimated the IFFT.

The reduction of PAPR systems according to the needs of change and are governed by different variables. PAPR year growth decreased, while the maximum signal strength, data rate Accident prevention processing, the receiving end of the bit error rate and growth in the framework of a PAPR is to be considered in the order of minus arms of different components. We are working on the PAPR reduction techniques, and our next step is the day came to a close, with the following:

2.9.1 Clipping

Clipping power back-off is insufficient, clipping always be in the transmitter. Trim motivate a group of clipping noise and light create due to the different of the cutting cost and unpredictability associated with the drop of the regrowth of the crest. According to the buyer clipping noise ratio is offered on a number of methods. One of them makes use of any sign of oversampled samples pattern.

2.9.2 Interleaving

The same data block is interleaved by K different interleaves. K IDFTs of the original data block and modified data blocks are calculated. PAPR of K blocks is calculated. The block with lowest PAPR is transmitted.

2.9.3 Tone Reservation (TR)

In order to reduce the high reservation tone, with the sub-carriers reserved. Reducing the meaning of the signals from highly suitable for the introduction of sub-carriers is calculated by linear programming algorithm. According to this method, the transmitter is optimized to reduce PAPR is to send information about the subcarriers small groups. This is an objective that would reduce PAPR In this original time domain signal can be found in the time domain signal. This is likely to increase more than the loss of power. is more.

2.9.4 Tone Injection (TI)

Tone injection initial constellation of cards (such as the idea Quadratic phase shift key (QPSK) increased the star (for example 16 quadratic amplitude modulations (QAM).) is reduced to a few constellation points. PAPR reduction spread through the constellation point selection the degree will be realized. The main idea of this technique is used is equal to the size of the data block in each note a few degrees of freedom is one of the points on the map, so that excessive purchases are to be without degrees in order to reduce the PAPR this increases the power transmitted.

2.10 CODING TECHNIQUE

Coding also can be used to reduce the PAPR. We are using this code based on used the convolutional encoding method. Some using the convolution encoder, a variety of levels as low PAPR and OFDM will choose to publish the pictures in conventional information resources. This convolution encoder, and slipped into a coma, coma, BPSK and 64-128, using various noises, such as noises, etc; is converted to the values of the IFFT and PAPR. Of course, the coveted PAPR level Littler, is to achieve a code of Littler. For 8-subcarrier OFDM (3dB) PAPR in as little as $\frac{3}{4}$ code will be part of the code. This is where the 3-bit data is 4-bit card is a temporary card.

In that case, the time range, with a much smaller PAPR is a reasonable measure of code words. Decreasing the code used to reduce the size of the PAPR of ideas quickly. To get back to the forehead and the same is done by using convolution decoder side. The coding method [10] to reduce or minimize the PAPR is used to select the code word. It has no distortion in addition no group has been a source of radiation, but the efficiency of the code to reduce the rate of transmission damage. As well as the best codes, and especially for the large number of subcarriers, Encoding and Decoding is difficult to store a large lookup sub carriers.

2.11 PREVIOUS STUDIES

The OFDM system undermines the effectiveness of the fees to feel the peak of a high-average power ratio (PAPR). Therefore, PAPR OFDM systems to reduce peak to average power ratio (PAPR) is very important to obtain the highest performance. The code writers in the author [29] on the basis of information OFDM packet inspection data block is used to reduce the PAPR proposed to embed phase sequence. The another authors [30] proposed the OFDM system undermines the effectiveness of the fees to feel the peak of a high-average power ratio (PAPR). Therefore, PAPR OFDM systems to reduce peak to average power ratio (PAPR) is very important to obtain the highest performance.

While the authors [31] proposed the factors affecting SLM performance and high computing complexity. To address the impact of this, in this [31], the opposite of the available time domain signals clearly sided blocks real, real fast, even sided with the use of the invention, the effects of a clear and coherent divided by changing the properties of the revolution. Filled with high PAPR area and thus signal with the point cut off the tops of the C-frame and creates a distortion of the group and the group takes place. Thus, in the linear C-point of salaries in order to preserve the dynamic range and reduces its efficiency and increases the cost should be increased. Thus, the trade-off there is a similarity between the nonlinearity and efficiency [32].

2.12 SUMMARY

In chapter 2, we discussed the important an peak to average power ratio is The OFDM and PAPR high unpredictability of performance, productivity, and low, ghostly echoes and Contortion less vulnerable to many non-linear multicarrier Modulation. In addition, this chapter study the

important of used selecting mapping and a variety of levels as low PAPR and OFDM will choose to publish the pictures in conventional information resources.



3. METHODOLOGY

3.1 INTRODUCTION

Chapter three it will describe the experiments in the Orthogonal Collection of orthogonal frequency division (OFDM) system is proposed as a standard for the next generation of mobile radio communications system. OFDM signals fading frequency selective mapping channels in a carrier Modulation better than the effective spectral power and the operation of the OFDM system. OFDM system, the major drawback of OFDM signal can have a maximum average power ratio (PAPR). high PAPR leads to linear distortion of the signal with the highest salaries (mbar), and the signal distortion induces bit error rate (poses). The algorithm of the selected card (SLM), the peak of a high-average power ratio (PAPR) orthogonal frequency division multiplexing (OFDM) has been used to reduce the signal. One of the reasons for SLM impact is difficult to calculate.

To eliminate the impact of this section, the opposite of the available time domain signals, a fast-sided transform (IFFT) blocks, real, real, even sided with the use of the invention is divided by changing the effects of a clear and coherent properties. Another candidate, in order to create different-domain signals exchanged for the appropriate consequences as SLM (M) antenna array IFFT linked to the use of M candidates SLM.

3.1.1 Effect of High PAPR

The linear power amplifiers should be reported to the transmitter. For filled with high PAPR point cut in the region so the signal peaks Q-point moved from within the military and creates a distortion of the group takes place. Thus, in the linear Q-point of salaries in order to preserve the dynamic range and reduces its efficiency and increases the cost should be increased. Thus, the trade-off is non-linear, and there are between the efficiency [1]. As well as the dynamics of the cost increases with the power amplifier. As a communications engineer, our objective is to reduce the PAPR.

3.1.2 PAPR Reduction Techniques

Orthogonal frequency division multiplexing is one of the strongest contender OFDM times, and the ability to reject interference, high spectral efficiency of 4G systems, and other wireless technology [1] is one of the strongest candidates. According to the SLM to reduce the calculation of complex, time-domain OFDM signal to provide accurate, real, real, imaginary and replaced, such as SLM, even stunning consequences, and under the strange, mythical and even further, for example, the consequences of any change in method of use Time will be developed with a regular, continuous movements and shifts in time. Therefore, the proposed method M from the opposite candidates quickly sided with the improved performance of PAPR reduction is transformed (IFFT) blocks. However, the high PAPR of OFDM signals, in turn, is related to the total value of the highest salaries at the end [2] is used, affects the electrical efficiency. The decisions to reduce the impact of high PAPR, several lines of additional codes, shearing, such as literature, namely, filters and compression [3], [4] commanding and change [5], error control coding techniques are available [6] Reed Muller codes, [7] and a number of signal patterns, namely, the selected card (SLM) [8], partial sequence (PTS) [9], etc. SLM scheme to reduce PAPR, but he did not introduce distortion, is popular among all the other methods as well as easier to implement. The candidates, however, M IFFT to create a plan of action CSLM another, suffer from the complexity of the calculation. In order to reduce the calculation of the complex, and a flawless sequence of equal magnitude less complex SLM structure [10] and the proposed map and additives sequences SLM used.

This presents techniques for reducing PAPR [1]. Some, like cutting and filtering methods to reduce, Coding, and partly on the number, and a map of the selected Tone Reservation and Tone Injection, Constellation is a summary of the type described here.

3.1.3 Amplitude Clipping and Filtering

A threshold value of the IFFT signal is set in this process IFFT fast in the grip of this process and one-sided, negative signal of a sub-carrier (IFFT) amplitude established threshold values are obtained from the sub-carrier and is filtered out of the maximum average power ratio (PAPR) value. The grip of this, we chose to subcarriers digital converter (ADCs) for the power amplifier

and an analog-dependent. Amplitude for the compression part of the OFDM PAPR reduction can be carried out, at least, is a complex system. This is a technique used to reduce PAPR is simple. Clipping [8] limits the maximum value of the input signal amplitude in prison. Evaluation of maximum amplitude of a signal in this situation, and to destroy the PIN-based. This pre-cutting the value of the high qualities features allowed by the angry and the rest of the un-irritated

$$P(x) = \begin{cases} x & |x| \leq U \\ e^{j\varphi_u} & |x| > U \end{cases} \quad (3.1)$$

Where, $P(x)$ represent the amplitude value for clipping, x represent the transmit data signal during channel, $\varphi=[0 \ 2\pi]$ and U represent the clipping the signal for users.

Various methods [1] - [5] PAPR reduction is recommended simple and commonly used method of finite lower PAPR is cut to limit the signal, but it can also cause

distortion of the robbers, and the group advertisement. The code of the block according [2] with a low PAPR by encoding information into code-word to reduce the PAPR increase, but not excessive [4]. The selected mapping (SLM) and partial transmit sequence in excess of the (PTS) with a relatively small increase proposed for PAPR reduction, but there is no signal distortion. SLM-year period to mark the introduction of additional sequences, sequences, and a pre-determined sequence, that can be formed by multiplying. After that, the Group PAPR OFDM signal with a fast-sided transform (IFFT), and was selected to the opposite.

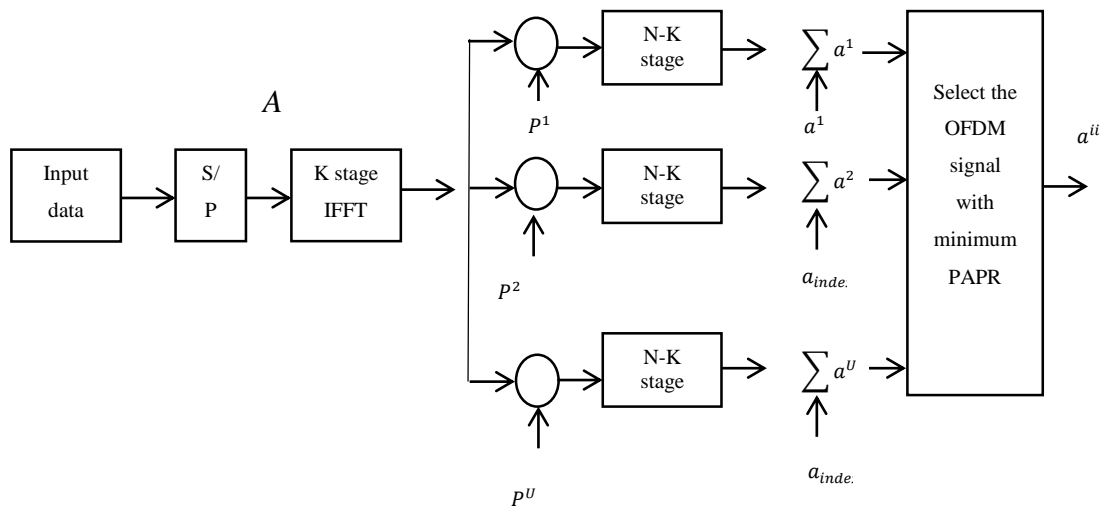

Figure 3.1: SLM for OFDM block diagram

In partial transmit sequence (PTS), The sequence of the introduction of a number of disjoint sub-blocks. IFFT is used for each sub-block and sub-blocks, coupled with a sequence of signals, they are distinct reasons after the sitting. Then, PAPR is rotating, and each package. This is more useful than the SLM partial sequence is limited to the amount in excess of the (passport), but the SLM on the complexity of the calculation of

The partial sequence (PTS) is a lot more than it has been revealed. The complexity of the calculation of the SLM stage is increased depending on the number of sequences. Carriers generally, and the OFDM system is the increase in complexity of the calculation, limiting the implementation of the SLM.

3.2 COVENANTAL SLM FOR OFDM

In Figure 3.1 show as well as traditional favorite alternative method (SLM), and Orthogonal Frequency Division multiplexing (OFDM) symbol sequences are successively carried out by multiplication. The main idea of this technique is an alternative to the original data block the development of a number of OFDM signals and OFDM signal with the minimum PAPR for the first time. However, the transmitter of the data rate of loss, and there are two main disadvantages of this method is its complexity. Under this method, the N data and statistical experts, information, data sequences, and each sequence of N by N to create a variety of images in the time domain OFDM complex IFFT N-way in the direction of change. is chosen to provide an image with a low PAPR.

In OFDM is used to reduce the PAPR is low distortion and effective method. This method name, a number will be selected from among a number of sequences shows that there is. According to the concept of discrete-time OFDM block of information, we must take into account the N number of symbols Ranking station features a number. The number of N subcarriers to be used in the case. After that, an independent candidate directions, block U is formed by increasing the number of independent stage directions. Various time-domain OFDM symbols to create a main objective of the strategy of SLM false time-domain OFDM

$$x = [x(0), x(1), \dots, x(n - 1)]^t \quad (3.2)$$

Where n is the sub-carrier for every factors at transmit signal from base station to users,

P^u represent the transmit power allocation, where $P^u = [P^1, P^2, \dots, P^{U-1}]$, $0 \leq u \leq U - 1$.

At the receiver, in case the buyer effectively dab in order to demodulate the signal, the performance of M among the candidates for a variety of series connected Littlest PAPR. In this regard, receiver and transmitter to be found in this series of effective guarantees

The stage to find out information about the selected row in the direction required. The methodology of instinct is delivered to at least the end of the side branch, the number of members will select the entire list. In practice, however, this disease can be acknowledged by sending a sequence of course. Before the end of this precious little look: sitting at the table, or any other means of access to a list of the basic steps for a way to restore it is only when there is a change or whatever other means.

The established of OFDM for transmit signal sequences can be written as

$$x^u = \prod_{n=1}^N X_n \otimes P^u \quad (3.3)$$

where \otimes means the module wise development of two paths. The phase sequence, P^u represent produced by consuming a convoluted number scale importance, $P^u = e^{j\phi_u}$ where $\phi_u = [0 \quad 2\pi]$. These unusual enter successions, x^u are then experienced Inverse fast Fourier Transform (IFFT) procedure to produce OFDM signal in the time domain. The transmit signal based on convolution SLM in PAPR is written as

$$x^u(t) = \frac{1}{\sqrt{N}} \sum_{i=0}^{N-1} X^u \cdot e^{j2\pi f_k t} , \quad 0 < t < Nt \quad (3.4)$$

where $e^{j2\pi f_k t}$ represent the achieved for OFDM signal rendering the inverse fast Fourier transform

$$a^u = arg \min_{0 < u < U-1} \left[\frac{\max(x^u(t))^2}{E|x^u(t)|^2} \right] \quad (3.5)$$

It should be noted, with signals transmitted along with the buyer side, a^u index to interpret the relevant entry. [8] Reported that increased after the increased y, PAPR reduction. At the same time, the change-sided blocks, opposite the large number of U and computational complexity increases are too high. [8] [14] the large u and the computational complexity become too high.

3.3 MODIFIED SELECTING MAPPING

A modified Selective Mapping is the proposed and conventional SLM is a much more high-Average Power Ratio (PAPR) indicated for the reduction of variation. The change in the proposed method IFF) block offers a great reduction in reverse. according to (3.3), Orthogonal Frequency Division multiplexing (OFDM) signals generated by increasing the x_n and orthogonal sinusoids IFFT, $e^{j2\pi f_k}$. These two modules, x_n and $e^{j2\pi f_k}$ are significant functions to control of the PAPR, the power symbols are calculated by

$$x^a = \frac{|x^a|^2}{2} \quad (3.6)$$

Data symbol sequences x_n are the complex form of data modulated by the digital modulation QAM to the codeword bits. To increase the probability of constellation points. This technique is limited to the M-ary modulation scheme as the circulate shift will need two or more bits in a code-word to shift the bits.

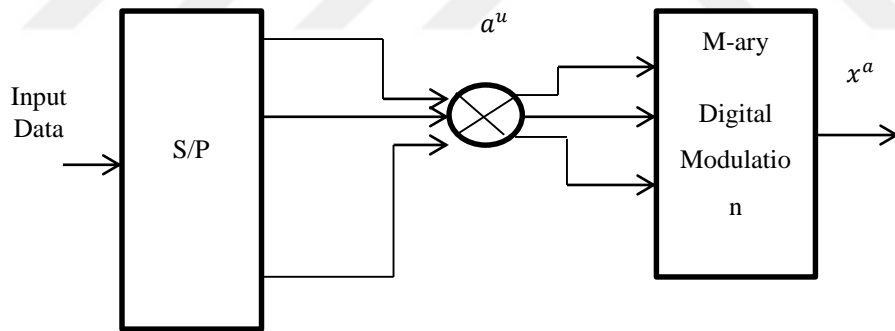

Figure 3.2: Conventional SLM for block diagram

In the discrete time domain (DTD), an the transmitted signal in OFDM signal $x = [x(0), x(1), \dots, x(n - 1)]^t$ of N carriers, Every signal of the phase orders would have component greatness to domain the high transmit power and assemblage of the enter symbol arrangement. The original phase sequence P^U represent the typically wholly one sequence I_N .

For the comfort of employment, P^U is frequently chosen between $[\pm 1]$. The OFDM transmit signal $a^u =$ IFFT with the smallest peak to average power ratio is chosen for communication, where U is written as

$$U = \arg \min_{0 < u < U-1} a^u \quad (3.7)$$

3.4 NEW SELECTING MAPPING FOR OFDM

Unlike the conventional of the sequence of each stage of the sequence of the proposed scheme, unlike conventional SLM scheme, "a so-called" intermediate signal, partly IFFT-ed sequence. The new SLM OFDM scheme is a block diagram in Fig. 3.1. In this scheme, $N = 2^u$, The inverse situation is fast decimation-in-time driver change (IFFT) on the basis of the algorithm is divided into two parts. The first part of the first stages of the IFFT and the second part is an IFFT of the remaining n-k stages. Collection of orthogonal frequency division (OFDM) signals produced by multiplying the various stages of a group of sequences P^u , $0 \leq u \leq U$ to the transitional data signal a^u subsequent to k-th period of IFFT. In comparison with conventional selective card scheme and the new scheme to be exempted from the calculation of the burden of the international signal are used in common a^u . Stage series used in the transmitter of information should be the recipient of SLM scheme. Conditional random card scheme, this index as a sign of the queue signal signal A_{index} is extra to the information symbol series A_{data} to procedure the enter symbol series $A = A_{data} + A_{index}$. Frequently the directory is encrypted for error uncovering and improvement.

3.4.1 Partial Transmit Sequence (PTS)

In PTS the passport of the frequency-domain input data, $x(K)$ Thus, the N non-overlapping sub-block in the same direction, and each sub-block Kabyldin with each other, there is a sub-part (N/M) -zero elements; with the remaining part of the zero-soft. In the sequence of partial transfer (passport), [11] features, a method of N input data sets are disjoint sub-blocks. Each sub-block sub-carriers are weighted by the impact to the sub-block stage. Stage circumstances, the combined signals are selected PAPR environmental, however, using this method, the rate of data loss.

The time-domain is partially orthogonal frequency division (OFDM) symbols accumulation of N-point complex formed by the IFFTs; With each of the (N/M) is not zero, resources, and $[N(1 - 1/M)]$ zero-bakborta. Mathematically, therefore, an OFDM symbol may be expressed as:

$$x^u(t) = \frac{1}{\sqrt{N}} \sum_{i=0}^{N-1} X^u \cdot e^{j2\pi f_k t} [IFFT x(t)] \quad (3.8)$$

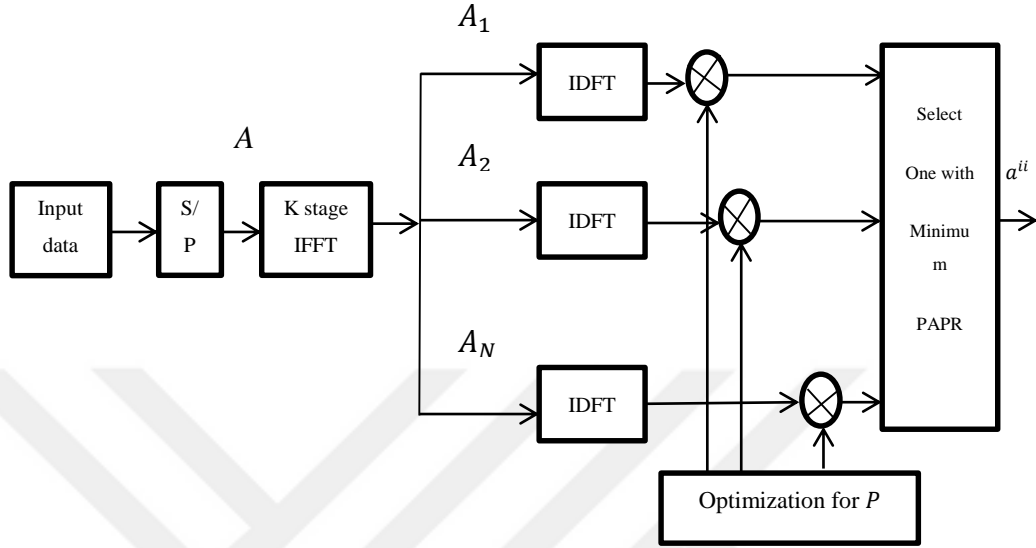

Figure 3.3: Block diagram Conventional PTS

Time domain IFFT product is growing in all directions by rotating stage, then gradually rotation, and M-OFDM symbols "weighted" according to the general introduction of the information system includes a full OFDM symbol carrying capacity.

The main issue of the passport has chosen to be very low PAPR OFDM turn directions to each of the images in the road to make an image of M is a suitable stage of the action. This is ideal to reach an agreement with the trials considered in the calculation of each company in order to find the PAPR is required. PTS-based PAPR reduction scheme is part of the procedure.

3.5 SELECTED MAPPING (SLM) COMBINED WITH CLIPPING

This is where we first IFFT signal compression method and the SLM used. The following is the procedure. First, the bit-source mapping of serial bits, such as coma, for example, can be resilient to some degree (orthogonal amplitude map of the formulation) or PSK (phase shift), etc.

After a map compression technology, which are made to turn off the signal exceeds the threshold value. Thus, the loss of data this data compression, then the user bit-stream serial-to-parallel and parallel streams are converted.

This equivalent data signal sequences is increased with the phase signals $(P(1), P(2), \dots, \dots, P(U))$. A sub-carrier path is grown due to multipath transmission for subcarrier aware with every single of the U paths $P(U)$, then subsequent to section section $a^u = A_N P^U$, $a^u = IDFT = IDFT x(t)$. Nonetheless totally U different sub-carrier directions are distorted keen on time province to grow $a = a.n$ and lastly that communicate structure with the smallest PAPR is selected.

3.6 SELECTED MAPPING (SLM) COMBINED WITH CODING

The SLM calculation of highly complex disorders. Thus, the demand for high-speed operation of complex hardware, which in turn increases the cost of implementation at

The transmitter system and electricity consumption. In order to overcome these restrictions, we have proposed to the complexity of SLM page below. However, SLM-PAPR reduction performance of every element on the rotating stage of the cycle, and is determined by the total number of candidates. Therefore, PAPR reduction stage with the following list of auto property, namely, Riemann, page Rima and chaotic sequences of our proposed method is used.

Similarly, here, we are the first encoding method, and then applies the selected mapping technique. Here, we use a method of encoding is convolutional encoding. Whereas the convolutional encoder and encodes it using modulated signal modulated bit. And bits are converted to forgive a serial-parallel and parallel flow. This has increased the flow of information about the phase sequence $(P(1), P(2), \dots, \dots, P(U))$. A sub transferor course A is increased subcarrier informed with every one of the U routes $P(U)$, then ensuing to module A $n(u) = A_n P_n(u)$, $a(u) = IDFT\{A(U)\}$. Afterward every U substitute sub-carrier directions are converted into time domain to grow $\tilde{a} = a n$ and Finally, the Group selected list of PAPR. convolutional Decoder in order to decode the information and initial data are used.

3.7 POWER SAVINGS THROUGH SELECTED MAPPING

The average input signals peak electricity must be taken into account to reduce the influence of the distortion of the OFDM system needs to do, and should be used to introduce a re-cap (IBO). Can achieve the desired output power IBO is a measure to reduce the introduction of electricity. IBO average amount of electricity used in connection with peak efficiency and PAPR η , great

PAPR consequence in growing IBO and reducing η . IBO with a probability equal to the PAPR. OFDM system may be used in the earnings performance [13],

$$\eta = \frac{P_{out}}{P_{dc}} \quad (3.9)$$

The Class amplifiers are inefficient amplifiers, for example, range between 10 to 25%, the highest efficiency of up to 50%, and increase their effectiveness. Thus, the ideal linear power amplifier should be used to maintain saturation. This is an ideal power amplifier.

$$\eta = \frac{0.5}{PAR} \quad (3.10)$$

Energy saving in electricity consumption can be defined as P_{dc} to the efficiency η ,

$$P_{dc} = \frac{P_{out}}{\eta} \quad (3.11)$$

Now, by replace with (3.9) into (3.10), it able to reason out this score,

$$P_{dc} = \frac{P_{out}}{\frac{1}{2*PAR}} \quad (3.12)$$

$$P_{dc} = 2 * PAR * P_{out} \quad (3.13)$$

Therefore, the other is written to the effectiveness of the protective power,

$$P_{saving} = 2 * P_{out}(PAR_1 - PAR_2) \quad (3.14)$$

To compute power savings gain g_s , occupancy us signify that are able to improve the power saving gain g_s as the percentage of savings power the production influence,

$$g_s = \frac{P_{saving}}{P_{out}} \quad (3.15)$$

Based on the Eq.(3.13) and Eq.(3.14), that can streamlined the gain

$$g_s = \frac{2*P_{out}(PAR_1 - PAR_2)}{P_{out}} \quad (3.16)$$

Therefore, the investments gain g_s as the consequence of Peak to Average Power Ratio can be witting as

$$g_s = 2 * P_{out}(PAR_1 - PAR_2) \quad (3.17)$$

3.8 SUMMARY

In this chapter, The SLM calculation of highly complex disorders. Thus, the demand for high-speed operation of complex hardware, which in turn increases the cost of implementation at the transmitter system and electricity consumption. In OFDM is used to reduce the PAPR is low distortion and effective method. The average input signals peak electricity must be taken into account to reduce the influence of the distortion of the OFDM system needs to do, and should be used to achieve the desired output power IBO is a measure to reduce the introduction of electricity.

4. SIMULATIONS RESULTS

4.1 OVERVIEW

In chapter 4, we simulated the orthogonal frequency division multiplexing system with several numbers of subcarriers and with sub blocks based on SLM using MATLAB simulation. Analysis was done for bit error rate performance of the simulated OFDM, the complementary cumulative distribution function (CCDF) schemes for several PAPR decrease procedures are plotted. This chapter proposes a novel peak to average power ratio (PAPR) reduction with used the SLM system that involves no margin knowledge in orthogonal frequency division multiplexing (OFDM) systems.

4.2 IFFT SIGNAL FOR CLIPPING

Figure 4.1 demonstrates the invers fast Fourier transform (IFFT) productivity of transmit signal, it be able to be realized that it includes great PAPR as the peak power is greatly huger than the average transmit power. Therefore, currently after we concern clipping system to this transmit signal, a segment of the signal exceeding the entrance is clipped off providing decreased peak to average power ratio (PAPR), we repaired the beginning to be 0.3 and the calculation following clipping.

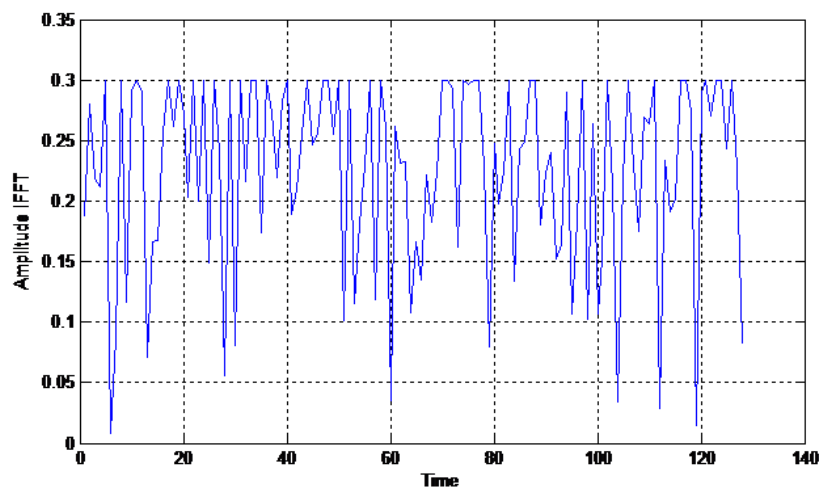

Figure 4.1: Related of Amplitude IFFT with time after clipping

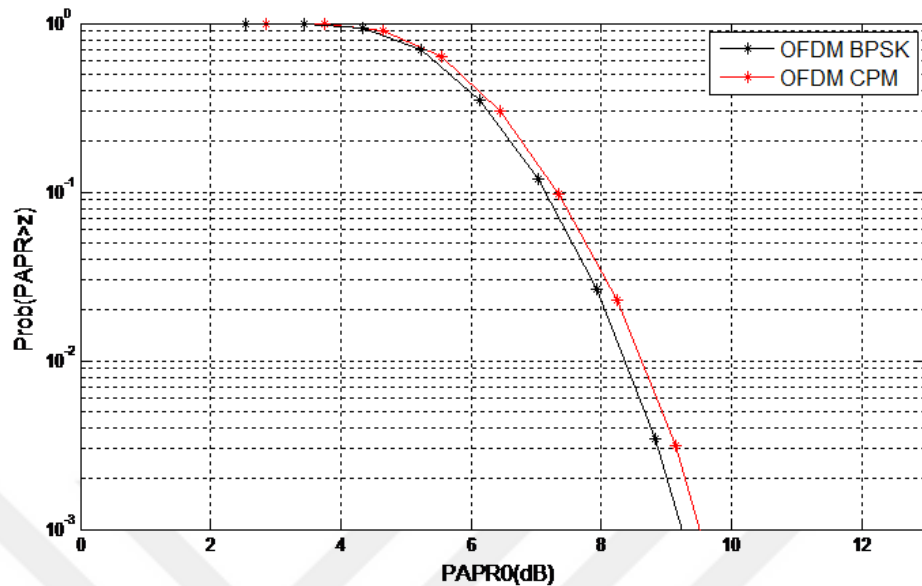

Figure 4.2: Related of PAPR for CPM

First the orthogonal frequency division multiplexing (OFDM) system with the systems in the top of one of the average electricity is examining (PAPR)

OFDM using binary phase-shift keying in (BPSK) with a continuous phase frequency OFDM (CPM) by convolution. Figure 4.2 shows OFDM BPSK, OFDM in the world with a brand PAPR. PAPR values of average power ratio of the peak of the BPSK scheme (PAPR), optimized codes with the PAPR can be decreased, and further, and further demonstrates that it can be reduced. This project is implemented with the continuous phase frequency in OFDM and use BPSK. For BPSK technique SLM PAPR reduction based on the method used, is shown in Figure 4.2. We chose to use card (SLM) PAPR is reduced too much, should be noted. The complexity of the system, increased use of the SLM and the analog to digital converter or digital to analog converter (ADC / DAC), and provides a good sign for the power amplifiers.

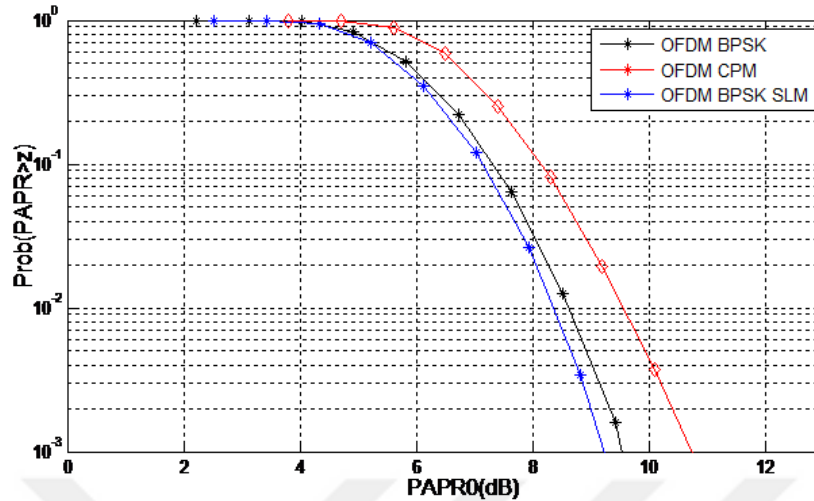

Figure 4.3: Related of PAPR for SLM

Figure 4.3 shows the number of subcarriers other SLM method together with an additional portion of the distribution function for the PAPR. Subcarrier for 128 at the plot of the show, the 64 and 32-subcarriers for the cumulative distribution function (CCDF) bent complement each other, and that the number of PAPR subcarriers a little bit of

OFDM is the general trend. SLM and is known to reduce the PAPR. The power reduction was small at used SLM while at used continuous phase modulation (CPM) the peak to average power ratio it will be increases more than OFDM BPSK with used selective mapping. The probability of error increases with used continuous phase modulation.

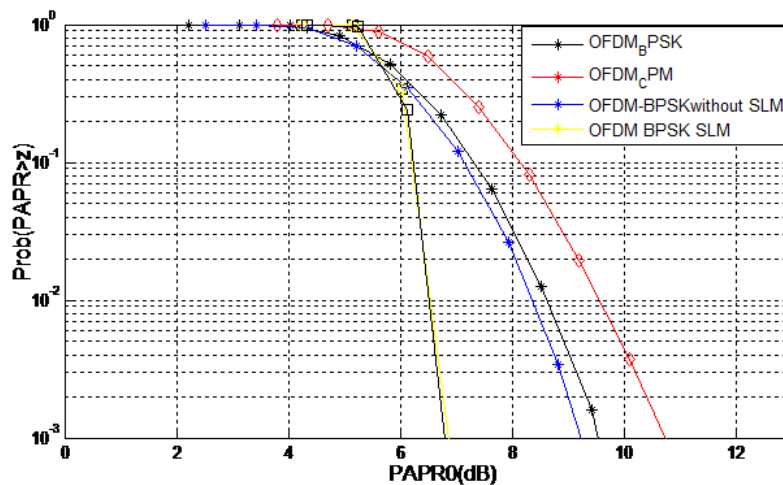

Figure 4.4: Related of PAPR with and without SLM

Figure 4.4 PAPR cumulative distribution function (CCDF) shows the proposed team for the PAPR techniques. We cut and SLM method, combined with the code and its behavior analysis. The code of the above plot CCDF and looked more likely SLM curve ($PAPR > Z$) axis, and at least could see the PAPR. We cut alone or together with the code, instead of using SLM conclude, therefore, a good combination, can provide better PAPR performance SLM Plus code will be also it is greatest when the combination is SLM coding.

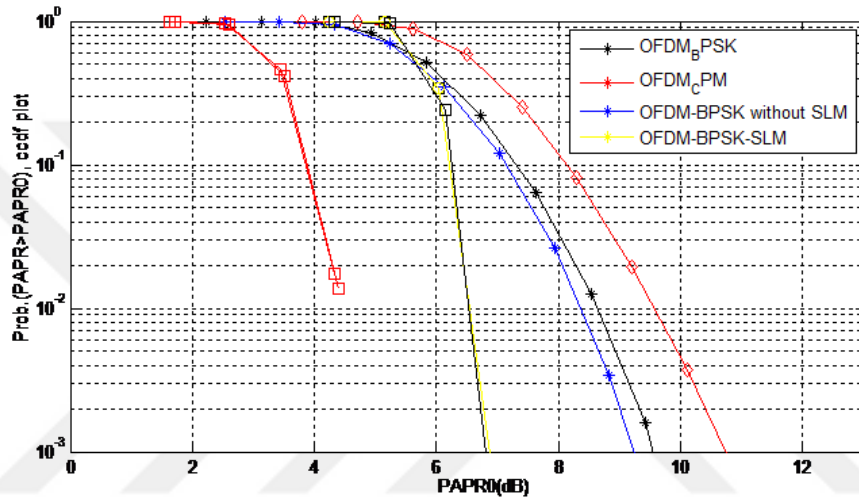

Figure 4.5: Related of PAPR for CCDF with and without SLM

From Figure 4.5 show the related between probability of ($PAPR > z$) versus $PAPR_0$. The techniques of OFDM with BPSK for SLM provide the performance power more than at used the OFDM without BPSK for SLM. According to the PAPR complementary cumulative distribution function (CCDF) in this Figure provide the high quality of power (minimize the PAPR), at used OFDM BPSK with SLM based on used clipping that enhance the channel at transmit power based on used the OFDM BPSK with SLM.

4.3 PERFORMANCE ANALYSIS AT INCREASES NUMBER OF SUBCARRIER

From Figure 4.6, the techniques of SLM provide the good values of peak to average power ratio due to more number of transmitted antennas $N = 256$. The new techniques of SLM was able to improve the transmission performance by eliminate the inter- symbol interference, interleaving, and inter carrier interference. The probability of $PAPR > PAPR_0$ provide the high power based on used the SLM with coding.

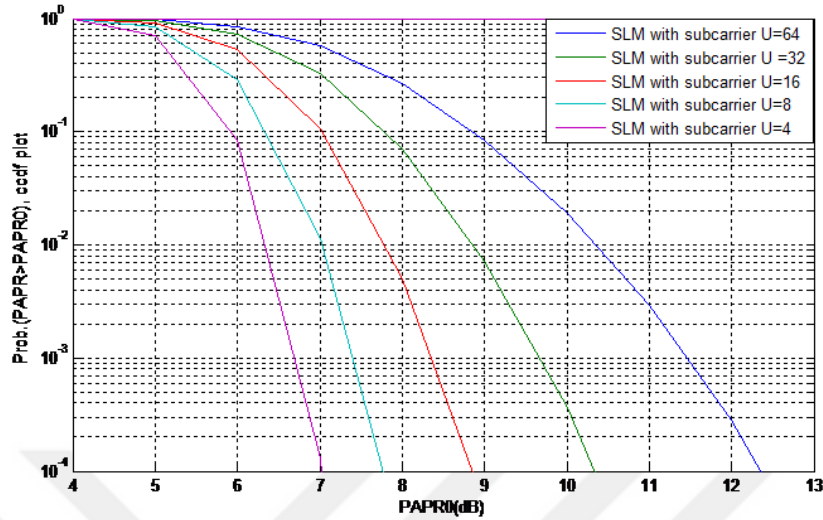

Figure 4.6: Related of PAPR for CCDF when $N=256$

The OFDM signals orthogonal Modulation signal amplitude and the frequency spectrum of the radio frequency spectrum shown in figures 4.6 and 4.7, respectively. Figure 4.9 shows 256 subcarriers and M-modulated OFDM signals in time domain, and consistent with the scale of 16 to add to subcarriers of the OFDM signal is a peak height of the average power can be seen in the picture, and the same stage. RF and wages, as well as to reduce the effectiveness of the inter-carrier interference, because this is a high PAPR is a very important point. Thus, SLM scheme PAPR is a way to reduce the impact of this technology are discussed in the next chapter. This section will reduce the PAPR and this is a great map of the selected PAPR reduction scheme is that it can be discussed. Figures 4.6, 4.7, 4.8, 4.9, and U, respectively, phase sequences and subcarriers N. Using the equation of different values (3.13) and reducing the maximum electric power ratio (PAPR) of the selected mapping (SLM) scheme that shows the efficiency of the highest figures U good PAPR reduction can be cleaned by increasing the number of step-by-step sequences. (3.11) OFDM symbol in the picture, for example, a portion of a PAPR reduction curve for $N = 62$. From the picture, the better the performance of the PAPR reduction is the threshold necessary for $U = 4$, but assuming there is no SLM, $U = 32, 16, 8$, is necessary for the performance of PAPR reduction, but that it can be seen that 10.5 performance.

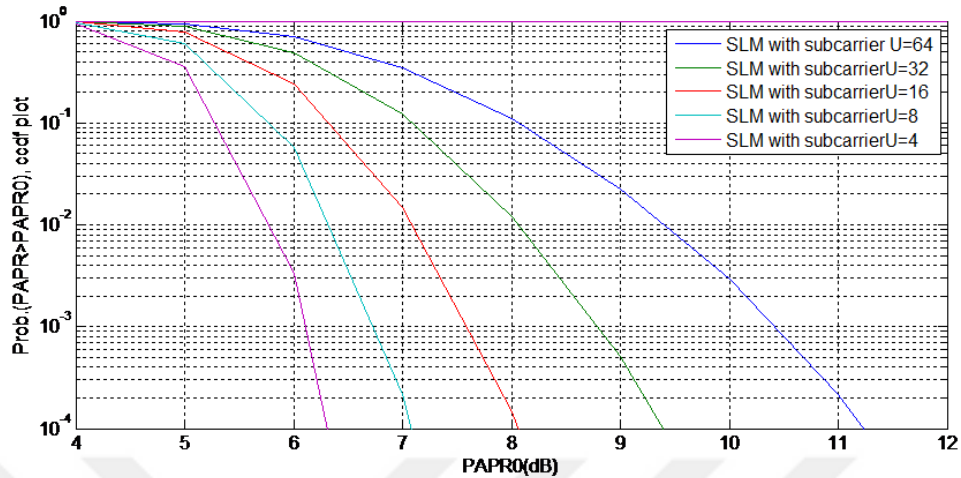

Figure 4.7: Related of PAPR for CCDF when N=64

Figure 4.7 show the related between the $\text{Prob}(\text{PAPR} > \text{PAPR}_0)$ versus PAPR_0 according of the SLM with subcarrier. We noted from the Figure 4.7 at increases the number of subcarrier from $U=4$, the PAPR_0 equal to (6.3dB), while at increased the number of subcarrier from (8, 16, 32, 64) the PAPR_0 it will be increases directly from (7.2, 8.1, 9.3, 11.2) when the number of antennas = 64, due to more hardware and radio frequency chain it will be consume more of power in addition to the channel it will be critical at increases transmitted signal depend on the number of transmitted antennas.

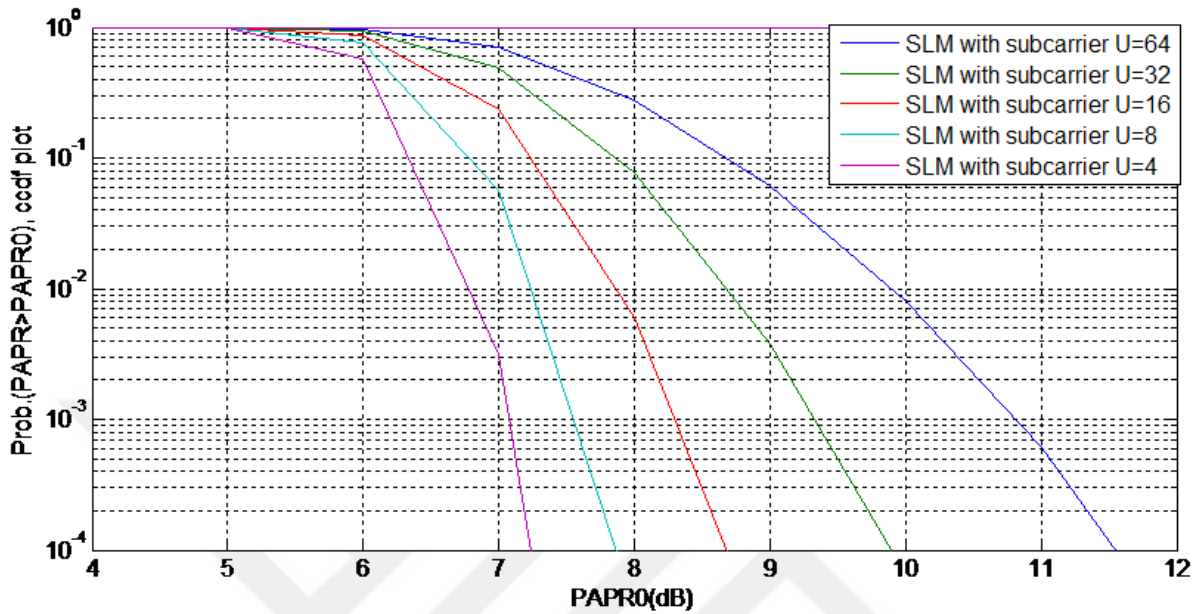

Figure 4.8: Related of PAPR for CCDF when N=128

From Figure 4.8, when the number of antenna arrays increased to N=128, in the case we can noted the PAPR0 it will be increases directly compare when the number of antenna arrays N=64. Therefore, the related of complementary cumulative distribution function (CCDF) for proposed PAPR technique at increases the number of subcarrier it will be increases at increase number of transmitted antennas N=128, where when the number of subcarrier from U= 4, the PAPR0 equal to (7 dB), while at increased the number of subcarrier fro(8, 16, 32, 64) the PAPR0 it will be increases directly from (7.7, 8.4, 9.7, 11.4) when the number of antennas = 128, due to more hardware and error correction in the system that will be make difficult at used the SLM.

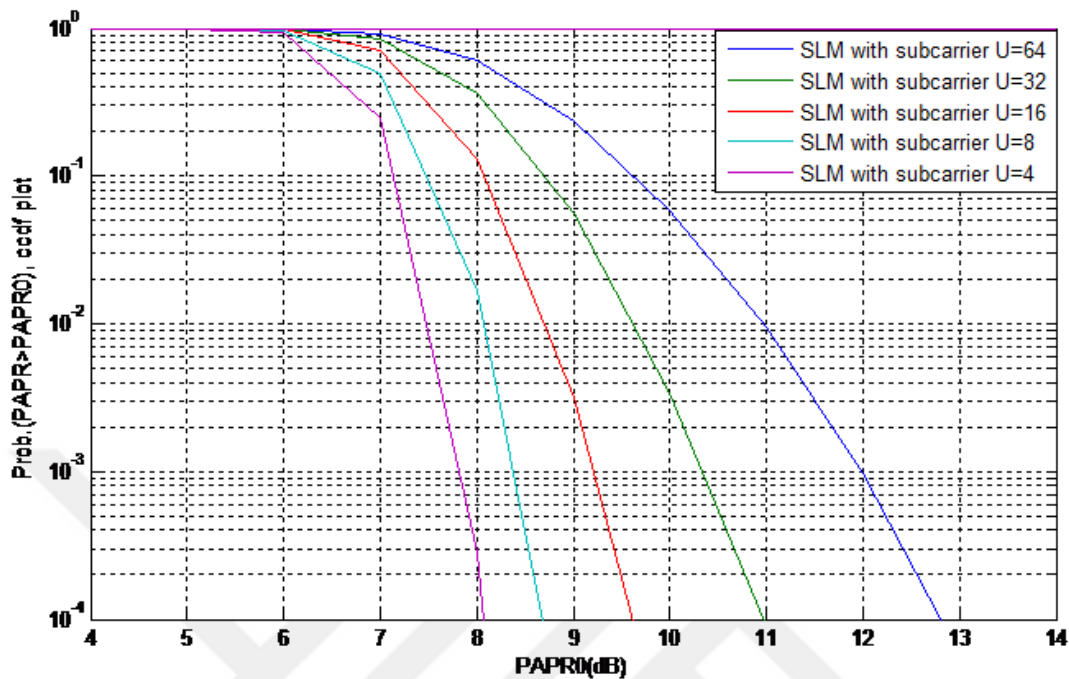

Figure 4.9: Related of PAPR for CCDF when N=512

The same set of OFDM subcarriers $U=64$ and $M=512$ east of the multiple number of antennas transmitted modulated OFDM signal, Figure 4.9 shows the time domain, as Figure 4.9 OFDM signal consists of a high peak to average power, consistent with the same stage of the subcarriers expense. From Figure 4.7, 4.8 and 4.9, we have three of them due to a system error subcarrier granted an average increase of electricity increases. In addition, the data block sizes for each sign of the degree and the light from the group of clipping noise.

4.4 CHAPTER SUMMARY

In this section, for chapter summary the simulation results, approaching the capacity of the simulation results of the SLM for the code on the basis of speed compared to other metrics depend on the results obtained. Based on SLM using MATLAB simulation. Analysis was done for bit error rate performance of the simulated OFDM, the complementary cumulative distribution function (CCDF) schemes for several PAPR decrease procedures are plotted. This chapter proposes a novel peak to average power ratio (PAPR) reduction with used the SLM system that involves no margin knowledge in OFDM. there would be great sum rate base on evaluate both of high performance of power efficiency and lower bit error rate. The demand for

high-data rate and bit error rate, improve the efficiency of compromising between the trade-off can be performed with a carrier frequency. Frequency selective fading environment, it is a little more with a bit error rate performance for the truck speed is very difficult to achieve a high data rate. multi-carrier systems with a variety of methods to reduce peak to average power ratio (PAPR) in carrying out the research. In addition to reducing the PAPR and salaries



5. CONCLUSIONS

5.1 CONCLUSIONS

From OFDM system with selective mapping has been explained in this thesis. This is due to the OFDM system, there are advantages that supports a nationwide communications system. For example, a flat-fading channels, the ability of a system for selecting the fading frequency channels. Also, the international sign of inters carrier interference into adulthood. In addition, the channel conditions, system flexibility, and design to satisfy these. The average ratio of the electrical problem and discussed, as well as influence on the transmitted signal. Methods such as the ratio of average power and signal distortion, Coding Schemes and Marker-fighting techniques, there are many proposals to solve the maximum reduction methods. A map of the selected method (SLM) was the main topic of the project. Explained SLM and SLM showed that a majority of the reduction method. As well as for energy saving is achieved through the selected card. No part of this project and the SLM OFDM symbol shows the results of the coach. The results of the coach is only possible with the cards selected PAPR reduction scheme, stated that, while U, which can be obtained by increasing the number of PAPR reduction step sequences. In addition, Multicarrier, a noise variance for the

provision of high-speed communication channels is a very attractive strategy. PAPR issue must be tended in order to create a framework for multicarrier is one of the most important issues. In this case, we have to multicarrier several PAPR reduction procedures. PAPR reduction strategy proposed in the literature, all of them, perhaps, with the complexity of the calculation system for transmitting data rate, and can PAPR due to the danger of diminishing. We have explored some of the ways to reduce the high PAPR system. We are cutting the proposed joint programs, such as SLM and the SLM, along with good PAPR results in code, this approach was successful. Amplitude loss of data, plus the results of the SLM technique, while cutting the selected mapping (SLM), the code will not affect the data. SLM combined smoking and comparing SLM line of code methods From United SLM hybrid coding, we can conclude to be effective in reducing the PAPR.

We noted from the Figure 4.7 at increases the number of subcarrier from $U=4$, the PAPR0 equal to (6.3dB), while at increased the number of subcarrier from (8, 16, 32, 64) the PAPR0 it will be

increases directly from (7.2, 8.1, 9.3, 11.2) when the number of antennas =64, due to more hardware and radio frequency chain it will be consume more of power in addition to the channel it will be critical at increases transmitted signal depend on the number of transmitted antennas.

5.2 FUTURE WORK

The following are recommendations of exciting topics that can be followed as additions of this thesis

- Enhancing high transmitted power efficiency base n used the technique selected mapping.
- Used phase sequences for CPM to reduce the clipping and inter-symbol interference for selected mapping detection.

REFERENCES

- [1] T. Hwang, C. Yang, G. Wu, S. Li, G.Y. Li, OFDM and its wireless applications: a survey, *IEEE Trans. Veh. Technol.* 58 (4) (2009) 1673–1694.
- [2] Ghaffoori AJ. PAPR Reduction In OFDM System Using Adaptive Hybrid Technique. In *IOP Conference Series: Materials Science and Engineering* 2019 May (Vol. 518, No. 5, p. 052021). IOP Publishing.
- [3] Ali M, Rao RK, Parsa V. PAPR Reduction in OFDM System Using New Method for Generating Pseudo-Random Sequence for SLM Technique. In 2018 IEEE Canadian Conference on Electrical & Computer Engineering (CCECE) 2018 May 13 (pp. 1-4). IEEE.
- [4] Hardas BM, Pokle SB. Optimization of peak to average power reduction in OFDM. *Journal of Communications Technology and Electronics.* 2017 Dec 1;62(12):1388-95.
- [5] Bahra N, Abed Hodtani G. A modified SLM technique for PAPR reduction in OFDM systems by using a novel phase sequence. *International Journal of Electronics Letters.* 2018 Jan 2;6(1):90-7.
- [6] Wu Y, He C, Zhang Q, Sun Y, Wang T. Low-complexity recombined SLM scheme for PAPR reduction in IM/DD optical OFDM systems. *Optics express.* 2018 Nov 26;26(24):32237-47.
- [7] Seung Hee Han, Jae Hong Lee, An overview of peak-to-average power ratio reduction techniques for multicarrier transmission, *IEEE Wirel. Commun.* 12 (2) (2005) 56–65.
- [8] Hideki Ochiai, Hideki Imai, Performance analysis of deliberately clipped OFDM signals, *IEEE Trans. Commun.* 50 (1) (2002) 89–101.
- [9] Xiaodong Li, Leonard J. Cimini Jr, Effects of clipping and filtering on the performance of OFDM, *IEEE 47th Vehicular Technology Conference* (1997) 3.

- [10] Wang L, Cao Y. Improved SLM for PAPR reduction in OFDM systems. In 2009 International Workshop on Intelligent Systems and Applications 2009 May 23 (pp. 1-4). IEEE.
- [11] Gay M, Lampe A, Breiling M. A hybrid PAPR reduction scheme for OFDM using SLM with clipping at the transmitter, and sparse reconstruction at the receiver. In 2014 IEEE 11th International Multi-Conference on Systems, Signals & Devices (SSD14) 2014 Feb 11 (pp. 1-6). IEEE.
- [12] Athinarayanan Vallavaraj, Brian G. Stewart, David K. Harrison, An evaluation of modified 1-Law companding to reduce the PAPR of OFDM systems, *AEU-Int. J. Electron. Commun.* 64 (9) (2010) 844–857.
- [13] V.P. Jimenez, M.J. Garcia, M.P. Sanchez-Fernandez, A.G. Armada, Efficient implementation of complementary Golay sequences for PAR reduction and forward error correction in OFDM-based WLAN systems, *AEU-Int. J. Electron. Commun.* 62 (9) (2008 Oct 1) 683–694.
- [14] J.A. Davis, J. Jedwab, Peak-to-mean power control in OFDM, Golay complementary sequences, and Reed-Muller codes, *IEEE Trans. Inf. Theory* 45 (7) (1999) 2397–2417.
- [15] Robert W. Bauml, F.H. Fischer. Robert, B. Huber. Johannes, Reducing the peak-to-average power ratio of multicarrier modulation by selected mapping, *Electron. Lett.* 32 (22) (1996) 2056–2057.
- [16] J. Leonard. Cimini Jr, Nelson R. Sollenberger, Peak-to-average power ratio reduction of an OFDM signal using partial transmits sequences, *IEEE Commun. Lett.* 4 (3) (2000) 86–88.
- [17] Chih-Peng Li, Sen-Hung Wang, Chin-Liang Wang, Novel lowcomplexity SLM schemes for PAPR reduction in OFDM systems, *IEEE Trans. Signal Process.* 58 (5) (2010) 2916–2921.
- [18] H.B. Jeon, J.S. No, D. Shin, J, A low-complexity SLM scheme using additive mapping sequences for PAPR reduction of OFDM signals, *IEEE Trans. Broadcasting* 57 (4) (2011) 866–875.

- [19] B Abolfazl Ghassemi, T. Aaron Gulliver, Partial selective mapping OFDM with low complexity IFFTs, *Commun. Lett., IEEE* 12 (1) (2008) 4–6.
- [20] Chin-Liang Wang, Ming-Yen Hsu, Yuan Ouyang, A lowcomplexity peak-to-average power ratio reduction technique for OFDM systems, *Global Telecommunications Conference, 2003. GLOBECOM'03* 4 (2003).
- [21] S.H. Wang, J.C. Sie, C.P. Li, Y. Chen, F, A low-complexity PAPR reduction scheme for OFDMA uplink systems, *IEEE Trans. Wirel. Commun.* 10 (4) (2011) 1242–1251.
- [22] Robert FH Fischer, Widely-linear selected mapping for peak toaverage power ratio reduction in OFDM, *Electron. Lett.* 43 (14) (2007).
- [23] L. Yang, Y.M. Siu, K.K. Soo, S.W. Leung, S.Q. Li, Lowcomplexity PAPR reduction technique for OFDM systems using modified widely linear SLM scheme, *AEU-Int. J. Electron. Commun.* 66 (12) (2012) 1006–1010.
- [24] Lin Yang, Hu. Wu-Jun, Kwok-Kai Soo, Yun-Ming Siu, Swapped SLM scheme for reducing PAPR of OFDM systems, *Electron. Lett.* 50 (22) (2014) 1608–1609.
- [25] Meza C, Lee K, Lee K. PAPR Reduction in single carrier FDMA uplink system using parametric linear pulses. In *Proceedings International Conference on ICT Convergence (ICTC 2011)*, Seoul, Korea, Sept. 2011; 424–429.
- [26] Takei Y, Ohtsuki T. Uplink pre-equalization using mmse prediction for TDD/MC-CDMA systems. In *Proceedings IEEE International Symposium on Personal Indoor and Mobile Radio Communications (PIMRC 2005)*, Berlin, Germany, Sept. 2005; 291-295.
- [27] Kawamura T, Kishiyama Y, Sawahashi M. Performance of star 16QAM schemes considering cubic metric for uplink DFT-Precoded OFDMA. *IEICE Transactions on Communications* 2014; E97-A: 18–29.
- [28] Eom SS, Nam HW, Ko YC. Low-complexity PAPR reduction scheme without side information for OFDM systems. *IEEE Transactions Signal Processing* 2012; 60(7): 3657–3669..

- [29] Wen-Xiang Lin_, Jia-Chin Lin[†] and Yu-Ting Sun[‡], “Modified Selective Mapping Technique for PAPR Reduction in OFDM Systems”, 12th International Conference on ITS telecommunications, 2012.
- [30] Han SH, Lee JH. Modified selected mapping technique for PAPR reduction of coded OFDM signal. *IEEE transactions on broadcasting*. 2004 Sep 27;50(3):335-41.
- [31] Boonkajay A, Adachi F. Selected mapping technique for reducing PAPR of single- carrier signals. *Wireless Communications and Mobile Computing*. 2016 Nov;16(16):2509-22.
- [32] Sudha V, Kumar DS. Low complexity PAPR reduction in SLM-OFDM system using time domain sequence separation. *Alexandria engineering journal*. 2018 Dec 1;57(4):3111-5.
- [33] Boonkajay A, Obara T, Yamamoto T, Adachi F. Excess bandwidth transmit filtering based on minimization of variance of instantaneous transmit power for low PAPR SC-FDE. *IEICE Transactions on Communications* 2015; E98-B(04): 673–685.
- [34] Bisht M, Joshi A. Various techniques to reduce PAPR in OFDM systems: A survey. *International Journal of Signal Processing, Image Processing and Pattern Recognition*. 2015;8(11):195-206.
- [35] Sudha V, Kumar DS. Low complexity PAPR reduction in SLM-OFDM system using time domain sequence separation. *Alexandria engineering journal*. 2018 Dec 1;57(4):3111-5.
- [36] Zhu, Xiaodong, et al. "Simplified Approach to Optimized Iterative Clipping and Filtering for PAPR Reduction of OFDM Signals." (2013): 1-11.
- [37] Huang, Xiao, et al. "Companding transform for reduction in peak-to-average power ratio of OFDM signals." *Wireless Communications, IEEE Transactions on* 3.6 (2004): 2030-2039.
- [38] Cimini Jr, Leonard J., and Nelson R. Sollenberger. "Peak-to-average power ratio reduction of an OFDM signal using partial transmit sequences." *Communications Letters, IEEE* 4.3 (2000): 86-88.

- [39] Bauml, R.W.; Fischer, R.F.H.; Huber, J.B., Reducing the peak-to-average power ratio of multicarrier modulation by selected mapping, *Electronics Letters*, Vol. 32 no. 22, pp. 2056,2057,24Oct1996.
- [40] Hasan, M. M. (2013). VLM precoded SLM technique for PAPR reduction in OFDM systems. *Wireless personal communications*, 73 (3), 791-801.
- [41] Jeon, H. B., No, J. S., & Shin, D. J. (2011). A low-complexity SLM scheme using additive mapping sequences for PAPR reduction of OFDM signals. *Broadcasting, IEEE Transactions on*, 57(4), 866-875.
- [42] Wang, S. H., Sie, J. C., Li, C. P., & Chen, Y. F. (2011). A low-complexity PAPR reduction scheme for OFDMA uplink systems. *Wireless Communications, IEEE Transactions on*, 10(4), 1242- 1251.
- [43] Li, C. P., Wang, S. H., & Wang, C. L. (2010). Novel low-complexity SLM schemes for PAPR reduction in OFDM systems. *Signal Processing, IEEE Transactions on*, 58(5), 2916-2921.
- [44] Sudha, V., Bhukya Anilkumar, and D. Sriramkumar. "Low-complexity modified SLM method for PAPR reduction in OFDM systems." In *Electronics and Communication Systems (ICECS), 2015 2nd International Conference on*, pp. 1324-1328. IEEE, 2015.

APPENDIX A

MATLAB CODE FOR BER FOR EB/N0 MODULATION

clear all

close all

```
clear all;close all
zdb= [0:1:12] ;
z= 10.^(zdb/10);
U = [1, 2, 4, 8, 16]; N=64;
p=ones (length (z), 12);
for j=1:length(U);
p(:,j)= (1-(1-exp(-(z))).^(2.8*N)).^U(j);
semilogy(zdb,p); grid on ;legend('SLM with subcarrier U=4','SLM with
subcarrier U=8','SLM with subcarrier U=16','SLM with subcarrier U=32','SLM
with subcarrier U=64')
axis ([4 12 10^-4 1]);
hold on
ylabel('Prob.(PAPR>PAPR0), ccdf plot ')
xlabel('PAPR0 (dB) ')
end
```

APPENDIX B

MATLAB CODE BER FOR BIT/ RECEIVE ANTENNA ARRAY

```
clear all %Clear all variables
%close all %Close all figures

EbNodB=10; %EbNo on dB scale
EbNo=10^(EbNodB/10); %EbNo on linear scale
N_vector=2:2:18; %Rx array length range
M=16; %Tx array length (or users)

for j=1:length(N_vector) %Varying the length of the receive array
    N=N_vector(j); %Selecting a value of N

    R_MS=eye(M,M); %Initializing R_MS
    R_BS=eye(N,N); %Initializing R_BS

    for p=1:M
        for q=1:M
            R_MS(p,q)=exp(-abs(p-q)); %Correlation coefficient
        end
    end

    for p=1:N
        for q=1:N
            R_BS(p,q)=exp(-abs(p-q)/10); %Correlation coefficient
        end
    end

    for k=1:1000 %This number may be increased
        [ber]=Massive_MIMO(M,N,R_MS,R_BS,EbNo); %Main function
        BER_array(k)=ber; %Storing the BER in the array
    end

    BER_total(j)=mean(BER_array); %Calculating the mean BER for each N
end

semilogy(N_vector, BER_total, 'ko-') %Plot on log scale
xlabel('Receive Array Size(N)') %X-label
ylabel('BER') %Y-label
hold on %Hold on
grid on %Grid on
```

APPENDIX C

MATLAB CODE BER FOR MINIMUM SHIFT KEYING

```
%%%%%%%%%%%%%%%%%%%%%%%%%%%%%%%%%%%%%%%%%%%%%%%%%%%%%%%%%%%%%%%%%%%%%%%%%
%      MINIMUM SHIFT KEYING      %
%      GENERALIZED MATRIX BASED  %
%      BER OF MSK IN RAYLEIGH FADING %
%      www.raymaps.com          %
%%%%%%%%%%%%%%%%%%%%%%%%%%%%%%%%%%%%%%%%%%%%%%%%%%%%%%%%%%%%%%%%%%%%%%%%%
clear all
close all

Ns=4;
Nbits=1e6;
Nstat=100;
Eb=Ns;
EbNodB=10;

% MODULATION

bits_in=round(rand(1,Nbits));
differential_bits=abs(diff([0, bits_in]));
bipolar_symbols=differential_bits*2-1;
symbols_oversampled=(ones(Ns,1))*bipolar_symbols;
symbols_oversampled=(1/Ns)*transpose(symbols_oversampled(:));
cumulative_phase=(pi/2)*cumsum(symbols_oversampled);
tx_signal=exp(i*(cumulative_phase));

% CHANNEL (NOISE AND FADING)
EbNo=10^(EbNodB/10);
sigma=sqrt(Eb/(2*EbNo));
AWGN_noise=randn(1,Ns*Nbits)+i*randn(1,Ns*Nbits);
ray_chan=(1/sqrt(2))*(randn(1,Nbits/Nstat)+i*randn(1,Nbits/Nstat));
ray_chan_mat=ones(Nstat*Ns,1)*ray_chan;
ray_chan_vec=transpose(ray_chan_mat(:));
rx_signal=ray_chan_vec.*tx_signal+sigma*AWGN_noise;

% DEMODULATION (EQUALIZATION, CORRELATION, DECISION)
rx_signal=rx_signal.*conj(ray_chan_vec);

sin_waveform=sin(pi/(2*Ns):pi/(2*Ns):pi);
rx_real=[real(rx_signal(Ns+1:end)), zeros(1,Ns)];
rx_imag=[imag(rx_signal(1:end))];
rx_I_metric=sin_waveform*reshape(rx_real, 2*Ns, Nbits/2);
rx_Q_metric=sin_waveform*reshape(rx_imag, 2*Ns, Nbits/2);

n=1:Nbits/2;
rx_I_metric=(-1).^(n+1).*rx_I_metric;
rx_Q_metric=(-1).^(n+1).*rx_Q_metric;
rx_combined=[rx_Q_metric; rx_I_metric];
rx_combined=transpose(rx_combined(:));
```

```

demodulated_symbols=sign(rx_combined);
bits_out=demodulated_symbols*0.5+0.5;

%BER CALCULATION
ber_theoretical=0.5*(1-sqrt(EbNo/(EbNo+1)))
ber_simulated=sum(bits_out==bits_in)/Nbits
plot(ber_theoretical);hold on
plot(ber_simulated,'r');hold off
semilogy(ber_theoretical,'r-', ber_simulated,'k--') %Plot on log scale
xlabel('Receive Array Size(N)') %X-label
ylabel('BER') %Y-label
hold on %Hold on
grid on

%%%%%%%%%%%%%%%%%%%%%%%%%%%%%%%%%%%%%%%%%%%%%%%%%%%%%%%%%%%%%%%%%%%%%%%%

nos=32;%No. of subcarriers
nob=10^5;%No. of blocks
PAPRdb_BPSK_SLM=zeros(length(nos),nob);% initializing the PAPRdb matrix
for i=1:length(nos)
%source bit generation
c=2.*(randi([0,1],nob,nos))-1;
c=c.';
%c=(randsrc(nob,nos(i))).';%generate -1 or 1 randomly by equal probability34
%-----
% phase factor matrix [B] generation
p=[1 -1 1i -1i]; % phase factor possible values
B=randsrc(nos,16,p); % generate nos-point phasefactors
%-----
PAPR=zeros(16,nob);%we calculate PAPR for every OFDM symbols with 16 sets of
phase factors
for j=1:16
% in every cycle of loop we calculate the PAPR for one of the phase
% factors set
OFDM_SLM_symbols=c.*(B(:,j)*ones(1,nob));% multiplying phase factors to all
the blocks of OFDM symbols
Q=ifft(OFDM_SLM_symbols);%ifft transform
clear CPM_SLM_symbols
%-----
Q_abs=abs(Q);%the complex modulus (magnitude)
clear s
Ex2=sum(power(Q_abs,2))/nos;% the average of
PAPR(j,:)=max(power(Q_abs,2))./Ex2;%calculate the PAPR
clear Ex2 s_abs
end
clear c
clear Q
%-----
PAPRdb_BPSK_SLM(i,:)=10*log10(min(PAPR));%calculate the PAPR in db% chose
minimum PAPR and store it in a matrix for plotting them at the end
clear PAPR

```

```

end
%-----
[x,y]=ccdf(PAPRdb_BPSK_SLM(1,:),0.9);%see the ccdffunction
legend('OFDM SLM + CLIPPING','OFDM SLM +CODING','OFDM SLM ONLY ');
semilogy(x,y,'Marker','k','color','g');
hold on;
% gridon %plot command, y axis will be logarithmic
axis([0 13 10^-2 1]);%limit the x and y axis ([xmin xmax ymin ymax]),see help

xlabel('PAPR0 (dB)');%label x axis
ylabel('Prob. (PAPR>PAPR0), ccdf plot');%label y axis

%%%%%%%%%%%%%%%%%%%%%%%%%%%%%%%%%%%%%%%%%%%%%%%%%%%%%%%%

clc
%clear command window
% clear all % clear all variables and matlab figure and

% close all
tic
% Constant value
h=0.3;% COnstant for frequency of phases30
nos=32;%number of subcarrier
nob=10^5;%number of sub blocks
PAPR=zeros(1,nob);%initialize the PAPR matrix to zero
Ex2=zeros(1,nob);
PAPRdb_CPM=zeros(1,nob);% initializing the PAPRdbmatrix
a=randsrc(nob,nos);
nos=16;%No. of subcarriers
nob=10^5;%No. of blocks
PAPRdb_BPSK_SLM=zeros(length(nos),nob);% initializingthe PAPRdb matrix
for i=1:length(nos)
%source bit generation
c=2.*(randi([0,1],nob,nos))-1;
c=c.';
%c=(randsrc(nob,nos(i))).';%generate -1 or 1randomly by equal probabelity
%-----
% phase factor matrix [B] generation
p=[1 -1 1i -1i]; % phase factor possible values
B=randsrc(nos,16,p); % generate nos-point phasefactors
%-----
PAPR=zeros(16,nob);%we calculate PAPR for everyOFDM symbols with 16 sets of
phase factors
for j=1:16
% in every cycle of loop we calculate the PAPRfor one of the phase
% factors set
OFDM_SLM_symbols=c.*(B(:,j)*ones(1,nob));%multiplying phase factors to all
the blocks of OFDM symbols
Q=ifft(OFDM_SLM_symbols);%ifft transform
clear CPM_SLM_symbols
%-----
Q_abs=abs(Q);%the complex modulus (magnitude)31
clear s
Ex2=sum(power(Q_abs,2))/nos;% the avrage of

```

```

PAPR(j,:) = max(power(Q_abs, 2)) ./ Ex2; %calculate the PAPR
clear Ex2 s_abs
end
clear c
clear Q
%-----
PAPRdb_BPSK_SLM(i,:) = 10*log10(min(PAPR)); %calculate the PAPR in db% chose
minimum PAPR and store it in a matrix for plotting them at the end
clear PAPR
end

%-----
[x,y] = ccdf(PAPRdb_BPSK_SLM(1,:), 0.9); %see the ccdf function
semilogy(x,y, 'Marker', 's', 'color', 'r');
hold on;
% grid on %plot command, y axis will be logarithmic
axis([0 13 10^-3 1]); %limit the x and y axis ([xmin xmax ymin ymax]), see help
xlabel('PAPR0 (dB)'); %label x axis
ylabel('Prob. (PAPR > PAPR0), ccdf plot'); %label y axis
legend('OFDM_BPSK', 'OFDM_CPM', 'OFDM-BPSK without SLM', 'OFDM-BPSK-SLM');
hold on;

```