



**INTEGRATION OF ELECTRIC VEHICLES INTO
THE ELECTRICAL GRIDS**

**2021
MASTER THESIS
ELECTRICAL&ELECTRONICS ENGINEERING**

WESAM ANIS MOHAMED ELMASUDI

Assist.Prof.Dr. Hüseyin ALTINKAYA

**INTEGRATION OF ELECTRIC VEHICLES INTO THE ELECTRICAL
GRIDS**

Wesam Anis Mohamed ELMASUDI

T.C.

Karabuk University

Institute of Graduate Programs

Department of Electrical&Electronics Engineering

Prepared as

Master Thesis

Assist.Prof.Dr. Hüseyin ALTINKAYA

KARABUK

June 2021

I certify that in my opinion the thesis submitted by Wesam Anis Mohamed ELMASUDI titled “INTEGRATION OF ELECTRIC VEHICLES INTO THE ELECTRICAL GRIDS” is fully adequate in scope and in quality as a thesis for the degree of Master of Science.

Assist.Prof.Dr. Hüseyin ALTINKAYA
Thesis Advisor, Department of Electrical&Electronics Engineering

This thesis is accepted by the examining committee with a unanimous vote in the Department of Electrical&Electronics Engineering as a Master of Science thesis. June 29, 2021

<u>Examining Committee Members (Institutions)</u>	<u>Signature</u>
Chairman : Assist.Prof.Dr. Harun ÖZBAY (BANU)
Member : Assist.Prof.Dr. Hüseyin ALTINKAYA (KBU)
Member : Assist.Prof.Dr. Mustafa YILMAZ (KBU)

The degree of Master of Science by the thesis submitted is approved by the Administrative Board of the Institute of Graduate Programs, Karabuk University.

Prof. Dr. Hasan SOLMAZ
Director of the Institute of Graduate Programs



“I declare that all the information within this thesis has been gathered and presented in accordance with academic regulations and ethical principles and I have according to the requirements of these regulations and principles cited all those which do not originate in this work as well.”

Wesam Anis Mohamed ELMASUDI

ABSTRACT

M. Sc. Thesis

INTEGRATION OF ELECTRIC VEHICLES INTO THE ELECTRICAL GRIDS

Wesam Anis Mohamed ELMASUDI

Karabük University

Institute of Graduate Programs

The Department of Electrical and Electronics Engineering

Thesis Advisor:

Assist. Prof. Dr. Hüseyin ALTINKAYA

June 2021, 68 pages

The share of vehicles in carbon emissions around the world is very high. In order to reduce pollution and global warming in the world, it is of great importance to increase the share of renewable energy in meeting energy needs, and to increase the number of electric vehicles in transportation. It is known that the number of electric vehicles will increase dramatically in the next few decades. In this thesis, the effects of electric vehicles on the electricity grid have been evaluated. This evaluation is based on the parameters of the TOGG brand electrical vehicle for the distribution network of Karabük University Demir-Çelik campus. Within the scope of this study, simulations and analyzes were made using ETAP Electrical Power System Analysis software in order to examine the effects of electric vehicle charging systems on the grid. According to the scenarios designed for the years 2025, 2030 and 2040, how many and which type of electric vehicle charging stations can be connected to the network within the campus and how these charging stations will affect the network have been examined.

It has been predicted how much additional load the use of electric vehicles and the increase in the university population will bring to the existing transformers and whether additional investments will be needed in the following years.

Key Words : Electric vehicles, Distribution networks

Science Code : 90513, 90515



ÖZET

Yüksek Lisans Tezi

ELEKTİKLİ ARAÇLARIN ELEKTRİK ŞEBEKELERİNE ENTEGRASYONU

Wesam Anis Mohamed ELMASUDI

Karabük Üniversitesi

Lisansüstü Eğitim Enstitüsü

Elektrik-Elektronik Mühendisliği Anabilim Dalı

Tez Danışmanı:

Dr. Öğr. Üyesi Hüseyin ALTINKAYA

Haziran 2021, 68 sayfa

Dünyada karbon emisyonunda araçların payı çok yüksektir. Dünyamızda kirliliğin ve küresel ısınmanın azaltılması için yenilenebilir enerjinin, enerji ihtiyacının karşılanmasındaki payının artırılması gibi ulaşımda elektrikli araçların oranının artırılması büyük önem taşımaktadır. Önümüzdeki birkaç on yılda elektrikli araçların sayısının önemli ölçüde artacağı bilinmektedir. Bu tezde elektrikli araçların (EA) elektrik şebekesi üzerine etkileri değerlendirilmiştir. Bu değerlendirme Karabük Üniversitesi Demir-Çelik kampüsü dağıtım şebekesi için TOGG marka elektrikli aracın parametreleri baz alınarak yapılmıştır. Çalışma kapsamında elektrikli araç şarj sistemlerinin şebekeye olan etkilerinin incelenebilmesi için ETAP Electrical Power System Analysis yazılımı kullanılarak simülasyonlar ve analizler yapılmıştır. 2025, 2030 ve 2040 yılları için kurgulanan senaryolara göre kampüs içerisinde şebekeye kaç adet ve hangi tip elektrikli araç şarj istasyonu bağlanabileceği ve bu şarj istasyonlarının şebekeyi nasıl etkileyeceği incelenmiştir. İlerleyen yıllarda elektrikli araç kullanımının

ve üniversite popülasyonunun artmasının mevcut taraforara ne kadar ek yük getireceđi ve ilave yatırımlara gerek olup olmayacağı öngörölmeye çalışılmıştır.

Anahtar Kelimeler : Elektrikli araçlar, Dağıtım şebekeleri

Bilim Kodu : 90513, 90515



ACKNOWLEDGMENT

Firstly, I would like to express my gratitude and appreciation to Assist. Prof. Dr. Hüseyin ALTINKAYA, a member of the faculty at the Department of Electrical and Electronic Engineering at Karabük University, who provided his full interest and support right from planning to implementation. His knowledge, experience, guidance and assistance helped me to cope with the requirements of this study based on scientific research.

I am also very grateful to the members of the Electrical and Electronic Engineering department, who provided guidance during the completion of this thesis.

I also want to thank my wife, children, family, and all my close friends. Finally, I would like to dedicate this thesis to my mom and dad.

CONTENTS

	<u>Page</u>
APPROVAL.....	ii
ABSTRACT.....	iv
ÖZET.....	vi
ACKNOWLEDGMENT.....	viii
CONTENTS.....	ix
LIST OF FIGURES	xi
LIST OF TABLES	xiii
CHAPTER 1	1
INTRODUCTION	1
CHAPTER 2	5
LITERATURE REVIEW.....	5
CHAPTER 3	10
ELECTRIC VEHICLES	10
3.1. TYPE OF ELECTRIC VEHICLES (EVs).....	12
3.1.1. Battery Electric Vehicles (BEVs).....	12
3.1.2. Plug-in Hybrid Electric Vehicles (PHEVs).....	13
3.1.3. Hybrid Electric Vehicles (HEVs).....	14
3.2. ELECTRIC VEHICLE COMPONENTS.....	15
3.2.1. Electric Motor.....	15
3.2.2. Controller.....	16
3.2.3. Rechargeable Battery.....	17
3.2.4. Battery Charger.....	18
3.2.5. Inverter.....	19
3.3. ELECTRIC VEHICLE CHARGING STATIONS	19
3.3.1. AC Level 1 Charging Station	23
3.3.2. AC Level 2 Charging Station	23

	<u>Page</u>
3.3.3 DC Level 3 Charging Station	23
3.4. TOGG-GERSAN CHARGING STATIONS	23
3.4.1. Normal type (Without Payment System) AC Charging Station.....	24
3.4.2. Smart Type (with payment system) AC Charging Station	25
3.4.3. DC Type Charging Station	26
 CHAPTER 4	 28
ELECTRIC NETWORK MODELING AND CASE STUDY	28
4.1. MV ELECTRICITY NETWORK OF KARABUK UNIVERSITY DEMİR ÇELİK CAMPUS.....	 29
4.2. LV ELECTRICITY NETWORK OF KARABÜK UNIVERSITY DEMİR ÇELİK CAMPUS.....	 34
4.3. EV CHARGING STATION SCENARIOS	46
4.3.1. 2025 Charging Station Scenario	47
4.3.2. 2030 Charging Station Scenario	52
4.3.3. 2040 Charging Station Scenario	55
 CHAPTER 5	 58
CONCLUSION AND SUGGESTIONS	58
 REFERENCES.....	 61
RESUME	68

LIST OF FIGURES

	<u>Page</u>
Figure 1.1.Global energy-related CO2 emissions by sector (Mar 2021).	1
Figure 1.2.Electric vehicle stock scenario in the world, 2018-20.	2
Figure 1.3.Estimates of the total number of EV in Turkey in 2030.	3
Figure 3.1.Bock diagram of EV.	11
Figure 3.2.Architecture of BEV	13
Figure 3.3.Architecture of PHEV.....	14
Figure 3.4.Architecture of HEV.....	14
Figure 3.5.Charging units and station setup.....	20
Figure 3.6.Dependent and independent charging stations	22
Figure 3.7.AC charging station.	25
Figure 3.8.AC smart charging station.	25
Figure 3.8.DC charging station.	26
Figure 4.1.TEDAS MV UNI-1 and UNI-2 feeders.....	30
Figure 4.2.University entrance UNI-1 and UNI-2 feeders.....	31
Figure 4.3.TR2 MV CB and Protection Cubicles	31
Figure 4.4.TR8 MV CB and protection cubicles.	32
Figure 4.5.TR5 MV CB and Protection Cubicles	33
Figure 4.6.TR3 LV Single Line Diagram	34
Figure 4.7.The power graph taken from the Rectorate building in January 2021.	35
Figure 4.8.The power graph taken from the Rectorate building in May 2021.....	36
Figure 4.9.Power graph taken from Rectorate building in 12 February 2021.	36
Figure 4.10.The power graph of the Faculty of Medicine building taken in March 2021.	37
Figure 4.11.The power graph of the Faculty of Medicine building taken in April 2021.	37
Figure 4.12.The power graph of the Faculty of Medicine building, taken in May 31, 2021.....	38
Figure 4.13.The power graph of the FEAS building taken in January 2021.	38

	<u>Page</u>
Figure 4.14.The power graph of the FEAS building taken in April 2021	39
Figure 4.15.The power graph of the FEAS building taken in June 12, 2021	39
Figure 4.16.The SES (solar energy) graph of FEAS building taken in June,12 2021.	40
Figure 4.17.Power graph of Social Life Center building taken in February 2021.....	40
Figure 4.18.The power graph of the Social Life Center building taken in may 2021.	41
Figure 4.19.The power graph of the Social Life Center building taken in April 16, 2021.....	41
Figure 4.20.The power graph of the Faculty of Theology building taken in January 2021.....	42
Figure 4.21.The power graph of the Faculty of Theology taken in May 2021.....	42
Figure 4.22.The power graph of the Faculty of Theology building taken in April 20, 2021.....	43
Figure 4.23.Student Affairs building power graph taken in March 2021.	43
Figure 4.24.Student Affairs building power graph taken in May 2021.	44
Figure 4.25.The power graph of the Student Affairs building taken in January 30, 2021.	44
Figure 4.26.The power graph of the Faculty of Engineering building taken in January 2021.....	45
Figure 4.27.The power graph of the Faculty of Engineering building taken in May 2021.....	45
Figure 4.28.The power graph taken from the Faculty of Engineering in February 25, 2021.....	46
Figure 4.29. ETAP single line diagram of the MV network.....	50
Figure 4.30. ETAP single line diagram of 2025 scenario.....	51
Figure 4.31. ETAP single line diagram of 2030 scenario.....	54
Figure 4.32. ETAP single line diagram of 2040 scenario.....	57

LIST OF TABLES

	<u>Page</u>
Table 3.1. The technical specifications of the charging stations.....	26
Table 3.2. The standart values of the charging stations.	27
Table 4.1.Transformers, their power and the fields they feed.....	29
Table 4.2.of solar energy panels and their power.	30
Table 4.3.Transformers to which parking areas and charging stations will be connected.....	35
Table 4.4.Estimation of the number of personnel and vehicles by years.....	47
Table 4.5. Number of EVs in parking lots according to 2025 scenario.	48
Table 4.6. Number of EV Charging Stations in parking lots according to 2025 scenario.	48
Table 4.7. The additional load of EV Charging Stations according to the 2025 scenario	49
Table 4.8. Number of EVs in parking lots according to 2030 scenario.	52
Table 4.9. Number of EV Charging Stations in car parks according to 2030 scenario	52
Table 4.10. The additional load to be brought by EV Charging Stations according to the 2030 scenario.....	53
Table 4.11. Number of EVs in parking lots according to 2040 scenario.	55
Table 4.12. Number of EV charging stations in parking lots according to 2040 scenario	55
Table 4.13. The additional load of EV Charging Stations according to the 2040 scenario	56

CHAPTER 1

INTRODUCTION

With 23% share in carbon dioxide emissions in the world, transportation has taken the second place [1]. Land vehicles constitute most of this 23%. In order to reduce pollution, global warming, CO₂ and greenhouse gas emissions in the world, increasing the share of renewable energy in meeting energy needs, as well as increasing the share of electric vehicles in transportation is of great importance. In Figure 1.1, the share of sectors in CO₂ emissions as of March 2021 has been given.

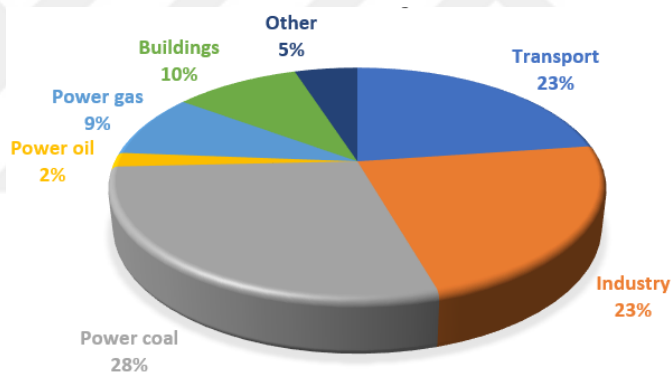

Figure 1.1. Global energy-related CO₂ emissions by sector (Mar 2021) [1].

The use of renewable energy sources has clinched an important place in the energy policies of countries. Electric vehicles have been seen as an alternative to fuel oil vehicles in the automobile sector since the very first day. However, due to the difficulty in electrical energy storage, electric vehicle technology has lagged behind fuel oil vehicle technology. However, thanks to the developments in the field of batteries and power electronics, electric vehicles have managed to become visible in the market for the last 5-10 years.

According to the IEA, with some record-breaking increment in the sales of electric vehicles in 2020, above 10 million electric cars are being driven now on the roads

across the globe. In 2020, the share of electric vehicles in global market have risen by over 4%, previously (in 2019) being at 2.5% level [2]. The IEA estimates that the global number of vehicles could reach up-to 230 million by 2030 if governments take steps in order to meet the global climate change challenges. According to the 2021 Global EV Outlook (Global EV Outlook 2021) report published by the International Energy Agency (IEA), if current policies continue, the number of electric vehicles on a global scale will increase from its current level of 11 million to 145 million in 2030. By doing so, it will increase its market share to 7 percent. The report also stated that if governments take steps to achieve global climate change targets, the number of global electric vehicles is likely to rise to 230 million by 2030 [2]. In the evaluation of the organization, it was stated that if the number of electric vehicles increased to 145 million units, there would be a decrease of 2 million barrels in daily oil demand. Figure 1.2 shows the electric vehicle stock scenario for the years 2018-2030.

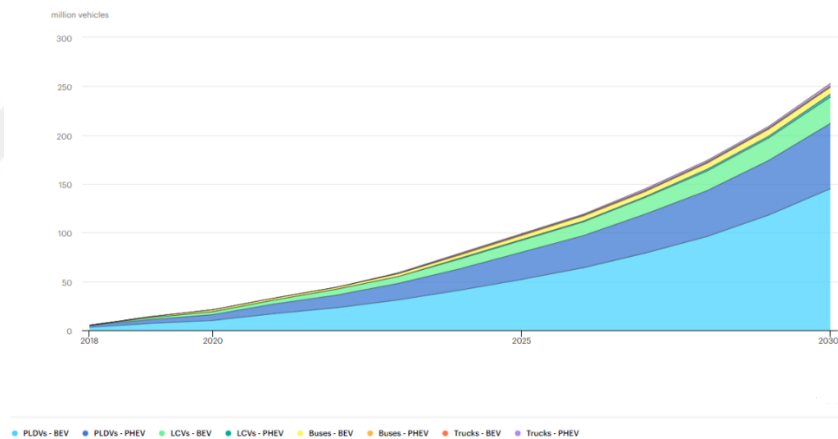

Figure 1.2. Electric vehicle stock scenario in the world, 2018-2030 [3].

According to a report, 154 out of every 1000 people in Turkey own vehicles. It is calculated that by 2030, Turkey's population will exceed 90 million and that 300 out of every 1000 people will own a vehicle. Currently, there are approximately 1800 electric vehicles, 45000 hybrid vehicles and more than 1000 charging stations in Turkey. By 2030, it is predicted that the number of electric vehicles in the country will reach 2.5 million and the number of charging stations will reach 1 million.

During this period, when Turkey's electricity demand is expected to grow by 5 percent, it is estimated that the electricity distribution networks will have the capacity to handle electric vehicles without any problems, provided that the foreseen investments are made [4]. In Figure 1.3, the number of electric vehicles and their share in the stock are estimated according to high and medium growth scenarios.

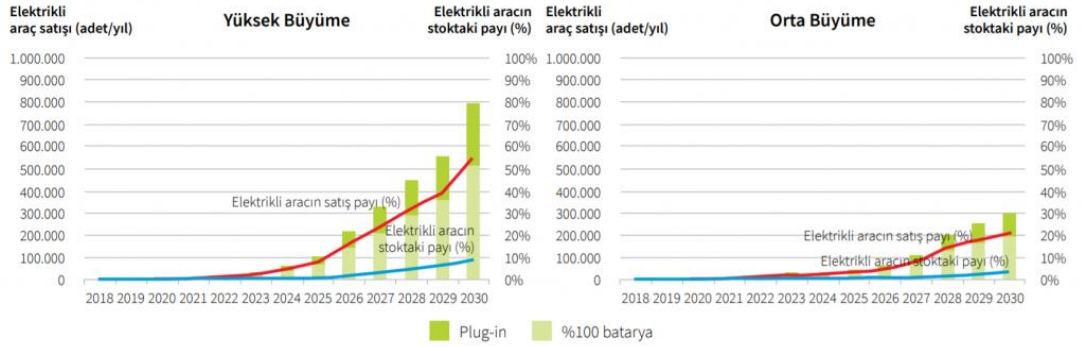

Figure 1.3. Estimates of the total number of electric vehicles in Turkey in 2030.

Both hybrid-chargeable vehicles and electric motor vehicles store energy in their batteries and move with the energy they get from batteries. Although the battery systems on the vehicles may be of different types, systems designed using lithium ion technology are generally used. Both hybrid-chargeable vehicles and electric-powered vehicles must be able to provide the energy they need from a source.

There are different levels of charging systems for electric vehicles. The main difference between the levels is the amount of power transfer because it causes charging systems to be characterized as fast or slow. There are different vehicle charging methods in addition to the vehicle being fed from the mains. Methods such as wireless charging of vehicles, use of regenerative braking systems and battery exchange stations can be given as examples. Charging the batteries of electric vehicles from the grid (G2V), energizing the grid from electric vehicles (V2G), the use of electric vehicles to correct the fluctuations and harmonics in the grid (V4G), charging the electric vehicle batteries from homes (H2V), using electric vehicles as UPS against mains interruption (V2H) and dynamic controlled charging (V1G) conditions appear as usage purposes in studies on electric vehicles.

During the charging of electric vehicles, the energy transferred and the charging time are of great importance. Although there are some main systems used for charging electric vehicles around the world, some companies provide the advantage of faster charging to their users with the charging systems they have specially developed for their own brands. While various systems can be used in different vehicle models, electric vehicle charging stations show differences even between continents and countries. Vehicles must be produced and used within certain standards. The charging equipment and charging stations used for charging the vehicles must be fed through the electricity networks. Integration of electric vehicles and charging systems into the grid is of great importance because electricity networks must meet the power demand required for electric vehicle charging processes and should not affect the electricity quality in the network. For this reason, it is necessary to update the 10-20-year plans in the high voltage (HV), medium voltage and low voltage (LV) parts of the national electricity grid according to this new condition and make additional investments if necessary. It is expected that electric vehicle charging stations will provide the harmonic levels determined by legal limits and will not have a negative impact on the quality of the energy in the grid.

In this thesis, it has been determined that how the electric vehicle charging stations to be connected to the LV distribution network of Karabük University Demir-Çelik campus will affect the network in different scenarios. A summary of the literature has been given in Chapter 2. Chapter 3 provides basic information regarding the definition, types, architectures, components, battery systems and charging stations of Electric Vehicles (EVs). In Chapter 4, simulation and analysis of the effects of charging stations on the electricity distribution network according to different scenarios were conducted accordingly. Finally, conclusions and recommendations were given in Chapter 5.

CHAPTER 2

LITERATURE REVIEW

In a case study performed by Lucian and Dorin, the effects of electric vehicles were analyzed based on the power demand, voltage level and active power losses in terms of different levels of penetration as well as the power demand scenarios. The study was compared with other researches which were performed for the analysis of steady-state condition (without considering the curve of the load), EV models and fewer scenarios. In all scenarios, the voltage level had decreased, however, between the allowed limits [5].

Ali-Mohammad et. al. proposed a new state matrix method (S-matrix) for investigating the operating modes of smart grid including the novel model by utilizing the graph theory and segmentation concepts, thus, developing a completely new comprehensive model taking into consideration all the uncertainties as well as integrating methodologies used in separate elements. Their proposed method was applied to 33-bus test system of IEEE [6].

The paper presented by M. Khalid et. al. in 2019 discussed the charging station structures available at that time which were being used commonly and included structures comprising back-to-back converters (ac/dc/dc), structures with common ac link and multiple dc port and structures having no isolation transformer. In addition, the afore-mentioned structures were sub-divided into inductive charging and conductive charging structures, respectively [7].

In a comprehensive study of Sami et. al. in 2019, Smart Building (SB) interaction was demonstrated using Power EVs (for load shifting of grid), peak trimming, energy storage devices and energy usage reduction on annual basis. Quick charging and discharging, Vehicle-to-Grid interfacing, reliability and battery backup were the main

points analyzed and discussed in their study. In addition, they presented G2V (Grid-to-Vehicle) and V2G (Vehicle-to-Grid) simulation model in order to describe different parameters that affect the grid network. Their case study determined several controller parameters which affect G2V and V2G dynamics of the grid-support stability, grid inter-connected system and its control [8].

Recently conducted studies have shown that electrical vehicle (EVs) being eco-friendly and less emission vehicles have more advantages when compared with other transportation types. The Vehicle-to-Grid (V2G) application is thought to be beneficial both for the the EV owners and as well as for grid operator [9-12]. A comprehensive evaluation and review of Vehicle-to-Grid system has been reported by M. Kumar et. al., thus affirming all the advantages as well as the overheads of the mentioned system in contrast to charging strategies (controlled and uncontrolled) and the charging schedule of electrical vehicles [13].

A battery of vehicle may provide fast regulation through altering its charging rates and discharging rates in the V2G mode. With frequency regulation, V2G system may also provide active power or reactive power support [14]. It plays a more important role for the micro-grid because the consumption and generation are comparatively more volatile, and the unpredictability of distributed demand patterns and the power sources in a micro-grid make it difficult to reach to the demand and supply balance [15]. In the normal and abnormal conditions of operation concerning the power system, the min. frequency restoring time and min. frequency regulation cost along with the battery degradation cost ought to be considered in the system, respectively [16], [17].

In a study conducted by Zheng et al., the practical coordinate charging implementation was promoted and some real-time coordinated problem related to large-scale EVs were considered [18]. In their study, Liu et al., determined that charging the EVs on a larger scale may cause significant impact on the power grid and this was considered to be a promising way in order to decrease the impact by taking advantage of smart grid and exploiting the local power generation [19]. The paper presented by Shokrzadeh et al. demonstrates an algorithm used for utilities in order to specify the optimal scenario for

electric load control of electric vehicles and a dataset of real-world driving data was used to emulate more realistic driving patterns to obtain the simulations [20].

The study performed by Park et al. determined the change of generation capacity and also the change in power generation by using WASP model to obtain the precise results of the analysis performed for finding the effects of effects in the management of EV. WASP model was used to examine the power generation mix as well as the change in installed capacity [21]. There are many studies that have been performed to elucidate the demand response and smart charging effects and the impact of EVs on electricity demand, and the studies conducted by Bahrami et al. [22], Gnann et al. [23], García et al. [24] and Muhammadi [25] have analyzed the effect of EVs on electricity profile and have emphasized on smart charging as well as demand response importance. In a study by Amini et al., the analysis of simultaneous allocation in the parking lots of EVs and distributed renewable resources was performed in power distribution networks [26]. In their study, Lopez et al. reviewed the management of demand-side in some SG operations by considering the V2G and EV load shifting. The study mainly focused on increases in peak load which were caused due to diffusion of EVs and this was suggested to be decreased using V2G support and smart charging [27].

In a study Kim et al., in order to understand EV effects comprehensively using SGs in power sector, it was essential to evaluate the supply specifics as well as the demand sector (including peak load) [28]. Weis et al., in their study, reviewed the controlled EV charging potential to mitigate the operational tasks as well as the costs of capacity expansion in the electric power systems [29]. In their respective studies, Delgado et al. [30], Sorrentino et al. [31], Choma et al. [32] and Croziera et al. [33] have assessed the EVs' potential impact carbon dioxide in accordance with the different generation mixes. They afore-mentioned studies have helped the researchers understand the EVs' impacts better on CO₂ emissions and generation costs. However, they also had limitations in their analyses of impacts at some installed capacity mix, and these studies have not considered the change in the given capacity mix.

In a study by Shaukat et al., the TE sector was explored and the impact of this sector on economy, eco-friendly system and reliability was investigated. The V2G

technology and the challenges related to its implementation were reviewed along with different energy storage technologies being deployed in EVs [34]. In their study, Rahbari et al. proposed a practical solution in order to deal with the challenges regarding integration of renewable energy sources as well as electric vehicles into electric power grid, in addition to considering energy usage inconsistency and generation source intermittency using an adaptive intelligent controller [35].

Shaaban et al. has performed an optimal sizing as well as siting of renewable energy systems by identifying the optimal bus, which is a 33-bus grid, to install the renewable distributed generation. It was carried out to maximize savings by allowing system upgrade and by doing so the costs of energy losses were reduced [36]. In a study performed by Feruzzi et al., a demand side management technique was examined and sensitivity analysis was performed for a micro-grid, thus including a photovoltaic plant [37]. Similarly, Vasirani et al. evaluated the agent-based approach in order to take advantage of EVs being used as storage systems and increasing the profit as well as reliability of wind energy [38]. In a study by Falvo et al., the EV integration into the grid was proposed to require an appropriate control of charging and discharging duration, thus considering the driving needs as well as simultaneous support for power services [39]. In a study performed by Lopez et al., for load shifting purposes, an optimization-based model was utilized in the smart grid environment and the study was conducted on 27-bus distribution grid [40].

Graditi et al. have investigated the economic aspect of the battery energy storage utilization systems to implement the load shifting at consumer side by applying specific electricity tariffs and have stated that techno-economic analyses when integrated with energy systems can be merited [41]. In a similar study by Rahimi-Eichi, not only the battery management system's pros and cons were evaluated but also the opportunities, challenges and needs for integration of renewable energy, EVs and smart grids by focusing on power lifetime, delivery, cost, SoC and reliability [42]. In a study, Silvestre et al. evaluated the load consumption profile and initial SoC of EVs in order to minimize the energy costs and power losses using smart charging [43]. In another study, it was reported that the majority of PEVs can utilize the Li-ion batteries due to the environmental advantages, longer life span, light weight and high

energy density [44]. In their study, Omar et al. showed that lithium-ion batteries' energy efficiency can be more superior to other rechargeable batteries based on tests including dynamic discharging performance [45]. Furthermore, they also showed that lithium-ion batteries' performance can be highly dependent on depth of discharge as well as the temperature [46].

In a study conducted by Kim et al., it was reported that the investments and innovations are growing at a rapid rate and EVs will be able to feed the energy back to the grid using V2G technology and this will in turn lead to a completely new regulatory discussion eventually [47]. Das et al. in their paper proposed a SCS-Algorithm (Smart Charging Scheduling Algorithm) used for charging solution via coordinating multiple PHEVs in that respective smart grid system. The utilities have recently become anxious regarding voltage stresses, overloads in distribution systems and smart grid performance degradations [48]. In their paper, Salehpur et al. proposed new mechanism which was based on agreements between the smart micro-grid and owner of electric vehicles and this mechanism was to provide energy of the system during the operating day. Their model enabled plug-in electric vehicles that were parked in the official parking which was to be integrated to smart micro-grid in order to earn revenue [49].

CHAPTER 3

ELECTRIC VEHICLES

Electric vehicles can be described as vehicles with batteries on them which convert the energy they store into kinetic energy through electric motors. An electric car is a car that is driven using one or more electric motors which use the electricity stored in batteries and other energy storage devices. Electric motors give instant torque, providing powerful and balanced acceleration.

Electric drive motor of above-mentioned vehicles can also be called electric traction. Therefore, such vehicles sometimes are called electric traction vehicles as well [50]. Generally, the electric cars have no exhaust fume emission. They have better driving characteristics, better performance and do not generate noise when compared with vehicles comprising an internal combustion engine with same power. Hence, their advantages are countless. However, such vehicles are currently commonly used in some public transportation such as trams, railways etc. as well as in personal and autonomous transport systems (transporting smaller loads) due to limited control thus resulting from the technical obstacles which are related to battery capacity problem and electricity supply. Recently, a considerable work has been carried out on the gradual introduction and development of electric passenger cars. Therefore, it is considered that these vehicles will have a control over an extensive part of the automotive market in the near future. Unconventional vehicles, for example, rail floating vehicles which are powered by linear electric motors, will be considered only in the initial stages of the application [51].

An electric vehicle has an electrical system which is a closed circuit consisting of either a rechargeable battery or an independent power source. In case of a hybrid vehicle, power source may be combined with some internal combustion engine converting mechanical energy into electricity and accumulating them in the battery. Nowadays,

we can supply electricity to cars using regenerative braking and the part of kinetic energy to be lost as heat can be stored in another energy form [52].

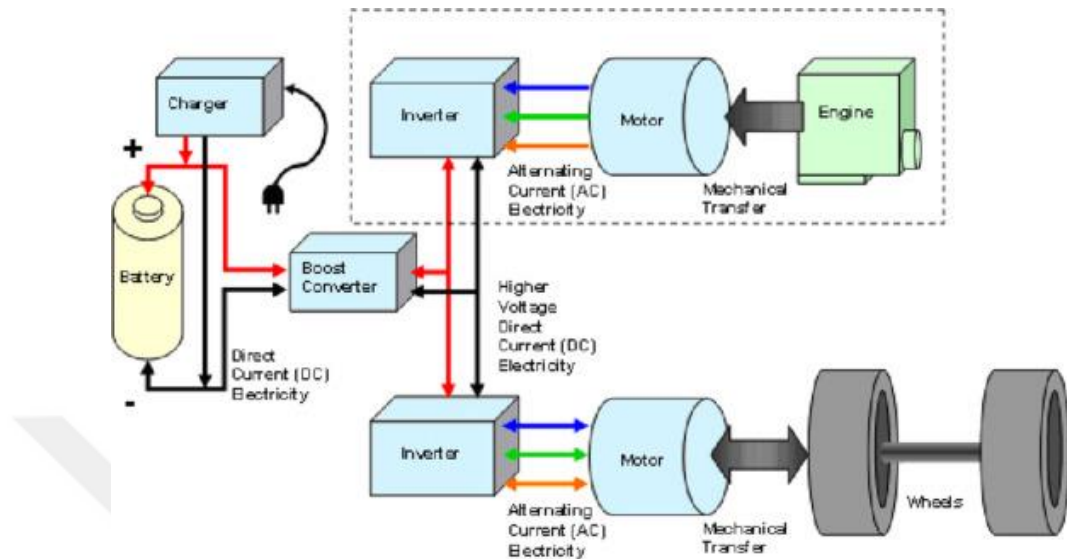

Figure 3.1. Block diagram of EV [53].

In case of an electric vehicle powered with battery source with no internal combustion engine the circuit thus operating is based on proper functioning of a rechargeable battery. The system needs to be charged using a connection to electricity grid. The rechargeable battery is charged by chargers that convert mains AC voltage into battery DC voltage. Thus, this system may be charged using home connection for 6 to 8 hours on average. The modern cars being used these days have 12V batteries. The battery capacity can be measured in ampere hours. For instance, a 56ah battery can deliver or 2 amps for a duration of 28 hours or 1 amp current for 56 hours. When the battery voltage drops, the current flowing is less, and eventually, the voltage and current values are insufficient for the components to function properly. The rechargeable battery is known to be the only energy source which supplies direct current to amplifier, thus increasing the obtained voltage and current to a greater extent. Passing through the amplifier, current converted into AC (alternative current) in the inverter is fed to electric motors; the most essential components of any electric vehicle. The electric motors carry out the task of conversion of electrical energy into mechanical energy by using the electromagnetic induction principle, and the produced mechanical energy is transmitted to rotating wheels via transmission. The other important part of

the system is the controller which is responsible for carrying out the control of electric motor. This can be rendered as a functional unit of the electric motor [52].

3.1. TYPE OF ELECTRIC VEHICLES (EVs)

3.1.1. Battery Electric Vehicles (BEVs)

The Battery Electric Vehicle (BEV) is also known as All-Electric Vehicle (AEV). It runs entirely on electric drive train and a battery. BEVs are quite often called electric vehicles. BEVs are run entirely using batteries which have a full-electric drive train unlike PHEVs and HEVs. As a matter of fact, it is one of the pros of battery electric vehicles that ought to be considered. In a battery electric vehicle, the number of moving parts is very few hence it requires very little maintenance. As no tune-ups or oil changes are required, the savings from not undergoing such maintenance expenses can make a huge difference over the lifetime usage of the vehicle. The battery electric vehicles solely rely on the amount of electricity stored in their respective batteries. Therefore, such vehicles need to be recharged quickly as compared to plug-in hybrid models.

Battery Electric Vehicles do not have any combustion engine and its electric motor is supplied through a battery propelling the wheels. Furthermore, BEV's battery is charged via power grid by using plug-in electric cables [54].

The architectural structures of this type of electric vehicles are simple when compared to other vehicle types. The most important parts of such cars are the batteries which store the energy by converting AC or DC electrical energy into a load. Since there is no energy production mechanism in these vehicles, the batteries are filled with external load transfer. There are fast charging stations with different power transfer capacities developed for charging vehicle batteries, and these vehicles have power inputs which can be connected to the grid [55].

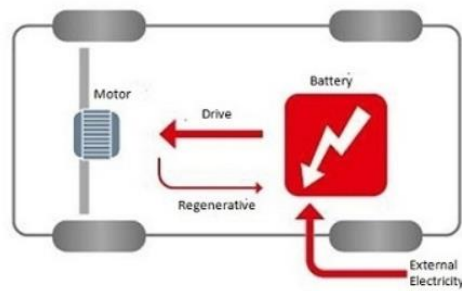

Figure 3.2. Architecture of BEV [56].

For the electric motor to operate, the power is converted from DC to AC. There is an accelerator pedal that sends the signal to the controller which in turn adjusts the speed of the vehicle by altering the AC power's frequency from inverter to motor. The wheels are connected to the motor and are rotated by the center-of-gravity (COG) phenomenon. When the brakes are applied and EV decelerates, the motor functions as an alternator and power is produced, which is fed back to the battery.

3.1.2. Plug-in Hybrid Electric Vehicles (PHEVs)

Externally rechargeable hybrid electric vehicles have an engine that uses fossil fuels and also an electric motor. The dynamic systems on these vehicles can be driven by the power of the batteries of electric motors, and they can also use the energy produced with the help of fossil fuels for movement. In this type of vehicles, the battery unit can be charged externally. Charging can be carried out via grid systems with external charging equipment or via electric vehicle charging stations.

When compared, the biggest difference between a plug-in hybrid electric vehicle and a regular hybrid vehicle is that there are larger batteries in the plug-ins which can be plugged-in in order to charge the batteries. They also have comparatively larger electric motors, because more work has to be done by PHEVs. As plug-in electric cars carry larger vehicle batteries, they are able to propel the car for particular period of time without requiring the assistance of combustion engine [56].

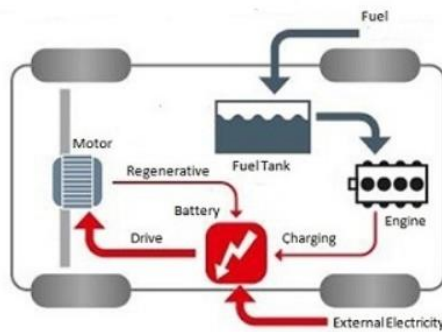

Figure 3.3. Architecture of PHEV [56].

3.1.3. Hybrid Electric Vehicles (HEVs)

Hybrid electric vehicles are the combination of an electric propulsion system and a conventional internal combustion engine. In this type, the internal combustion engine performs most of the task, whereas the electric motor helps the engine and its main purpose is to increment of fuel economy. Hybrids have no ability of plugging in and recharging from the grid. Therefore, they use regenerative braking systems and internal combustion engines to recharge their respective propulsion vehicle batteries. Most of the hybrids cannot propel the car solely on battery power, and need a combustion engine while they are moving. HEVs do not have external charging points, hence, the small battery needs to be recharged with the help of gasoline engine during breaking action [4,5].

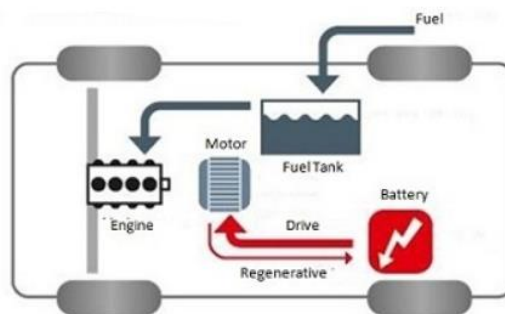

Figure 3.4. Architecture of HEV [56].

3.2. ELECTRIC VEHICLE COMPONENTS

Basic elements in an electric vehicle are electric drive batteries, electric motor and motor controller, while the other parts include: contactor, fuse, switch, analogue-to-digital pedal signal converter, DC voltage converter, installed vehicle equipments

which function at 12V voltage level (lights, wipers, turn signals, audible signal radio etc.), some measuring instruments such as battery capacity indicator, power, speed, voltage, current etc., and battery charger [57].

There are some other parts which are a must for electric vehicle. For instance, drive voltage cables, cable lugs, 12 V auxiliary voltage cables, cable connections and 12 V auxiliary voltage batteries. A battery can be rendered as a component which determines the characteristics of an electric vehicle along with its price, availability and its autonomy. Battery performance is determined by two factors which are as follows: Power (acceleration) and Energy (distance traveled). An electrically powered vehicle contains other parts which are: emergency stop switch, key switch, resistor for inhibiting discharge of electric battery, inertial switch, heaters for interior heating of vehicle, battery control system, control system, electric pump for power steering system, vacuum pump (for braking system) and hydraulic pump if needed [57].

3.2.1. Electric Motor

Certainly, the greatest distinction among classic and electric vehicles is the motor. Conventional vehicles use petroleum or diesel motors, whereas an electric vehicle uses an electric engine. The main part of any electric vehicle is the electric motor which is an electric machine that is responsible for the conversion of electrical energy into mechanical energy utilizing the electromagnetic induction principle. Electric motors have a lot easier concept in construction as compared to internal combustion engines. Present day internal combustion engines comprise of around 1000 small parts, whereas the electric motor generally comprises of three to five dynamic parts, which makes them substantially more solid and sturdy. The motors have two windings (stator and rotor), one of which is an excitation winding and the other is a working or armature winding. There are also constructions where the excitation winding is replaced by permanent magnets. Such engines require very little or virtually no maintenance because they have no consumable parts. As a rule, the electric motor enables linear and continuous acceleration of vehicles with significantly higher traction characteristics compared to conventional vehicles. On the other hand, electric cars do

not have gearboxes. The elimination of the gearbox significantly reduces the weight of the car, which also leads to significantly lower fuel consumption and on the mechanical side reduces the price of the vehicle on that side [58]. The motors consist of two windings called rotor and stator. One is an excitation winding while the other is armature winding. There are addition constructions where permanent magnets are used instead of excitation winding. Such motors require practically no maintenance since they haven't any consumable parts. Generally, the electric motor allows continuous and linear speed increase in vehicles with comparatively higher traction properties when compared to conventional vehicles. In addition, electric vehicles don't have gearboxes and this essentially mitigates the weight of the vehicle, which in turn prompts lower consumption of fuel and decreases the cost of the vehicle on the mechanical side [59].

There are different types of electric motors which have significant differences in their principle of operation and construction. Depending on the source they use and the type of current that flows, we may distinguish them as follows;

- AC motors,
- DC motors,
- Universal motors [60].

3.2.2. Controller

Considerably, among the most important parts of electric vehicle comes the controller which controls the operational tasks of vehicle system and electric motor and converts the direct current in the batteries into an alternating current through a software installed on a device. The device and its software are mounted in the front, and are operated through a touch screen. The device monitors the condition of the vehicle, coordinates the required actions and responds promptly to changes seen in external driving conditions by sending signals to power unit as well as other installed systems which enable greater stability in driving and also safety for passengers.

The controller uses a processor to control the events when the vehicle is in running mode and the processor monitors accelerator pedal thus using the data to check and control the motor current. Other processors, not included in the module, are used in order to ensure that the appropriate torque is generated in the motor, and also for the operation of some other components. For instance, when the specified processor monitors the battery's condition that whether or not it is full, the regenerative torque is decreased accordingly, and when the sensor detects that the ideal temperature has been exceeded by the processor, the motor current is also decreased [61].

3.2.3. Rechargeable Battery

Batteries, used for energy storage, are the main reason behind slow development of electric vehicles. At the beginning, lead batteries were used in electric vehicles, however due to relatively poor properties of such batteries, lithium batteries emerged in the market. Actually, they are lithium-ion batteries with capacity depending on autonomy of electric vehicle. Lithium-ion batteries are three times smaller and lighter as compared to lead batteries with the same capacity [62].

Some types of such batteries may withstand fast charges and may be charged within twenty minutes or so using a powerful charger. The battery life as well as the characteristics of these batteries depend on the lithium technology type. For example, LiFePO₄ batteries may withstand nearly 3000 charging cycles, in accordance with the warranty of manufacturers. Some battery types may even withstand ultra-fast charges and may be charged within 15 to 30 minutes. Today, the capacity of batteries is nearly sufficient to fulfil the average daily needs of personal vehicles. Considering lead batteries, about 60 kg of batteries would be needed to store 1 kWh electricity. If an approximation is to be made, it would take about 7 kg of batteries for almost 1 kilometer travelled, and for 100 kilometers it would take 700 kg of batteries, taking up to 300 liters of space. The lead-acid batteries cannot withstand rapid charging i.e. less than two hours. The battery life can be expressed in number of cycles (charging and discharging). The lead batteries are intended to be used for the propulsion of electric vehicles and generally last 500-1000 cycles or even five calendar years [63].

The manufacturers all around the world are investing a lot for the ultimate purpose of developing new technologies for electric batteries and have achieved an intensive increase in battery capacity, leading to an increase in vehicle range. The electric vehicles are expected to have autonomy of nearly 350 km on one-time battery charge. The battery life is aimed to increase within 7 to 10 years depending on battery type [64].

The battery needs to be replaced, thus resulting in more and more discarded batteries in nature. Even though there are some laws to be abided by on battery disposal, the ultimate solution is found by manufacturers. The solution is to offer customers the renting option, which means that the recycling of the batteries is to be performed by the manufacturer, not the customer. In the studies conducted so far, it has been shown that the battery being used as an alternative to fuel does not cause problem for the environment.

Today, there are some new techniques being implemented in order to make the rechargeable batteries (150 to 175 Wh/kg), thus bringing a greater shift in the development of batteries to be used for electric vehicles. However, battery manufacturers are planning to produce batteries with higher capacities in the future when compared to the same batteries today. Hence, from 2015 to 2020, the capacities of batteries are expected to be increased from 175 to 240 Wh/kg. Considering the lithium-based batteries, the battery manufacturers seem to have reached a technological limit and it seems that they have no much room for developing them further. However, a quantum leap can also be expected in the development process of such vehicle batteries. The growing interest towards the development of electric vehicle batteries have led the manufacturers to develop various techniques with even greater safety, greater capacity, and to develop newer techniques and materials in order to produce the most suitable rechargeable batteries for EVs [65].

3.2.4. Battery Charger

Battery chargers are one of the most important parts of EVs. They are used in the conversion of AC voltage (Mains) to DC voltage (Battery). The EVs are connected to

either home installation or some other source of electricity through these chargers and the charging time totally depends on them. Weaker chargers may charge an electric car in nearly 8-10 hours, whereas, stronger chargers can do it even faster and charge the EV in approximately 20 minutes. Such chargers may be installed in the vehicle, but not necessarily.

3.2.5. Inverter

Inverter systems on electric vehicles are interfaces that are responsible for driving electric motors. They control the process of drawing the energy needed by the electric motor from the battery and transferring it to the motor according to the driver's usage. In addition, the process of returning the energy generated during the regenerative braking of electric vehicles to the system is carried out via the inverter.

3.3. ELECTRIC VEHICLE CHARGING STATIONS

In this section, some definitions of the terminologies used for electrical charging stations and information regarding the types of charging stations will be given [66].

- **Charge Connector:** It includes the apparatus such as cable, socket etc. which are physically connected to the electric vehicle and provide electricity transmission.
- **Charging Supply Equipment (EVSE):** It is considered as an independently operated and managed part of the charger. Charging equipment energizes only one electric vehicle at a time, and may consist of one or more than one charging connectors of different types.
- **Charging Unit (EV Charger):** It is a physically indivisible infrastructure element that provides electrical energy for charging electric vehicles. Charge units may have one or more than one supply equipment.
- **Charging Station:** It is a system consisting of one or more charging units, which can be managed remotely or locally.

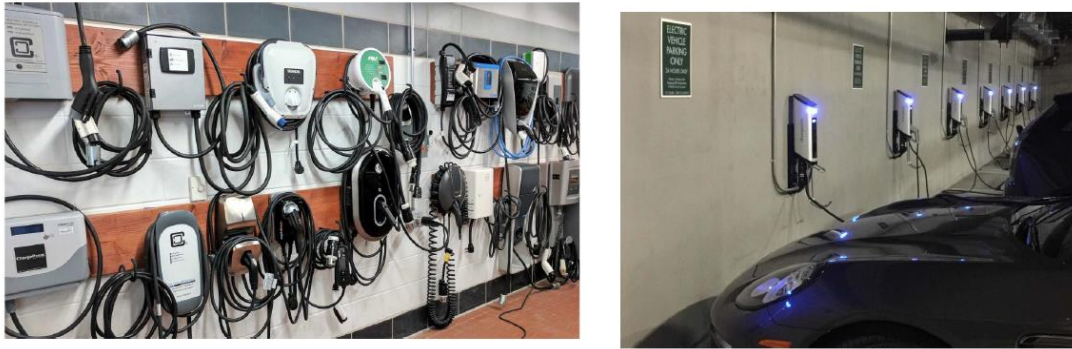

Figure 3.5. Charging units and station setup.

- **Charging Network:** It is a complete infrastructure system managed by the Charging Network Operator, established to charge electric vehicles at multiple points.
- **Charging Network Operator (EMP/MSP – e-Mobility Service Provider)*:** It is the company that provides electric vehicle owners the access to the charging network, and provides charging services and collects payments from vehicle owners for charging operations.
- **Charging Station Operator (CPO/CSO - Charge Point (Station) Operator)*:** It is a company that operates charging stations on-site and provides access to these charging stations to third parties. It receives the payments for the charging transactions that occur at the stations from the Charging Network Operators.
- **Service Point (Location):** These are the points where charging services are provided for electric vehicles with charging stations. A service point can have more than one station. For example; Charging stations at different points in a large parking lot.
- **Location Host:** They are the legal person or entities who are either the owner or the responsible person of the service point where the charging stations are physically installed. The electrical infrastructure needs of the charging stations are met through the electricity subscriptions of the Location Host.
- **Investor/Station Owner:** The person or legal entity who invests on the charging station.

- **Roaming:** This allows vehicle owners to use their charging network memberships provided by one operator at the charging stations of different operators.
- **Private Charging Station:** These are the charging units which individuals use to charge their own vehicles. Electricity transmission is carried out by connecting to the person's own electricity subscription (meter). No payment is taken from the user during the charging process. In terms of use, there is no difference between this and any electrical device in the house.
- **Semi-Public Charging Station:** In non-public areas (apartment/office building, hotel car parks, etc.), it is the type of charging station open for the use of only those with restricted access to the service point. They can be managed centrally. Depending on the application area, the user can be charged during the charging process or free charging can be performed.
- **Public Charging Station:** It is a type of charging station open to third parties, except the station owner, and is situated in public areas (shopping malls, recreational facilities, open parking lots, etc.). It is managed through the charging operator company's central system. Depending on the application area, the user can be charged during the charging process or free charging can be performed.
- **Dependent Charging Station:** Service points are stations that are installed in an area connected to another business/building and whose electrical infrastructure needs are met by the building/business to which they are connected. They are installed in shopping malls, apartments, offices, resting facilities etc. The stations located in the open/closed car parks of the service points are connected stations.
- **Independent Charging Station:** These are the stations that are not installed in an area connected to any other building. The electricity infrastructure is totally independent. Such stations are opened only for the charging stations and are operated by the charging station operator company. These stations are independent stations installed in areas such as highways and street sidewalks etc.



Figure 3.6. Dependent and independent charging stations.

Batteries on electric vehicles need to be charged periodically, either with charging equipment at homes or through charging stations [65]. Different classes and types of charging units can be used for the charging of electric vehicles. Basically, the differences between charging equipment are the supplied current values transferred to the vehicle and the supplied voltage types used for charging (AC or DC supply sources can be used). Electric vehicle charging is generally performed at three different current and voltage levels. These charging levels are AC Level 1, AC level 2 and DC Level, respectively. According to 2017 data obtained from the US Department of Energy, 80% of EV charging stations across the US are of the AC Level 2 type [67].

Electric vehicle charging stations are designed differently based on the countries in which they are used. Electric vehicle charging stations, which are mainly grouped as North America and Europe, are required to comply with different protocols. The North American region or the regions using electric vehicles in North American standards have to comply with SAE (Standard of Automotive Engineers), the standard suitable for electric vehicles in this region. In European countries or countries where electric vehicles are used in European standards, the standard that electric vehicle charging stations must comply with is IEC (The International Electro-technical Commission) [68].

While there are similarities in the standards accepted by different continents, regions and countries, the standards of charging stations may also vary. Since this thesis is

based on TOGG electric vehicles and their charging units, the values of the charging units will be given accordingly.

3.3.1. AC Level 1 Charging Station

Type 1 charging equipment is known as stationless charging equipment, which is usually supplied along with vehicles because these chargers have low power transfer capacities, and are often known as slow chargers.

3.3.2. AC Level 2 Charging Station

Level 2 EV charging units are known as station type. They are charging equipment with high power transfer capacities designed to meet the faster charging requirements of vehicles.

3.3.3 DC Level 3 Charging Station

It is the most advanced charging method used in the charging of electric vehicles. Level 3 charging equipment serves as a station. While vehicles that can be charged with DC can benefit from these charging equipment, vehicles designed to be charged with AC cannot be charged through these stations.

3.4. TOGG-GERSAN CHARGING STATIONS

While researches are being conducted on electric cars in many countries of the world, a valuable step has been taken in this regard in Turkey as well and domestic cars have been developed. The domestic electric vehicle in Turkey will be produced in 5 different models by Automobile Enterprise Group (TOGG) which is carrying out extensive research work. The C-SUV will be presented first, then the C-Sedan model, C-Hatchback, B-SUV and C-MPV models will be presented, respectively [69].

According to the information obtained from TOGG, the vehicle, which has its own unique lines, will fully meet the standards of EuroNCAP, one of the world's leading automobile safety testing organizations. Authorities expect the domestic car to leave EuroNCAP tests with 5 stars in 2022. Apart from that, some of the highlights of the car are as follows:

- The domestic car will be constantly connected to the internet.
- It will enable advanced autonomous driving.
- This will be able to charge up to 80% in less than 30 minutes.
- It will leave a clean world for future generations, thanks to its zero emission property.
- It will appeal to the global market with its advanced technological features.

TOGG offers two different engine options. In the first option, there is an engine that can produce 200 horsepower and the vehicle accelerates from 0 to 100 km/h in 7.6 seconds. In the second option, there are 2 engines and with the engine that can produce 400 horsepower, the vehicle accelerates from 0 to 100 km/h in 4.8 seconds. In short, both models will be much faster than their fossil fuel counterparts currently on the road in Turkey. The maximum speed that the domestic car can reach will be fixed at 180 km/h for safety reasons.

There are two different options in the battery of the TOGG car, as in the engine power. In the first option, the vehicle will be able to travel 300 kilometers on a single charge. In the second option, the range of the domestic car will be up to 500 kilometers. At the same time, thanks to the regenerative braking technology in the vehicle, the battery can be charged with energy recovery as the drivers apply the brakes. Less than 30 minutes will be enough for the battery of TOGG cars to reach 80% charge [69,70].

3.4.1. Normal type (Without Payment System) AC Charging Station

The normal type (without payment system) AC charging station has charging currents ranging from single-phase (1P) 16A (3.7kW) to three-phase (3P) 63A (44kW) and can

charge at varying times depending on the capacity of the vehicle. The station includes standard features and protection functions that are compatible with all vehicles as basic requirements. The station has 1 Mod-3 Type-2 charging socket in accordance with IEC 62196 standards. Optionally, up to 4 sockets can be placed to charge 4 vehicles at the same time. Mod-1/2 CEE or “Schuko” sockets can also be used as sockets [71].



Figure 3.7. AC charging station [71].

3.4.2. Smart Type (with payment system) AC Charging Station

The smart type (with payment system) AC charging station has charging currents from single-phase (1P) 16A (3.7kW) to three-phase (3P) 63A (44kW) and can charge in times that vary according to the capacity of the vehicle. The station includes standard features and protection functions compatible with all vehicles as basic requirements. The station includes functions such as kWh energy meter, RFID card reader, 7" touch screen, communication and internal software. The touch screen includes internal software and visual animations that guide the user. The station has 1 Mod-3 Type-2 charging socket in accordance with IEC 62196 standards. Optionally, up to 4 sockets can be placed to charge 4 vehicles at the same time. Mod-1/2 CEE or “Schuko” sockets can also be used as sockets [71].



Figure 3.8. AC smart charging station [71].

3.4.3. DC Type Charging Station

The DC (Fast) charging station has a charging power ranging from 15kW to 350kW and more, and can charge at varying times depending on the capacity of the vehicle. The station can have 1 Plug and Mod-3 and Type-2 charging socket in CCS/Chademo standards. Optionally, it includes a plug/socket for simultaneous AC or DC charging of the vehicle.



Figure 3.9. DC charging station [71].

The units are designed in IEC 61851 standards. IEC 62196-1, IEC 62196-2, IEC 61851-1: 2010, IEC 61851-21: 2002, IEC 61851-22: 2001 ISO 9001 - ISO 14001 - OHSAS 18001 - AS9100 IEC / TS EN 61851 and CE standards are complied with. The following table gives the technical specifications of the charging stations.

Table 3.1. The technical specifications of the charging stations [71].

GCS Teknik Özellikleri	GSC Technical Properties		
Akım	Rated Current	16/32/63A	16/32/63A
Gerilim	Rated Voltage	220/380V	220/380V
Faz	Phase	3	3
Frekans	Frequency	50Hz AC	50Hz AC
Şarj Modu	Charging Mode	Mod-1/2/3/4	Mode-1/2/3/4
Priz Tipi	Socket Type	Tip-1/2/Schuko/Combo	Type-1/2/Schuko/Combo
IP Koruma	IP Protection	IP54/55	IP54/55
Koruma	Protection	Aşırı Akım/Kısa Devre/Kaçak Akım	Over Current/Short Circuit/Earth Leakage
Ekran	Screen	TFT 7" Renkli Dokunmatik Ekran	TFT 7" Colorful Touch Screen
Kart Okuyucu	Card Reader	RFID Kart Okuyucu	RFID Card Reader
Haberleşme	Communication	Ethernet TCP/IP	Ethernet TCP/IP
Standart	Standard	TS EN / IEC 62196 & 61851 & 60529	TS EN / IEC 62196 & 61851 & 60529

In the table below, the standard values (number of phases, current, power values) of the charging stations are given.

Table 3.2. The standart values of the charging stations.

Phase	Current (A)	Power (kW)
1	16	3.7
1	32	7.4
3	16	11
3	32	22
3	63	44
DC	-	25-50



CHAPTER 4

ELECTRIC NETWORK MODELING AND CASE STUDY

In this chapter, after analyzing the existing electricity grid for Karabük University Demir Çelik (Central) campus, three different case studies were conducted for the years 2025, 2030 and 2040 according to three different scenarios. The number of EVs that can be found on campus in 2025, 2030 and 2040, and in accordance with this number, the necessary number of EV charging station scenarios were studied and the effects of charging stations on the grid were to be estimated.

Electric vehicle charging stations can be of different types according to the grid voltage value, electricity frequencies, power transmission capacities, power transmission duration, types of vehicles they charge and vehicle brands of the countries they are used in. Even the same vehicle charging stations may vary according to the vehicle standards being used in that particular country. However, most EVs and EV charging stations show the same or similar properties in terms of electrical characteristics (power, charging duration, etc.). In this study, TOGG brand EVs and GERSAN charging stations were taken into consideration. ETAP Electrical Power System Analysis Software was used for network modeling and simulations.

There are different companies that design and implement electric vehicle charging systems in Turkey. In general, there is a classification according to the power of electric vehicles. Examining the products of the brands in this respect, it is seen that the energy power levels of the products are 3.7kW, 7.4kW, 11kW, 22kW and 44kW, respectively. Within the scope of the thesis, 22 kW, 3-phase and Smart type charging unit model of Gersan Company will be used as a model.

4.1. MV ELECTRICITY NETWORK OF KARABÜK UNIVERSITY DEMİR ÇELİK CAMPUS

There are a total of nine transformers in the electrical network of the Karabük University Demir Çelik campus, seven of which are 1000 KVA and two are 800 KVA. The primary windings (input) of all transformers are connected to the 34.5 kV MV city network and the secondary windings (output) of the transformers are 0.4/0.231 kV.

The electricity distribution network of Karabük University Demir Çelik campus is fed through the medium voltage network belonging to TEDAŞ (Türkiye Elektrik Dağıtım AŞ.-Turkish Electricity Distribution Corporation). After the medium voltage line enters the university, it is transmitted to the medium voltage distribution lines through the busbars in the medium voltage distribution building and is transferred to the low voltage network in the university.

Table 4.1. Transformers, their power and the fields they feed.

Transformer	Power (kVA)	Feeding Zone
TR1-A	1000	Faculty of Technology, School of Foreign languages
TR1-B	800	Rectorate, Faculty of Medicine
TR2	1000	B3 and B4 Buildings, Heat Center, Gym
TR3	1000	Mosque, Faculty of economics, Social Life Center
TR4	1000	Faculty of Theology, Student affairs office
TR5	1000	Library, New Gym
TR6	800	Engineering faculty
TR7	1000	Stadium
TR8	1000	Research and development building

Solar energy systems have also been installed in some buildings on the campus. In these buildings, loads are fed from the solar energy system during daylight hours, and if the solar energy system is insufficient, the loads are fed by the grid. In Table 4.2, the buildings where solar energy panels are installed and their power are given.

Table 4.2. Locations of solar energy panels and their power.

Location (Building)	Power (kW)
Gym	50
Vocational School of Foreign Languages	250
Faculty of Technology	300
Faculty of Theology	100
Faculty of Economics and Administrative Sciences	300

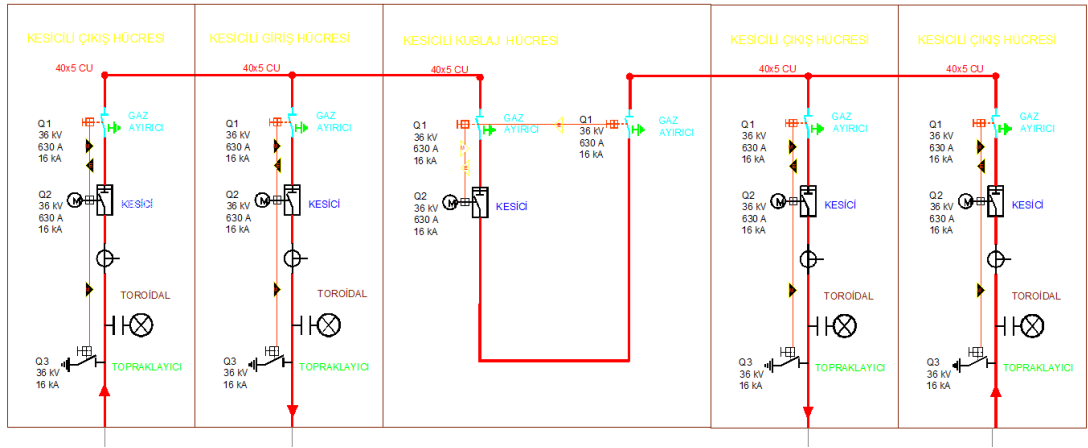

Figure 4.1. TEDAS MV UNI-1 and UNI-2 feeders.

There are two separate MV lines, UNI-1 and UNI-2, feeding the Karabuk University. The cable length between the TEDAŞ (Türkiye Elektrik Dağıtım AŞ.-Turkish Electricity Distribution Corporation) feeder cell and the MV entrance cell of the university is 438 m. For these two lines, XLPE cables with a cross section of $3 \times (1 \times 95 + 16) \text{ mm}^2$ have been used. TEDAS output feeders feeding Karabük University are shown in Figure 4.1. University entrance MV cells (UNI-1 and UNI-2) are given in Figure 4.2.

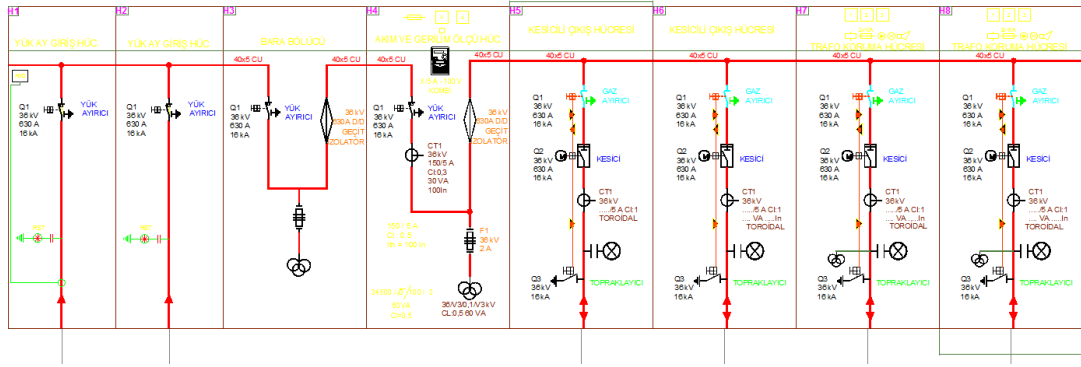

Figure 4.2. University entrance UNI-1 and UNI-2 feeders

University entrance MV cells are in the transformer kiosk where TR1-A and TR1-B transformers are located. Here, both TR1-A and TR1-B are fed and the output of MV is fed to other transformers. There are two MV outputs in the TR1 transformer cubicle. One of them goes to the transformer kiosk where TR2 is located and the other goes to the transformer kiosk where TR8 is located. The MV feeder line to TR2 is 562m long 3x(1x95+16) mm² XLPE cable. The MV feeder line to TR8 is 1110m long 3x(1x95+16) mm² XLPE cable. TR2 and TR8 MV cells are depicted in Figure 4.3 and 4.4.

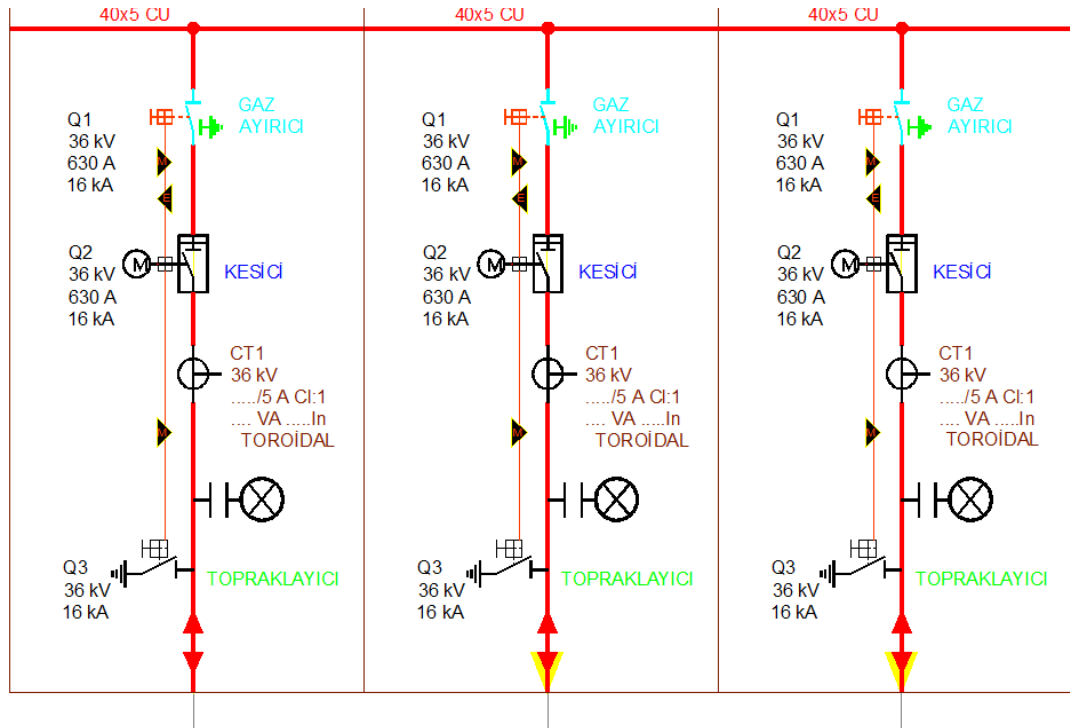

Figure 4.3. TR2 MV CB and Protection Cubicles

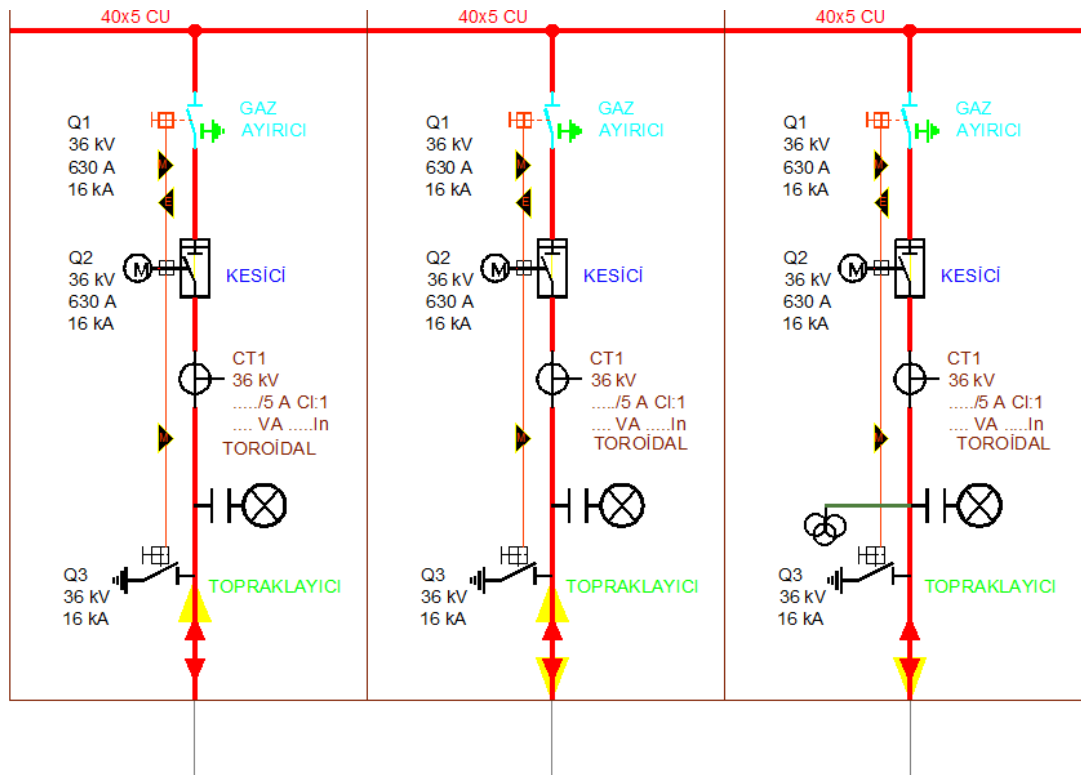

Figure 4.4. TR8 MV CB and protection cubicles.

There are three cubicles in the TR2 kiosk: a circuit breaker cubicle coming from TR1, a circuit breaker cubicle going to TR3, and a transformer protection cubicle feeding TR2. The length of the line to TR3 is 250m $3 \times (1 \times 95 + 16) \text{ mm}^2$ XLPE cable.

There are three cubicles in the TR8 kiosk: a circuit breaker cubicle coming from TR1, a circuit breaker cubicle going to TR7 and a transformer protection cubicle feeding TR8. The line to TR7 is 810m long $3 \times (1 \times 95 + 16) \text{ mm}^2$ XLPE cable.

There are three cubicles in the TR3 kiosk: a circuit breaker cubicle coming from TR2, a circuit breaker cubicle going to TR4 and a transformer protection cubicle feeding TR3. The length of the line to TR4 is 277m $3 \times (1 \times 95 + 16) \text{ mm}^2$ XLPE cable.

There are three cubicles in the TR7 kiosk, a circuit breaker cubicle coming from TR8, a circuit breaker cubicle going to TR6 and a transformer protection cubicle feeding TR7. The line to TR7 is 400m long 3x(1x95+16) mm² XLPE cable.

There are three cubicles in the TR4 kiosk: a circuit breaker cubicle coming from TR3, a circuit breaker cubicle going to TR5 and a transformer protection cubicle feeding TR4. The length of the line to TR5 is 325m 3x(1x95+16) mm² XLPE cable.

There are three cubicles in the TR6 kiosk: a circuit breaker cubicle coming from TR7, a circuit breaker cubicle going to TR5 and a transformer protection cubicle feeding TR6. The line to TR5 is 260m long 3x(1x95+16) mm² XLPE cable. Figures 4.7 and 4.8 show MV cell single-line diagrams of TR4 and TR6.

There are three cubicles in the TR5 kiosk, two circuit breaker cubicles coming from TR4 and TR6, and a transformer protection cubicle feeding TR5. In Figure 4.5, single line diagram of TR5 MV cell has been given.

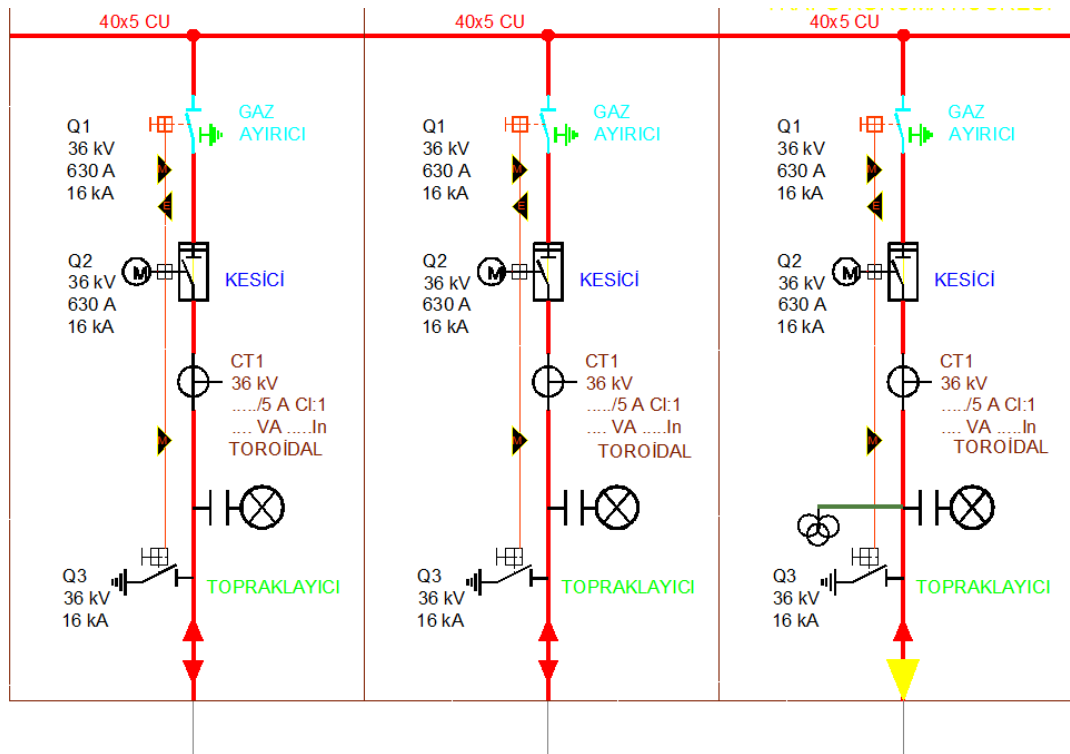

Figure 4.5. TR5 MV CB and Protection Cubicles

4.2. LV ELECTRICITY NETWORK OF KARABÜK UNIVERSITY DEMİR ÇELİK CAMPUS

Each transformer connected to the MV network has its own feeding areas (Refer to Table 4.1) on the LV side as described in Chapter 4.1. The output of transformers is 0.4/0.231 kV. There are compensation panels for each transformer. As an example, LV single line diagram of TR3 is given in Figure 4.6.

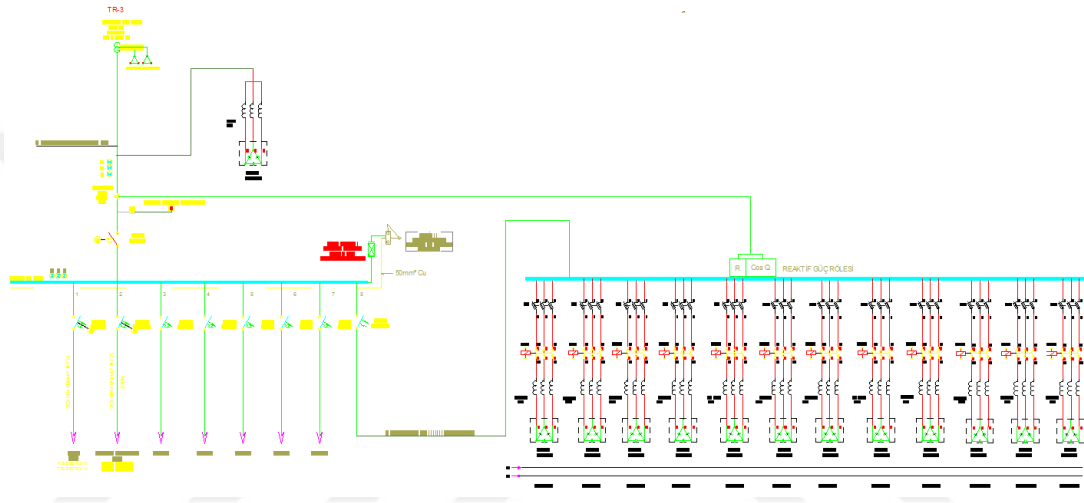

Figure 4.6. TR3 LV Single Line Diagram

In Demir Çelik campus, the power drawn from the transformers can be monitored on monthly and daily basis with the SCADA system. The analysis of the drawn power graphs is important as to analyze how the charging stations to be connected to the transformers will affect the loading rate of the transformers. There are six large parking lots on the Demir Çelik campus. The locations of the parking areas and the transformers to which the charging stations will be connected are given in Table 4.3. While choosing the transformers, the proximity (cable length) and the load rates of the transformers ought to be taken into account.

Table 4.3. Transformers to which parking areas and charging stations will be connected.

Parking lots	Transformer to be connected to
Rectorate Building	TR1-B
FEAS	TR3
Student Affairs (Across the Mosque)	TR3
Faculty of Theology	TR4
Faculty of Engineering	TR6
Stadium	TR7

Since TR1-A, TR2, TR5 and TR8 charging stations cannot be connected, monthly and daily graphs of these transformers cannot be given here.

Graphs selected as examples from the data of the first five months of 2021 will be given separately for each region.

The Rectorate building and the Faculty of Medicine building are connected to TR1-B. Power analysis graphs of these buildings are given in Figures 4.7-4.12.

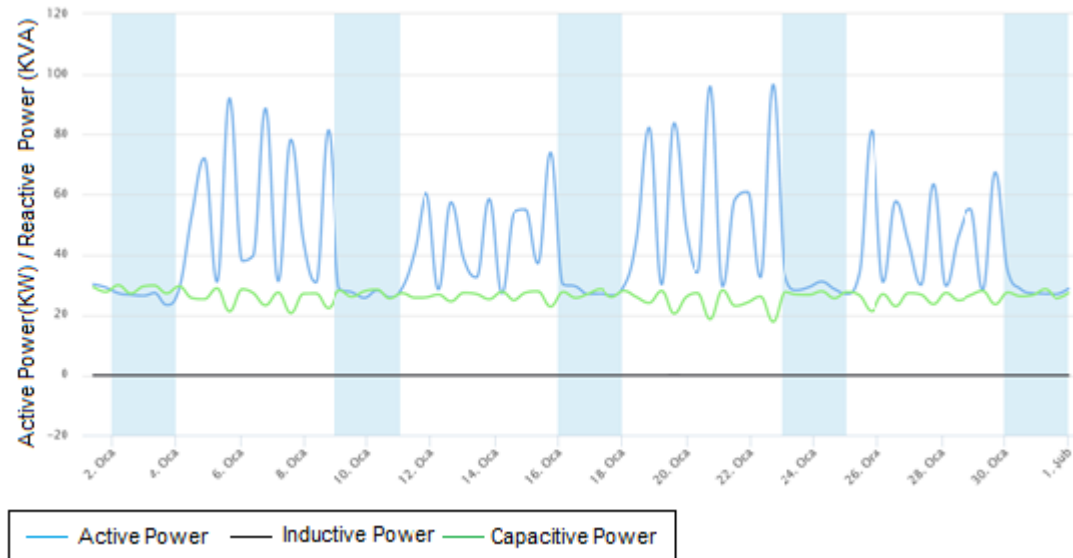

Figure 4.7. The power graph taken from the Rectorate building in January 2021.

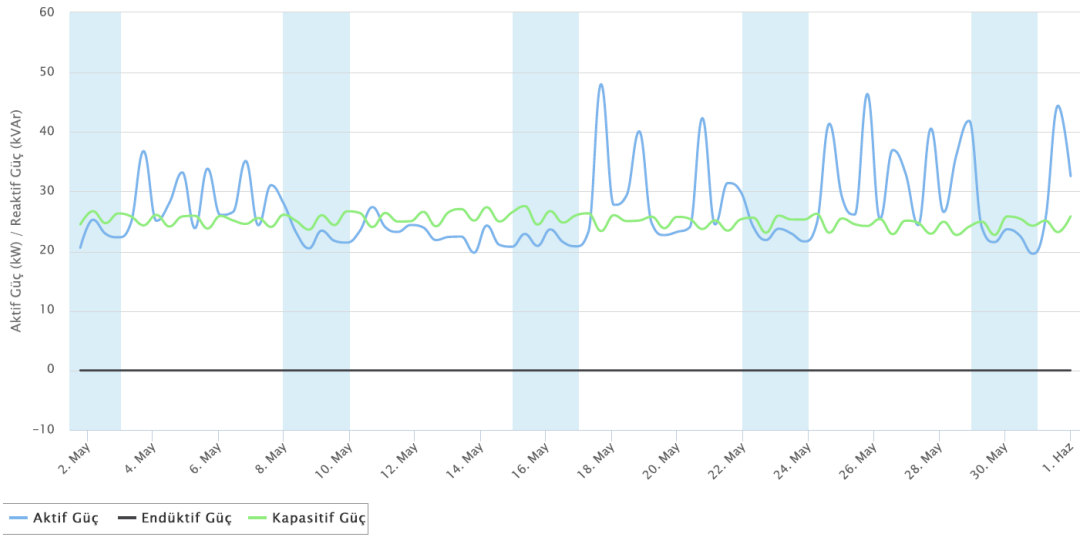

Figure 4.8. The power graph taken from the Rectorate building in May 2021.

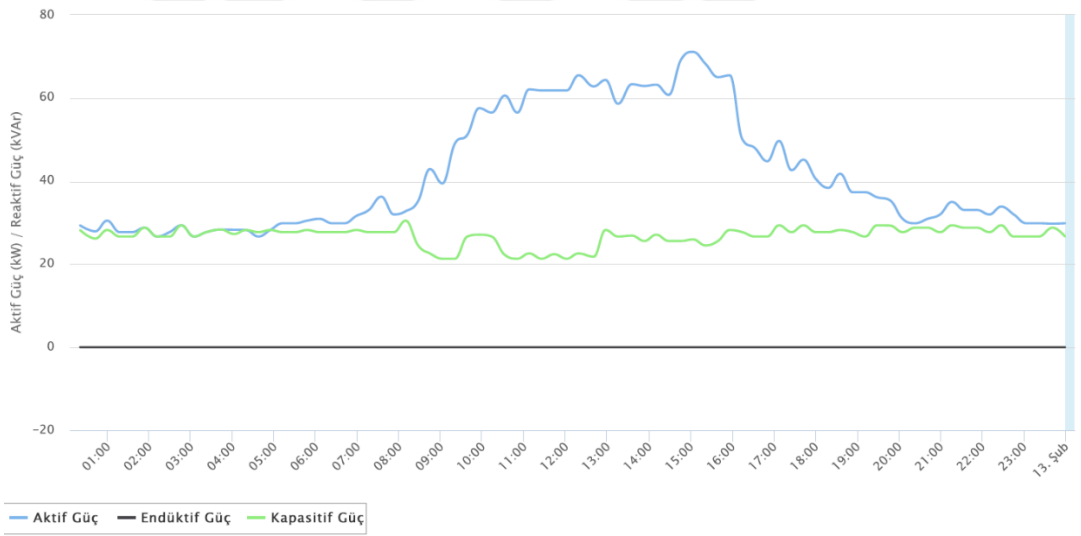

Figure 4.9. Power graph taken from Rectorate building in 12 February 2021.

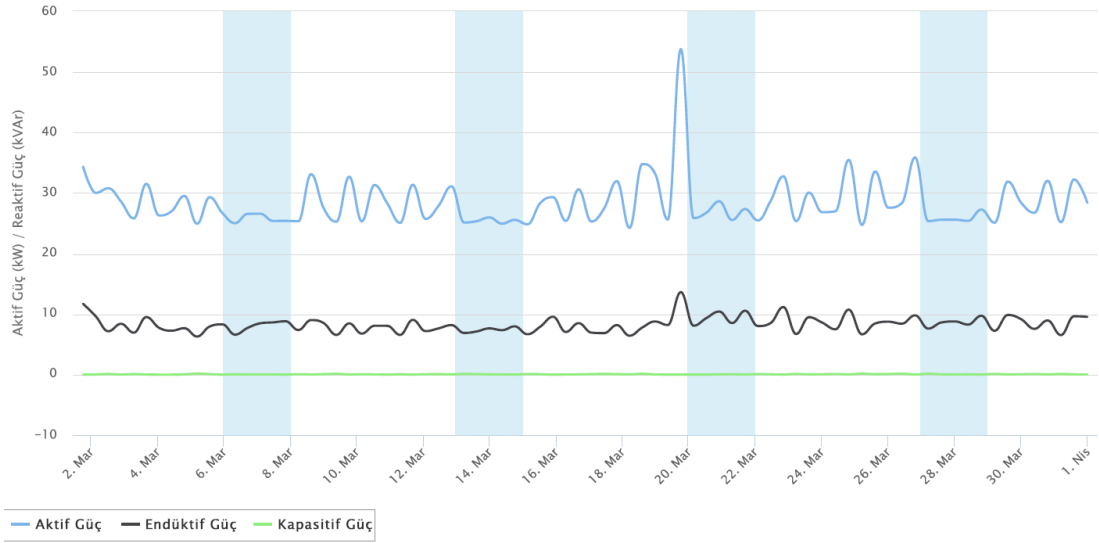

Figure 4.10. The power graph of the Faculty of Medicine building taken in March 2021.

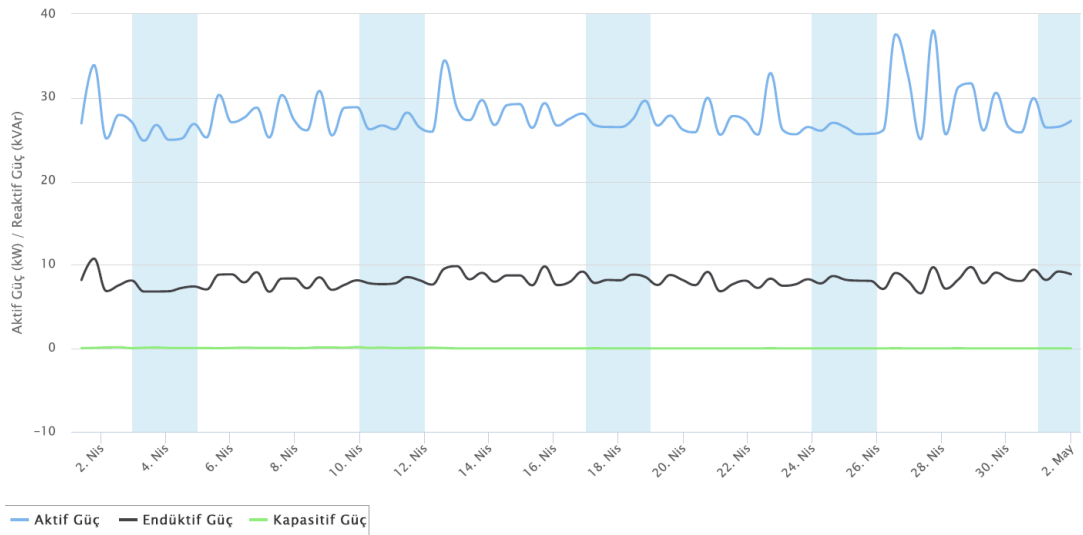

Figure 4.11. The power graph of the Faculty of Medicine building taken in April 2021.

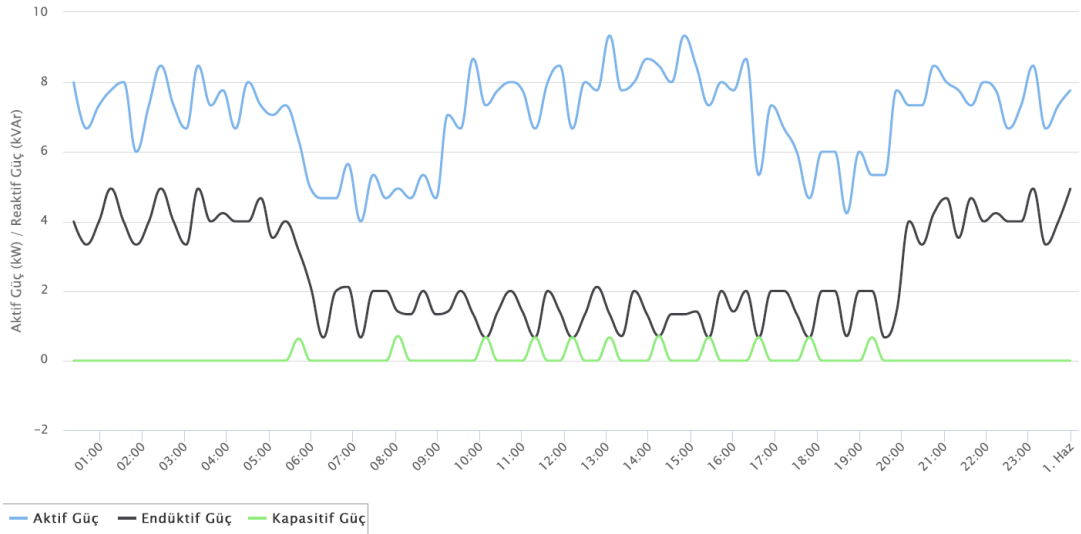

Figure 4.12. The power graph of the Faculty of Medicine building, taken in May 31, 2021.

Since it takes up too much space, the graphs of all months and days are not included here. When the values of the five-month graphs of the Rectorate building and the Faculty of Medicine, which are connected to TR1-B, are examined, it is observed that the total instantaneous or daily maximum (peak) power is 150-200 KVA.

The monthly and daily power graphs of the FEAS (Faculty of Economics and Administrative Sciences) and Social Life Center connected to TR3 are shown in Figures 4.13-4.19.

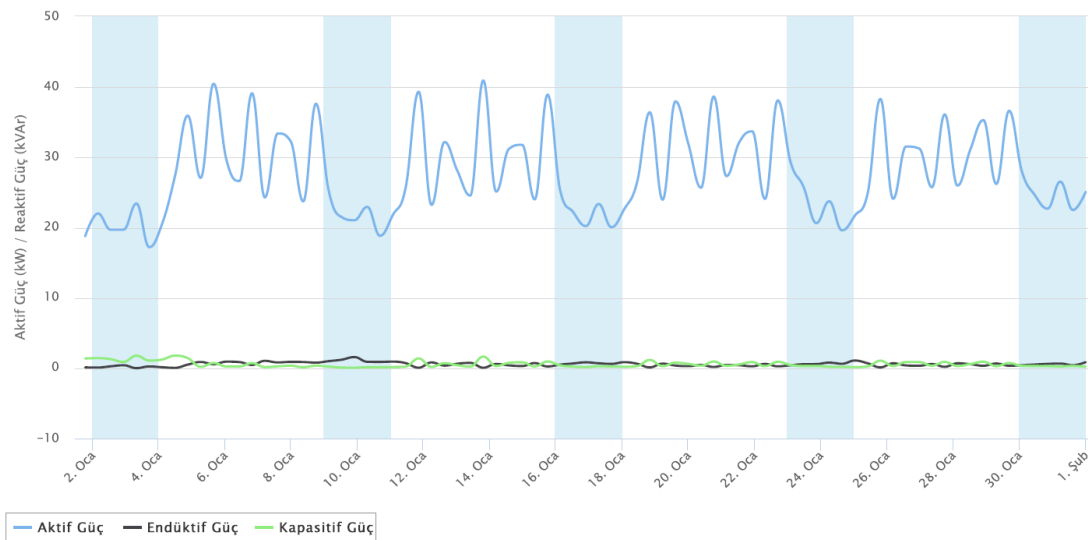

Figure 4.13. The power graph of the FEAS building taken in January 2021.

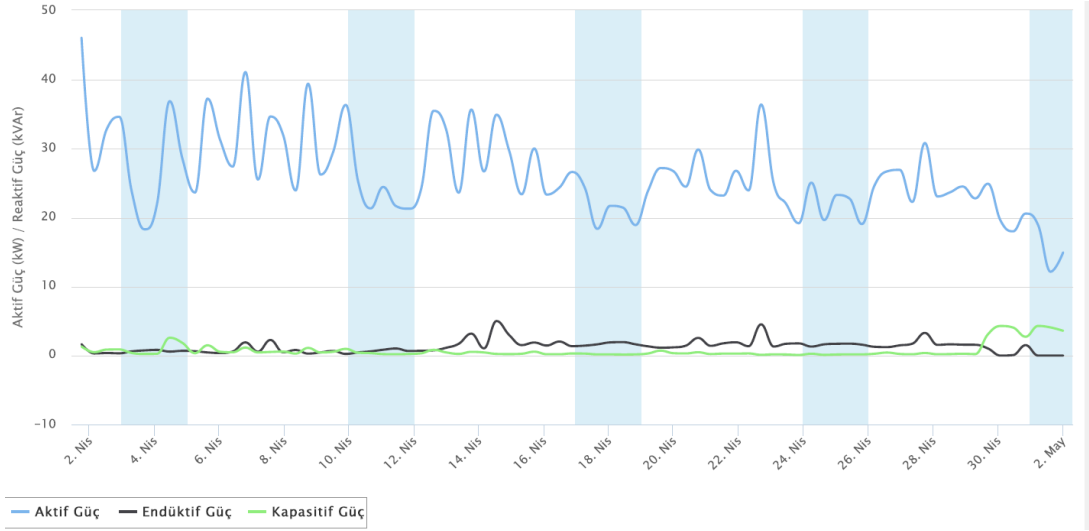

Figure 4.14. The power graph of the FEAS building taken in April 2021

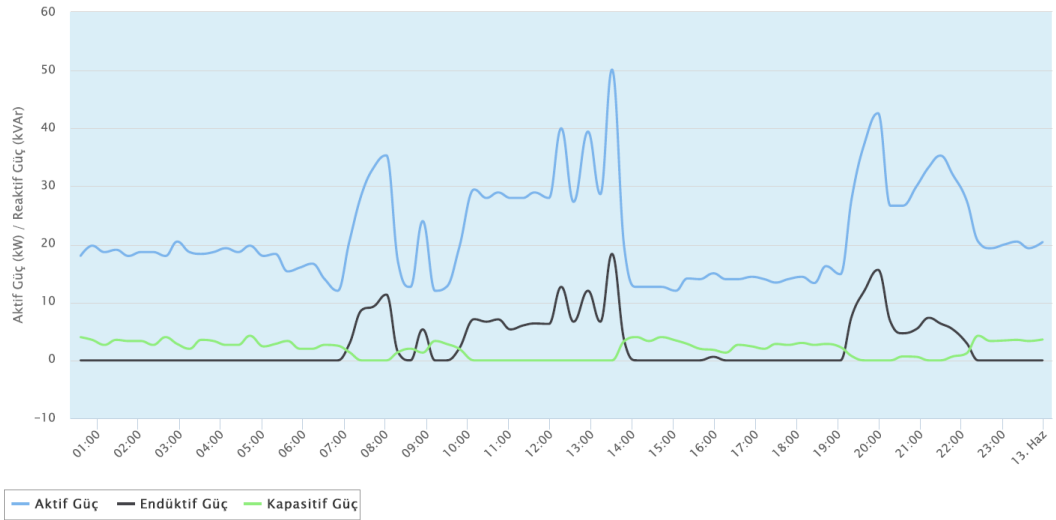

Figure 4.15. The power graph of the FEAS building taken in June 12, 2021.

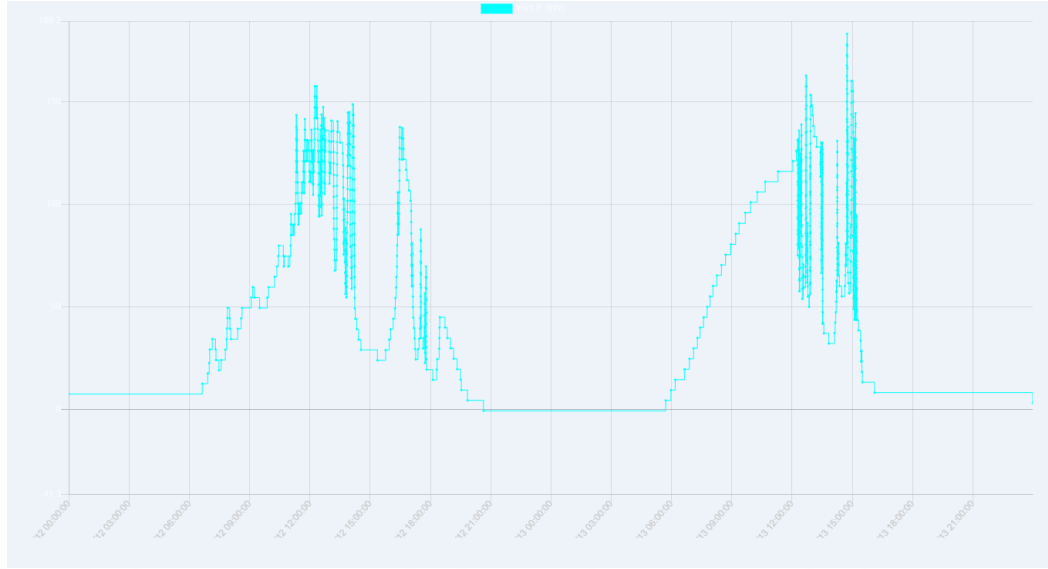

Figure 4.16. The SES (solar energy) graph of FEAS building taken in June,12 2021.

There is a 300 KVA solar energy system (SES) in the FEAS building. Especially in summer and during the daytime in sunny weather, SES alone meets all the needs of the building. In cloudy weather and/or at night when the SES is insufficient, the building is fed from the mains.

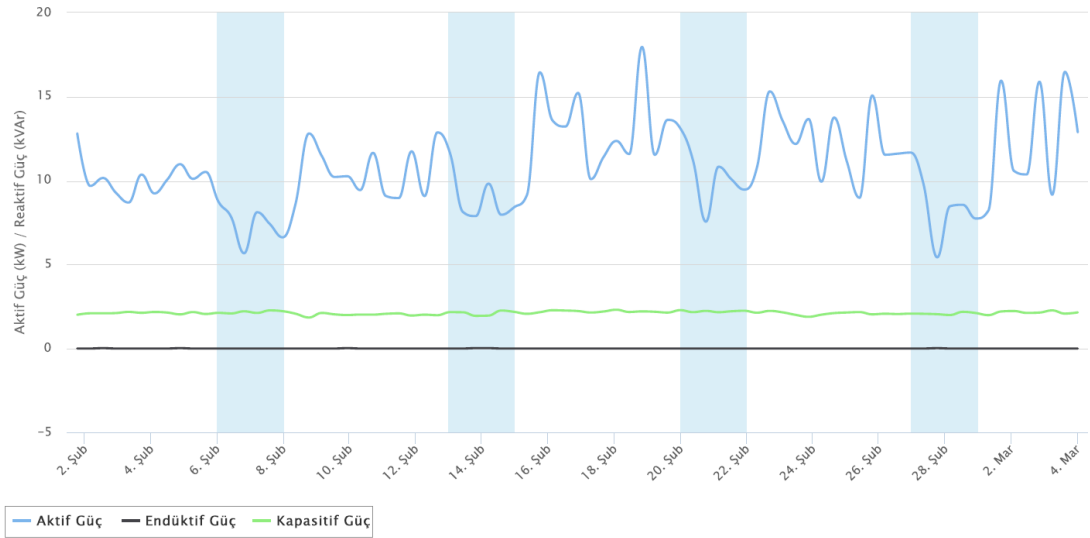

Figure 4.17. Power graph of Social Life Center building taken in February 2021.

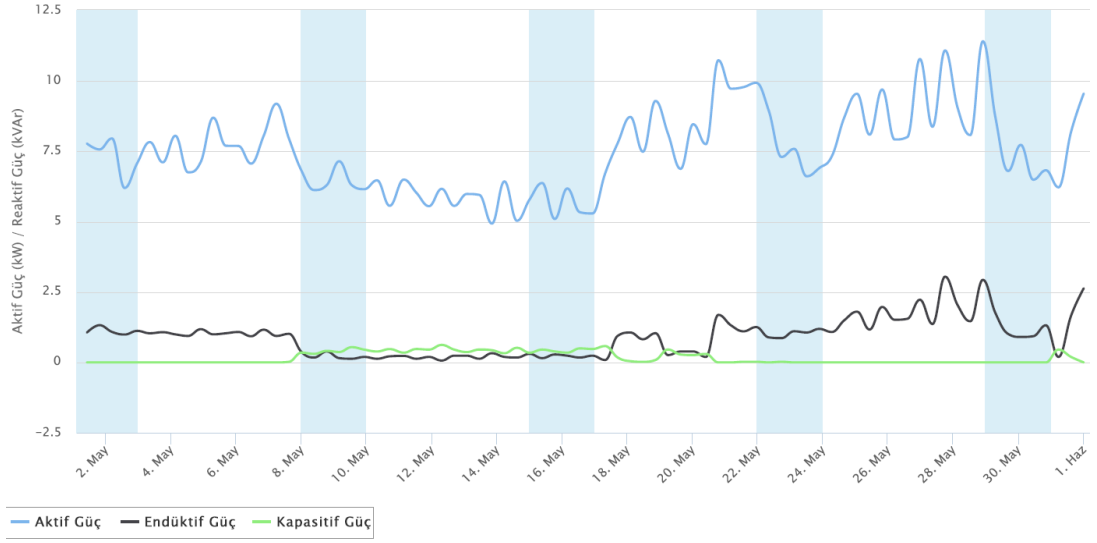

Figure 4.18. The power graph of the Social Life Center building taken in may 2021.

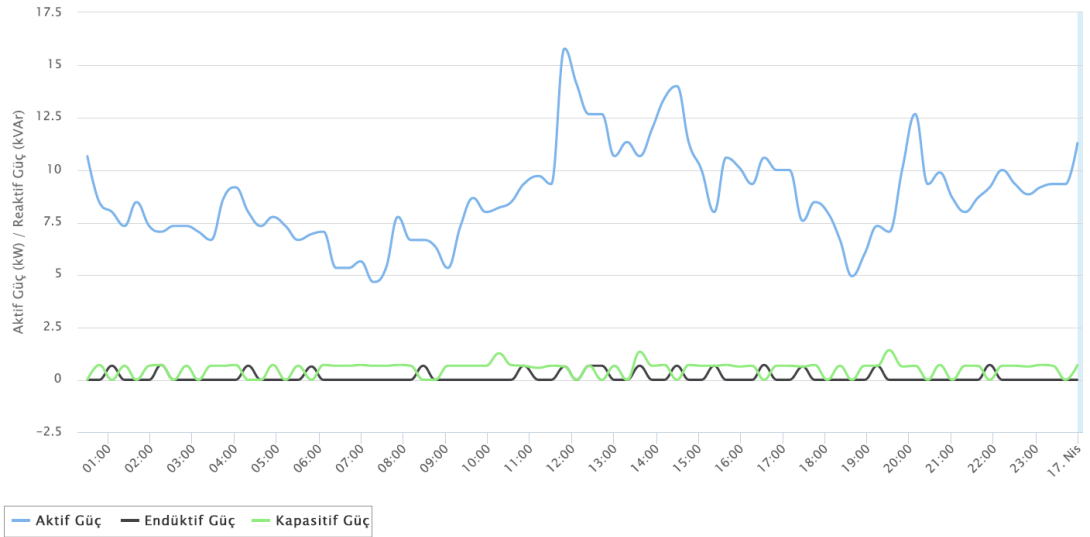

Figure 4.19. The power graph of the Social Life Center building taken in April 16, 2021.

When the monthly and daily power graphs of FEAS and Social Life Center connected to TR3 are examined, it is observed that the total power drawn is 50-60 KVA on average. The power drawn from the network (transformer) decreases considerably, especially in summer and during the daylight hours, thanks to the 300 KVA SES installed in FEAS.

The monthly and daily power graphs of the Faculty of Theology and Student Affairs buildings connected to TR4 are given in Figures 4.24-4.29.

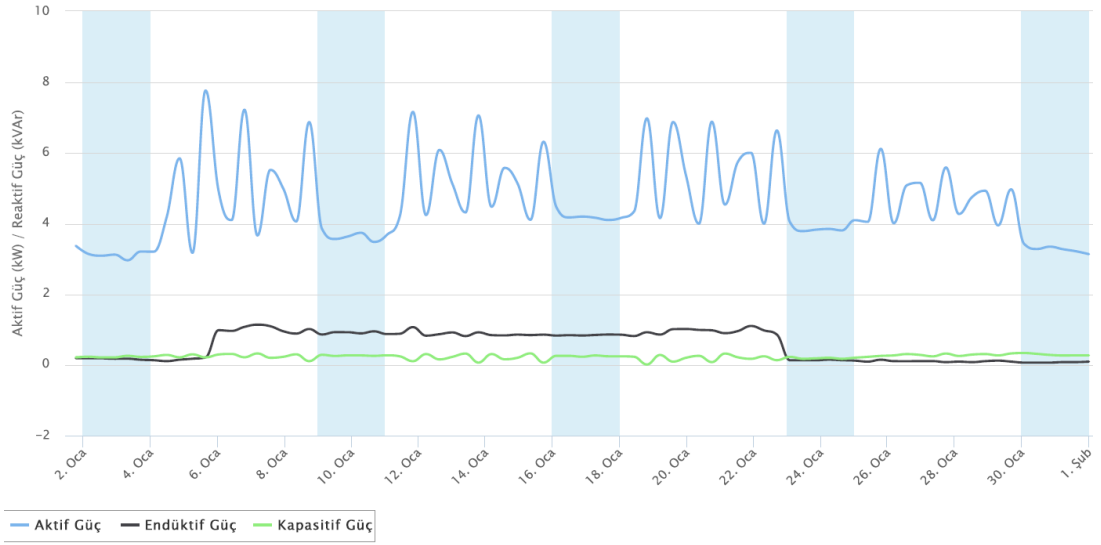

Figure 4.20. The power graph of the Faculty of Theology building taken in January 2021.

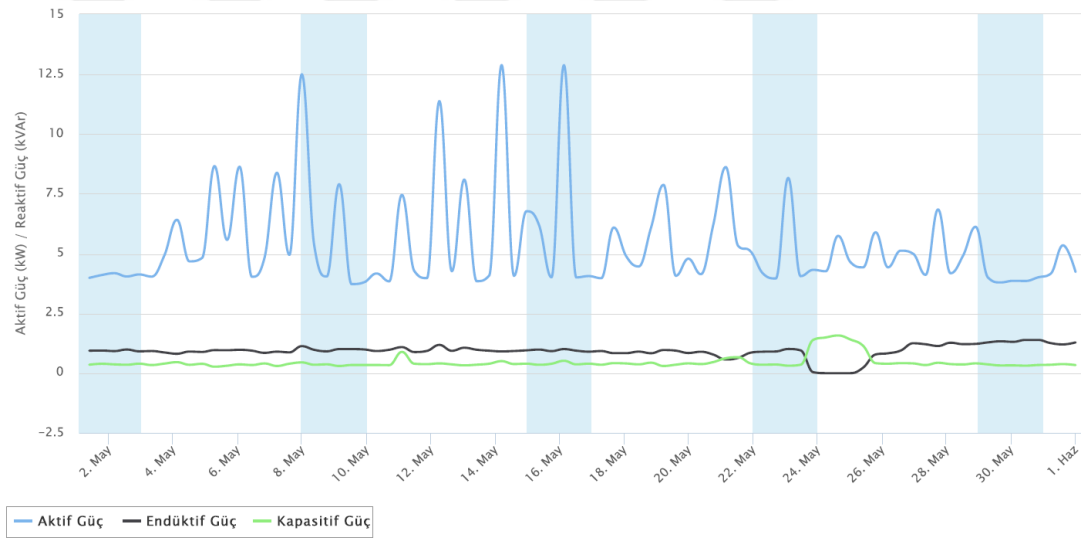

Figure 4.21. The power graph of the Faculty of Theology taken in May 2021.

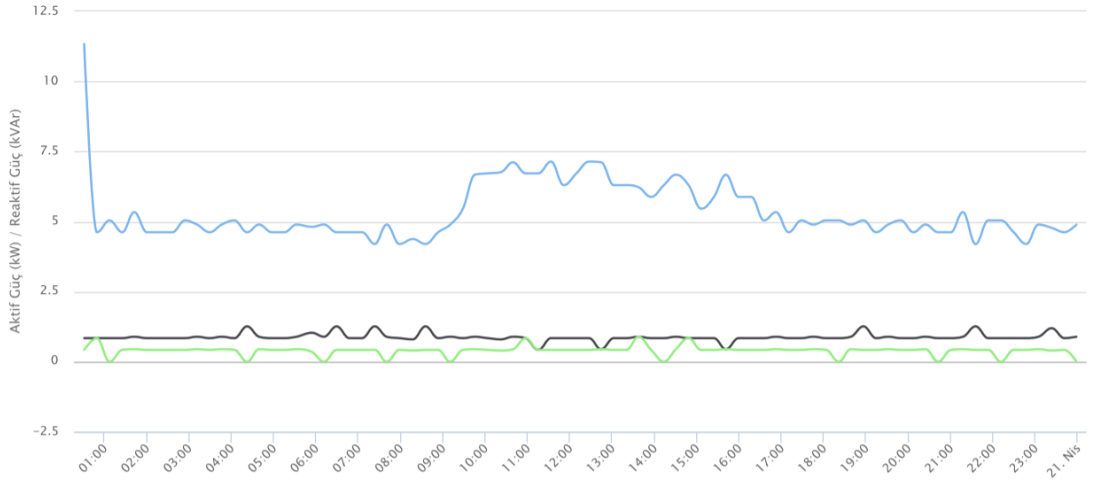

Figure 4.22. The power graph of the Faculty of Theology building taken in April 20, 2021.

There is a 100 KVA SES in the Faculty of Theology. Especially in summer and during daylight hours, loads are fed from the solar energy system.

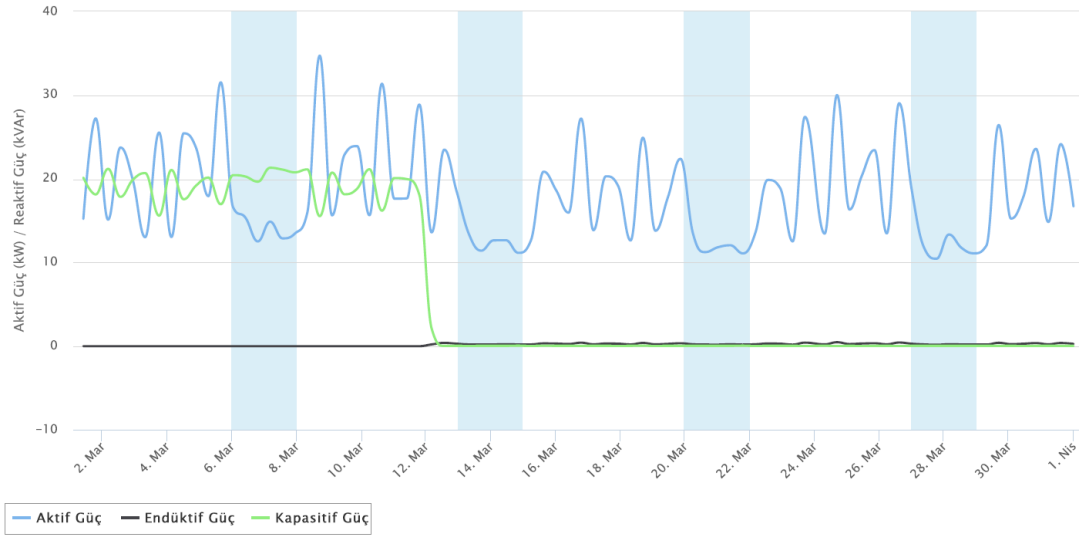

Figure 4.23. Student Affairs building power graph taken in March 2021.

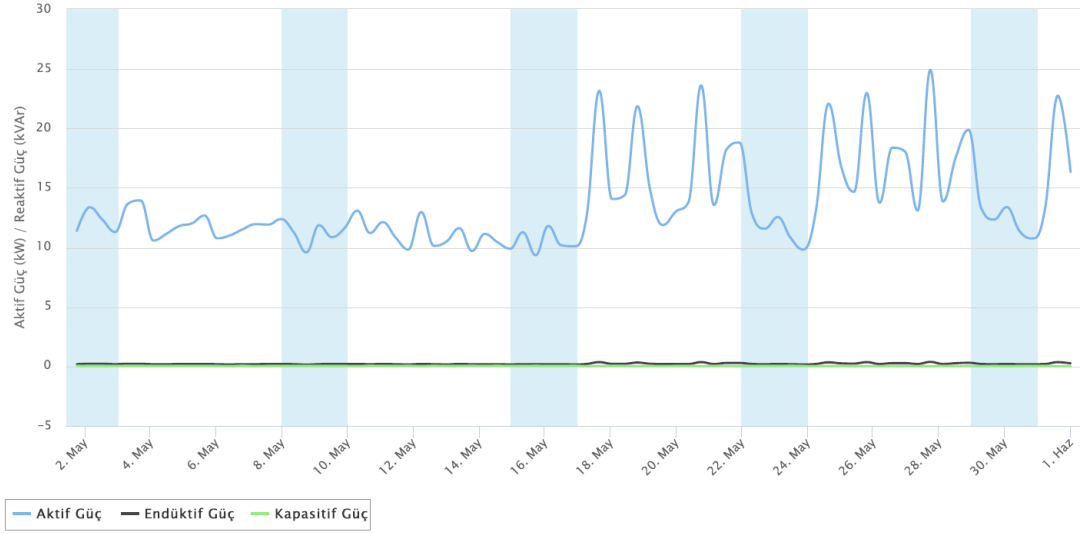

Figure 4.24. Student Affairs building power graph taken in May 2021.

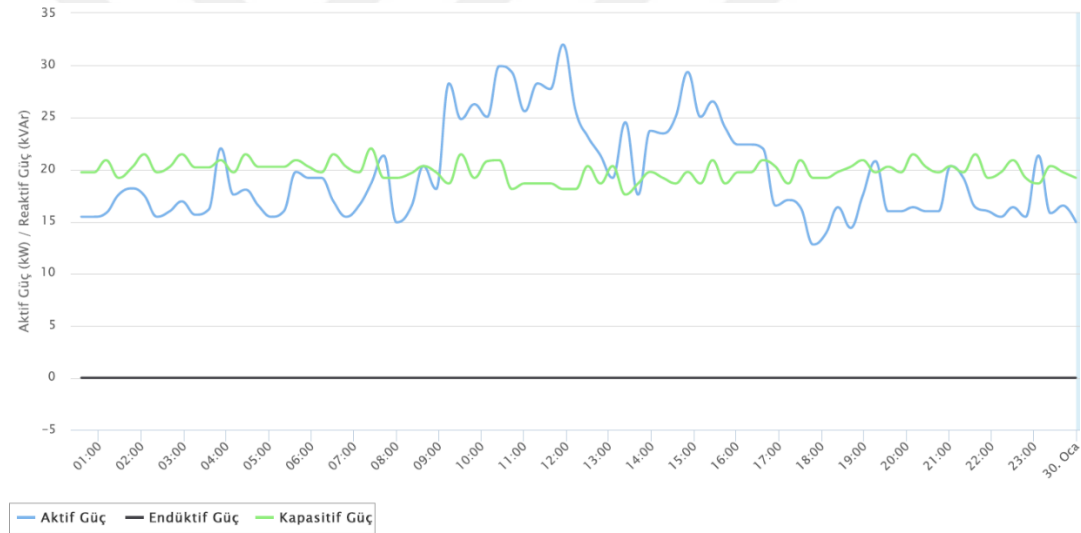

Figure 4.25. The power graph of the Student Affairs building taken in January 30, 2021.

When the monthly and daily power graphs of the Faculty of Theology and Student Affairs buildings connected to TR4 are examined, it is observed that the total power drawn is 40-60 KVA on average. The power drawn from the mains (transformer) decreases considerably, especially in summer and during the daylight hours, thanks to the 100 KVA SES installed at the Faculty of Theology.

The monthly and daily power graphs of the Faculty of Engineering building connected to TR6 are given in Figures 4.26-4.28.

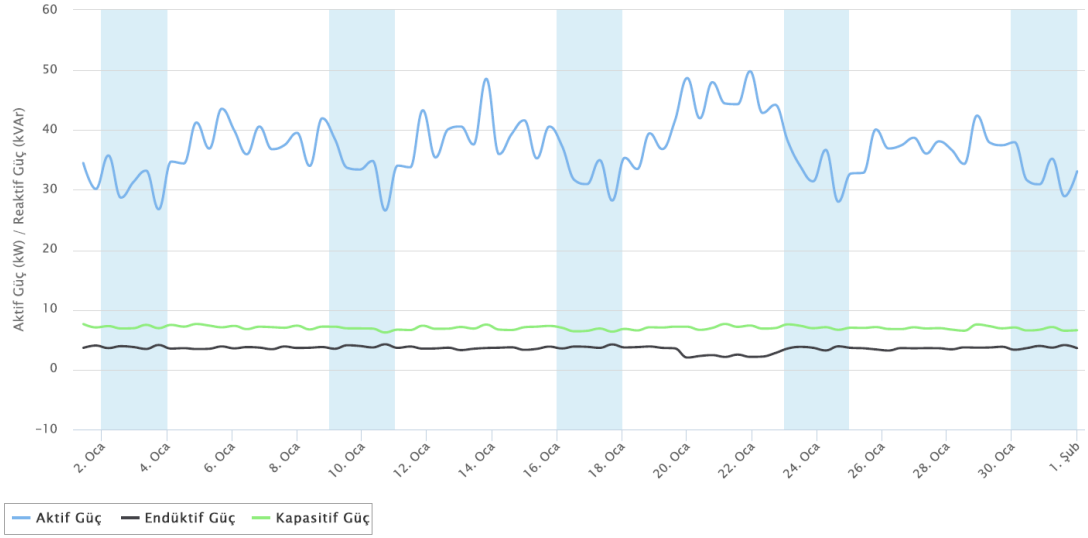

Figure 4.26. The power graph of the Faculty of Engineering building taken in January 2021.

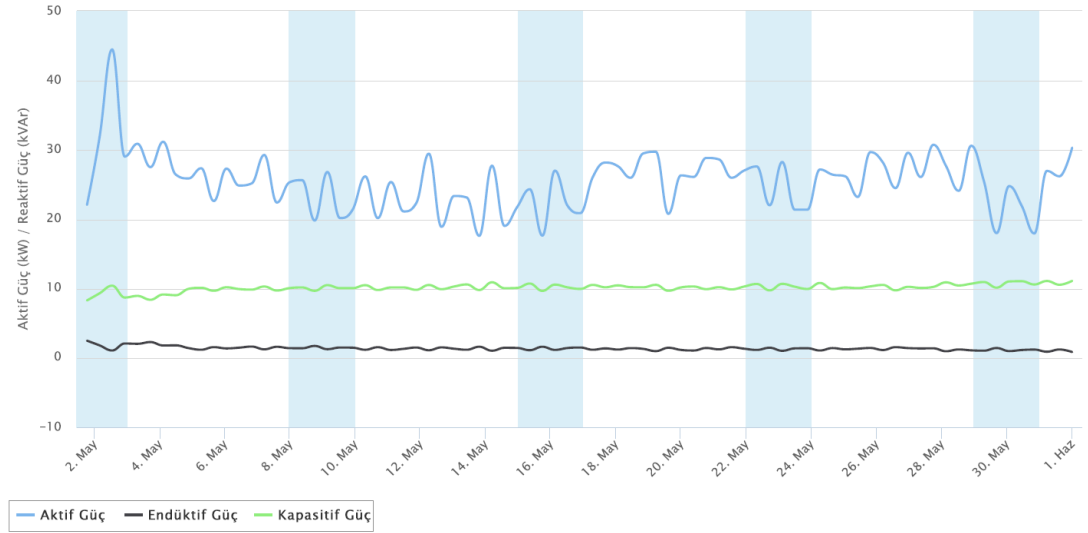

Figure 4.27. The power graph of the Faculty of Engineering building taken in May 2021.

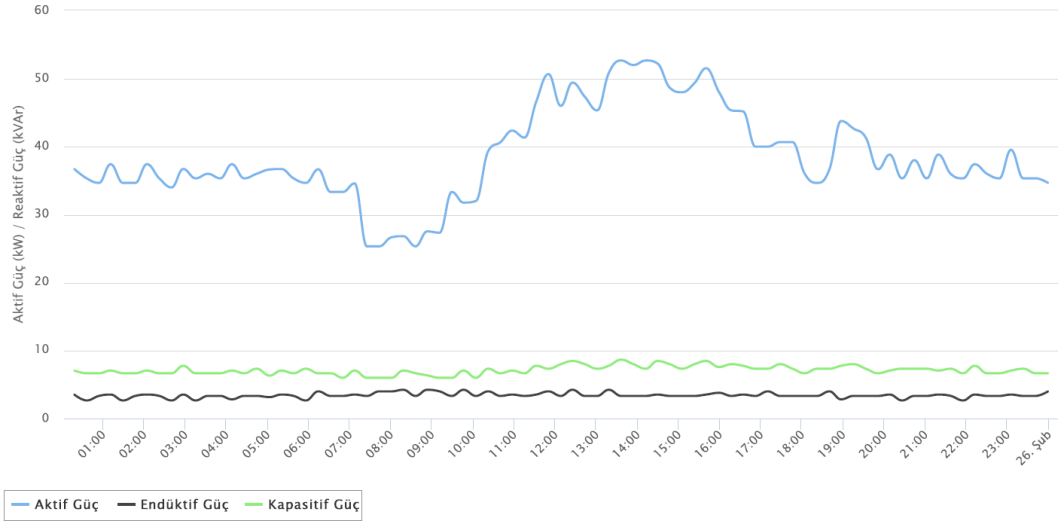

Figure 4.28. The power graph taken from the Faculty of Engineering in February 25, 2021.

When the monthly and daily power graphs of the Engineering Faculty building, which is connected to TR6, are examined, it is seen that the total power drawn is 50-60 KVA on average.

Since the main electrical panel feeding the stadium which is connected to TR7 has not yet been included in the SCADA system, power graphics of TR7 could not be obtained. However, it has been determined that a maximum of 15-20 KVA power is drawn in daily and instant measurements. In addition, there are 400 KVA lamps that are activated rarely during night games.

When the graphs in Chapter 4.2 are examined, it is determined that the transformers are loaded at around 5-10% max.

4.3. EV CHARGING STATION SCENARIOS

Karabük University Demir Çelik campus has 6 large parking lots. These areas are located around the Rectorate building, in front of the FEAS building, around the Student Affairs building, in front of the Faculty of Theology building, around the Engineering Faculty and around the Stadium. The largest parking area is the parking area around the Student Affairs building. By taking into account the proximity of the car parks to the transformers (cable distance), the loading rates of the transformers and

the size of the car parks (number of vehicles), it was estimated that from which transformers the EV charging stations to be placed in the car parks could be fed, and were given in Table 4.3. In this chapter, load analysis, network modeling and simulations will be made according to the number of EVs that can be found in the Demir Çelik campus and the number of charging stations required for these vehicles for the years 2025, 2030 and 2040.

4.3.1. 2025 Charging Station Scenario

An estimated number of personnel and vehicles for 2021, 2025, 2030 and 2040 across Karabük University have been given in Table 4.4. These figures are approximate estimates obtained by discussions with the relevant units of the University. Figures given are for the whole university. However, the majority of these figures (80%) are expected to be seen in the Demir Çelik campus.

Table 4.4. Estimation of the number of personnel and vehicles by years.

Year	Number of Personnel	Number of Vehicles
2021	1900	1206
2025	2150	1370
2030	2450	1570
2040	3050	2100

The scenario predicted for 2025 will be created according to the figures given in Table 4.4, taking into account the 15% student vehicle and 5% guest vehicle share (80% of the entire university + 15% + 5%). Accordingly, the figures given in Table 4.4 can be used directly.

Assuming that 25% of the vehicles will be EVs for 2025, the number of charging stations and the area where they will be placed have been studied according to 343 EV vehicles.

Considering the size of the parking lots on the Demir Çelik campus and the density of personnel and/or vehicles in that area, 20% of the vehicles will be in the Rectorate

parking lot, 10% in the FEAS parking lot, 30% in the Student Affairs parking lot, 10% in the Faculty of Theology parking lot, 20% in the Faculty of Engineering parking lot and 10% will be in the Stadium parking lot.

Table 4.5. Number of EVs in parking lots according to 2025 scenario.

Parking lots	Number of EVs	Transformer to be connected to
Rectorate	68	TR1-B
FEAS	34	TR3
Student Affairs (Across the Mosque)	103	TR3
Faculty of Theology	34	TR4
Faculty of Engineering	68	TR6
Stadium	34	TR7

According to the regulation, the number of sockets must be between 2% and 5% of the parking lot vehicle capacity (number of vehicles). In our case, the upper limit of 5% will be taken. Since there will be 2 sockets at 22 kW charging stations to be placed on the campus, the number of charging stations is calculated by dividing the number of vehicles by 40. Accordingly, the anticipated number of charging stations for parking lots is given in Table 4.6.

Table 4.6. Number of EV Charging Stations in parking lots according to 2025 scenario.

Parking lots	Number of EV Stations	Transformer to be connected to
Rectorate	2	TR1-B
FEAS	1	TR3
Student Affairs (Across the Mosque)	3	TR3
Faculty of Theology	1	TR4
Faculty of Engineering	2	TR6
Stadium	1	TR7

According to this table, a load of 44 kW (5.5%) is added to TR1-B, 88 kW (8.8%) to TR3, 22 kW (2.2%) to TR4, 44 kW to TR6 5.5%, and 22 kW (2.2%) load is added to TR7. The values have been given in Table 4.7 as follows.

Table 4.7. The additional load of EV Charging Stations according to the 2025 scenario.

Parking lots	EV load (kW)	Transformer to be connected to
Rectorate	44	TR1-B
FEAS	22	TR3
Student Affairs (Across the Mosque)	66	TR3
Faculty of Theology	22	TR4
Faculty of Engineering	44	TR6
Stadium	22	TR7

Referring to the data in the graphs and tables given in Chapter 4.1, 4.2 and 4.3, the additional load that the EV charging stations will bring to the transformers according to the 2025 scenario is at a level that can be easily met by the transformers. Considering the general increase in electrical loads until 2025, it is estimated that the transformers will be loaded around 10-15% max.

In the scenarios, only light vehicles (not trucks, lorries, minibusses, etc.) have been considered. By evaluating the estimates of EV numbers in the world and in Turkey over the next 20 years and considering the EV usage trend of university staff, EV numbers have been taken slightly higher than expected. The reason for this is to see the loading condition of the transformers on a larger scale.

ETAP single line diagram of the MV network and single line diagram of 2025 scenario are shown in Figures 4.29 and 4.30.

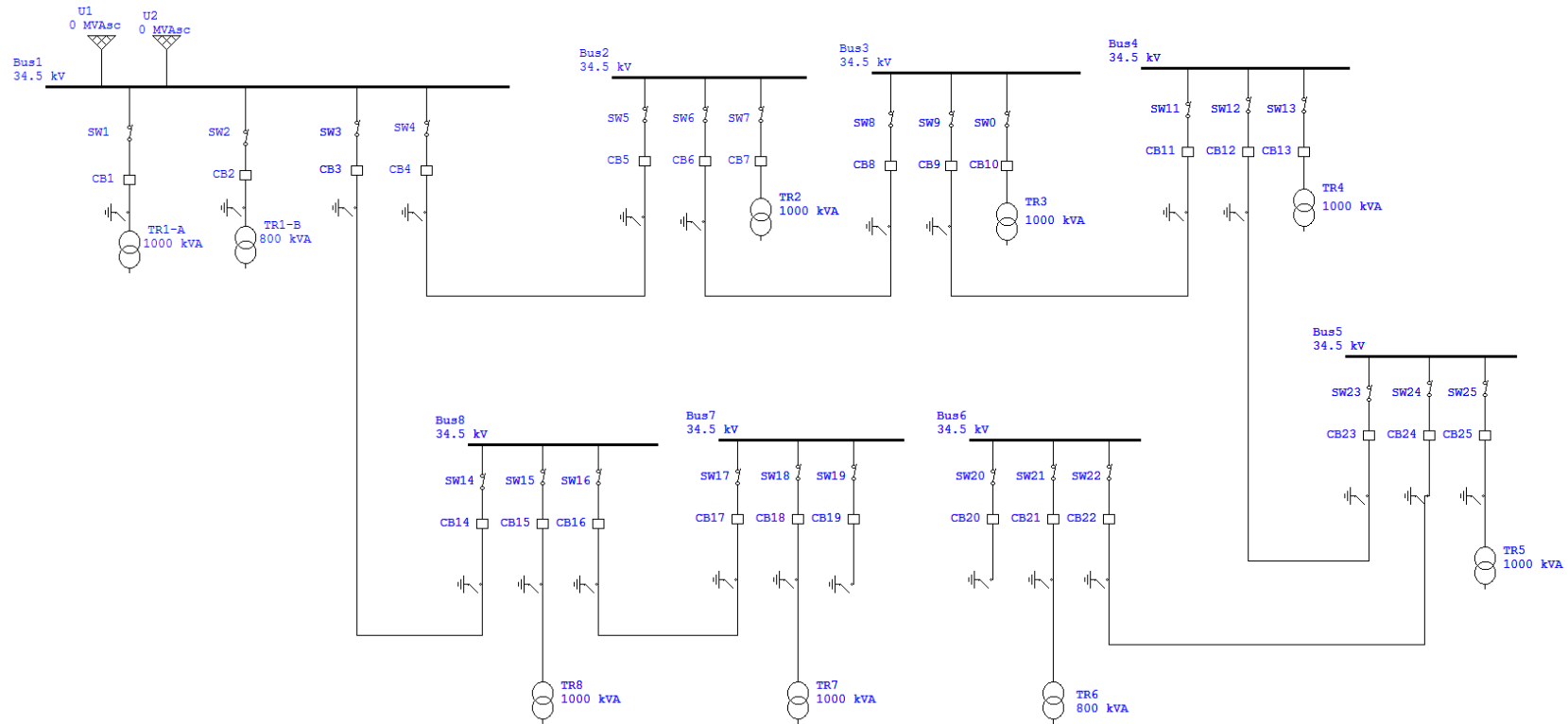

Figure 4.29. ETAP single line diagram of the MV network.

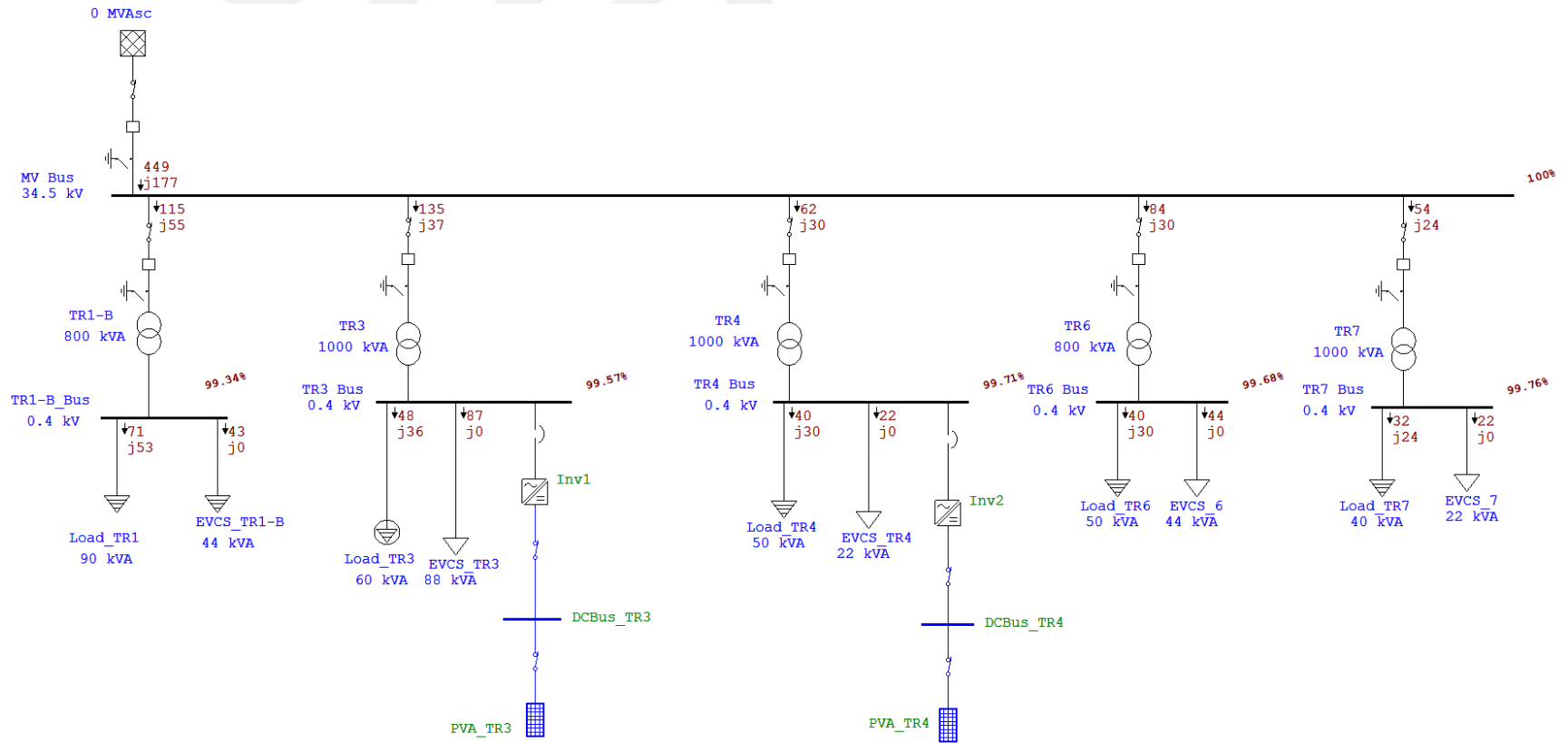

Figure 4.30. ETAP single line diagram of 2025 scenario.

4.3.2. 2030 Charging Station Scenario

The number of charging stations and the areas where they will be placed have been studied according to 785 EV vehicles assuming that 50% of the vehicles will be EVs for 2030.

According to the explanations made in Chapter 4.3.1, the 2030 scenario EV number has been given in Table 4.8 and the number of charging stations has been given in Table 4.9.

Table 4.8. Number of EVs in parking lots according to 2030 scenario.

Parking lots	Number of EVs	Transformer to be connected to
Rectorate	157	TR1-B
FEAS	79	TR3
Student Affairs (Across the Mosque)	236	TR3
Faculty of Theology	79	TR4
Faculty of Engineering	157	TR6
Stadium	79	TR7

Table 4.9. Number of EV Charging Stations in car parks according to 2030 scenario.

Parking lots	Number of EV Stations	Transformer to be connected to
Rectorate	4	TR1-B
FEAS	2	TR3
Student Affairs (Across the Mosque)	6	TR3
Faculty of Theology	2	TR4
Faculty of Engineering	4	TR6
Stadium	2	TR7

According to this table, TR1-B is loaded with 88 kW (11%), TR3 with 176 kW (17.6%), TR4 with 44 kW (4.4%), TR6 with 88 kW (11%) and TR7 is loaded with 44 kW (4.4%) load. The values have been given in Table 4.10 as follows.

Table 4.10. The additional load to be brought by EV Charging Stations according to the 2030 scenario.

Parking lots	EV load (kW)	Transformer to be connected to
Rectorate	88	TR1-B
FEAS	44	TR3
Student Affairs (Across the Mosque)	132	TR3
Faculty of Theology	44	TR4
Faculty of Engineering	88	TR6
Stadium	44	TR7

According to the data in the graphs and tables given in Chapters 4.1, 4.2 and 4.3, the additional load that the EV charging stations will bring to the transformers according to the 2030 scenario is at a level that can be easily met by the transformers. Considering the general increase in electrical loads until 2030, it is estimated that the transformers will be loaded around 15-25% max.

ETAP single line diagram of 2030 scenario is shown in Figure 4.31.

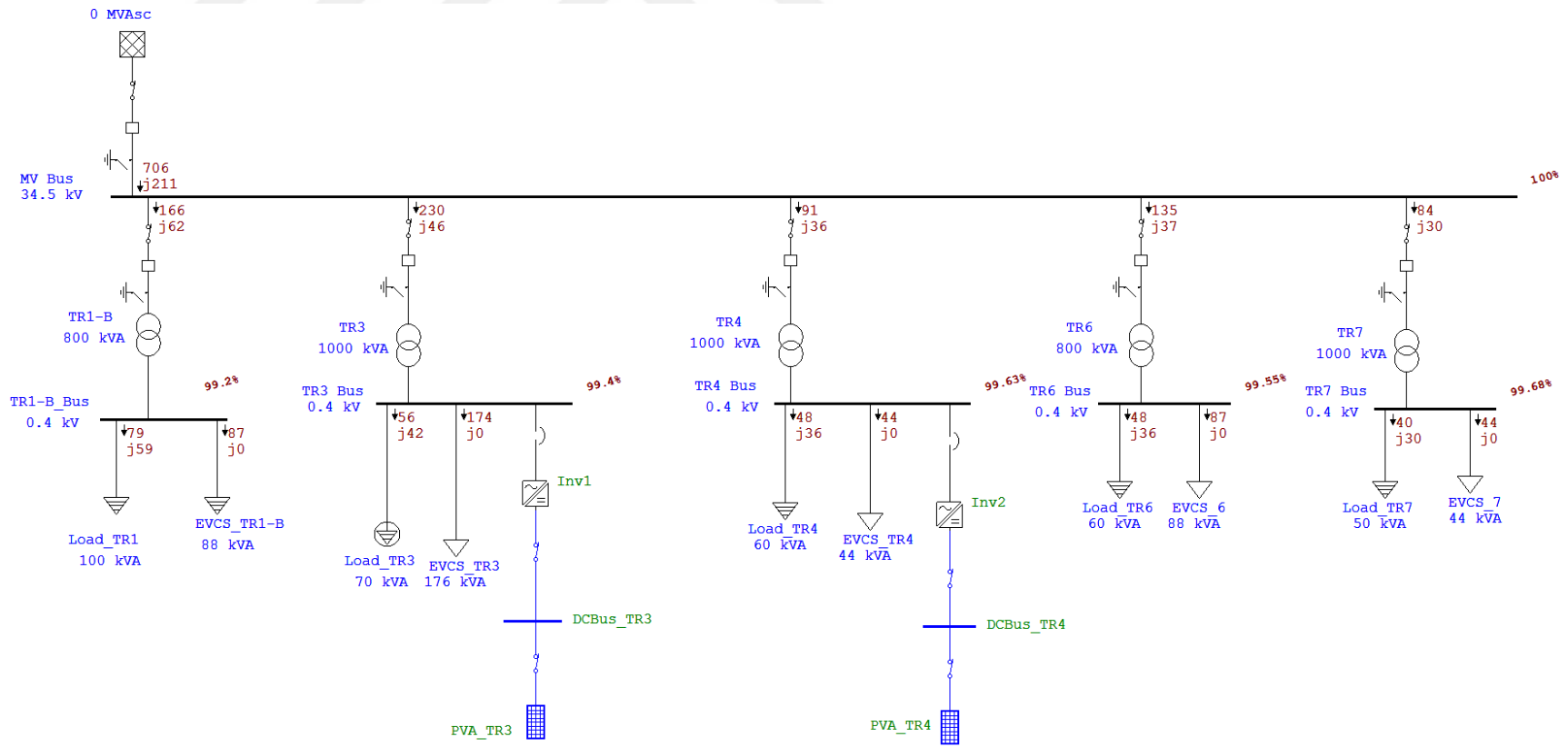

Figure 4.31. ETAP single line diagram of 2030 scenario.

4.3.3. 2040 Charging Station Scenario

Assuming that 100% of the vehicles will be EV for the year 2040, the number of charging stations and the areas where they will be placed have been studied according to 2100 EVs.

According to the explanations made in Chapter 4.3.1, the 2040 scenario EV number has been given in Table 4.11 and the number of charging stations has been given in Table 4.12.

Table 4.11. Number of EVs in parking lots according to 2040 scenario.

Parking lots	Number of EVs	Transformer to be connected to
Rectorate	420	TR1-B
FEAS	210	TR3
Student Affairs (Across the Mosque)	630	TR3
Faculty of Theology	210	TR4
Faculty of Engineering	420	TR6
Stadium	210	TR7

Table 4.12. Number of EV charging stations in parking lots according to 2040 scenario.

Parking lots	Number of EV Stations	Transformer to be connected to
Rectorate	11	TR1-B
FEAS	6	TR3
Student Affairs (Across the Mosque)	16	TR3
Faculty of Theology	6	TR4
Faculty of Engineering	11	TR6
Stadium	6	TR7

According to this table, 242 kW (30.25%) load is added to TR1-B, 484 kW (48.4%) to TR3, 132 kW (13.2%) to TR4, 242 kW (30.25%) to TR6 and 132 kW (13.2%) load is added to TR7. The values have been given in Table 4.13 as follows.

Table 4.13. The additional load of EV Charging Stations according to the 2040 scenario.

Parking lots	EV load (kW)	Transformer to be connected to
Rectorate	242	TR1-B
FEAS	132	TR3
Student Affairs (Across the Mosque)	352	TR3
Faculty of Theology	132	TR4
Faculty of Engineering	242	TR6
Stadium	132	TR7

Referring to the data in the graphs and tables given in Chapter 4.1, 4.2 and 4.3, the additional load that the EV charging stations will bring to the transformers according to the 2040 scenario is at a level that can be met by the transformers. Considering the general increase in electrical loads until 2040, it is estimated that the transformers will be loaded around 70-75% max.

ETAP single line diagram of 2040 scenario has been shown in Figure 4.32.

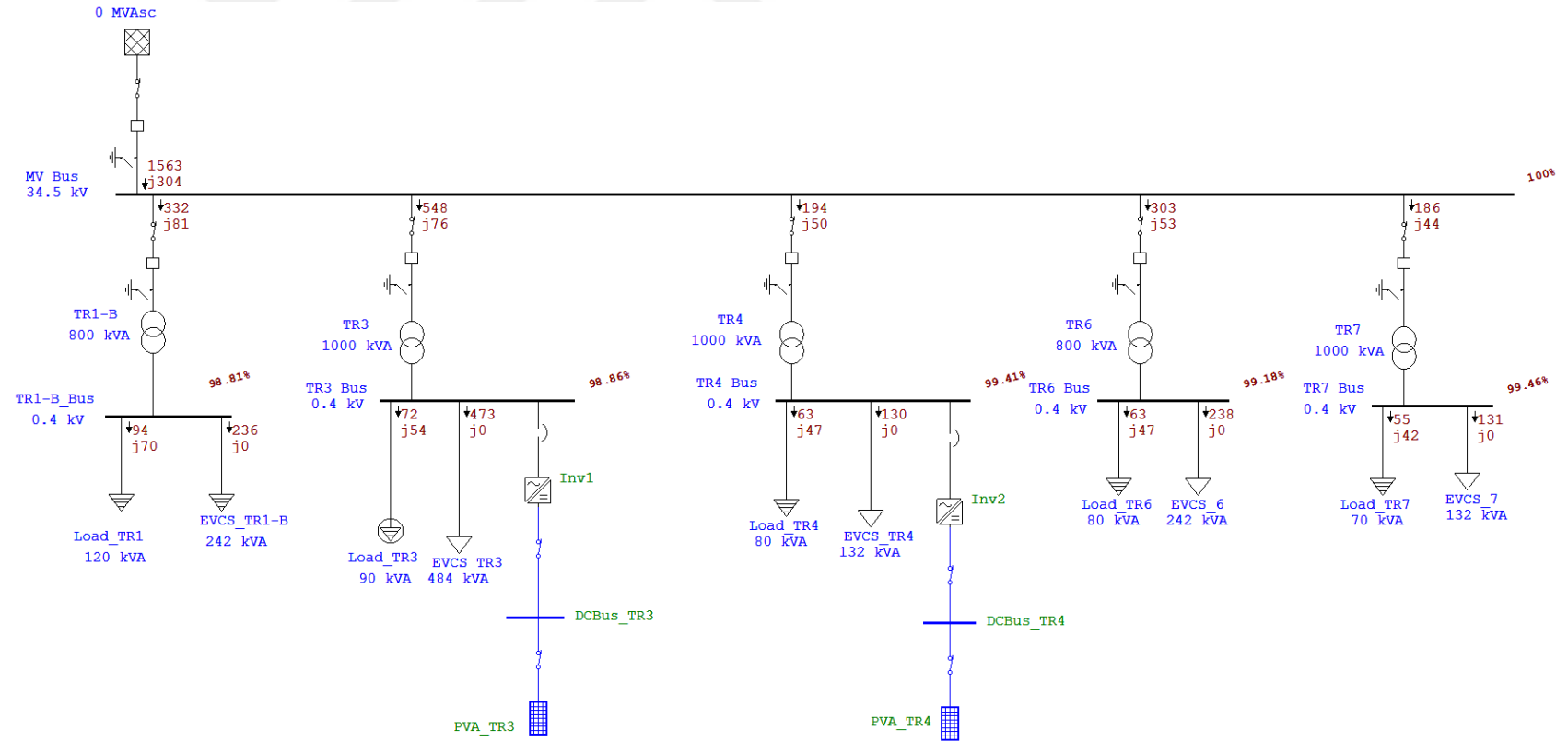

Figure 4.32. ETAP single line diagram of 2040 scenario.

CHAPTER 5

CONCLUSION AND SUGGESTIONS

In this thesis, the effects of electric vehicles on the electricity grid have been evaluated. This evaluation is based on the parameters of the TOGG brand electrical vehicle for the distribution network of Karabük University Demir Çelik campus. Within the scope of this study, simulations and analyzes were made using ETAP Electrical Power System Analysis software in order to examine the effects of electric vehicle charging systems on the distribution network.

An analysis of the medium voltage (MV) and low voltage (LV) electricity networks of the Demir Çelik campus was conducted. Then, three different scenarios were studied for the years 2025, 2030 and 2040. The probable number of EVs and the number of EV charging stations in the Demir Çelik campus in 2025, 2030 and 2040 were estimated and based on these numbers; the load rates of the transformers were predicted.

According to the 2025 scenario, there will be 343 EVs and 10 EV charging stations. Based on the scenario, a load of 44 kW (5.5%) will be added to TR1-B, 88 kW (8.8%) to TR3, 22 kW (2.2%) to TR4, 44 kW to TR6 (5.5%) and 22 kW (2.2%) load will be added to TR7.

In the 2030 scenario, there will be 785 EVs and 20 EV Charging Stations. Based on the scenario, a load of 88 kW (11%) will be added to TR1-B, 176 kW (17.6%) to TR3, 44 kW (4.4%) to TR4, 88 kW (11%) to TR6 and 44 kW (4.4%) load will be added to TR7.

In the 2040 scenario, there will be 2100 EVs and 56 EV Charging Stations. According to it, 242 kW (30.25%) load will be added to TR1-B, 484 kW (48.4%) to TR3, 132

kW (13.2%) to TR4, 242 kW (30.25%) to TR6 and 132 kW (13.2%) load will be added to TR7.

It is possible that EV charging stations will adversely affect transformers in terms of their loading rates in 2025 and 2030, considering the power of the transformers and other electrical loads in respective years. It is expected that the transformers will be loaded at a maximum of 10-15% in 2025, and a maximum of 15-25% in 2030. In 2040, the transformers are estimated to be loaded at a maximum of 70-75%.

While selecting the transformers to which the charging stations will be connected, the proximity to the parking areas as well as the loading conditions of the transformers were taken into account. As mentioned before, the Student Affairs Parking Lot is the biggest lot and is suitable to be connected to both TR3 and TR4. However, it was preferred to be connected to TR3 because there is 300 KW SES (solar energy system) in the region fed by TR3.

The possibilities of installation of new SES on the Demir Çelik campus were not evaluated in the scenarios. If new SES is installed, the load rates of the transformers will further decrease.

One of the effects of EVs on the grid is harmonics. The tested vehicle harmonic data in the investigated studies were used as data within the scope of the thesis, and it was observed that the harmonic levels produced by the vehicles in general were within the limits specified in the standards published by IEEE and IEC. In the simulations and analyzes carried out in the studies, some vehicles were calculated to add harmonics to the grid at 5%-12% THD values, which are considerably above the limits. Although it has been observed in similar studies on different versions of vehicle charging stations that they can be operated at 32A and 16A, vehicles can produce harmonic values that exceed the limits. It has been stated that vehicles can be used without any harmonic problems if appropriate equipment and charging type are used at the appropriate level for the vehicle.

In this study, only the distribution network of Karabük University Demir Çelik campus was studied. There are studies and reports prepared throughout the city and the country, albeit in a small number. According to these studies, Turkey seems to be ready for a larger extent of EV charging station integration into the grid in the short and medium term. However, there are also reports showing that new investments are needed to increase the capacity and quality of the electricity grid in some cities and regions.

Turkey's local and national electric vehicle, TOGG EV will be a source of motivation for private and public investments in the way of making new investments on such grounds. Therefore, Turkey is not expected to face any serious problems in the integration of EVs into electricity and distribution networks.

With the spread of EVs in the up-coming years, it will be possible to access more data, to make more concrete analyzes and to evaluate the results.

REFERENCES

1. Internet: <https://www.iea.org/data-and-statistics/charts/global-energy-related-co2-emissions-by-sector>
2. Internet: <https://www.iea.org/reports/global-ev-outlook-2021>
3. Internet: <https://www.iea.org/data-and-statistics/charts/electric-vehicle-stock-in-the-ev3030-scenario-2018-2030>.
4. Internet: <https://www.shura.org.tr/wp-content/uploads/2019/12/Turkiye-ulastrima-sektorunun-donusumu-Elektrikli-araclar%C4%B1n-Turkiye-dagitim-sebekesine-etkileri-.pdf>
5. L. I. Dulao, D. Bica, Effects of Electric Vehicles on Power Networks, *13th International Conference Interdisciplinarity in Engineering (INTER-ENG 2019), Procedia Manufacturing* 46: 370–377,(2020).
6. A. M. Hariri, H. H. Dezaki, M. A. Hejazi, A novel generalized analytical reliability assessment method of smart grids including renewable and non-renewable distributed generations and plug-in hybrid electric vehicles, *Reliability Engineering and System Safety* 196 (2020).
7. M. R. Khalid, M. S. Alam, A. Sarwar, J. Asghar, A Comprehensive review on electric vehicles charging infrastructures and their impacts on power-quality of the utility grid. *eTransportation* 1, 100006 (2019).
8. I. Sami, Z. Ullah, K. Salman, I. Hussain, S. M. Ali, B. Khan, C. A. Mehmood, U. Farid, A Bidirectional Interactive Electric Vehicles Operation Modes: Vehicle-to-Grid (V2G) and Grid-to-Vehicle (G2V) Variations within Smart Grid, *2019 International Conference on Engineering and Emerging Technologies (ICEET)*, IEEE 10.1109/CEET1.8711822(.2019).
9. Q. Cui, X. Bai, S. Zhu, and B. Huang, “Cost-benefit calculation and analysis of v2g system,” in *2016 China International Conference on Electricity Distribution (CICED)*. IEEE,1–5(2016).

10. W. Zhang, K. Spence, R. Shao, and L. Chang, "Optimal scheduling of spinning reserve and user cost in vehicle-to-grid (v2g) systems," *in 2018 IEEE Energy Conversion Congress and Exposition (ECCE)*. *IEEE*, 1058–1064 (2018).
11. M. S. Ahmad and S. Sivasubramani, "Multi-objective v2g energy storage system for grid support with cost and emission reduction," *in 2016 IEEE Region 10 Conference (TENCON)*. *IEEE*,. 1925–1928(2016).
12. Z. Luo, Z. Hu, Y. Song, Z. Xu, H. Liu, L. Jia, and H. Lu, "Economic analyses of plug-in electric vehicle battery providing ancillary services," *in 2012 IEEE International Electric Vehicle Conference*. *IEEE*, 1–5(2012).
13. M. Kumar, V. Gupta, R. Kumar, and B. Panigrahi, "Customer oriented electric vehicle charging scheduling in day-ahead market via aggregative game model," *in 2018 8th IEEE India International Conference on Power Electronics (IICPE)*. *IEEE*,1–6 (2018).
14. T. H. Mohamed and A.-m. M. Abdel-Rahim, "Single area power system voltage and frequency control using v2g scheme," *in 2017 Nineteenth International Middle East Power Systems Conference (MEPCON)*. *IEEE*, 971–975 (2017).
15. N. Zou, L. Qian, and H. Li, "Auxiliary frequency and voltage regulation in microgrid via intelligent electric vehicle charging," *in 2014 IEEE International Conference on Smart Grid Communications (SmartGrid-Comm)*. *IEEE*, 662–667 (2014).
16. O. Kolawole and I. Al-Anbagi, "Optimizing electric vehicles charging cost for frequency regulation support in a smart grid," *in 2017 IEEE Electrical Power and Energy Conference (EPEC)*. *IEEE*,1–6 (2017).
17. C. Li, L. Zeng, B. Zhou, X. Liu, Q. Wu, D. Zhang, and S. Huang, "An optimal coordinated method for evs participating in frequency regulation under different power system operation states," *Ieee Access*,(6): 62 756–62 765, (2018).
18. Zheng, Y., Shang, Y., Shao, Z., & Jian, L.. A novel real-time scheduling strategy with near-linear complexity for integrating large-scale electric vehicles into smart grid. *Applied Energy*, 217: 1–13 (2018).
19. [15] Liu, L., Kong, F., Liu, X., Peng, Y., & Wang, Q. A review on electric vehicles interacting with renewable energy in smart grid. *Renewable and Sustainable Energy Reviews*, 51: 648–661, (2015).
20. Shokrzadeh, S., Ribberink, H., Rishmawi, I., & Entchev, E. *A simplified control algorithm for utilities to utilize plug-in electric vehicles to reduce distribution transformer overloading*. *Energy*, 133: 1121–1131, (2017).

21. Park, C. A Study of Smart Grid Effects on Electric Vehicle Management Considering the Change of the Power Capacity Mix. *The Open Transportation Journal*, 12(1), 215–229,(2018).
22. S. Bahrami, and M. Parniani, "Game theoretic based charging strategy for plug-in hybrid electric vehicles", *IEEE Trans. Smart Grid*, 5: 2368-2375, (2014).
23. T. Gnann, A. Klingler, and M. Kühnbach, "The load shift potential of plug-in electric vehicles with different amounts of charging infrastructure", *J. Power Sources*, 390: 20-22 (2018).
24. J. García-Álvarez, I. González-Rodríguez, C.R. Velaa, and M.A. González, "Genetic fuzzy schedules for charging electric vehicles", *Comput. Ind. Eng.*,121: 51-61, (2018).
25. A. Mohammadi, and S. Rabinia, A comprehensive study of Game Theory applications for smart grids, demand side management programs, and transportation networks. *arXiv*:1804.10712 (2019).
26. H. Amini, M.P. Moghaddam, and O. Karabasoglu, "Simultaneous allocation of electric vehicles' parking lots and distributed renewable resources in smart power distribution networks", *Sustainable Cities and Society*,28: 332-342, (2017).
27. M.A. Lopez, S. Torre, S. Martin, and J.A. Aguado, "Demand-side management in smart grid operation considering electric vehicles load shifting and vehicle-to-grid support", *Elec Power Energy Syst*, 64:689-698, (2015).
28. J.D. Kim, and M. Rahimi, "Future energy loads for a large-scale adoption of electric vehicles in the city of Los Angeles: Impacts on greenhouse gas (GHG) emissions", *Energy Policy*, vol. 73, pp. 620-630, 2014.
29. A. Weis, P. Jaramillo, and J. Michalek, "Estimating the potential of controlled plug-in hybrid electric vehicle charging to reduce operational and capacity expansion costs for electric power systems with high wind penetration", *Appl. Energy*,115: 190-204 (2014).
30. J. Delgado, R. Faria, P. Moura, and A.T. de Almeida, "Impacts of plug-in electric vehicles in the portuguese electrical grid", *Transp. Res. Part D Transp. Environ.*,62: 372-385 (2018).
31. M. Sorrentino, G. Rizzo, and L. Sorrentino, "A Study aimed at assessing the potential impact of vehicle electrification on grid infrastructure and road-traffic green house emissions", *Appl. Energy*,120: 31-40, (2014).
32. E.F. Choma, and C.M. Ugaya, "Environmental impact assessment of increasing electric vehicles in the Brazilian fleet", *J. Clean. Prod*,152 497-507, (2017).

33. C. Croziera, D. Apostolopouloub, and M. McCullocha, "Mitigating the impact of personal vehicle electrification: A power generation perspective", *Energy Policy*, 118: 474-481 (2018).
34. Shaukat, N., Khan, B., Ali, S., Mehmood, C., Khan, J., Farid, U., Majid, M., Anwar, S., Jawad, M., & Ullah, Z. A survey on electric vehicle transportation within smart grid system. *Renewable and Sustainable Energy Reviews*, 81: 1329–1349, (2018).
35. Rahbari, O., Vafaeipour, M., Omar, N., Rosen, M. A., Hegazy, O., Timmermans, J. M., Heibati, S., & Bossche, P. V. D. *An optimal versatile control approach for plug-in electric vehicles to integrate renewable energy sources and smart grids. Energy*, 134, 1053–1067 ((2017).
36. Shaaban MF, Atwa YM, El-Saadany EF. DG allocation for benefit maximization in distribution networks. *IEEE Trans Power Syst*, 28:639-349 (2013).
37. Ferruzzi G, Graditi G, Rossi F, Russo A. Optimal operation of a residential microgrid: the role of demand side management. *Intell Ind Syst*; 1:61-82 (2015).
38. Vasirani M, Kota R, Cavalcante RL, Ossowski S, Jennings NR. An agent-based approach to virtual power plants of wind power generators and electric vehicles. *IEEE Trans Smart Grid*;4: 1314-1322 (2013).
39. Falvo MC, Graditi G, Siano P. Electric vehicles integration in demand response programs. In: International symposium on Power electronics, electrical drives, *automation and motion (SPEEDAM)*, *IEEE*; 548-553 (2014).
40. Lopez M, De La Torre S, Martín S, Aguado J. Demand-side management in smart grid operation considering electric vehicles load shifting and vehicle-to-grid support. *Int J Electr Power & Energy Syst*; 64:689-698 (2015).
41. Graditi G, Ippolito M, Telaretti E, Zizzo G. Technical and economical assessment of distributed electrochemical storages for load shifting applications: an Italian case study. *Renew Sustain Energy Rev*;57: 515-523 (2016).
42. Rahimi-Eichi H, Ojha U, Baronti F, Chow M-Y. Battery management system: an overview of its application in the smart grid and electric vehicles. *IEEE Ind Electron Mag*;7: 4 -16 (2013).
43. Di Silvestre ML, Sanseverino ER, Zizzo G, Graditi G. An optimization approach for efficient management of EV parking lots with batteries recharging facilities. *J Ambient Intell Humaniz Comput*;4: 641 - 649 (2013).

44. Tie SF, Tan CW. A review of energy sources and energy management system in electric vehicles. *Renew Sustain Energy Rev*; 20: 82 -102 (2013).
45. Omar N, Daowd M, Bossche PVD, Hegazy O, Smekens J, Coosemans T, et al. Rechargeable energy storage systems for plug-in hybrid electric vehicles assessment of electrical characteristics. *Energies*;5: 2952 - 2988 (2012).
46. Omar N, Monem MA, Firouz Y, Salminen J, Smekens J, Hegazy O, et al. Lithium iron phosphate based battery e assessment of the aging parameters and development of cycle life model. *Appl Energy*; 113:1575 - 1585 (2014).
47. Kim, E. L., Tabors, R. D., Stoddard, R. B., & Allmendinger, T. E. Carbitrage: Utility Integration of Electric Vehicles and the Smart Grid. *The Electricity Journal*, 25(2), 16–23, (2012).
48. Das, S., Acharjee, P., & Bhattacharya, A. (2021). Charging Scheduling of Electric Vehicle Incorporating Grid-to-Vehicle and Vehicle-to-Grid Technology Considering in Smart Grid. *IEEE Transactions on Industry Applications*, 57(2), 1688–1702, (2021).
49. Salehpour, M. J., & Tafreshi, S. M. (2020). Contract-based utilization of plug-in electric vehicle batteries for day-ahead optimal operation of a smart micro-grid. *Journal of Energy Storage*, 27, 101 - 157, (2020).
50. Flah, A, Lassaad, S, Mahmoudi, C,. “Overview of Electric Vehicle Concept and Power Management Strategies”, *ResearchGate*, **DOI: 10.1109/CISTEM..7077026** (2014).
51. Racz, A, Muntean, I, Stan, S,. “ A Look into electric / hybrid cars from and ecological perspective”, *Science Direct, Procedia Technology* 19: 438-443 (2015).
52. Noor, F, Padmanaban, S, Popa, L , Mollah M, and Hossain E, “A Comprehensive Study of Key Electric Vehicle (EV) Components, Technologies, Challenges, Impacts, *and Future Direction of Development” (S.P); (E.H).*(2017).
53. Andwari, A, Pesiridis, A, Rajoo, S, Botas, R, Esfahanian, V, “A review of Battery Electric Vehicle technology and readiness levels”, ScienceDirect, *Jornal homepage, Renewable and sustainable Energy Reviews* 78 , 4141-430, <http://dx.doi.org/10.1016/j.rser.2017.03.138>. (2017)
54. Temiz, A. Assessment of Impacts of Electric Vehicles on Low Voltage Distribution Network in Turkey. Master of Science Thesis, Middle East Technical University, *Ankara, Turkey*,. 8-9 (2015).
55. Özcan, M. E. Integration of electric vehicles into the distribution network. Master of Science Thesis, Marmara University, İstanbul, Turkey (2015),

56. Internet: <https://www.omazaki.co.id/en/types-of-electric-cars-and-working-principles/>
57. Stricklett, K, “Advanced Components for Electric and Hybrid Electric Vehicles”, NIST Special Publication, *National Institute of Standards and Technology*, 860, 27-28 (1993).
58. Lebkowski, A, “ Management System for Electric Vehicle Battery Pack”, *ResearchGate*, *Przegląd Elektrotechniczny* 93 (9) : 46 - 53, DOI: [10.15199/48.09.09](https://doi.org/10.15199/48.09.09), (2017).
59. Internet: “Immersion of Electric Vehicle Batteries: IDTechEx Discusses the Best Way to Keep Cool”, CISION PR NEWSWIRE, <https://www.prnewswire.co.uk>, (2020)
60. Hughes, A, . “ Electric Motors and drives fundamentals, types and applications, Third Edition”, s. Published by Elsevier Ltd, *ISBN-10:0-7506-4718-3*,(2006).
61. Roukas, M., Soulier, N., “ Development of the control system for an electric vehicle”, Master thesis, *Chalmers University of Technology*, (2013)
62. Klass, V., “ Battery health estimation in electric vehicles”, , *ISBN 978-91-7595-671-8* (2015).
63. Sharma, S., Panwar, A., Tripathai, M., “ Storage technologies for electric vehicles, *Journal of Traffic and transportation engineering* , 340-361, (2020). <https://doi.org/10.1016/j.jtte.2020.04.004>
64. Hayes, A., “New Battery Technology Investment Opportunities”, *Investopedia*, (2019).
65. Young, K., Wang, C., Strunz, K., “ Electric Vehicle Battery technologies”, *Semantic Scholar*, (2012).
66. Internet:http://tehad.org/wpcontent/uploads/2020/11/%C5%9Earj_%C4%B0stasyonu_Terminoloji_ve_Gruplama_FINAL_DRAFT.pdf
67. Carter,R, *Impacts of Harmonic Distortion from Charging Electric Vehicles on Low Voltage Networks, EVS26 Los Angeles, California*, (2012).
68. Dubey,A., Electric Vehicle Charging on Residential Distribution Systems: **Impacts and Mitigations**, **Digital Object Identifier 10.1109/ACCESS.2015.2476996** (2015)
69. Internet: <https://www.togg.com.tr/content/otomobil>
70. Internet: <https://zes.net/yerli-otomobil-togg.html>

71. Internet: <https://gersan.com.tr/page/elektrikli-arac-sarj-istasyonu/>



RESUME

Wesam Anis Mohamed Elmasudi completed his primary and secondary education in Msallata-Libya. He continued his undergraduate studies at the Higher Institute of Comprehensive Professions, Msalata - Department of Control in 2006. In 2011, he joined the General Electricity Company - Libya. As of 2018, he is pursuing a master's degree at Karabuk University.

